

State of New Jersey
Department of Environmental Protection
Division of Water Resources



Ocean County Demonstration Study
**Stormwater Management Facilities
Maintenance Manual**

June 1989

New Jersey State Library

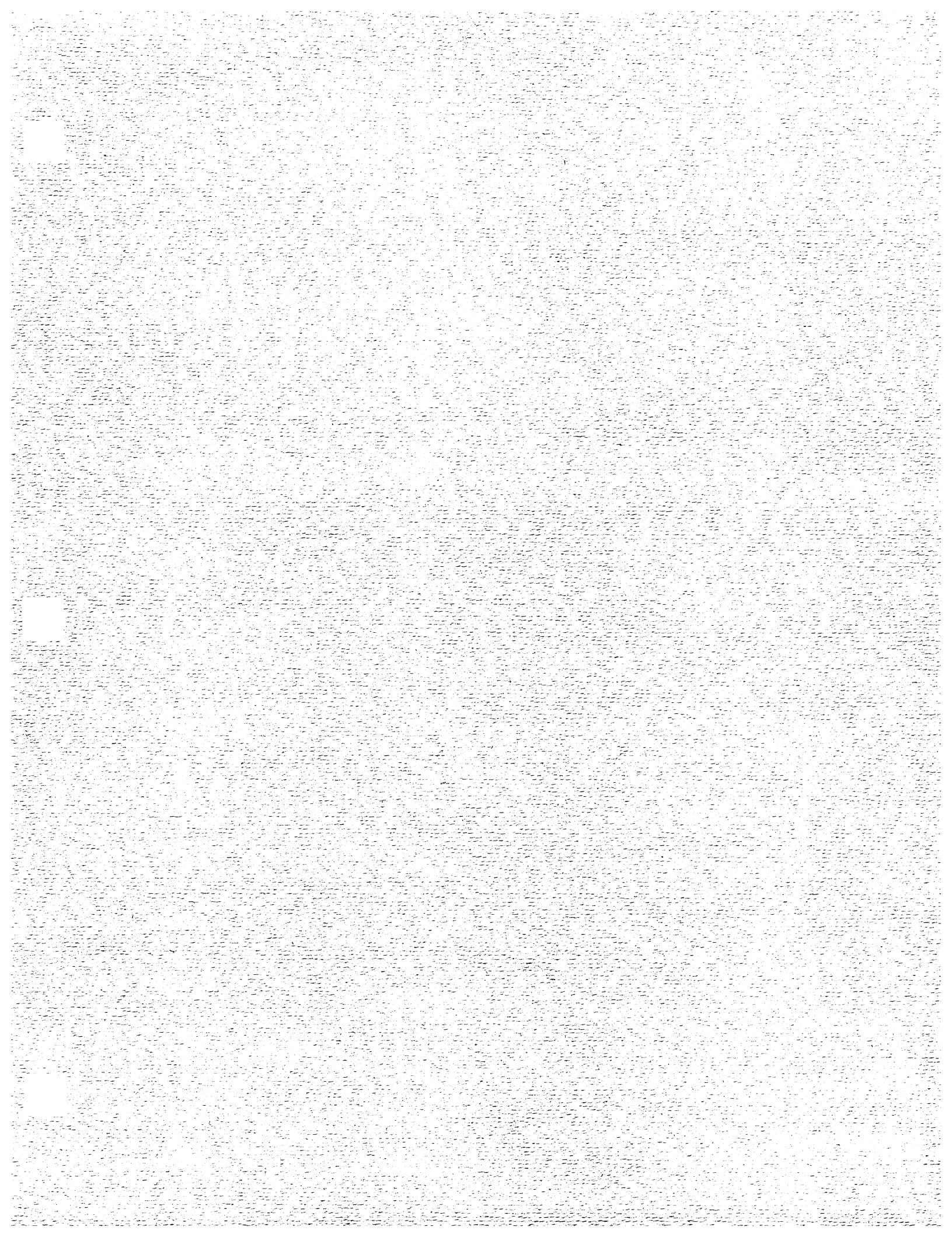

State of New Jersey
Department of Environmental Protection
Division of Water Resources

Ocean County Demonstration Study
Stormwater Management Facilities
Maintenance Manual

Prepared by:

Ocean County Planning & Engineering Departments

Assisted by:

Killam Associates

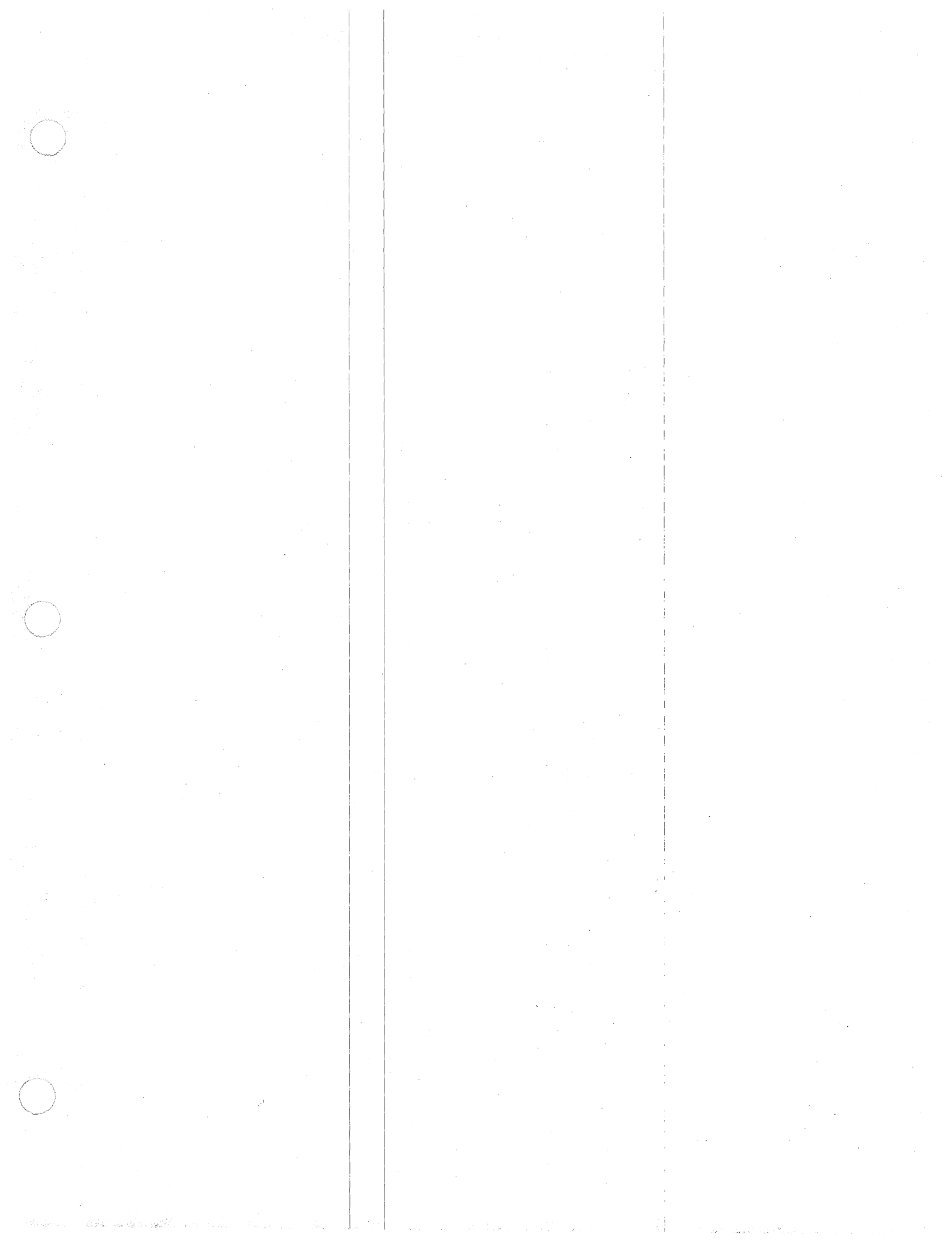

ACKNOWLEDGEMENTS

This Manual was developed by the County of Ocean and Killam Associates, Consulting Engineers, through a demonstration grant provided by the Division of Water Resources of the New Jersey Department of Environmental Protection.

The contributions of the following individuals are acknowledged: **Ms. Susan Burke**, NJDEP Project Manager; **Mr. Richard E. Lane, P.E.**, Ocean County Engineer; **Ms. Susan L. Ney**, Project Manager, Ocean County Planning Board; **Mr. Leo J. Coakley, P.E.**, Project Manager, Killam Associates; **Mr. Joseph J. Skupien, P.E.**, Project Engineer, Killam Associates; and **Mr. Carl W. Andreassen, P.E.**, Killam Associates.

Appreciation is extended to the many public officials and others who provided valuable insight and information during the Manual's development.

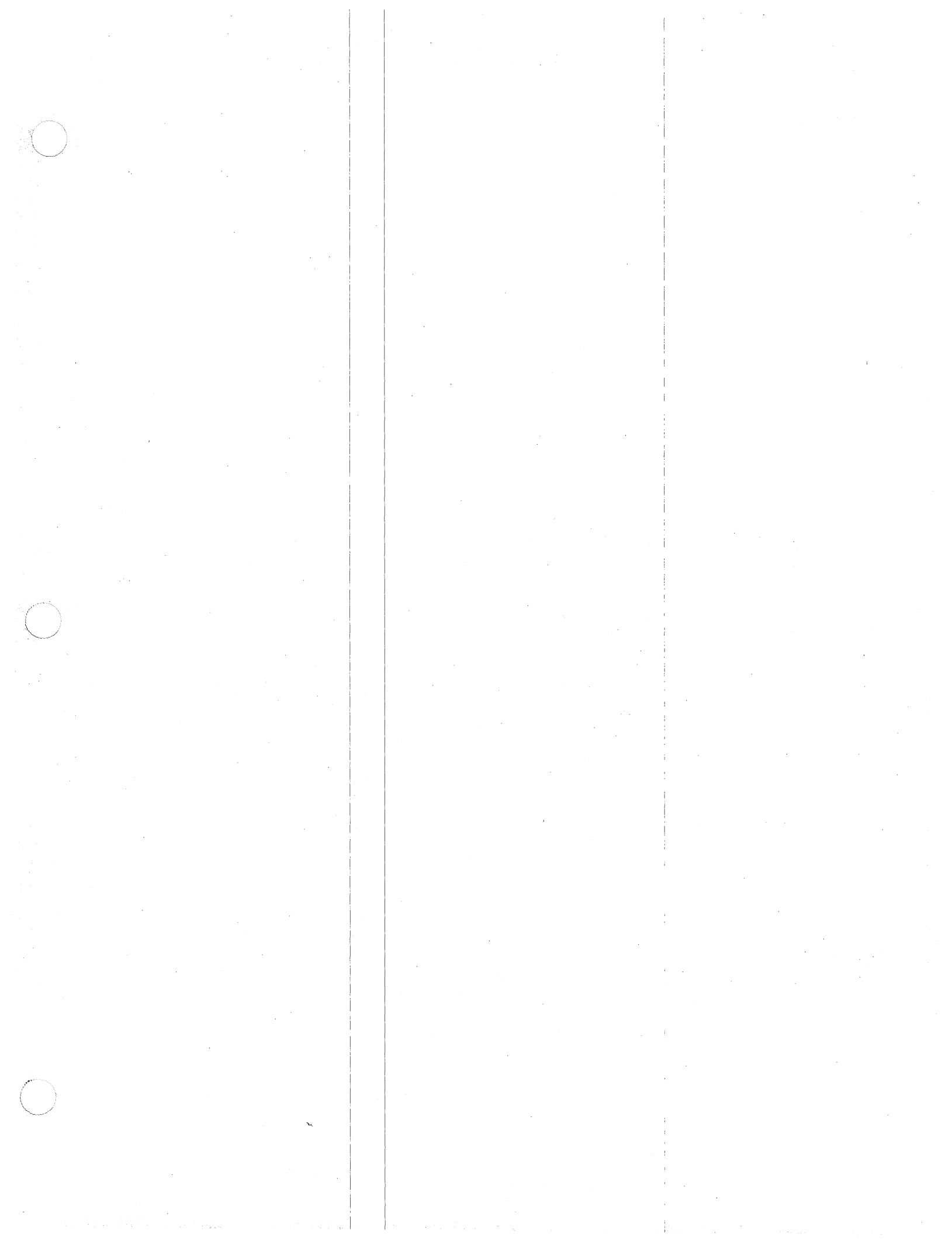

N.J. DEPARTMENT OF ENVIRONMENTAL PROTECTION
STORMWATER MANAGEMENT FACILITIES MAINTENANCE MANUAL

TABLE OF CONTENTS

PREFACE	P-1
INTRODUCTION	I-1
CHAPTER ONE	
OWNERSHIP AND MAINTENANCE RESPONSIBILITY	OWN-1
CHAPTER TWO	
PLANNING AND DESIGN GUIDELINES	PLAN-1
CHAPTER THREE	
CONSTRUCTION INSPECTION	INSPECT-1
CHAPTER FOUR	
MAINTENANCE EQUIPMENT AND PROCEDURES	MAINT-1
CHAPTER FIVE	
REGULATORY ASPECTS	REG-1
CHAPTER SIX	
COST DATA AND FINANCING TECHNIQUES	COST-1



STORMWATER MANAGEMENT FACILITIES MAINTENANCE MANUAL

PREFACE

The New Jersey Water Supply Bond Act of 1981 authorized the funding for State and local water supply and watershed management projects. The 1982 New Jersey Water Supply Master Plan responded to this authorization by identifying the need for specific watershed management and aquifer protection projects to help implement the goals of the Plan. In June 1983, Ocean County submitted a proposal in response to the New Jersey Department of Environmental Protection's (NJDEP) request for proposals for County level demonstration projects. In 1984, Ocean County was selected by the NJDEP to participate in the Demonstration Project on the Long Term Maintenance of Stormwater Management Facilities. The project organization included retaining an engineering consultant. Killam Associates, of Millburn, New Jersey submitted a proposal to the NJDEP and was subsequently awarded the project.

The purpose of the Demonstration Project was to address the increasing problem of the lack of maintenance procedures undertaken for stormwater management facilities (SWMFs). The result of insufficient maintenance procedures at SWMFs has been poor water quality and flood control as well as an increased threat to public health and safety. The objective for the project has been to develop a **STORMWATER MANAGEMENT FACILITY MAINTENANCE MANUAL**. The **MANUAL** responds to maintenance problems by addressing six areas relative to the overall management of SWMFs. These six areas are: Ownership and Maintenance Responsibility, Planning and Design Guidelines, Construction Inspection, Maintenance Equipment and Procedures, Regulatory Aspects, and Cost Data and Financing Techniques.

The Demonstration Project team consisted of representatives from the NJDEP, the Ocean County Planning and Engineering Departments, and Killam Associates. The following is a brief summary of the project tasks undertaken in developing the recommendations contained in the **MAINTENANCE MANUAL**.

TASK: Onsite Field Evaluations of 51 SWMF Sites in six New Jersey counties. The facility types included detention, retention, infiltration, and regional basins.

PURPOSE: To determine whether design, construction, and/or maintenance procedures were the basis for maintenance problems at SWMFs.

STORMWATER MANAGEMENT FACILITIES MAINTENANCE MANUAL

TASK: Stormwater Management Questionnaire on the Design, Construction, and Maintenance of SWMFs. The Questionnaire was sent to private engineers and public agencies throughout New Jersey. A 21 percent response rate was achieved.

PURPOSE: To gather data on which calculation methods and design standards are most commonly used, how facilities are constructed, if SWMFs have secondary uses during project construction (such as sediment basins), and if a responsible party/agency for the maintenance of SWMFs is typically designated.

TASK: Agency Survey on Maintenance Problems. The Survey was sent to agencies which are either directly responsible for SWMF maintenance or are conducting maintenance procedures through facility owner default. A 35 percent response rate was achieved.

PURPOSE: To gather data on the types of maintenance procedures performed, schedules of maintenance programs, man-hours required to perform maintenance tasks, equipment utilized, and maintenance budget requirements.

TASK: Inventory of Stormwater Regulations.

PURPOSE: To determine current local, county, regional, and state stormwater management standards and the extent of maintenance requirements.

TASK: Draft Maintenance Manual Workshop Meetings.

PURPOSE: To meet with representatives of engineering firms, municipal and county engineering departments, Soil Conservation Districts, Mosquito Commissions, and Public Works Departments to present, discuss, and receive comments on the draft sections of the **MAINTENANCE MANUAL**.

The **MANUAL** is intended for use as a reference guide in the design of "minimum maintenance" SWMFs and the implementation of effective and comprehensive maintenance programs. It is designed to be applicable to the entire State, which includes a variety of geologic conditions. Therefore, the recommended guidelines in the **MANUAL** should be evaluated for their applicability to specific site conditions before being utilized. The recommendations regarding the design and construction of SWMFs are intended to address the management needs of both existing and new facilities.

**NEW JERSEY
DEPARTMENT OF ENVIRONMENTAL PROTECTION
STORMWATER MANAGEMENT FACILITIES
MAINTENANCE MANUAL**

INTRODUCTION

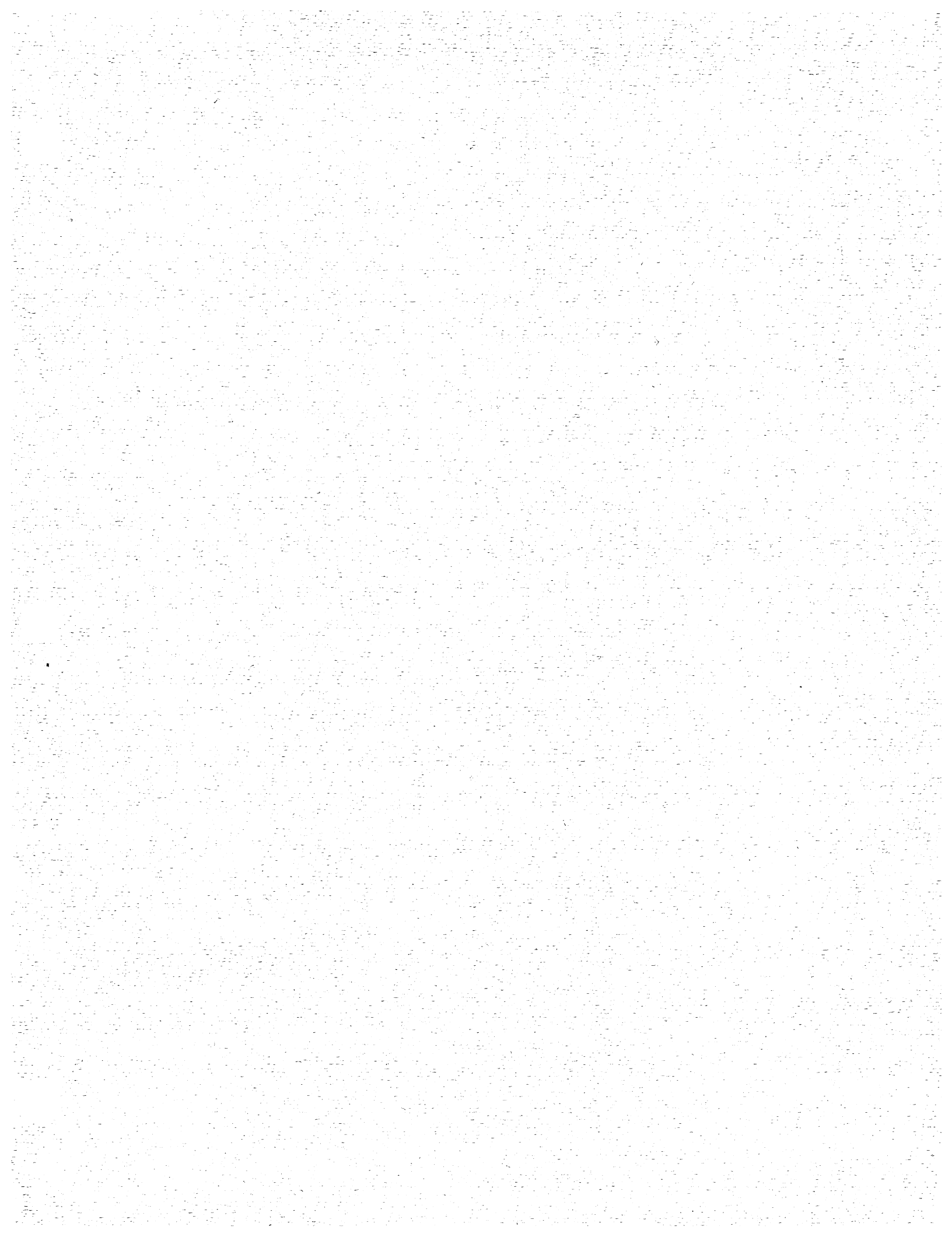

STORMWATER MANAGEMENT FACILITIES MAINTENANCE MANUAL

INTRODUCTION

Throughout New Jersey, Stormwater Management Facilities (SWMFs) have become standard components of land development projects and familiar sights in our modern landscape. Although their features and characteristics may vary, all SWMFs share a common goal: To mitigate the adverse hydrologic impacts of land development and protect downstream areas from flooding, erosion, and/or water quality degradation. To achieve this goal, all SWMFs share a common need: Thorough maintenance performed on a regular basis. The objective of the **STORMWATER MANAGEMENT FACILITIES MAINTENANCE MANUAL** is to insure that this maintenance is provided. The **MANUAL** pursues this objective in several ways:

- * By highlighting the important role that SWMFs have come to play in managing the State's stormwater resources.
- * By demonstrating the need for regular and thorough SWMF maintenance.
- * By presenting detailed information regarding such maintenance, not only during a SWMF's operating life, but during its planning, design, and construction phases.
- * By describing methods of securing adequate financing of SWMF maintenance programs.

The **MAINTENANCE MANUAL** is divided into six Chapters, each of which answers an important question regarding SWMF maintenance:

* **CHAPTER ONE** addresses the question of **WHO IS RESPONSIBLE?** for SWMF maintenance. It includes descriptions of various SWMF owners and a variety of possible maintenance responsibility arrangements. It provides ways of evaluating a SWMF owner's maintenance capabilities, as well as advice on how to maintain a SWMF which has been "abandoned" by its owner. Throughout the Section, strong emphasis is placed on the need to designate a single person or entity as having the ultimate responsibility for a SWMF's maintenance and who will ultimately bear the blame if such maintenance is neglected.

* **CHAPTERS TWO, THREE, and FOUR** provide several answers to the question **WHAT HAS TO BE DONE?** **CHAPTER TWO** presents detailed guidelines for planning and designing a SWMF that requires the least amount of maintenance effort and expense. It also includes descriptions of the

STORMWATER MANAGEMENT FACILITIES MAINTENANCE MANUAL

numerous SWMF maintenance problems that actually originate during the planning and design stages. **CHAPTER THREE** contains recommended measures to insure that a SWMF is constructed in accordance with its "least maintenance" design. **CHAPTER FOUR** describes the equipment and procedures necessary to undertake a comprehensive SWMF maintenance program. The primary theme of each of these Chapters is a familiar one: Preventative maintenance is far more effective and far less costly than corrective or remedial maintenance.

* **CHAPTER FIVE** presents answers to a very important question: **HOW TO GET IT DONE?** It highlights the key role that regulatory agencies can play in preventing and/or correcting SWMF maintenance neglect and recommends specific programs and procedures that these agencies can follow to insure that adequate SWMF maintenance levels are provided. Throughout the Chapter, the fundamental importance of SWMF maintenance to any successful municipal or county stormwater management program is emphasized.

* **CHAPTER SIX** addresses what may be the most important question of all: **HOW TO FINANCE IT?** It provides capital and operating expense data for those responsible for preparing SWMF maintenance budgets and advice on reducing overall SWMF maintenance costs. It also provides municipal and county governments with information regarding alternative methods of publicly financing SWMF maintenance. The Chapter's overall message is direct: The most important component of a successful SWMF maintenance program is adequate funding.

As can be seen from the above descriptions, the topic of SWMF maintenance is indeed a complex one and, as a result, the **STORMWATER MANAGEMENT FACILITIES MAINTENANCE MANUAL** will attract a variety of readers. To help these readers find what they're looking for, the first page of each Chapter contains a brief description of the Chapter's overall objectives and contents, as well as a list of intended readers. This should allow the reader to quickly assess the applicability of each Chapter to his or her specific interests or needs. In addition, major topics within each Chapter are presented under individual headings to further guide the reader. Each Chapter is written in a style suited to its intended readers. Finally, to further assist the reader, a summary of the major topics within each Chapter is presented in Table I-1.

The **STORMWATER MANAGEMENT FACILITIES MAINTENANCE MANUAL** was developed as part of the Ocean County Demonstration Project - Maintenance of Stormwater Management Facilities conducted jointly by the Ocean County Planning and Engineering Depart-

STORMWATER MANAGEMENT FACILITIES MAINTENANCE MANUAL

ments and the consulting engineering firm of Killam Associates, under a grant provided by the Division of Water Resources of the New Jersey Department of Environmental Protection. The **MANUAL** is the result of more than two years of research, study, and analysis of the pertinent aspects of SWMF maintenance and is based, in part, upon interviews and surveys of a wide variety of individuals and agencies in both the public and private sectors. As such, the **MANUAL** affords the reader a valuable opportunity to benefit from the experiences and advice of people involved in virtually every phase of SWMF maintenance.

Finally, additional information regarding the basis of the **STORMWATER MANAGEMENT FACILITIES MAINTENANCE MANUAL** can be found in the **Ocean County Demonstration Study Report** issued by the Department of Environmental Protection. This report includes an analysis of SWMF maintenance problems, results of field inspections, summaries of questionnaires and surveys, and an inventory of current SWMF maintenance regulations.

STORMWATER MANAGEMENT FACILITIES MAINTENANCE MANUAL

TABLE I-1

N.J. DEPARTMENT OF ENVIRONMENTAL PROTECTION
STORMWATER MANAGEMENT FACILITIES MAINTENANCE MANUAL

SUMMARY OF CONTENTS

CHAPTER ONE - OWNERSHIP AND MAINTENANCE RESPONSIBILITY

- * THE IMPORTANCE OF SWMF OWNERSHIP
- * OWNERSHIP-MAINTENANCE RESPONSIBILITY ARRANGEMENTS
- * EVALUATING PRIVATE OWNERS' MAINTENANCE CAPABILITY
- * DESIGNATION OF ORGANIZATIONAL RESPONSIBILITY
- * ADOPT A SYSTEM
- * MAINTAINING NON-OWNED FACILITIES
- * SUMMARY

CHAPTER TWO - PLANNING AND DESIGN GUIDELINES

- * DEFINITIONS
- * WHY WORRY ABOUT MAINTENANCE NOW?
- * GENERAL MAINTENANCE CONSIDERATIONS
- * WHO, WHAT, WHEN AND WHERE?
- * PLANNING AND DESIGN GUIDELINES

CHAPTER THREE - CONSTRUCTION INSPECTION

- * OVERVIEW
- * TYPICAL SWMF MAINTENANCE PROBLEMS THAT POOR CONSTRUCTION CAN CREATE
- * RECOMMENDED CONSTRUCTION INSPECTION PRACTICES

CHAPTER FOUR - MAINTENANCE EQUIPMENT AND PROCEDURES

- * THE IMPORTANCE OF SWMF MAINTENANCE
- * COMPREHENSIVE SWMF MAINTENANCE - AN OVERVIEW
- * SWMF MAINTENANCE PROCEDURES
- * MAINTENANCE EQUIPMENT AND MATERIALS
- * TABLES, CHECKLISTS, AND LOGS

TABLE I-1 (CONTINUED)

CHAPTER FIVE - REGULATORY ASPECTS

- * THE ROLE OF THE REGULATOR IN SWMF MAINTENANCE
- * SWMF REVIEW AND APPROVAL PROGRAMS
- * SWMF CONSTRUCTION INSPECTION PROGRAMS
- * SWMF MAINTENANCE INSPECTION PROGRAMS
- * PUBLIC ASSUMPTION OF SWMF MAINTENANCE
- * SAMPLE SWMF MAINTENANCE ORDINANCE

CHAPTER SIX - COST DATA AND FINANCING TECHNIQUES

- * OVERVIEW OF SWMF MAINTENANCE FINANCING
- * SWMF MAINTENANCE COSTS
- * PUBLIC FINANCING OF SWMF MAINTENANCE
- * SWMF MAINTENANCE COST SAVINGS

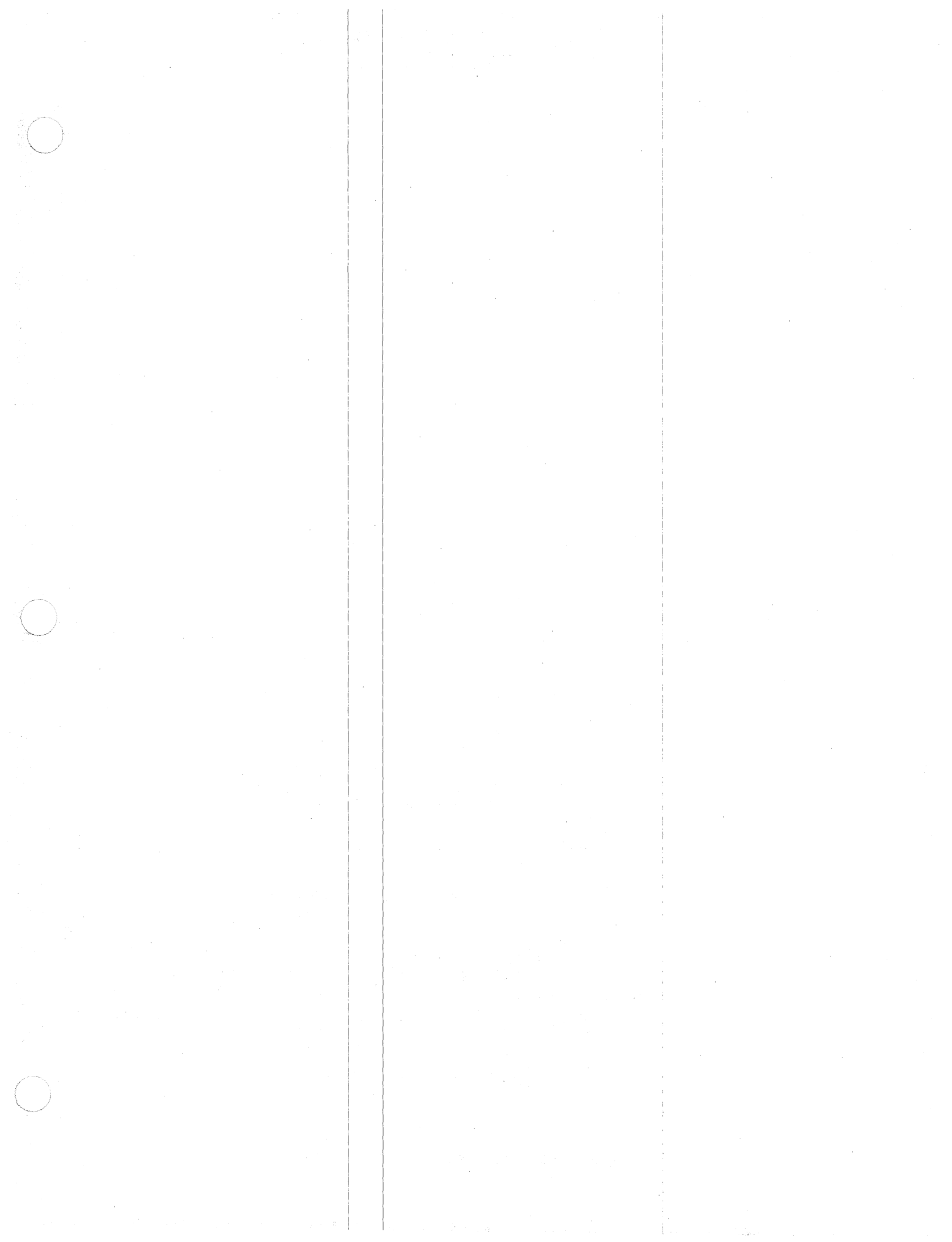

**NEW JERSEY
DEPARTMENT OF ENVIRONMENTAL PROTECTION
STORMWATER MANAGEMENT FACILITIES
MAINTENANCE MANUAL**

**CHAPTER ONE
OWNERSHIP AND MAINTENANCE RESPONSIBILITY**

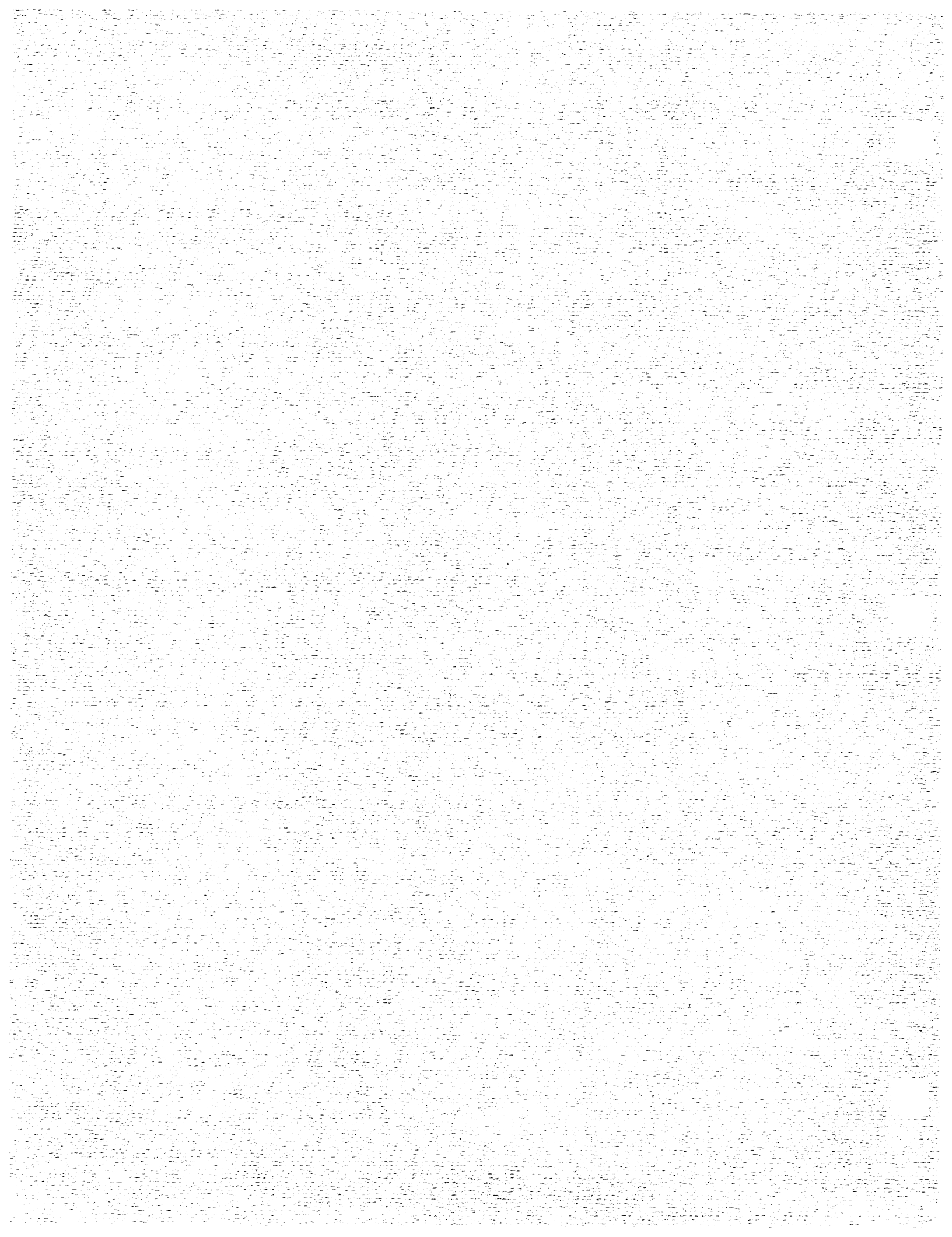

N.J. DEPARTMENT OF ENVIRONMENTAL PROTECTION
STORMWATER MANAGEMENT FACILITIES MAINTENANCE MANUAL
CHAPTER ONE - OWNERSHIP AND MAINTENANCE RESPONSIBILITY

TABLE OF CONTENTS

A. OBJECTIVES	OWN-1
B. INTENDED READERS	OWN-1
C. THE IMPORTANCE OF SWMF OWNERSHIP	OWN-1
D. OWNERSHIP-MAINTENANCE RESPONSIBILITY ARRANGEMENTS	OWN-3
E. EVALUATING PRIVATE OWNERS' MAINTENANCE CAPABILITIES	OWN-6
F. DESIGNATION OF ORGANIZATIONAL RESPONSIBILITY	OWN-8
G. ADOPT A SYSTEM	OWN-10
H. MAINTAINING NON-OWNED FACILITIES	OWN-11
I. SUMMARY	OWN-12

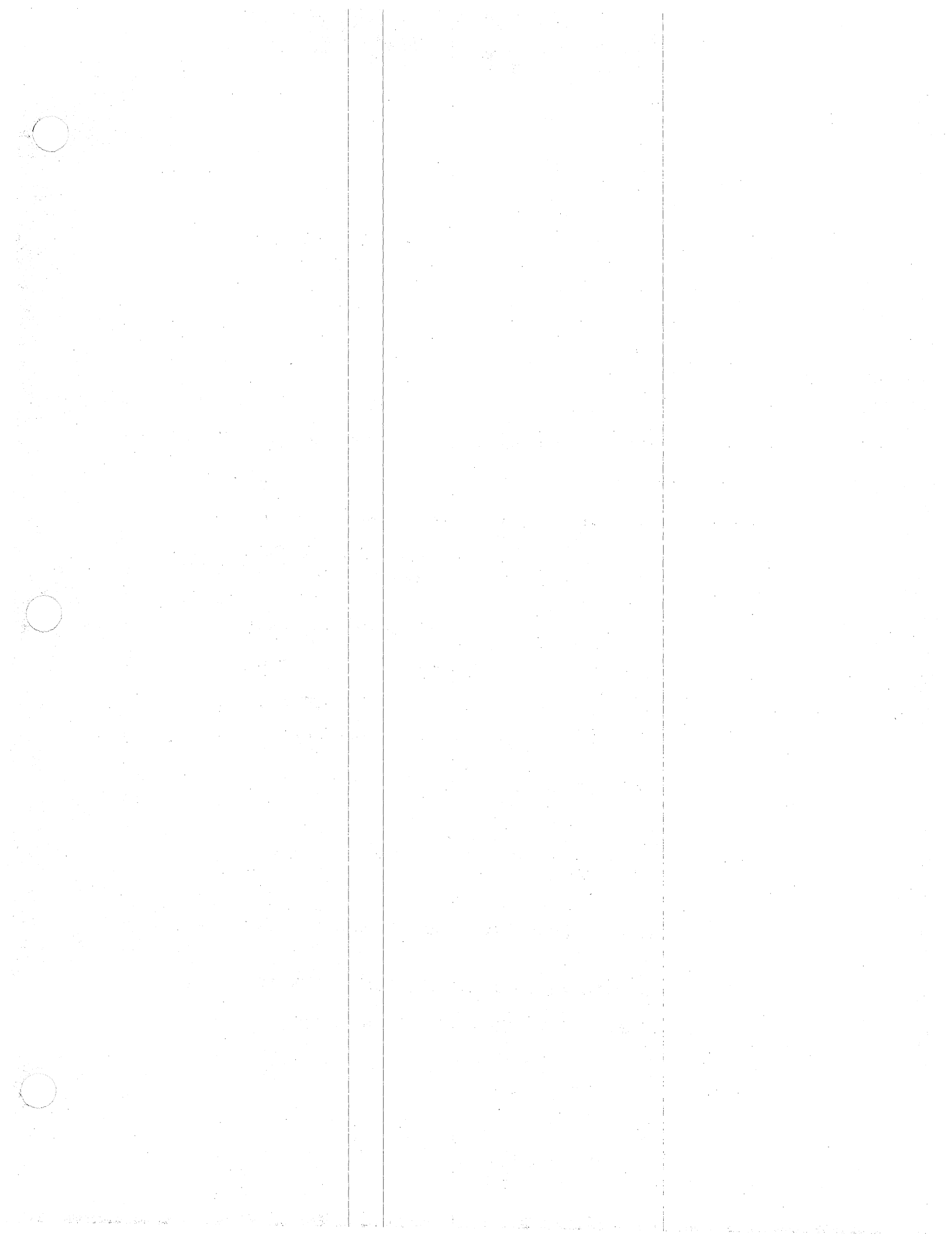

OWNERSHIP AND MAINTENANCE RESPONSIBILITY

A. OBJECTIVES

The owner of a Stormwater Management Facility (SWMF) is generally responsible for the maintenance of that facility. Very often, unfortunately, inadequate consideration is given during the design, review, and approval process to the owner's capabilities for conducting such maintenance. In addition, ownership of a SWMF may change during the facility's life. Unless the owner has adequate resources, facility maintenance may be neglected, resulting in a myriad of problems, including the eventual failure of the SWMF.

In light of the above, the objectives of this Section of the **STORMWATER MANAGEMENT FACILITIES MAINTENANCE MANUAL** are:

- * To present concepts which should be considered in establishing policies and regulations regarding, and linking, SWMF ownership and maintenance responsibility.
- * To develop a better understanding by the reader of the resources required to fulfill SWMF maintenance responsibilities.

B. INTENDED READERS

This Section of the **STORMWATER MANAGEMENT FACILITIES MAINTENANCE MANUAL** is intended primarily for:

- * **Public Officials and Regulatory Personnel**, who should find it helpful in establishing policy and regulations regarding appropriate designation of SWMF ownership.
- * **Facility Owners**, including potential future owners, who will find valuable information regarding the resources required for effective SWMF maintenance as well as factors to consider when evaluating their ability to fulfill designated maintenance responsibilities.

C. THE IMPORTANCE OF SWMF OWNERSHIP

The owner of a SWMF usually comes by that ownership as the result to some other course of action, rather than a direct desire for ownership of the SWMF itself. A public agency may acquire or construct a SWMF in order to alleviate a downstream flooding condition. A private individual or corporation may construct a SWMF as a matter of necessity in order to obtain municipal and/or county approval for a development and to mitigate the project's downstream runoff impacts.

OWNERSHIP AND MAINTENANCE RESPONSIBILITY

In some cases, a SWMF may be worked into a landscaping plan and become an attractive feature of the site, while in other cases, the facility is constructed in a portion of the site with low visibility to the owner and general public. Unfortunately, the adage "out of sight, out of mind" often applies. A SWMF is constructed for a purpose, and this purpose cannot be fully achieved without proper facility maintenance. In order to receive proper maintenance, the owner must be aware of the facility's purpose and need, and the absolute importance of proper maintenance. Failing that, the owner must be closely regulated by an agency which does.

Ultimately, it is the owner who is responsible for the proper planning, design, construction, and maintenance of a SWMF. The owner may undertake these actions either willingly or by requirement of a regulatory agency. Ideally, the owner will sense and fulfill these responsibilities even in the absence of any regulations. He should recognize that he may be held liable for consequences of his failure to meet these obligations. However, to insure proper maintenance of the facility, the owner must have the necessary institutional, managerial, and financial resources. Without the proper resources, the owner will not be capable of maintaining the facility properly. Even where maintenance of a private facility is enforceable by a governmental entity under regulations or ordinances, consistent performance of facility maintenance will not be accomplished unless the owner has adequate resources for this work. If the owner does not have these resources, the enforcement process is likely to become frustrating for both the owner and the enforcing agency.

Actual ownership of a SWMF may change throughout the life of the facility. The original owner would normally be the agency or developer who constructed the facility. In the case of publicly-owned facilities, ownership may remain with the original governmental entity for the life of the facility. However, with privately-owned facilities, ownership may change hands several times throughout the facility's life. The private individual or corporation which ultimately becomes responsible for maintenance of the facility may not be the same person or entity which originally planned, designed, and constructed the facility. This is particularly common with residential development. For example, a developer may construct condominiums or townhouses where, ultimately, the ownership of the common facilities, including the SWMF, resides with the condominium corporation or homeowners association. In this case, the people responsible for maintenance of the facility most likely had nothing to do with its planning, design, or construction and may have little appreciation for its purpose, function, or maintenance. Combined with a lack of either proper management ability or financial resources on the part of the "new" owners, the SWMF is virtually doomed to neglect.

OWNERSHIP AND MAINTENANCE RESPONSIBILITY

From the perspective of maintenance responsibility, perhaps the most undesirable ownership situation is where a detention basin or other SWMF is located on portions of several single family residential properties and all the individual property owners are collectively responsible for its maintenance. In this situation, it can readily be seen that the homeowners may be able to accomplish routine tasks such as grass cutting or litter removal, but more sophisticated maintenance procedures such as sediment removal and structural repairs would generally be beyond their capabilities.

It is both interesting and ironic to note that, when ownership of a SWMF changes over the facility's life, the success or failure of that entire process is usually determined before the facility even exists. It's fate is decided during the planning and design phase through the governmental review and approval process.

Essentially, governmental entities have two options for establishing ownership responsibility:

1. Passively let the facility ownership changes take place in accordance with the applicant's proposal (either, by chance, with or without proper planning for future ownership) or;
2. Take an active role in planning the evolution of the facility's ownership to insure that there is a responsible party capable of performing the required maintenance at all times.

Unfortunately, the importance of proper ownership throughout the life of a SWMF is often overlooked during the review and approval process. However, in many respects, the details of the facility's ownership "plan" are as important as its technical design and structural details, since maintenance neglect by its owner could ultimately result in the failure of a SWMF.

D. OWNERSHIP-MAINTENANCE RESPONSIBILITY ARRANGEMENTS

Ownership of a SWMF, as with any other physical facility, can generally be divided into two categories: public or private.

Public ownership would include ownership by any governmental entity or public authority. Such public authorities might include those directly responsible for stormwater management or flood control, as exist in some states, or those responsible for some other public function such as transportation, water supply, or wastewater treatment which, by necessity, include a SWMF as an ancillary part of their

OWNERSHIP AND MAINTENANCE RESPONSIBILITY

operations. Where the public owner is a governmental entity such as a municipality, county, or state, that owner may also have regulatory power over the approval of the SWMF, and, in some cases, may simultaneously be subject to regulatory review by a higher level of government. Depending upon the existing regulations and level of enforcement, the governmental entity may also be subject to maintenance monitoring by a higher level of government.

Private owners of facilities may include corporations, condominium or homeowners associations, and private individuals. As described above, the ultimate owners of a SWMF may not necessarily be the same individuals or groups responsible for its planning, design and construction. Depending upon the regulations of the governmental agencies having jurisdiction over a particular SWMF, the private owners may be subject to monitoring of their maintenance activities or they may be left strictly on their own. Unfortunately, this latter condition is more likely to result in neglect of proper maintenance, particularly where the owners do not fully appreciate the purpose and importance of the SWMF and its maintenance.

Basic arrangements for SWMF ownership and maintenance responsibility include the following:

1. Public Ownership and Maintenance.
2. Private Ownership and Maintenance.
3. Private Ownership and Public Maintenance.

Under the first two categories, the facility owner, whether public or private, also provides for its maintenance. The third category, where a public agency maintains a privately owned SWMF, should be seriously considered in those instances where the private owner is not likely to have the institutional, managerial, or financial resources to properly maintain the facility. As an example, consider the situation where a SWMF is constructed on properties owned by one or more single family homeowners.

It should also be noted that, in the above situation, the existence of a homeowners association does not necessarily provide adequate assurance that proper SWMF maintenance will be performed, unless the association is also responsible for the maintenance of other real property of significant value, such as a swimming pool complex or other large recreational facility, for which it has both an effective maintenance management program and a reliable source of adequate funding. However, if the homeowners association is formed solely for the purpose of designating or delegating responsibility for SWMF maintenance, experience has shown that it is unlikely that the association will remain viable. Converse-

OWNERSHIP AND MAINTENANCE RESPONSIBILITY

ly, if there are other compelling reasons for the association to exist, then it is more likely to succeed and potentially provide the required SWMF maintenance. Proper facility maintenance is not guaranteed, but it certainly has a better chance of success where the organization also provides similar maintenance for other onsite facilities.

When a governmental entity requires that a SWMF be provided, that entity must also address the probability of proper maintenance responsibility being reasonably executed by the eventual facility owner. In instances where it is probable that the eventual owner will not have the required resources and abilities to effectively provide for facility maintenance, and particularly where failure of the facility could have significant adverse impacts, the public entity should seriously consider assuming the maintenance responsibility itself. The public entity should then require that it be granted legal access to the facility for maintenance purposes through the granting of appropriate easements or be given the facility property outright.

It should be noted that acceptance of maintenance responsibility and associated easements or property ownership by the public entity will also include acceptance of certain legal liabilities for the facility. The degree of liability will vary in accordance with the type of facility and its particular location, features, and other circumstances. It may be appropriate to estimate the value of this potential liability, perhaps in terms as simple as liability insurance costs, over the estimated life span of the project. If the potential liability costs are considered significant, then appropriate provisions should be made to secure necessary financing. Liability insurance costs could also be a factor in determining land acquisition costs.

Due to both the potential liability costs and the cost of the actual maintenance itself, public entities may be adverse to owning SWMFs, particularly those located on private property. However, these costs must be evaluated in terms of the threat posed to the public by a SWMF which is not properly maintained by its private owner. In addition, if the private owner does not have adequate maintenance resources, the public entity may find itself, in time, maintaining the SWMF anyway through default, regardless of the preparations it took to avoid such an eventuality. Therefore, it is extremely important that proposed arrangements for SWMF ownership and maintenance be fully evaluated during the facility's planning, design, and review phases, and that provisions be made for public maintenance of the facility where it is unlikely that it will be properly maintained by the private owner. Factors to be considered when evaluating a private owner's ability to properly maintain a SWMF are presented below.

OWNERSHIP AND MAINTENANCE RESPONSIBILITY

E. EVALUATING PRIVATE OWNERS' MAINTENANCE CAPABILITIES

The probability of proper facility maintenance being accomplished by a private owner would seem to be in direct proportion to both the vested interest that owner has in a well-maintained SWMF and the existence of other facilities for which the owner can and must provide similar maintenance. More simply put, if the private owner is concerned with the proper functioning and appearance of the SWMF and must also maintain other grounds or facilities (for which he has appropriate funding, manpower and equipment), then it is more likely that he will also properly maintain the SWMF. If, on the other hand, the owner does not appreciate the importance of the SWMF and looks upon it as something which he has been forced to provide, or if he does not otherwise have the proper staff and equipment for maintaining the facility, then it is more likely that the maintenance will be neglected.

Some general comments regarding various categories of private owners of SWMFs are presented below:

1. Private Corporations

Private corporations which own industrial parks, commercial sites, or similar properties are generally capable of and willing to provide adequate maintenance of SWMFs. This is particularly true if the corporation is conscious of its public image, both as observed at its grounds and facilities and as perceived by the neighboring community. Very often, a SWMF is included in the general landscape of a corporate-owned site, making the facility's maintenance a key element in the overall site's appearance and appeal. Such a corporation can be expected to have the manpower and equipment required to provide for proper SWMF maintenance and, in the event of problems, the public agency monitoring facility maintenance will be directing its enforcement actions against an entity with the capability and financial resources to correct the problems.

2. Condominium Associations and Cooperative Apartment Owners

Condominiums and co-op apartments characteristically have areas of common ownership and use. As such, their owners can generally be considered capable of providing proper SWMF maintenance in cases where they 1) must also provide for the maintenance of a significant extent of grounds, roads, and other facilities for the common use of the residents and 2) have an effective mechanism for the collection of funds to finance such maintenance. However, maintenance problems may still arise if there is a lack of concern on the part of the

OWNERSHIP AND MAINTENANCE RESPONSIBILITY

owners over their image and standing with the surrounding community.

For example, if a SWMF is located in a highly visible area of a condominium or co-op site, it may receive a high degree of maintenance in order to provide an aesthetically pleasing landscape to the neighboring community. However, if it is located in a remote or obscure portion of the site, there may be a tendency for maintenance neglect, particularly if the facility provides no direct benefit, such as active or passive recreation. Where there is no concern for community image or standing, SWMF maintenance may suffer, regardless of the facility's location or visibility. Fortunately, in this case, the public agency monitoring facility maintenance still has a corporation with significant financial resources against which it can direct its enforcement actions.

3. Single Family Homeowners Associations

Similar to condominiums and cooperative apartments, the owners association created for a group of single family homes may exist in the form of a corporation. However, unlike condominium or co-op owners, a single family homeowners association will not necessarily have to provide maintenance for any substantial common grounds or facilities other than the SWMF itself. It may therefore lack the managerial and financial resources required for proper SWMF maintenance. A homeowners association which is responsible for the maintenance of other significant real assets, such as major recreational facilities, can be expected to have the capability and resources to properly maintain a SWMF. However, where there are no other significant, compelling reasons for the homeowners association to exist, it is not likely to be an effective and responsible provider of SWMF maintenance.

Therefore, when the public agency monitoring SWMF maintenance agrees to entrust a single family homeowners association with SWMF maintenance, it should be assured that the association exists as a corporation with adequate tangible assets which can be effectively targeted and utilized during any enforcement action. It should also be remembered that a homeowners association created for no other reason than to be assigned the responsibility for SWMF maintenance is not likely to remain viable. Once it ceases to exist in either a literal or practical sense, maintenance of the SWMF will also cease, unless it is assumed by the agency.

OWNERSHIP AND MAINTENANCE RESPONSIBILITY

4. Individual Homeowners

With the exception of minor SWMFs such as onsite seepage pits or dry wells, it is unlikely that an individual homeowner will have the capability or resources to properly maintain a SWMF. While the individual homeowner may be capable of maintaining the grass or other vegetative cover, he or she will generally not be capable of undertaking anything more strenuous or sophisticated. If a proposed single family development requires the construction of an onsite SWMF, then appropriate provisions should be made for its maintenance by someone other than an individual homeowner or homeowners. This may include the assumption of maintenance responsibility by the municipality, county, or other regulatory agency. Another alternative may be to waive construction of the onsite facility and to require an appropriate contribution to an off-site regional facility maintained by a more capable entity. This, of course, will depend upon the importance of the onsite facility in controlling runoff between the development site and the site of the regional facility.

Finally, due to both the nature of single family residential developments and the long term significance of SWMF maintenance, it is important that the public agency reviewing the single family development proposal (and its SWMF) have an accurate and assured understanding of the intended facility ownership and maintenance arrangements prior to granting final approval. Unlike projects under single ownership, the multiplicity of owners inherent in a single family residential development can severely hinder any maintenance enforcement actions taken without such prior understanding.

F. DESIGNATION OF ORGANIZATIONAL RESPONSIBILITY

Unfortunately, experience has shown that SWMF maintenance often suffers when an organization (as opposed to an individual) is responsible for its performance. This is due to the vague, diffuse, or fractured designation of responsibility often encountered in organizational structures. Therefore, in such cases, it is important that a specific individual within that organization (usually by virtue of his position or experience) be charged with the overall responsibility for facility maintenance.

For example, if one person within an organization is responsible for grass mowing, a second person responsible for removal of trash and debris, and a third responsible for structural inspections and repairs, with no one individual responsible for overall coordination and follow-up, then the facility maintenance program will only be as good as the weakest link in the chain of responsibility. On the other

OWNERSHIP AND MAINTENANCE RESPONSIBILITY

hand, if a specific individual or official is charged with the overall responsibility for maintenance of the SWMF and is given the authority and resources to insure its performance, that individual can then institute controls to assure that maintenance personnel, who may be responsible for various individual tasks, carry out their responsibilities.

A discussion of specific SWMF maintenance procedures is presented in Chapter Four - Maintenance Equipment and Procedures. This Chapter of the MAINTENANCE MANUAL includes sample work orders and checklists, maintenance logs, and inspection checklists and logs for SWMF maintenance. This information can greatly assist the designated individual within an organization responsible for overall SWMF maintenance. It is not intended that the individual assigned the responsibility for facility maintenance should personally complete these various forms, but rather that they serve as a tool for those reporting to him to systematically record information pertaining to facility maintenance. The designated individual may further delegate to subordinates the responsibility for completing these forms. However, the designated individual should periodically review appropriate information and ask for reports from his subordinates so that he is fully informed as to the extent of maintenance being performed and the need for special actions or changes in procedures.

Designation of the individual responsible for SWMF maintenance by the organization which owns the facility deserves careful consideration. This individual should be vested with sufficient authority to establish procedures and priorities for the maintenance personnel. This individual should also have a thorough understanding of the purpose and function of SWMFs and an appreciation of both the consequences of facility failure and the important role maintenance plays in preventing such occurrences. On the other hand, the individual should not be at such a high level of authority in the organization that coordination of the maintenance program becomes inefficient or ineffectual.

In a private corporation, the individual responsible for maintenance of buildings and grounds would likely be the individual responsible for maintenance of the SWMFs as well. Municipalities and counties generally have a Department of Public Works. Depending upon the size of this Department, either the head of the Department or someone at the next lower level of management in an appropriate section of the Department would be the appropriate individual to be assigned the overall responsibility for SWMF maintenance.

In any organization, the basic priorities of that organization are generally established from the top down. Therefore, it is important that the supervisor of the designated individual responsible for SWMF maintenance also make it his

OWNERSHIP AND MAINTENANCE RESPONSIBILITY

concern to periodically inquire as to the status of the maintenance program. Ultimately, it is the responsibility of those empowered to provide the necessary financing to set appropriate priorities. The designated individual responsible for SWMF maintenance may also be responsible for maintenance of other types of facilities, all demanding manpower and financial resources from the same staff and budget. Where budgets are inadequate, the actual priorities which govern the maintenance program may vary from those initially established, in accordance with the perceived desires of those in positions of authority. For example, if there is a shortfall in the maintenance budget and the chief executive officer or councilman in charge of public works is constantly inquiring as to the status of the parking lot repair or sidewalk reconstruction, it is these items which will effectively receive a higher priority. The unmentioned SWMFs may become neglected. Unfortunately, these facilities are often taken for granted until a problem arises.

While it is recognized that the chief executive officer of a corporation or the chief elected official of a public entity has many responsibilities and concerns, it is also important that this individual recognize the importance of the SWMFs and the need for their maintenance. His concerns should be communicated down the organizational structure to the individual who actually accomplishes the tasks in the field. The chief official must also provide appropriate financing so that the maintenance can be reasonably accomplished, thus avoiding undesirable consequences and problems resulting from facility failure.

G. ADOPT A SYSTEM

Perhaps the best recipe for ensuring that proper SWMF maintenance is performed is to adopt an official maintenance system. Primary actions in establishing a SWMF maintenance system should include designating a key individual to be responsible for the overall maintenance program, providing appropriate financial, material, and human resources, and establishing controls and feedback. Brief descriptions of these key actions are presented below.

- 1. Designate a Key Individual to be Responsible for SWMF Maintenance** - This concept is reviewed in considerable detail in Section F above. A major consideration is to appoint a key individual high enough in the organization to have sufficient authority to establish priorities, yet close enough to the maintenance and supervisory personnel to have effective communication and coordination.

OWNERSHIP AND MAINTENANCE RESPONSIBILITY

2. **Educate the Key Individual** - The key individual designated above should be made aware of the importance of the SWMFs and the direct possibility and consequences of facility failure if maintenance is neglected. He or she should have a clear understanding of the priority SWMF maintenance has relative to his or her other responsibilities. While SWMF maintenance may not be the top priority, it should be high enough to ensure that adequate maintenance is performed.

3. **Establish Procedures** - Appropriate procedures should be established for developing maintenance budgets, inspecting facilities, and scheduling and performing actual maintenance work on both a routine and emergency basis. The procedures should also include a means for providing feedback of information from field personnel to supervisory personnel on a routine or priority basis, as the need arises. The procedure should include proper record keeping to provide verification of work actually completed and to assist in preparing future budgets. Sample forms to be utilized for these purposes are included in Chapter Four - Maintenance Equipment and Procedures.

4. **Develop Facility Plans and Maps** - Record drawings of constructed SWMFs should be maintained at a location convenient for use by key personnel. When an owner or public agency is responsible for maintenance of multiple facilities, a site inventory map should be conveniently available, showing the location and general type of facility. Regulatory agencies responsible for enforcement of maintenance or for review of planning and approval of new facilities would also find it useful to have an overall map indicating the location of major SWMFs within their jurisdiction. The map could also include designations of existing or proposed regional SWMFs so that the present or future existence of these facilities can be considered at the time of review of individual site proposals.

H. MAINTAINING NON-OWNED FACILITIES

Where one entity assumes or is delegated the responsibility for maintenance of a SWMF located on land owned by another entity, adequate provision must be made for both legal and physical access to the facility. The most common occurrence of this type is the maintenance by a county or municipality of a SWMF located on private land. Adequate provision must be made in the project review stage to ensure that appropriate easements are designated, including buffer zones and staging areas for equipment, as appropriate to the facility. These easements must also include provision for access routes from the public right-of-way or along maintained access routes. Gates should be provided at appropriate locations in fenced areas. An access route should be ade-

OWNERSHIP AND MAINTENANCE RESPONSIBILITY

quately constructed and graded to permit entry by appropriate vehicles and equipment.

During the project review process, the key individual who will be responsible for overall facility maintenance should have the opportunity to review the project plans and make recommendations regarding project features which will affect the maintenance effort. While the astute design engineer may do his best to include all maintenance considerations in the facility design, the individual who is actually responsible for maintenance in the field may be able to provide meaningful suggestions, based upon his experience and observations.

Assumption of the responsibility for maintenance of a SWMF may also include assumption of an associated liability. The significance and potential financial impact on the agency due to this additional liability will depend upon the character and nature of the project and surrounding areas. Where a major structure such as a dam is involved, the agency assuming the maintenance responsibility may wish to consult with its insurance adviser to determine the additional cost of liability insurance. This liability insurance cost plus the other costs associated with maintenance of the facility can then be estimated for an appropriate term, such as 25 years, and the present worth of these services computed. Where an appropriate mechanism is in place for collecting and managing developer contributions, the facility owner could be required to provide appropriate financing to offset this anticipated maintenance and insurance cost.

I. SUMMARY

In any discussion of SWMF maintenance, facility ownership is an important topic since, in most cases, it is the owner who will be responsible for the long term maintenance of the facility. Ideally, the owner will recognize and fulfill his maintenance responsibilities and recognize that he may be liable for the consequences of facility failure if he fails to provide adequate maintenance. Unfortunately, all owners may not recognize these responsibilities and liabilities, or may lack adequate resources to fulfill them. Therefore, the reviewing and approving agency should be reasonably certain that the person or organization which will be responsible for maintenance will have the legal, institutional, managerial and financial resources necessary to accomplish the required maintenance. While some private entities will possess the necessary resources and abilities, others will not and it may be necessary for a public agency to assume the responsibility for facility maintenance, either by intention or by default.

OWNERSHIP AND MAINTENANCE RESPONSIBILITY

When an organization is responsible for SWMF maintenance, a key individual within the organization must be assigned the direct responsibility for overall facility maintenance and be vested with adequate authority to carry it out. This key individual must be aware of the purpose of the SWMFs and consequences of facility failure, particularly those failures caused by inadequate maintenance. Key executive officials of the organization should also have an appreciation for the function and purpose of SWMFs, and should establish and communicate to key personnel an appropriate priority for facility maintenance relative to other responsibilities. An orderly maintenance system, including appropriate procedures for establishing budgets, conducting inspections, ordering work, and verifying completion should be established. Provisions should also be made for feedback from field personnel regarding field conditions or other problems associated with SWMF maintenance. An overall site inventory and location map will prove useful in managing the maintenance efforts at multiple facilities.

A public agency assuming responsibility for a non-owned SWMF should give consideration to any associated liability they are also assuming. The cost of insurance to cover such liability as well as other maintenance costs can be estimated for a selected period of time, such as 25 years. The present worth of these costs can then be used as the basis for a financial contribution by the facility owner or builder.

Since a lack of adequate SWMF maintenance may ultimately result in failure of a facility, consideration of both the immediate and eventual ownership of, and maintenance responsibility for, a proposed SWMF is an essential component of any project review. While often overlooked or given only token review, consideration of these aspects of a proposed SWMF is as important as the review of technical design details and construction specifications.

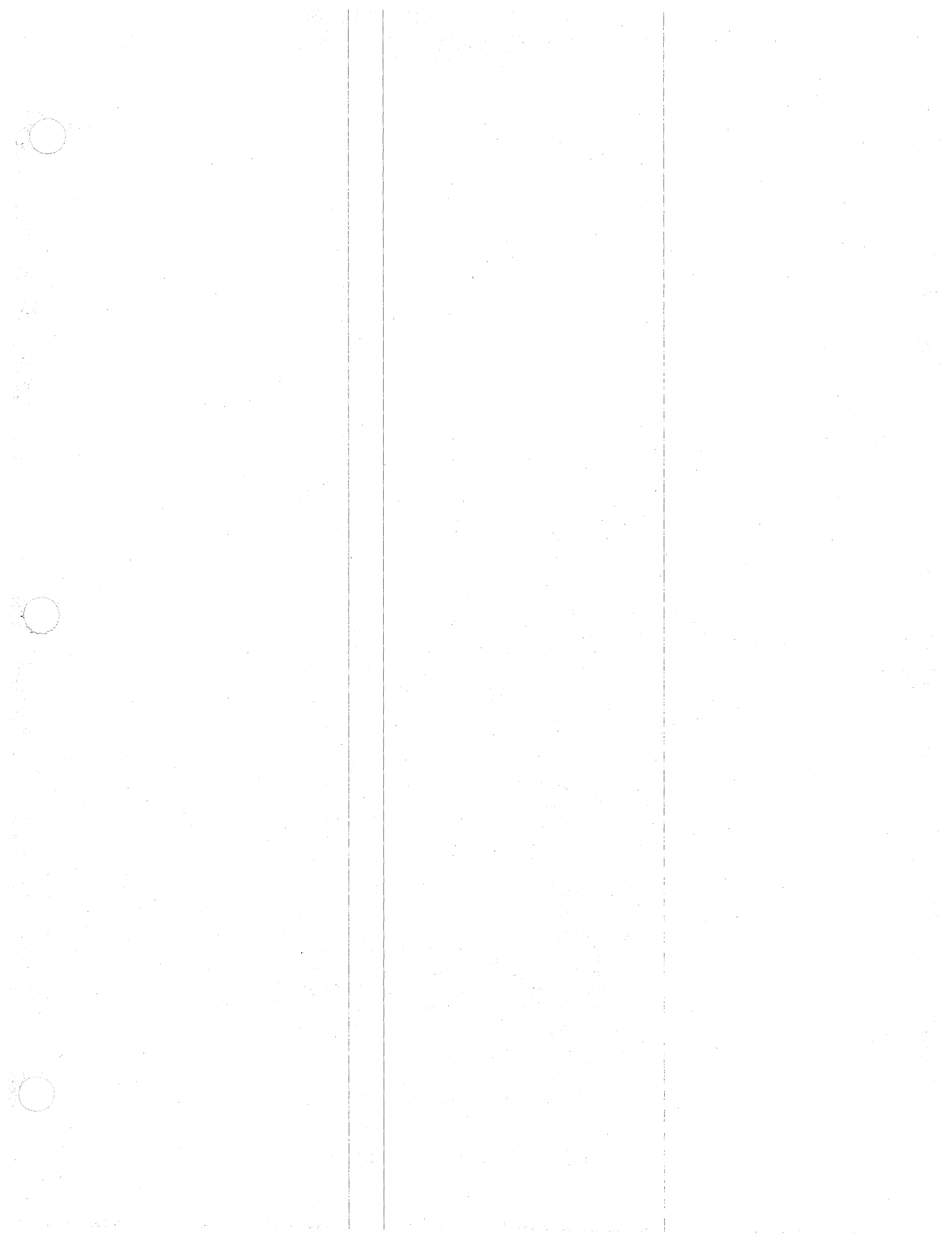

**NEW JERSEY
DEPARTMENT OF ENVIRONMENTAL PROTECTION
STORMWATER MANAGEMENT FACILITIES
MAINTENANCE MANUAL**

**CHAPTER TWO
PLANNING AND DESIGN GUIDELINES**

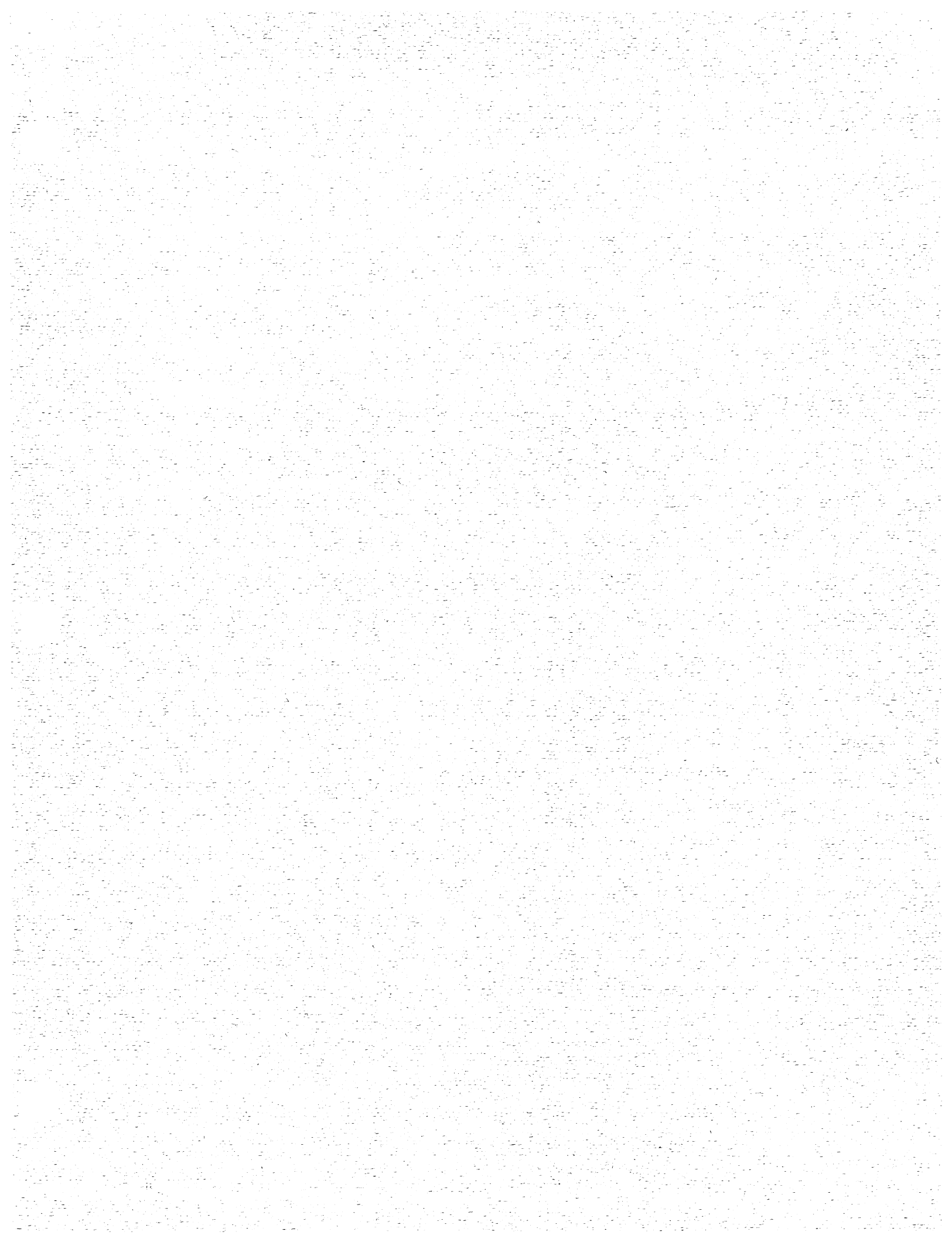

N.J. DEPARTMENT OF ENVIRONMENTAL PROTECTION
STORMWATER MANAGEMENT FACILITIES MAINTENANCE MANUAL

CHAPTER TWO - PLANNING AND DESIGN GUIDELINES

TABLE OF CONTENTS

A. OBJECTIVES	PLAN-1
B. INTENDED READERS	PLAN-1
C. DEFINITIONS	PLAN-2
D. WHY WORRY ABOUT MAINTENANCE NOW?	PLAN-3
E. GENERAL MAINTENANCE CONSIDERATIONS	PLAN-6
F. WHO, WHAT, WHEN, AND WHERE?	PLAN-8
G. PLANNING AND DESIGN GUIDELINES	PLAN-9
* PLANNING AND DESIGN GUIDELINES FOR STORMWATER DETENTION FACILITIES	PLAN-12
* PLANNING AND DESIGN GUIDELINES FOR STORMWATER INFILTRATION FACILITIES	PLAN-29
* PLANNING AND DESIGN GUIDELINES FOR STORMWATER RETENTION FACILITIES	PLAN-41

TABLE 2-1 SWMF COMPONENT DESCRIPTIONS	PLAN-10

PLATE 2-A DETENTION BASIN ORIFICE AND WEIR PLATES .	PLAN-16
PLATE 2-B LOW FLOW CHANNELS AND UNDERDRAINS	PLAN-21
PLATE 2-C DETENTION BASIN TRASH RACKS	PLAN-25
PLATE 2-D INFILTRATION BASIN UNDERDRAINS	PLAN-31
PLATE 2-E NONVEGETATED INFILTRATION BASIN BOTTOMS .	PLAN-33
PLATE 2-F RETENTION BASIN SIDE SLOPES	PLAN-44
PLATE 2-G RETENTION BASIN ORIFICE AND WEIR PLATES .	PLAN-46
PLATE 2-H RETENTION BASIN TRASH RACKS	PLAN-52



PLANNING AND DESIGN GUIDELINES

A. OBJECTIVES

This Chapter of the **STORMWATER MANAGEMENT FACILITIES MAINTENANCE MANUAL** presents both general recommendations and specific guidelines to be used in the planning, design, and review of detention, retention, and infiltration facilities. The Chapter has been prepared with several purposes in mind:

- * To describe the character, magnitude, and extent of stormwater management facility maintenance problems actually observed in the field and the type and degree of maintenance efforts required to address them.
- * To demonstrate the direct correlation between unwise, uninformed, or otherwise incorrect planning and design decisions and subsequent facility maintenance problems.
- * To emphasize the ability of sound planning and design decisions and thorough and enlightened review procedures to eliminate, reduce, or facilitate maintenance efforts at stormwater management facilities.
- * To illustrate the cost-effectiveness of eliminating maintenance problems and/or reducing required maintenance efforts during a facility's planning, design, and review stages.
- * To encourage planners, designers, and reviewers to consider maintenance to be as important as the hydrologic, hydraulic, structural, and aesthetic aspects of a proposed stormwater management facility.
- * To present planning and design guidelines that will promote stormwater management facilities that are as safe, easy, and economical to maintain as possible.

B. INTENDED READERS

In light of the objectives listed above, those who will benefit most from this Chapter are:

- * **Project Planners and Designers** responsible for the preconstruction development of stormwater management facilities.
- * **Engineering Department, Planning Board, and other government agency personnel** responsible for the review of proposed facility designs.

In addition, the information contained in this Chapter can alert:

PLANNING AND DESIGN GUIDELINES

- * **Construction Managers**
- * **Construction Inspectors**
- * **Contractors**

of the need to comply with the design plans and specifications as much as possible and to coordinate any field changes to the design with the people who developed it.

Finally, the Chapter can provide:

- * **Project Managers**
- * **Owners**
- * **Government Officials**

with beneficial insight into more effective facility planning, design, and review procedures.

C. DEFINITIONS

Before getting into specific guidelines, let's look at some of the reasons why we should have more than just a passing interest in maintenance during the planning, design, and review stages of a stormwater management facility. To simplify our discussion, we'll substitute the abbreviation SWMF for "Stormwater Management Facility" and we'll use it to represent detention, retention, and infiltration facilities. To further simplify our discussion, we'll agree on the following facility definitions:

Detention Facility: A SWMF which temporarily impounds runoff and discharges it through a hydraulic outlet structure to a downstream conveyance system. While a certain amount of outflow may also occur via infiltration through the surrounding soil, such amounts are negligible when compared to the outlet structure discharge rates and are, therefore, not considered in the facility's design. Since a detention facility impounds runoff only temporarily, it is normally dry during non-rainfall periods.

Infiltration Facility: A SWMF which temporarily impounds runoff and discharges it via infiltration through the surrounding soil. While an infiltration facility may also be equipped with an outlet structure to discharge impounded runoff, such discharge is normally reserved for overflow and other emergency conditions. Since an infiltration facility impounds runoff only temporarily, it is normally dry during non-rainfall periods.

PLANNING AND DESIGN GUIDELINES

Retention Facility: A SWMF which, similar to a detention facility, temporarily impounds runoff and discharges its outflow through a hydraulic structure to a downstream conveyance system. Unlike a detention facility, however, a retention facility also includes a permanent impoundment and, therefore, is normally wet, even during non-rainfall periods. Storm runoff inflows are temporarily stored above this permanent impoundment.

Finally, to further organize our presentation and provide thorough coverage of all pertinent aspects of SWMF's, let's break each facility type into its various major components. These are:

- | | |
|---------------------------------------|----------------------|
| A. Bottoms and Permanent Pools | F. Emergency Outlets |
| B. Dams, Embankments, and Side Slopes | G. Low Flow Measures |
| C. Principal Outlets | H. Vegetative Cover |
| D. Outflow Systems | I. Trash Racks |
| E. Inlets | J. Access |
| | K. Perimeters |

While most of the component names listed above are self-explanatory, complete descriptions of each are presented in Table 2-1 on Page Plan-10. Feel free to refer to them whenever necessary.

D. WHY WORRY ABOUT MAINTENANCE NOW?

We're glad you asked that question. And now is a perfect time to answer it, before we get into specific planning and design guidelines.

Prior to the development of this manual, the Department of Environmental Protection conducted an extensive field investigation of more than 50 SWMFs located throughout the State. This investigation was conducted, in part, to identify the nature, severity, and extent of maintenance problems at actual SWMFs and determine the role that planning and design played in the creation or worsening of those problems. Among other results, the field investigations revealed that most of the observed SWMF maintenance problems, including some which were virtually unsolvable without massive infusions of time, money, and hard work, could be traced to shortcomings in the planning and design process. These shortcomings may have been the result of a lack of effective planning and design standards, inadequate or inaccurate design and review procedures, or simply the failure to realize that, someday, someone would have to maintain the SWMF that, at the time, existed only on paper.

Regardless of the culprit, it can be seen that the elimination of these breakdowns in the planning, design, and review process will greatly reduce the incidence of SWMF mainten-

PLANNING AND DESIGN GUIDELINES

ance problems and the level of required facility maintenance. Is it worth the effort? Let's take a look.

As we're all aware, maintenance is a fact of life with a SWMF. The continued safe and effective operation and the aesthetic quality of any SWMF are contingent upon thorough maintenance. Ideally, the level of this required maintenance should be minimal, limited to such routine tasks as regular grass mowing, trash and debris removal, and periodic de-silting. All too often, however, required maintenance also includes mosquito control, structural repairs, erosion control, and such emergency efforts as debris removal and slope stabilization during actual storm events. In addition, many routine maintenance tasks often become difficult or even impossible to perform due to such obstacles as access restrictions, steep side slopes, and muddy, soggy bottoms. The manual labor involved can be extremely difficult and even dangerous at times.

These situations need not occur. The guidelines and recommendations presented in this Chapter, when combined with ingenuity, experience, and creativity, will result in SWMFs that require the minimum practicable levels of maintenance and incur the lowest possible costs. This cost factor deserves closer attention.

In addition to its other not-so-endearing qualities, maintenance is a costly undertaking. Unlike planning and design, it is also a continual undertaking, lasting for the life of the SWMF. As facility owners can tell you, maintenance expenditures continue long after the designer's bill has been paid and, with rising labor, equipment, and disposal costs, present financing requirements can only be expected to increase. Therefore, it can be seen that (1) the cost of maintenance must be included in the facility's total lifetime cost and (2) a reduction in required maintenance through sound planning and design can significantly reduce this overall cost.

For example, let's assume that a particular SWMF requires an annual maintenance effort of (let's see, cut the grass.... remove the debris...steep side slopes....wet bottom....two man-days....carry the one...) \$2,500. If that required maintenance effort can be reduced by 40 percent through an increased, one-time planning and design effort costing \$3,000, the facility's owner will see a return on his additional design cost in only 3 years. Even if maintenance is only reduced by 20 percent, the additional design cost will be recovered in 6 years, which is still a much shorter period than the expected life of the facility. If the maintenance of a privately constructed SWMF will be assumed by a municipality, the inclusion of maintenance considerations in the town's review and approval process can result in similar cost savings for its taxpayers.

PLANNING AND DESIGN GUIDELINES

This simplistic example does not include changes in interest rates and maintenance costs, disposal problems, or other variables, but it clearly demonstrates how efforts to reduce SWMF maintenance during the planning and design stage can have a decidedly positive benefit/cost ratio. It is also important to recognize that, while having a great impact on reducing long-term maintenance costs, the use of the guidelines and recommendations presented in this Chapter should have a minimal impact on increasing actual planning, design, review, and even construction costs. In addition, as these guidelines become more a part of our regular planning, design, and review procedures, the extra cost to implement them will become less and less.

It is difficult to put an exact dollar value on all of the benefits to be gained from the planning and design of a "minimum maintenance" SWMF. Too often, as field inspections have shown, a poorly designed SWMF can become a serious safety hazard, despite considerable maintenance efforts to prevent it. These hazards range from unsafe structural conditions or inadequate hydraulic capacity, which may threaten downstream lives and property, to unintended standing water, which poses a drowning threat to children and adults alike.

One safety hazard of particular significance is the creation of mosquito breeding habitats. Due to their ability to transmit viruses and other diseases, mosquitoes must be controlled, particularly in developed areas where contact with humans and domestic animals is the greatest. Unfortunately, as can be seen, these are the very same areas where most SWMFs are constructed. All mosquitoes have four stages of development - egg, larva, pupa, and adult. The adult female lays her eggs on still bodies of water or, in some species, on moist surfaces such as mud or fallen leaves. The water bodies need only be mere inches in depth and can be found in surface depressions, scour holes, tire ruts, and even in the voids of riprap linings. Each batch may contain from 100 to 300 eggs and, depending upon the weather and her stamina, the female may repeat the process several times without mating again. Suspended by the water, the eggs quickly hatch into larvae, which then grow rapidly into pupae and then emerge as flying adult mosquitoes. It is possible for mosquitoes to complete their life cycle in 7 to 10 days, with approximately half being spent in the aquatic stage. Therefore, it can be seen that, wherever water remains still or stagnant for only 4 to 5 days, at least one generation of mosquitoes numbering upwards of several hundred can be bred. The longer the water remains stagnant, the greater the potential for mosquito breeding.

PLANNING AND DESIGN GUIDELINES

While effective control techniques have been developed and the various State and County mosquito extermination commissions have performed admirably in preventing outbreaks of serious mosquito-related problems, such efforts are extremely labor intensive and costly. It makes greater sense to prevent the creation of a mosquito breeding habitat during the planning and design of a SWMF than to control it after the facility, and the homes, stores, and offices around it, are constructed. While difficult to quantify, the benefits to the local community of preventing such an occurrence can be tremendous.

Another significant benefit of SWMFs designed for minimum maintenance that is difficult to quantify is their aesthetic value. As discussed above, SWMFs are normally constructed as part of residential, commercial, office, and industrial developments and, as such, are visible to people, be they residents, shoppers, or workers. While aesthetic values are highly subjective, it can be said with certainty that a poorly maintained, unsightly SWMF will have an adverse effect on the quality of those people's lives, regardless of how well the facility performs its stormwater management functions. Remember, a SWMF must function as designed on relatively few occasions (i.e., when it's raining) but the people who live, work or shop nearby must co-exist with it every day. Conversely, a well maintained, attractive SWMF can improve the quality of people's lives. As demonstrated in the preceding paragraphs, both the blame and credit for these two quality-of-life impacts must rest, in part, with the planning, design, and review of the particular SWMF.

By now, it should be apparent that two logical ways to keep maintenance-dependent SWMFs operating as intended are to reduce the level of required maintenance and facilitate the remaining maintenance tasks as much as possible. Faced with rising labor and equipment costs, growing disposal problems, manpower shortages, budget caps, and a continuing deterioration of our general infrastructure, the economic benefits of these practices should be just as apparent.

E. GENERAL MAINTENANCE CONSIDERATIONS

Now that you're convinced of the importance of including maintenance on your list of planning and design requirements, let's discuss some general SWMF maintenance considerations. Our goal in doing so is to have them become an integral part of the thought process of every SWMF planner and designer and automatically come to mind whenever a new facility is pondered, planned, or put on paper. Similarly, we'd like to see these considerations be a major part of every project review. Too lofty a goal, you ask? Not really, especially when you realize that they are based primarily on common sense and not on complex theories and equations

PLANNING AND DESIGN GUIDELINES

like some of those hydrologic, hydraulic, and structural aspects you've mastered. Compared to them, the recommended maintenance considerations should be easy to assimilate and even expand upon. Let's briefly review them:

1. Maintainability

It's a complicated word, but the concept it represents is simple: As you plan or design your stormwater management facility, always attempt to (1) eliminate as much required maintenance as possible; (2) facilitate the performance of those required maintenance tasks which still remain; and (3) prevent the need for emergency or extraordinary maintenance efforts. Project reviewers should use these three goals as criteria in deciding the suitability of proposed SWMFs.

2. Accessibility

In order for proper maintenance to be performed, the various components of the SWMF and, indeed, the facility itself must be accessible by maintenance personnel and equipment. Physical barriers such as fences and legal barriers such as easement restrictions can negate even the best maintenance programs. Keep in mind such things as depressed curbs, fence gates, access roads, manhole steps, handrails, and other access features when you're planning, designing, or reviewing your next SWMF. A complete list of access guidelines is presented in the following sections regarding Detention, Retention, and Infiltration facilities.

3. Durability

The use of strong, durable, and noncorrodible materials, components, and fasteners can greatly reduce required maintenance efforts. These include; lightweight, non-corrodible metals such as aluminum for trash racks, orifice plates, and access hatches; hardy, disease-resistant grasses for bottoms and side slopes; reinforced concrete for outlet structures and inlet headwalls; and gabions for channel and outlet linings. If you want your project to last, here's how to do it, and save maintenance dollars as well. The initial investment in high quality materials will pay off in the long run.

4. Constructability

The road to maintenance headaches is paved with good planning and design intentions that somehow went awry. Before the construction plans and specifications are completed and approved, make sure they are complete, clear, concise, and

PLANNING AND DESIGN GUIDELINES

ready to be turned over to the contractor. Try to organize and format them to assist rather than impede the contractor's work. Do they include a new idea or particularly complex component? If they do, then do yourself, the contractor, and future maintenance personnel a big favor by taking special efforts to highlight and detail it. Once construction has started, hasty field changes necessitated by incomplete or inattentive designs can result in costly maintenance problems.

F. WHO, WHAT, WHEN, AND WHERE?

The four W's. To help planners, designers, and reviewers produce "minimum maintenance" SWMFs, these four words or questions, if you will, are offered as reminders of the key items we've just discussed. Ask yourself these questions as you plan, design, or review a SWMF and you'll go a long way towards minimizing facility maintenance costs, efforts, and problems. After all, that's what this Chapter is all about.

* **WHO** will maintain the facility? It is better to find somebody now, before the facility is constructed, than after the grass is three feet high and the trash rack is clogged with debris. Once you have identified the responsible party, make sure that the facility's maintenance requirements are within the limits of their manpower, budget, equipment, and expertise. If not, either decrease the level of required maintenance or increase the available maintenance services before proceeding to construction. The planning and design phase can not be considered complete without providing for adequate maintenance.

* **WHAT** parts or components of the facility need to be maintained? What equipment and skills will be required? What can be done during the planning, design, and review stages to minimize and simplify these efforts? Each component of a SWMF should be evaluated to determine the answers to these questions.

* **WHEN** will the various maintenance tasks be required? Routine maintenance such as grass mowing may be performed on a sunny day, but emergency debris removal may be required during the middle of a tropical storm. Consider the conditions under which various maintenance tasks may be performed, particularly when developing or reviewing access and safety aspects.

* **WHERE** will maintenance be performed? Suitable access for personnel and equipment must be provided to each facility component. Where will equipment be staged? Where will grass, debris, and sediment be disposed? It's far better to select the place you want now than wind up with a place you don't want later.

PLANNING AND DESIGN GUIDELINES

G. PLANNING AND DESIGN GUIDELINES

Now that we've asked our Four W's, you may have a question for us; namely, **HOW?** The following pages present technical planning and design guidelines regarding each of the major components of detention, retention, and infiltration facilities. They are presented by facility type for simple reference and include descriptive drawings and diagrams. They're intended to assist planners, designers, and reviewers in developing SWMFs that require minimum levels of simple maintenance.

It is important to note that the guidelines presented on the following pages should be used in conjunction with all other hydrologic, hydraulic, structural, aesthetic, and legal requirements pertinent to the proposed facility and are not intended to replace them in any way. Remember also that each project and facility site is unique and may require additional or stricter measures. Therefore, the guidelines should be combined with ingenuity and creativity each time they're used.

Finally, the guidelines should serve to stimulate the development of additional planning ideas and design approaches to SWMF maintenance. To assist in this process, typical maintenance problems actually observed in the field are also presented for each facility type and component, just prior to the technical guidelines themselves. Keep these problems in mind as you review and implement the guidelines.

PLANNING AND DESIGN GUIDELINES

TABLE 2-1

N.J. DEPARTMENT OF ENVIRONMENTAL PROTECTION
STORMWATER MANAGEMENT FACILITY MAINTENANCE MANUAL

SWMF COMPONENT DESCRIPTIONS

COMPONENT	DESCRIPTION

PRINCIPAL OUTLETS.....	Hydraulic structures which control and convey the facility's discharge to the downstream outflow system. [Detention, Retention Facilities]
EMERGENCY OUTLETS.....	Hydraulic structures or spillways which convey emergency overflows. Includes approach and exit channels and appurtenances. [All Facility Types]
DAMS AND EMBANKMENTS.....	Structural fill or walls which impound runoff above existing grade. [All Facility Types]
BOTTOMS.....	Self-explanatory. [All Facility Types]
SIDE SLOPES.....	Slopes constructed through excavation or filling at dams, embankments, emergency spillways, perimeters, and other facility components. [All Facility Types]
TRASH RACKS.....	Devices located at upstream side of principal outlets and permanent pond drains to intercept trash and debris. [Detention and Retention Facilities]
LOW FLOW MEASURES.....	Surface and subsurface systems which convey low and dry weather flows without storage through facility to principal outlet. [Detention Facilities]

PLANNING AND DESIGN GUIDELINES

TABLE 2-1 (CONTINUED)

COMPONENT	DESCRIPTION
INLETS.....	Upstream surface and subsurface conveyance measures which discharge inflow into facility. [All Facility Types]
OUTFLOW SYSTEMS.....	Downstream surface and subsurface conveyance systems which receive outflows from principal outlets. [Detention and Retention Facilities]
PERIMETER.....	Area immediately adjacent to facility. [All Facility Types]
ACCESS.....	Accessibility of various components by maintenance personnel and equipment. [All Facility Types]
VEGETATIVE COVER.....	Self-explanatory. [All Facility Types]

NOTE: The component descriptions presented above have been developed for this SWMF Maintenance Manual. Other and/or additional descriptions may be employed in other publications and by other jurisdictions and agencies.

**PLANNING AND DESIGN GUIDELINES
FOR
STORMWATER DETENTION FACILITIES**

OVERVIEW

The following Planning and Design Guidelines are intended to assist in the creation of stormwater detention facilities that require the least practical level of maintenance. To accomplish this, they have been developed to (1) eliminate avoidable maintenance tasks, (2) minimize the long term amount of regular maintenance, (3) facilitate the performance of required maintenance tasks, and (4) reduce the potential for extensive, difficult, and costly remedial or emergency maintenance efforts.

As such, the guidelines presented herein are intended to supplement all other applicable detention facility standards, including those pertaining to hydrologic, hydraulic, structural, environmental, legal, and aesthetic aspects. They should also be used creatively in conjunction with all other applicable standards to create stormwater detention facilities that require minimum levels of maintenance performed with the least possible effort, time, and cost.

To assist in their use, the Planning and Design Standards are presented by detention facility component in the following order:

- | | |
|---------------------------------------|----------------------|
| A. Bottoms | F. Emergency Outlets |
| B. Dams, Embankments, and Side Slopes | G. Low Flow Measures |
| C. Principal Outlets | H. Vegetative Cover |
| D. Outflow Systems | I. Trash Racks |
| E. Inlets | J. Access |
| | K. Perimeters |

Detailed descriptions of each facility component listed above are presented in Table 2-1 on Page Plan-10.

At the beginning of each component section presented below is a list of common maintenance problems that the guidelines which follow have been developed to prevent. These problems, which have been identified through surveys, interviews, and site inspections, are intended to enhance the effectiveness of the guidelines by illustrating the guidelines' origins and purpose. They should also serve to stimulate the development of additional guidelines by detention facility planners, designers, and reviewers. More detailed information regarding detention facility maintenance problems and their causes can be found in the NJDEP's Ocean County Demonstration Study Report. Additional information regarding detention facility planning and design is published in the NJDEP's A Guide to Stormwater Management Practices in New Jersey.

PLANNING AND DESIGN GUIDELINES
DETENTION FACILITIES

A. BOTTOMS

Typical problems that impede or unnecessarily increase proper maintenance include:

- * Standing Water
- * Soggy Surfaces
- * Poor Grass Growth
- * Excessive Sedimentation
- * Limited Access

1. To promote complete emptying and prevent standing water or soggy surfaces, vegetated bottoms should have a minimum slope of 2 per cent and be graded to the outlet structure or low flow channel.

2. To promote complete emptying and prevent standing water or soggy surfaces, the lowest point in the bottom should be at least 4 feet above the seasonally high groundwater level or bedrock unless adequate subsurface drains are provided.

3. To provide adequate drying time, to avoid delaying scheduled maintenance efforts, and to prevent mosquito breeding, the maximum storage or ponding duration should not exceed 48 hours.

4. To avoid delaying scheduled maintenance efforts, topsoils and subsurface soils should be sufficiently permeable to allow both rapid infiltration and evaporation.

5. Subsurface drains connected to the principal outlet structure, low flow channel, or other discharge point are encouraged to promote quick and thorough drying of the facility bottom. In doing so, care should be taken to prevent stormwater inflow from inadvertently bypassing the basin's outlet controls. (See G. **LOW FLOW MEASURES** for additional details.)

6. To minimize routine grass maintenance such as mowing and fertilizing, the use of grass varieties that are relatively slow growing and tolerant of poor soil conditions are encouraged. Information on grass varieties and mixtures are available from such agencies as the local Soil Conservation Districts. (See H. **VEGETATIVE COVER** for additional details.)

7. To promote lasting growth, grasses and other vegetative covers should be compatible with the prevailing weather and soil conditions and tolerant of periodic inundation and runoff pollutants. (See H. **VEGETATIVE COVER** for additional details.)

8. To facilitate removal efforts, sedimentation should be promoted at localized, readily accessible areas. The use of sediment traps at inflow and outflow points is encouraged,

**PLANNING AND DESIGN GUIDELINES
DETENTION FACILITIES**

especially those lined with materials which have smooth, easily cleaned surfaces such as concrete. For this reason, the use of loose stone, riprap, and other irregular linings which require manual removal of weeds, sediment, and debris should be avoided.

9. Suitable access for maintenance personnel and equipment should be provided. (See J. ACCESS for details.)

10. Construction plans and specifications should include provisions which minimize the potential for localized settlement and subsequent ponding. These provisions include proper surface and subsurface soil characteristics, compaction requirements, grading equipment, and erosion control prior to the establishment of permanent vegetative cover.

11. All nonvegetative linings which are bordered by grass should be designed to permit complete mowing along all edges.

12. At subsurface detention facilities, suitable access, observation points and/or monitoring wells should be provided to facilitate inspection and cleaning. (See J. ACCESS for additional details.)

B. DAMS, EMBANKMENTS, AND SIDE SLOPES

Typical problems that impede or unnecessarily increase proper maintenance include:

- | | |
|---------------------|-------------------------|
| * Steep Slopes | * Long Slopes |
| * Poor Grass Growth | * Sloughing and Erosion |

1. For safe movement of personnel and safe operation of equipment, side slopes greater than 5 feet in height should not be steeper than 4 horizontal to 1 vertical. Side slopes less than 5 feet high should not exceed 3 horizontal to 1 vertical. Flatter side slopes are recommended wherever possible.

2. For safe movement of personnel and safe operation of equipment, side slopes steeper than 5 to 1 and higher than 15 feet should be terraced at their midpoints. The terrace should have a minimum width of 3 feet and should be graded at 2 per cent towards the lower half of the slope.

3. Suitable access to and along side slopes should be provided for maintenance personnel and equipment. (See J. ACCESS for details.)

4. Topsoil and vegetative covers must be protected from erosion caused by local runoff and the slope's steepness. Sur-

PLANNING AND DESIGN GUIDELINES
DETENTION FACILITIES

face and subsurface soil stabilization measures or non-vegetated linings should be utilized as necessary. In doing so, avoid the use of loose stones, riprap, and other irregular lining materials which require hand removal of weeds and debris and may be a safety hazard to maintenance personnel.

5. All nonvegetative linings which are bordered by grass should be designed to permit complete mowing along all edges.

6. The effects of rapid pool drawdown should be checked to prevent sloughing.

7. For safe movement of personnel and safe operation of equipment, fences should not be constructed within 3 feet of either the top or toe of any side slope that exceeds 5 horizontal to 1 vertical.

C. PRINCIPAL OUTLETS

Typical problems that impede or unnecessarily increase proper maintenance include:

- * Structural Deterioration
- * Limited Access
- * Corroded Appurtenances
- * Vandalism
- * Excessive Debris Accumulation

1. For durability, principal outlet structures should be constructed of reinforced concrete containing Type II cement and having a specified 28-day compressive strength of 3,000 PSI. Concrete shall be designed in accordance with all applicable codes and requirements, including the current edition of Building Code Requirements for Building Construction (ACI 318) of the American Concrete Institute.

2. For durability, all appurtenances, including access hatches, trash racks, gratings, railings, orifice and weir plates, and fasteners should be constructed of lightweight, noncorrodible materials. Material strengths should be sufficient to withstand design loads without damage or failure.

3. Outlet orifice and weir plates should be constructed from aluminum or other lightweight, noncorrodible material. The plates should be fastened to the structure with noncorrodible, removable fasteners. A gasket of neoprene or similar material should be placed between the plate and the structure wall. The opening in the structure wall over which the plate is bolted should have at least twice the area of the outlet orifice or weir to facilitate future expansion. (See PLATE 2-A for additional information.)

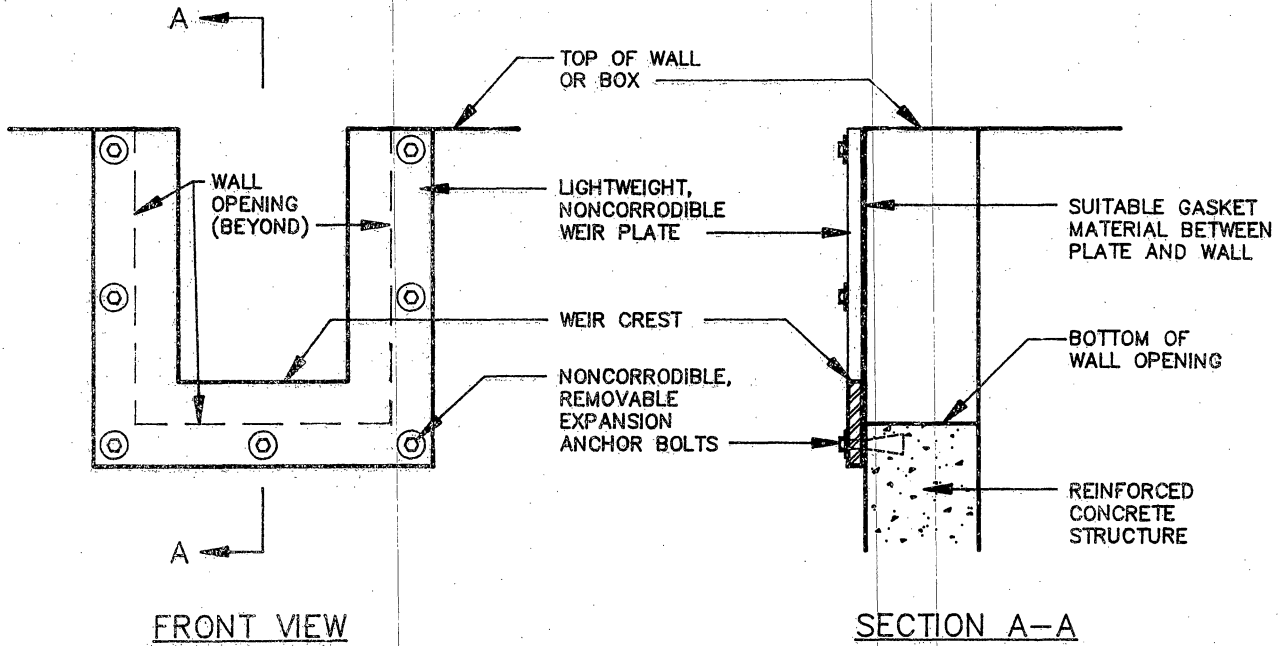

WEIR PLATE DETAILS
(NO SCALE)

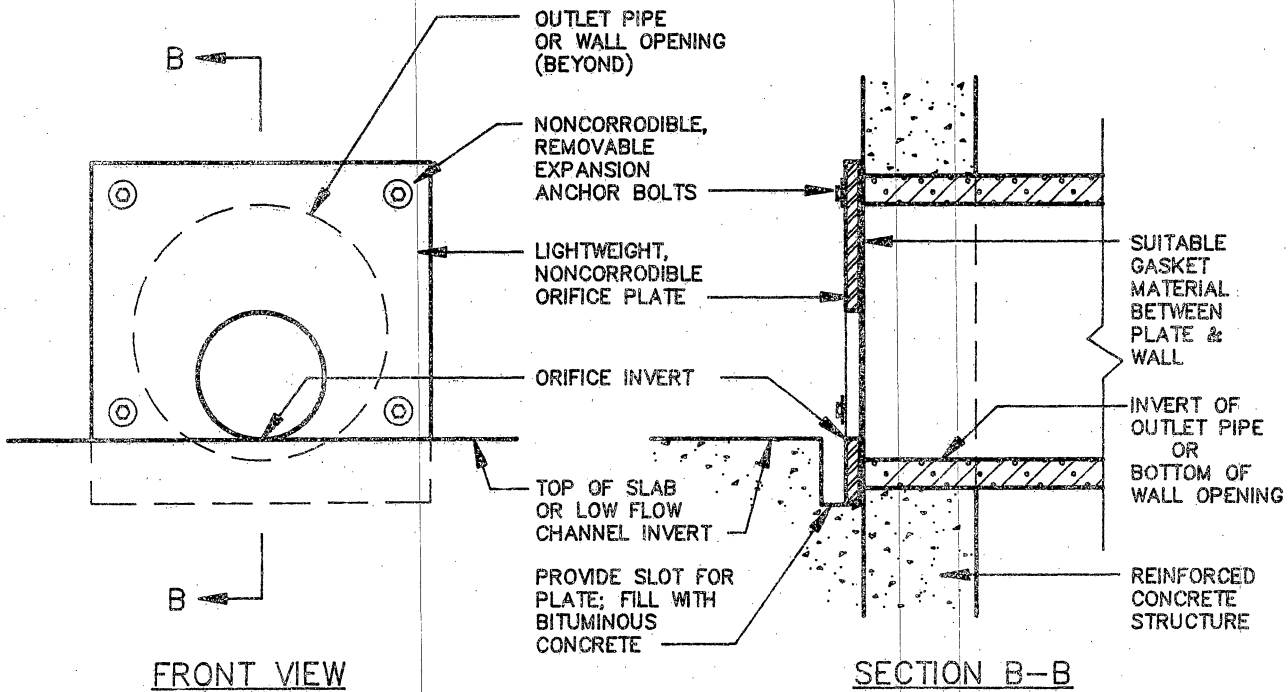

ORIFICE PLATE DETAILS
(NO SCALE)

NJDEP
SWMF MAINTENANCE MANUAL
DETENTION BASIN
ORIFICE AND WEIR PLATES
TYPICAL DETAILS
PLATE 2-A

SEE PARAGRAPH 3 ON PAGE PLAN-15
FOR ADDITIONAL INFORMATION

PLANNING AND DESIGN GUIDELINES
DETENTION FACILITIES

4. To facilitate access and movement by maintenance personnel, principal outlet structures should have a minimum horizontal interior dimension of 4 feet. (See J. ACCESS for additional details.)

5. Vital parts of the principal outlet structure should be readily and safely accessible to maintenance personnel during both normal and emergency conditions. Temporary measures such as ladders are only acceptable for emergency conditions as part of an approved emergency action plan. (See J. ACCESS for additional details.)

6. To minimize both required maintenance and the consequences of inadequate maintenance, principal outlets should avoid utilizing moving parts for outflow control whenever possible.

7. To facilitate cleaning, outlet pipes should have a minimum diameter of 18 inches. The pipes should be constructed of durable materials, such as reinforced concrete.

8. Grading and landscaping around principal outlet structures should be designed to facilitate mowing, trimming, debris removal, and other general maintenance tasks. Grassed slopes which require mowing should not exceed 3 horizontal to 1 vertical. Vegetated cover which does not require mowing or nonvegetated linings should be used where steeper slopes are necessary.

9. Stable areas which provide maintenance personnel with firm footing should be provided at the upstream face of principal outlet structures. Linings such as reinforced concrete, gabions, and grouted riprap should be considered.

10. All nonvegetative linings which are bordered by grass should be designed to permit complete mowing along all edges.

11. Dry weather flow through a principal outlet structure should not interfere with routine interior maintenance tasks. Benching, low flow pipes and channels, drop structures, or similar measures should be utilized to convey low flow into and through the structure.

12. Principal outlet structures should be designed to discourage vandalism and graffiti.

PLANNING AND DESIGN GUIDELINES
DETENTION FACILITIES

D. OUTFLOW SYSTEMS

Typical problems that impede or unnecessarily increase proper maintenance include:

- * Difficult to Clean
- * Excessive Sedimentation
- * Erosion and Scour
- * Displaced Lining

1. The outflow conveyance system downstream of a detention facility should have adequate capacity to accommodate facility outflows. This will not only allow design outflows and water surfaces to be attained, but will also help achieve required drawdown times.

2. Outflow velocities should be high enough to prevent sedimentation and low enough to prevent erosion and scour.

3. Manholes, gates, and other suitable access points should be provided for cleaning and inspection. (See J. ACCESS for additional details.)

E. INLETS

Typical problems that impede or unnecessarily increase proper maintenance include:

- * Difficult to Clean
- * Excessive Sedimentation
- * Erosion and Scour
- * Displaced Lining

1. The number of inlets to a detention facility should be kept to a minimum and placed as close to the principal outlet as possible. This will minimize the amount of required downstream lining and low flow channels. All inflow pipes and culverts should terminate at a headwall or flared end section with adequate cutoff walls.

2. Linings placed downstream of facility inlets should accommodate design flows without erosion or scour. They should also facilitate removal of sediment and debris. Avoid loose stone, riprap, and other irregularly shaped linings which require hand removal of weeds, sediment, and debris. (See A. BOTTOMS for additional details.)

3. Consideration should be given to placing localized sediment and debris traps immediately downstream of facility inlets. (See A. BOTTOMS for additional details.)

4. Provisions to minimize sediment from entering the facility should be considered. Street sweeping, upstream sedimentation basins and offsite soil stabilization measures can

PLANNING AND DESIGN GUIDELINES
DETENTION FACILITIES

significantly reduce the frequency of required sediment removal operations.

5. To facilitate cleaning, inflow pipes should have a minimum diameter of 18 inches. For durability, the pipes should be constructed of reinforced concrete.

6. Grading and landscaping around facility inlets should be designed to facilitate mowing, trimming, debris removal, and other general maintenance tasks. Grassed slopes which require mowing should not exceed 3 horizontal to 1 vertical. Vegetated cover which does not require mowing or non-vegetated linings should be used where steeper slopes are necessary.

7. Stable areas which provide maintenance personnel with firm footing should be provided at facility inlets. Linings such as reinforced concrete, gabions, and grouted riprap should be considered.

8. All nonvegetative linings which are bordered by grass should be designed to permit complete mowing along all edges.

9. Dry weather flow from a facility inlet should not interfere with routine maintenance tasks. Benching, low flow pipes and channels, drop structures, or similar measures should be utilized to convey low flow from the inlet to the principal outlet.

F. EMERGENCY OUTLETS

Typical problems that impede or unnecessarily increase proper maintenance include:

- * Difficult to Clean
- * Excessive Sedimentation
- * Erosion and Scour
- * Displaced Lining

1. Grass and other vegetative cover is encouraged whenever flow velocities and other design constraints permit. Surface and subsurface soil stabilization measures should be utilized to increase allowable flow velocities and to reduce erosion and scour. [Note: Safe passage of emergency overflows must receive first priority and must not be compromised by selection of emergency outlet lining.]

2. Where nonvegetative linings are required (see 1 above), loose stone, riprap, and other irregular linings which require hand removal of weeds and debris should be avoided.

PLANNING AND DESIGN GUIDELINES
DETENTION FACILITIES

3. All nonvegetative linings which are bordered by grass should be designed to permit complete mowing along all edges.

4. See B. DAMS, EMBANKMENTS, AND SIDE SLOPES for information regarding emergency outlet side slopes.

G. LOW FLOW MEASURES

Typical problems that impede or unnecessarily increase proper maintenance include:

- * Erosion and Scour
- * Difficult to Clean or Mow
- * Settlement
- * Excessive Sedimentation

1. To insure thorough drying of the facility bottom, low flow channels should have sufficient capacity to convey the normal, dry weather discharges from the facility inlets to the principal outlet structure without overtopping. The resultant channel size should not be chosen arbitrarily or simply to allow the use of readily available lining materials or construction equipment.

2. Design velocities in low flow channels should be high enough to prevent sedimentation and low enough to prevent erosion of linings.

3. To simplify mowing and minimize trimming, grass lined low flow channels are recommended whenever non-erosive velocities, smooth alignment, and thorough drying between storm events can be achieved. Please note that, in order to prevent sedimentation, grass lined low flow channels will require steeper bottom slopes than those lined with smoother materials such as concrete.

4. Where low flow channels with nonvegetative lining are required, the use of gabions, concrete, grouted riprap, or other durable material with a relatively smooth surface is recommended to facilitate trash and debris removal and simplify mowing and trimming of adjacent grassed areas. Avoid the use of loose stone, riprap, and other materials with irregular surfaces which require hand removal of weeds, trash, and debris.

5. Low flow channel underdrains connected to the principal outlet structure or other downstream discharge point are recommended to promote quick, thorough drying of both the low flow channel and facility bottom. (See PLATE 2-B for additional information.)

- NOTES:**
1. PROVIDE 4" ϕ WEEP HOLES IN CONCRETE CHANNEL 12' O.C. (MAX.) OR EVERY 100 S.F. OF LINING (WHICHEVER IS LESS). WEEP HOLES MUST NOT BE DIRECTLY CONNECTED TO ANY LOW FLOW CHANNEL UNDERDRAIN PIPE. PLACE GEOTEXTILE FILTER FABRIC UNDER WEEP HOLES.
 2. PROVIDE CONSTRUCTION AND EXPANSION JOINTS IN CONCRETE AT REQUIRED INTERVALS.
 3. PROVIDE CUTOFF WALLS AS REQUIRED

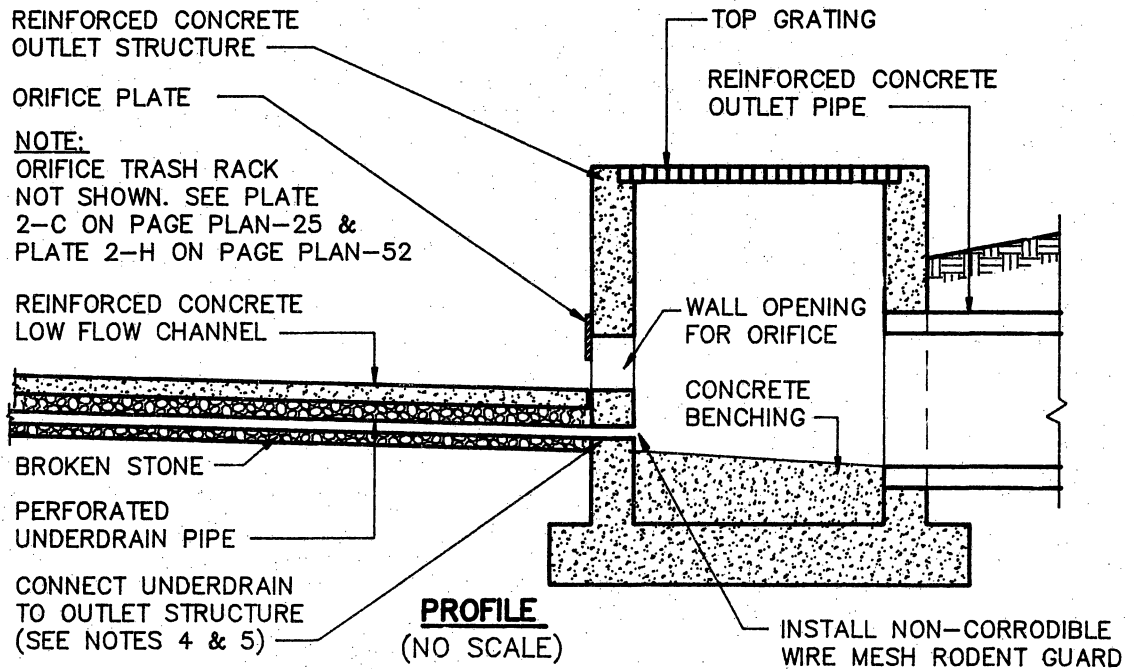
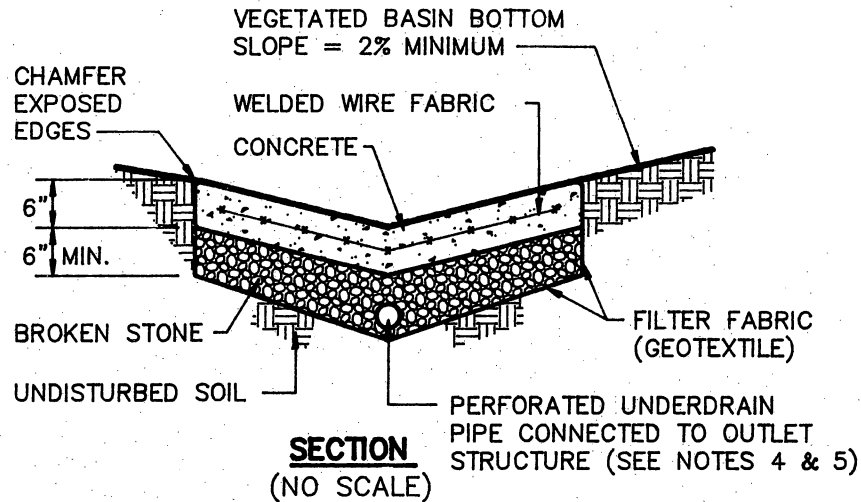

4. FOR GABION LINED LOW FLOW CHANNELS, PROVIDE WEEP HOLES IN UPSTREAM FACE OF OUTLET STRUCTURE AT DOWNSTREAM END OF GABION LINING. GABION LINED CHANNEL CAN THEN SERVE AS ITS OWN UNDERDRAIN.
5. WHERE THE RATE OF FLOW THROUGH THE UNDERDRAIN SYSTEM IS A CONCERN RELATIVE TO THE STORM WATER QUALITY CONTROL, THE UNDERDRAIN SYSTEM SHOULD BE DAYLIGHTED UPSTREAM OF THE CONTROL STRUCTURE.

SEE TEXT FOR ADDITIONAL INFORMATION

NJDEP
SWMF MAINTENANCE MANUAL
LOW FLOW CHANNELS
AND UNDERDRAINS
TYPICAL DETAILS
PLATE 2-B

PLANNING AND DESIGN GUIDELINES
DETENTION FACILITIES

6. To prevent erosion and scour, bank-full velocities in low flow channels lined with nonvegetative lining should not exceed the maximum permissible velocity in adjacent grassed or vegetated areas. If non-erosive velocities cannot be achieved, the lining should be extended into the adjacent areas. When checking the bank-full velocities, the effects of submergence by the principal outlet structure during passage of the bank-full flow should also be considered.

7. To insure thorough drainage of adjacent grassed areas, low flow channels lined with concrete, grouted riprap, and other rigid, impervious material should be designed with the top of the lining at or below the elevation of adjacent grassed areas. This will also assist mowing and trimming. To achieve this, consideration should be given to the potential for settlement of both the impervious lining and adjacent areas and the effects of frost action on the lining. Broken stone foundations and weep holes should be provided for all impervious linings. (See No. 8 below) Consideration should also be given to the potential for erosion or scour along the edges of the lining caused by excessive bank-full velocities (See No. 4 above for additional details). Finally, the required depth of the low flow channel must be remembered when preparing the bottom grading plan.

8. Four inch diameter weep holes should be provided in all rigid, impervious linings. These weep holes should be spaced every 12 feet on center (max.) or one for every 100 square feet of lining, whichever is less. Weep holes must not be directly connected to any low flow channel underdrain pipe. Place geotextile filter fabric under weepholes. (See PLATE 2-B for additional details.)

9. In subsurface facilities, dry weather inflow should not interfere with routine inspection and maintenance. Benching, underdrains, drop inlets, and other measures should be utilized.

H. VEGETATIVE COVER

Typical problems that impede or unnecessarily increase proper maintenance include:

- * Excessive Sedimentation
- * Erosion and Scour
- * Difficult to Mow
- * Poor Growth

1. To minimize maintenance efforts, the use of existing, undisturbed site vegetation is encouraged. To do so, the existing site topography must provide adequate storage volume.

PLANNING AND DESIGN GUIDELINES
DETENTION FACILITIES

2. Where disturbance of existing vegetation cannot be avoided, replacement with low maintenance vegetation with strong resistance to disease and allelopathic (self-weeding) characteristics is encouraged. In general, grass will be easier to establish and will provide better erosion protection than other types of ground cover vegetation. The use of grass varieties that are relatively slow growing and tolerant of poor soil conditions will minimize routine maintenance tasks such as mowing and fertilizing.

The need for supplemental fertilizing can be substantially reduced when the vegetative cover includes a percentage of nitrogen fixing species, such as white clover and other legumes. In addition to minimizing maintenance costs, a reduction in required fertilization will also minimize the potential pollution effects of nitrogen and nitrate runoff.

3. To promote lasting growth, grasses and other vegetative covers should be compatible with the prevailing weather and soil conditions and tolerant of periodic inundation and runoff pollutants.

4. To promote lasting growth, an adequate depth of suitable topsoil should be provided below all vegetative covers. A minimum thickness of 6 inches is recommended.

5. Construction plans and specifications should include requirements for establishing and maintaining all vegetative covers.

6. The effects of sediment removal from vegetated surfaces should be considered in the selection of appropriate cover.

7. Additional information on vegetative covers is available from such agencies as the USDA Soil Conservation Service, local Soil Conservation Districts, the South Jersey Resource Conservation and Development Council, the N.J. Cooperative Extension Service of Rutgers University, and County Cooperative Extension Service offices. Consultation with these agencies during facility planning, design, and review is encouraged.

I. TRASH RACKS

Typical problems that impede or unnecessarily increase proper maintenance include:

- * Difficult to Clean
- * Structural Failure
- * Difficult to Remove
- * Excessive Debris

PLANNING AND DESIGN GUIDELINES
DETENTION FACILITIES

1. Trash racks are intended to prevent trash and debris from blocking a detention facility outlet by intercepting it at an upstream point. Therefore, the need for a trash rack should be based upon the relative sizes and shapes of both the outlet opening and the anticipated debris as well as the consequences of outlet clogging. Special consideration should be given to subsurface facilities.

2. For durability, all trash rack components, including bars, hinges, fasteners, and clamps, should be constructed of lightweight, noncorrodible material such as aluminum. The components should have sufficient design strength to withstand anticipated loads caused by facility outflows, debris, and, where necessary, maintenance personnel.

3. To facilitate cleaning, trash racks should be comprised primarily of sloping bars aligned longitudinally (in the direction of flow). Perpendicular bars, aligned transverse to the direction of flow, should be added for strength and rigidity. These transverse bars should be located below the top face of the longitudinal bars and, if possible, should be round in section. (See PLATE 2-C for additional details.)

4. To minimize the frequency of cleaning, trash rack bars should be spaced close enough to collect debris which may block the outlet orifice or weir but allow passage of smaller debris which will not. In general, longitudinal bars should be spaced a distance equal to $1/3$ the diameter of the outlet orifice or $1/3$ the width of the outlet weir. Minimum and maximum spacings of 1 inch and 6 inches on center, respectively, are recommended. Transverse bars should be spaced as necessary for strength and rigidity. (See PLATE 2-C for additional details.)

5. Trash racks should be hinged or attached with non-corrodible, removable fasteners to allow access to the outlet orifice or weir by maintenance personnel. Lightweight trash racks are easier to lift, repair, and clean behind. (See PLATE 2-C for additional details.)

6. Trash racks should be accessible for cleaning while the facility is dry and, if necessary, at the facility's maximum design water surface elevation. Stable areas of adequate size should be provided around a trash rack to provide firm footing for maintenance personnel and equipment. Concrete pads or other firm surfaces are recommended.

UNHINGED RACKS SHOULD BE MOUNTED ON SUITABLE SEATS EMBEDDED IN WINGWALLS, SEE TOP RACK DETAIL.

HINGES FACILITATE LIFTING AND ACCESS.

ROUND BAR ENDS TO PERMIT RACK TO SWING UP

LONGITUDINAL RACK BARS SHOULD BE RECTANGULAR IN SECTION. RECOMMENDED SPACING = 1/3 ORIFICE DIAMETER. (MINIMUM 1 INCH).

LIGHTWEIGHT NONCORRODIBLE TRASH RACK

SECURE RACK TO WALL OR BOTTOM W/ REMOVABLE, NONCORRODIBLE FASTENERS TO PREVENT UN-AUTHORIZED OPENING

BEVEL BAR ENDS TO MEET BOTTOM SLAB

TRANSVERSE BARS SHOULD BE RECESSED BELOW THE TOP FACE OF TRASH RACK. SPACE BARS AS REQUIRED FOR RACK RIGIDITY AND STRENGTH. CIRCULAR SECTION PREFERRED.

WINGWALL SLOPE GREATER THAN OR EQUAL TO SLOPE OF DAM/EMBANKMENT MAXIMUM SLOPE = 2 HORIZ. : 1 VERT.

TRASH RACK PROTECTS OUTLET ORIFICES. RACK SHOULD BE ACCESSIBLE FROM STRUCTURE TOP

LIGHTWEIGHT, NONCORRODIBLE RACK

METAL ANGLE FORMS RACK SEAT

PROVIDE ANCHORED SEAT FOR RACK. SECURE WITH REMOVABLE, NON-CORRODIBLE FASTENERS. HINGES AND LATCH FACILITATE ACCESS TO STRUCTURE INTERIOR

NONCORRODIBLE REMOVABLE EXPANSION ANCHOR BOLT

ANCHOR IN CONCRETE

TOP OF SLOPE

DAM TOP WIDTH

TOP RACK ENCLOSES OUTLET STRUCTURE, AND PROVIDES OVERFLOW CAPACITY AND INTERIOR ACCESS. BAR SPACING AND STRENGTH SHOULD PROVIDE SAFE FOOTING FOR MAINTENANCE PERSONNEL.

REINFORCED CONCRETE OUTLET STRUCTURE, SEE PLATE 2-B.

**NJDEP
SWMF MAINTENANCE MANUAL**

**DETENTION BASIN
TRASH RACKS
TYPICAL DETAILS**

PLATE 2-C

SEE PARAGRAPHS 3, 4, AND 5 ON PAGE PLAN-24 FOR ADDITIONAL INFORMATION

LOW FLOW CHANNEL

BASIN BOTTOM

UPSTREAM SLOPE OF DAM OR EMBANKMENT

TOE OF SLOPE

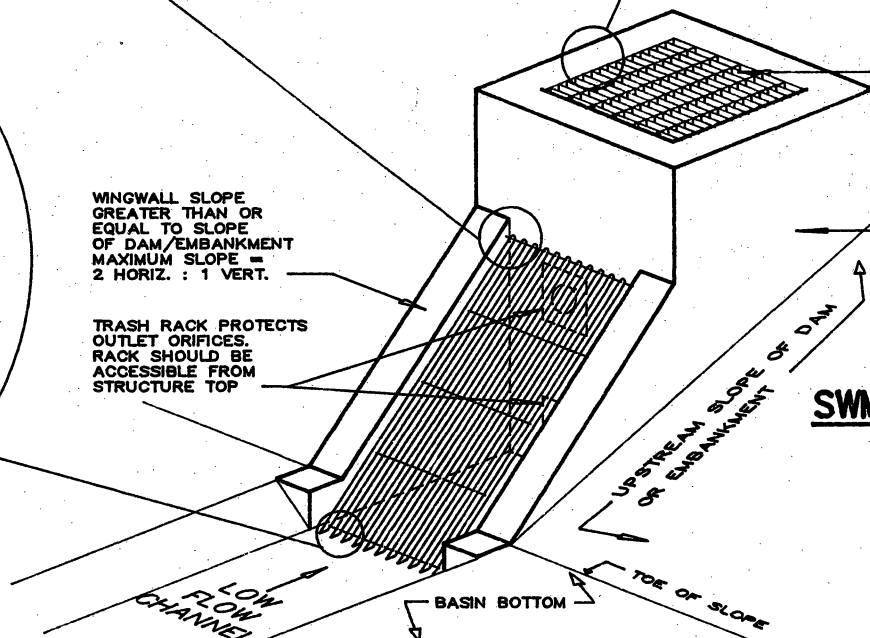

PLANNING AND DESIGN GUIDELINES
DETENTION FACILITIES

J. ACCESS

Typical problems that impede or unnecessarily increase proper maintenance include:

- * Inadequate or Unsafe Access to Facility Components
- * Heavy Gratings and Hatches
- * Corroded Locks
- * Lack of Fence Gates

1. The facility must be readily accessible from a street or other public right-of-way. Inspection and maintenance easements, connected to the street or right-of-way, should be provided around the entire facility. The exact limits of the easements and rights-of-way should be specified on the project plans and other appropriate documents.

2. Field evaluations conducted during the development of this Manual indicate that readily visible detention facilities receive more and better maintenance than those in less visible, more remote locations. This finding should be kept in mind during overall site layout. Readily visible facilities can also be inspected faster and more easily by maintenance and mosquito control personnel.

3. Access roads and gates should be wide enough to allow passage of necessary maintenance vehicles and equipment, including trucks, backhoes, grass mowers, and mosquito control equipment. In general, a minimum right-of-way width of 15 feet and a minimum roadway width of 12 feet is recommended.

4. To facilitate entry, a curb cut should be provided where an access road meets a curbed roadway.

5. To allow safe movement of maintenance vehicles, access ramps should be provided to the bottoms of all detention facilities greater than 5 feet in depth. Access ramps should not exceed 10 per cent in grade.

6. Access roads and ramps should be stable and suitably lined to prevent rutting and other damage by maintenance vehicles and equipment.

7. When backing-up is difficult or dangerous, turnaround areas should be provided at the end of all access roads.

8. To expedite overall maintenance efforts, vehicle and equipment staging areas should be provided at or near each facility site.

PLANNING AND DESIGN GUIDELINES
DETENTION FACILITIES

9. A suitable number of gates should be provided in all fences. The gates should be wide enough to allow passage of necessary equipment and personnel. They should be appropriately located so that they can be fully opened without interference by trees, parked cars, existing or proposed grades, or other obstructions. If it is necessary to lock a gate, it should be done with a noncorrodible chain and padlock. This will permit the installation of additional padlocks on the chain (each padlock becomes a link in the chain), thereby allowing authorized access through the gate by more than one person without the need for multiple keys.

10. Safe, suitable access for maintenance personnel and equipment should be provided to the exterior of each facility component. In doing so, avoid remote component locations, steep slopes, unstable surfaces and linings, and narrow walkways.

11. Suitable access should be provided along both sides of a fence for mowing, trimming, and fence repair.

12. Safe, suitable access for maintenance personnel and equipment should be provided to the interior of the principal outlet. In doing so, avoid heavy hatches, gratings, and other covers. Railings, grab rails, slip-resistant steps, low flow channels, benchings, and hinged, lightweight access covers greatly facilitate interior maintenance. Sufficient interior space should also be provided. A minimum horizontal dimension of 4 feet is recommended.

13. At subsurface detention facilities, suitable access, observation points, and monitoring wells should be provided to allow inspection and cleaning. Access should be provided to all major facility components, particularly at inlets and the principal and emergency outlets, and wherever sediment deposits are expected. This will permit sediment and debris removal through high pressure water spray and vacuum (e.g., Jet-Vac). All access points should be at safe locations on the surface which can be readily accessed, safely barricaded, and clearly identified.

K. PERIMETERS

Typical problems that impede or unnecessarily increase proper maintenance include:

- * Difficult to Mow or Clean
- * Inadequate Size
- * Too Close to Adjacent Structures

1. Field evaluations conducted during the development of this Manual indicate that readily visible detention facil-

PLANNING AND DESIGN GUIDELINES
DETENTION FACILITIES

ities receive more and better maintenance than those in less visible, more remote locations. This finding should be kept in mind during overall site layout. Readily visible facilities can also be inspected faster and more easily by maintenance and mosquito control personnel.

2. Fences, when required for safety or other purposes, should be located to minimize interference with grass mowing and trimming. Suitable access should be provided along both sides.

3. To allow safe movement of maintenance personnel and equipment, fences should be located at least 3 feet beyond the top and toe of any slope steeper than 5 horizontal to 1 vertical.

4. Fences should be constructed of durable, vandal-resistant materials. Fences must meet all local code requirements.

5. To minimize the amount of required trimming, fences in grassed areas should be installed, whenever practical, with a bottom rail set high enough above finished grade to allow mowing beneath it.

6. Grassed areas beyond the tops of detention facilities should have a minimum slope of 2 per cent to promote effective surface drainage and thorough drying.

7. Perimeters should be planned and designed to discourage vandalism and dumping of trash and debris.

8. Facility perimeters should be large enough to allow movement and operation of maintenance and mosquito control equipment. A minimum perimeter width of 25 feet between the facility and adjacent structures is recommended along at least one side of the facility. This portion of the perimeter should be readily accessible from a street or other public right-of-way.

**PLANNING AND DESIGN GUIDELINES
FOR
STORMWATER INFILTRATION FACILITIES**

OVERVIEW

The following Planning and Design Guidelines are intended to assist in the creation of stormwater infiltration facilities that require the least practical level of maintenance. To accomplish this, they have been developed to (1) eliminate avoidable maintenance tasks, (2) minimize the long term amount of regular maintenance, (3) facilitate the performance of required maintenance tasks, and (4) reduce the potential for extensive, difficult, and costly remedial or emergency maintenance efforts.

As such, the guidelines presented herein are intended to supplement all other applicable infiltration facility standards, including those pertaining to hydrologic, hydraulic, structural, environmental, legal, and aesthetic aspects. They should also be used creatively in conjunction with all other applicable standards to create stormwater infiltration facilities that require minimum levels of maintenance performed with the least possible effort, time, and cost.

To assist in their use, the Planning and Design Standards are presented by infiltration facility component in the following order:

- | | |
|--|-----------------------------|
| A. Bottoms | D. Emergency Outlets |
| B. Dams, Embankments, and
Side Slopes | E. Vegetative Cover |
| C. Inlets | F. Access |
| | G. Perimeters |

Detailed descriptions of each facility component listed above are presented in Table 2-1 on Page Plan-10.

At the beginning of each component section presented below is a list of common maintenance problems that the guidelines which follow have been developed to prevent. These problems, which have been identified through surveys, interviews, and site inspections, are intended to enhance the effectiveness of the guidelines by illustrating the guidelines' origins and purpose. They should also serve to stimulate the development of additional guidelines by infiltration facility planners, designers, and reviewers. More detailed information regarding infiltration facility maintenance problems and their causes can be found in the NJDEP's Ocean County Demonstration Study Report. Additional information regarding infiltration facility planning and design is published in the NJDEP's A Guide to Stormwater Management Practices in New Jersey.

PLANNING AND DESIGN GUIDELINES
INFILTRATION FACILITIES

A. BOTTOMS

Typical problems that impede or unnecessarily increase proper maintenance include:

- * Standing Water
- * Soggy Surfaces
- * Poor Grass Growth
- * Excessive Sedimentation
- * Limited Access

1. The infiltration rate of the soil will determine a site's suitability as an infiltration facility. In general, infiltration facilities should only be constructed in areas of Hydrologic Soil Group A or B as defined by the USDA Soil Conservation Service. Borings should be taken at the facility site to ascertain the characteristics of both the surface and subsurface soils. In no case should an infiltration facility be constructed if the infiltration rate of the soil is less than 0.52 inches per hour.

2. To provide adequate drying time, to avoid delaying scheduled maintenance efforts, and to prevent mosquito breeding, the maximum storage or ponding duration should not exceed 48 hours.

3. To promote complete infiltration and prevent standing water or soggy surfaces, the lowest point in the bottom of the facility should be at least 4 feet above the seasonally high groundwater level or bedrock. Subsurface drains may be utilized to lower groundwater levels and/or promote complete infiltration. (See No. 4 below.)

4. To promote complete infiltration and prevent standing water or soggy surfaces, vegetated bottoms should have a minimum slope of 1 percent and be graded to a stone filled trench. This trench should be located at the lowest point in the bottom and extend to all inlet points. Gabions are recommended for use in constructing the trench. The elevation of the trench bottom should be at least 4 feet above the seasonally high groundwater level or bedrock. (See PLATE 2-D for additional information.)

5. To avoid delaying scheduled maintenance efforts, topsoils should be sufficiently permeable to allow rapid evaporation and drying.

6. In order to prevent sloughing caused by seepage of infiltrated water, an infiltration facility should not be located on or near a steep slope. In general, a facility should not be constructed where nearby slopes exceed 20 percent.

7. Sediment from construction operations can quickly clog soil pores of an infiltration facility, often necessitating

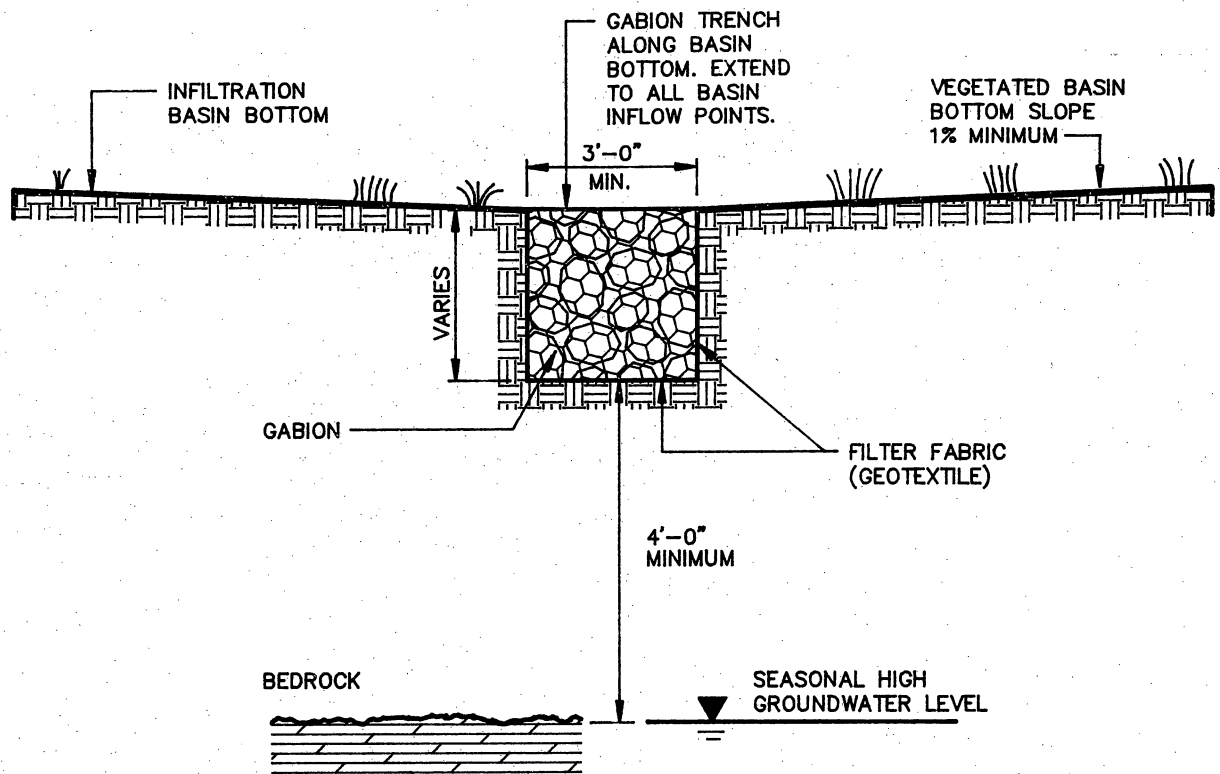

NO SCALE

NOTE: GABION BASKETS ARE RECOMMENDED OVER LOOSE STONE TO PROVIDE SMOOTH TOP SURFACE WHICH WILL FACILITATE MOWING OF BASIN BOTTOM AND TO PREVENT UNAUTHORIZED REMOVAL AND OTHER VANDALISM.

**NJDEP
SWMF MAINTENANCE MANUAL**

**INFILTRATION BASIN
UNDERDRAINS
TYPICAL DETAILS**

PLATE 2-D

SEE PARAGRAPH 4 ON PAGE PLAN-30
FOR ADDITIONAL INFORMATION

PLANNING AND DESIGN GUIDELINES
INFILTRATION FACILITIES

expensive maintenance work even before the facility is placed into normal operation. Therefore, an infiltration facility should not be used for sediment control purposes during construction and, consequently, should not be constructed until the upstream drainage area is fully developed and adequately stabilized. If that is not feasible, the facility should only be partially excavated until all disturbed areas have been stabilized or protected. Thereafter, final excavation to finished grade should also include removal of all deposited sediment. Under no circumstances should a subsurface infiltration facility (e.g., drywell, seepage pit, infiltration trench, etc.) be used for sediment control during construction.

8. During construction, heavy equipment should not be allowed on the facility bottom. Compaction of the natural subgrade can seriously impair the infiltration rate.

9. As an alternative to vegetative cover, a 12" layer of filter material, such as coarse sand, may be considered in the facility bottom. This layer of material can be cleaned of sediment or replaced as necessary. Prior to the selection of this alternative material, such factors as aesthetics, weed growth, and movement of maintenance personnel and equipment about the bottom must be considered. (See PLATE 2-E for additional information.)

10. To minimize routine grass maintenance such as mowing and fertilizing, the use of grass varieties that are relatively slow growing and tolerant of poor soil conditions are encouraged. Information on these and other grass varieties and mixtures are available from local Soil Conservation Districts. (See E. VEGETATIVE COVER for additional details.)

11. To promote lasting growth, grasses and other vegetative covers should be compatible with the prevailing weather and soil conditions and tolerant of periodic inundation and harmful runoff pollutants. (See E. VEGETATIVE COVER for additional details.)

12. To facilitate removal efforts, sedimentation should be promoted at localized, readily accessible areas. The use of sediment traps at inflow points is encouraged, especially those lined with materials which have smooth, easily cleaned surfaces such as concrete. For this reason, the use of loose stone, riprap, and other irregular linings which require manual removal of weeds, sediment, and debris should be avoided.

13. Suitable access for maintenance personnel and equipment should be provided. (See F. ACCESS For details.)

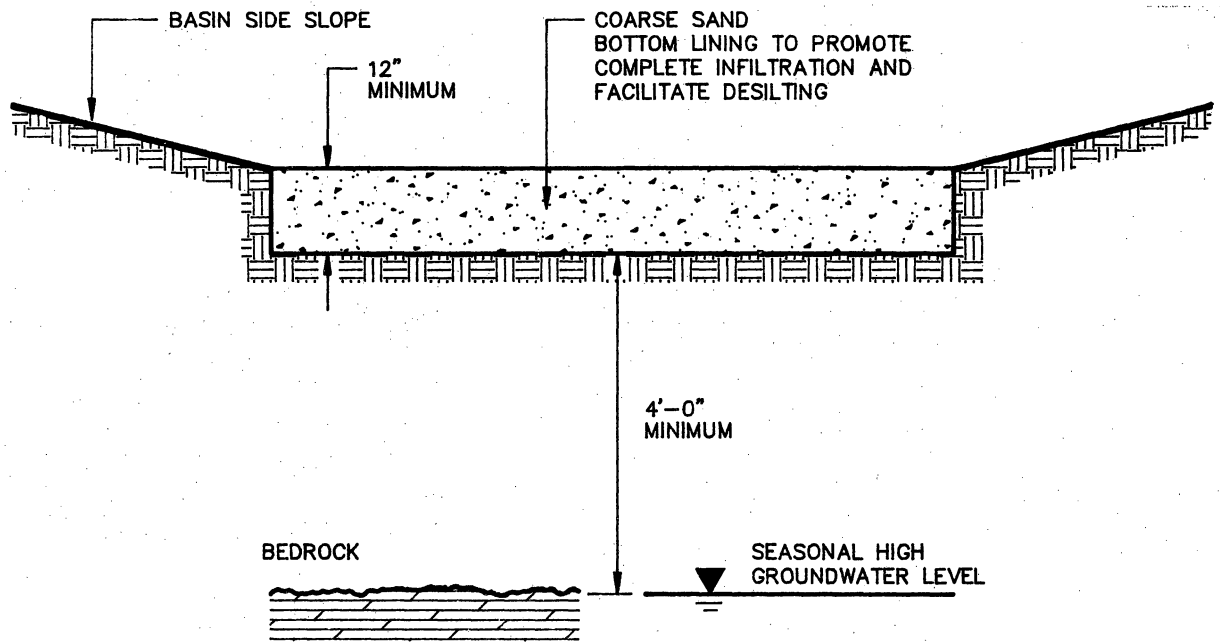

NO SCALE

NJDEP
SWMF MAINTENANCE MANUAL
NONVEGETATED INFILTRATION
BASIN BOTTOMS
TYPICAL DETAILS
PLATE 2-E

SEE PARAGRAPH 9 ON PAGE PLAN-32
 FOR ADDITIONAL INFORMATION

PLANNING AND DESIGN GUIDELINES
INFILTRATION FACILITIES

14. All nonvegetative linings which are bordered by grass should be designed to permit complete mowing along all edges.

15. Temporary emergency measures such as pumps should be provided to drain standing water from malfunctioning infiltration facilities.

16. If feasible, alternative outlet measures should be designed to permanently convert an infiltration facility to a detention facility if necessary due to loss of infiltration capacity. If practical, these alternative outlet measures should be included in the facility's original construction.

17. At subsurface infiltration facilities, suitable access, observation points, and/or monitoring wells should be provided to facilitate inspection and cleaning. (See F. ACCESS for additional details.)

B. DAMS, EMBANKMENTS, AND SIDE SLOPES

Typical problems that impede or unnecessarily increase proper maintenance include:

- * Steep Slopes
- * Long Slopes
- * Poor Grass Growth
- * Sloughing and Erosion

1. For safe movement of personnel and safe operation of equipment, side slopes greater than 5 feet in height should not be steeper than 4 horizontal to 1 vertical. Side slopes less than 5 feet high should not exceed 3 horizontal to 1 vertical. Flatter side slopes are recommended wherever possible.

2. For safe movement of personnel and safe operation of equipment, side slopes steeper than 5 to 1 and higher than 15 feet should be terraced at their midpoints. The terrace should have a minimum width of 3 feet and should be graded at 2 per cent towards the lower half of the slope.

3. Suitable access to and along side slopes should be provided for maintenance personnel and equipment. (See F. ACCESS for details.)

4. Topsoil and vegetative covers must be protected from erosion caused by local runoff and the slope's steepness. Surface and subsurface soil stabilization measures or non-vegetated linings should be utilized as necessary. In doing so, avoid the use of loose stones, riprap, and other irregular lining materials which require hand removal of weeds and debris and may be a hazard to maintenance personnel.

PLANNING AND DESIGN GUIDELINES
INFILTRATION FACILITIES

5. All nonvegetative linings which are bordered by grass should be designed to permit complete mowing along all edges.

6. The effects of rapid pool drawdown should be checked to prevent sloughing.

7. For safe movement of personnel and safe operation of equipment, fences should not be constructed within 3 feet of either the top or toe of any side slope that exceeds 5 horizontal to 1 vertical.

C. INLETS

Typical problems that impede or unnecessarily increase proper maintenance include:

- * Difficult to Clean
- * Excessive Sedimentation
- * Erosion and Scour
- * Displaced Lining

1. All inflow pipes and culverts should terminate at a head-wall or flared end section with adequate cutoff walls.

2. Linings placed downstream of facility inlets should accommodate design flows without erosion or scour. They should also facilitate removal of sediment and debris. Avoid loose stone, riprap, and other irregularly shaped linings which require hand removal of weeds, sediment, and debris. (See A. BOTTOMS for additional details.)

3. Consideration should be given to placing localized sediment and debris traps immediately downstream of facility inlets. (See A. BOTTOMS for additional details.)

4. Provisions to minimize sediment from entering the facility should be considered. Street sweeping, upstream sedimentation basins and offsite soil stabilization measures can significantly reduce the frequency of required sediment removal operations.

5. To facilitate cleaning, inflow pipes should have a minimum diameter of 18 inches. The pipes should be constructed of durable materials, such as reinforced concrete.

6. Grading and landscaping around facility inlets should be designed to facilitate mowing, trimming, debris removal, and other general maintenance tasks. Grassed slopes which require mowing should not exceed 3 horizontal to 1 vertical. Vegetated cover which does not require mowing or non-

PLANNING AND DESIGN GUIDELINES
INFILTRATION FACILITIES

vegetated linings should be used where steeper slopes are necessary.

7. Stable areas which provide maintenance personnel with firm footing should be provided at facility inlets. Linings such as reinforced concrete, gabions, and grouted riprap should be considered.

8. All nonvegetative linings which are bordered by grass should be designed to permit complete mowing along all edges.

D. EMERGENCY OUTLETS

Typical problems that impede or unnecessarily increase proper maintenance include:

- * Difficult to Clean
- * Excessive Sedimentation
- * Erosion and Scour
- * Displaced Lining

1. Grass and other vegetative cover is encouraged whenever flow velocities and other design constraints permit. Surface and subsurface soil stabilization measures should be utilized to increase allowable flow velocities and to reduce erosion and scour. [Note: Safe passage of emergency overflows must receive first priority and must not be compromised by selection of emergency outlet lining.]

2. Where nonvegetative linings are required (see 1 above), loose stone, riprap, and other irregular linings which require hand removal of weeds and debris should be avoided.

3. All nonvegetative linings which are bordered by grass should be designed to permit complete mowing along all edges.

4. See B. DAMS, EMBANKMENTS, AND SIDE SLOPES for information regarding emergency outlet side slopes.

E. VEGETATIVE COVER

Typical problems that impede or unnecessarily increase proper maintenance include:

- * Excessive Sedimentation
- * Difficult to Mow
- * Erosion and Scour
- * Poor Growth

PLANNING AND DESIGN GUIDELINES
INFILTRATION FACILITIES

1. To minimize maintenance efforts, the use of existing, undisturbed site vegetation is encouraged. To do so, the existing site topography must provide adequate storage volume.

2. Where disturbance of existing vegetation cannot be avoided, replacement with low maintenance vegetation with strong resistance to disease and allelopathic (self-weeding) characteristics is encouraged. In general, grass will be easier to establish and will provide better erosion protection than other types of ground cover vegetation. The use of grass varieties that are relatively slow growing and tolerant of poor soil conditions will minimize routine maintenance tasks such as mowing and fertilizing.

The need for supplemental fertilizing can be substantially reduced when the vegetative cover includes a percentage of nitrogen fixing species, such as white clover and other legumes. In addition to minimizing maintenance costs, a reduction in required fertilization will also minimize the potential pollution effects of nitrogen and nitrate runoff.

3. To promote lasting growth, grasses and other vegetative covers should be compatible with the prevailing weather and soil conditions and tolerant of periodic inundation and runoff pollutants.

4. To promote lasting growth, an adequate depth of suitable topsoil should be provided below all vegetative covers. A minimum thickness of 6 inches is recommended. The effects of this topsoil on the basin's ability to infiltrate storm-water runoff must be considered in the basin's design.

5. Construction plans and specifications should include requirements for establishing and maintaining all vegetative covers.

6. The effects of sediment removal from vegetated surfaces should be considered in the selection of appropriate cover.

7. Additional information on vegetative covers is available from the USDA Soil Conservation Service, local Soil Conservation Districts, the South Jersey Resource Conservation and Development Council, the N.J. Cooperative Extension Service of Rutgers University, and County Cooperative Extension Service offices. Consultation with these agencies during facility planning, design, and review is encouraged.

PLANNING AND DESIGN GUIDELINES
INFILTRATION FACILITIES

F. ACCESS

Typical problems that impede or unnecessarily increase proper maintenance include:

- * Inadequate or Unsafe Access to Facility Components
- * Corroded Locks
- * Lack of Fence Gates

1. The facility must be readily accessible from a street or other public right-of-way. Inspection and maintenance easements, connected to the street or right-of-way, should be provided around the entire facility. The exact limits of the easements and rights-of-way should be specified on the project plans and other appropriate documents.

2. Field evaluations conducted during the development of this Manual indicate that readily visible facilities receive more and better maintenance than those in less visible, more remote locations. This finding should be kept in mind during overall site layout. Readily visible facilities can also be inspected faster and more easily by maintenance and mosquito control personnel.

3. Access roads and gates should be wide enough to allow passage of necessary maintenance vehicles and equipment, including trucks, backhoes, grass mowers, and mosquito control equipment. In general, a minimum right-of-way width of 15 feet and a minimum roadway width of 12 feet is recommended.

4. To facilitate entry, a curb cut should be provided where an access road meets a curbed roadway.

5. To allow safe movement of maintenance vehicles, access ramps should be provided to the bottoms of all infiltration facilities greater than 5 feet in depth. All access ramps should not exceed 10 per cent in grade.

6. Access roads and ramps should be stable and suitably lined to prevent rutting and other damage by maintenance vehicles and equipment.

7. When backing-up is difficult or dangerous, turnaround areas should be provided at the end of all access roads.

8. To expedite overall maintenance efforts, vehicle and equipment staging areas should be provided at or near each facility site.

9. A suitable number of gates should be provided in all fences. The gates should be wide enough to allow passage of necessary equipment and personnel. They should be ap-

PLANNING AND DESIGN GUIDELINES
INFILTRATION FACILITIES

appropriately located so that they can be fully opened without interference by trees, parked cars, existing or proposed grades, or other obstructions. If it is necessary to lock a gate, it should be done with a noncorrodible chain and padlock. This will permit the installation of additional padlocks on the chain (each padlock becomes a link in the chain), thereby allowing authorized access through the gate by more than one person without the need for multiple keys.

10. Safe, suitable access for maintenance personnel and equipment should be provided to the exterior of each facility component. In doing so, avoid remote component locations, steep slopes, unstable surfaces and linings, and narrow walkways.

11. Suitable access should be provided along both sides of a fence for mowing, trimming, and fence repair.

12. At subsurface infiltration facilities, suitable access, observation points, and/or monitoring wells should be provided to allow inspection and cleaning. These access points should be provided at opposite ends of the facility to permit sediment removal by high pressure water spray and vacuum (e.g., Jet-Vac). All access points should be at safe locations on the surface which can be readily accessed, safely barricaded, and clearly identified.

G. PERIMETERS

Typical problems that impede or unnecessarily increase proper maintenance include:

- * Difficult to Mow or Clean
- * Inadequate Size
- * Too Close to Adjacent Structures

1. Field evaluations conducted during the development of this Manual indicate that readily visible facilities receive more and better maintenance than those in less visible, more remote locations. This finding should be kept in mind during overall site layout. Readily visible facilities can also be inspected faster and more easily by maintenance and mosquito control personnel.

2. Fences, when required for safety or other purposes, should be located to minimize interference with grass mowing and trimming. Suitable access should be provided along both sides.

PLANNING AND DESIGN GUIDELINES
INFILTRATION FACILITIES

3. To allow safe movement of maintenance personnel and equipment, fences should be located at least 3 feet beyond either the top or toe of any slope steeper than 5 horizontal to 1 vertical.

4. Fences should be constructed of durable, vandal-resistant materials. Fences must meet all local code requirements.

5. To minimize the amount of required trimming, fences in grassed areas should be installed, whenever practical, with a bottom rail set high enough above finished grade to allow mowing beneath it.

6. Grassed areas beyond the tops of infiltration facilities should have a minimum slope of 2 per cent to promote effective surface drainage and thorough drying.

7. Perimeters should be planned and designed to discourage vandalism and dumping of trash and debris.

8. Facility perimeters should be large enough to allow movement and operation of maintenance and mosquito control equipment. A minimum perimeter width of 25 feet between the facility and adjacent structures is recommended along at least one side of the facility. This portion of the perimeter should be readily accessible from a street or other public right-of-way.

**PLANNING AND DESIGN GUIDELINES
FOR
STORMWATER RETENTION FACILITIES**

OVERVIEW

The following Planning and Design Guidelines are intended to assist in the creation of stormwater retention facilities that require the least practical level of maintenance. To accomplish this, they have been developed to (1) eliminate avoidable maintenance tasks, (2) minimize the long term amount of regular maintenance, (3) facilitate the performance of required maintenance tasks, and (4) reduce the potential for extensive, difficult, and costly remedial or emergency maintenance efforts.

As such, the guidelines presented herein are intended to supplement all other applicable retention facility standards, including those pertaining to hydrologic, hydraulic, structural, environmental, legal, and aesthetic aspects. They should also be used creatively in conjunction with all other applicable standards to create stormwater retention facilities that require minimum levels of maintenance performed with the least possible effort, time, and cost.

To assist in their use, the Planning and Design Guidelines are presented by retention facility component in the following order:

- | | |
|--|----------------------|
| A. Bottoms and Permanent Pools | F. Emergency Outlets |
| B. Dams, Embankments, and
Side Slopes | G. Vegetative Cover |
| C. Principal Outlets | H. Trash Racks |
| D. Outflow Systems | I. Access |
| E. Inlets | J. Perimeters |

Detailed descriptions of each facility component listed above are presented in Table 2-1 on Page Plan-10.

At the beginning of each component section presented below is a list of common maintenance problems that the guidelines which follow have been developed to prevent. These problems, which have been identified through surveys, interviews, and site inspections, are intended to enhance the effectiveness of the guidelines by illustrating the guidelines' origins and purpose. They should also serve to stimulate the development of additional guidelines by retention facility planners, designers, and reviewers. More detailed information regarding retention facility maintenance problems and their causes can be found in the NJDEP's **Ocean County Demonstration Study Report**. Additional information regarding retention facility planning and design is published in the NJDEP's **A Guide to Stormwater Management Practices in New Jersey**.

PLANNING AND DESIGN GUIDELINES
RETENTION FACILITIES

A. BOTTOMS AND PERMANENT POOLS

Typical problems that impede or unnecessarily increase proper maintenance include:

- * Poor Water Quality
- * Limited Access
- * Non-Permanent Pool
- * Excessive Sedimentation

1. In order to promote a healthy aquatic ecosystem, the minimum permanent pool depth should be 4 feet.

2. Design of a retention facility should include the determination of the proposed site's ability to adequately support a viable permanent pool. The design should account for such factors as the required rate and quality of dry weather inflow, the quality of stormwater inflow, seasonal and longer term variations in the groundwater table, and the effects of expected sediment loading. The Division of Fish, Game, and Wildlife of the N.J. Department of Environmental Protection should be consulted during the facility's design for information regarding the establishment of a suitable habitat for fish and other aquatic life. Predacious fish species can be particularly helpful in controlling mosquito breeding.

3. Provisions to drain the permanent pool are necessary for maintenance and safety. A gravity drain is the preferred means of accomplishing this. If a gravity drain is not feasible, suitable pumps and both primary and backup power sources should be provided.

4. To promote complete emptying when necessary, the bottom of the basin should be sloped toward the outlet drain at a minimum slope of 2 per cent.

5. Water quality, including suitable oxygen levels, should be maintained through continuous recharge with fresh water from either surface or subsurface sources. Where adequate oxygen levels cannot be assured through inflow, mechanical aeration should be provided.

6. To facilitate removal efforts, sedimentation should be promoted at localized, readily accessible areas. The use of sediment traps at inflow points is encouraged.

7. Suitable access for maintenance personnel and equipment should be provided. (See I. ACCESS For details.)

PLANNING AND DESIGN GUIDELINES
RETENTION FACILITIES

B. DAMS, EMBANKMENTS, AND SIDE SLOPES

Typical problems that impede or unnecessarily increase proper maintenance include:

- * Steep Slopes
- * Long Slopes
- * Poor Grass Growth
- * Sloughing and Erosion
- * Shoreline Deterioration

1. For shoreline protection and to facilitate grass mowing, a suitable non-erosive lining such as gabions should be placed along the edge of the permanent pool. The lining should extend sufficiently above and below the permanent pool elevation to account for wave heights and run-up. (See PLATE 2-F for additional information.)

2. Below the permanent pool level, a 4' to 6' wide level area should be provided to prevent people or objects from sliding into deeper water. The side slope from this level area to the bottom of the pool should be at a slope that will remain stable, usually no steeper than 2 horizontal to 1 vertical. (See PLATE 2-F for additional information.)

3. Side slopes greater than 5 feet in height should not be steeper than 4 horizontal to 1 vertical, for safe movement of personnel and safe operation of equipment. Side slopes less than 5 feet high should not exceed 3 horizontal to 1 vertical. Flatter side slopes are recommended wherever possible.

4. For safe movement of personnel and safe operation of equipment, side slopes steeper than 5 to 1 and higher than 15 feet should be terraced at their midpoints. The terrace should have a minimum width of 3 feet and should be graded at 2 per cent towards the lower half of the slope.

5. Suitable access to and along side slopes should be provided for maintenance personnel and equipment. (See I. ACCESS for details.)

6. Topsoil and vegetative covers must be protected from erosion caused by local runoff and the slope's steepness. Surface and subsurface soil stabilization measures or non-vegetated linings should be utilized as necessary. In doing so, avoid the use of loose stones, riprap, and other irregular lining materials which require hand removal of weeds and debris and may be a safety hazard to maintenance personnel.

7. All nonvegetative linings which are bordered by grass should be designed to permit complete mowing along all edges.

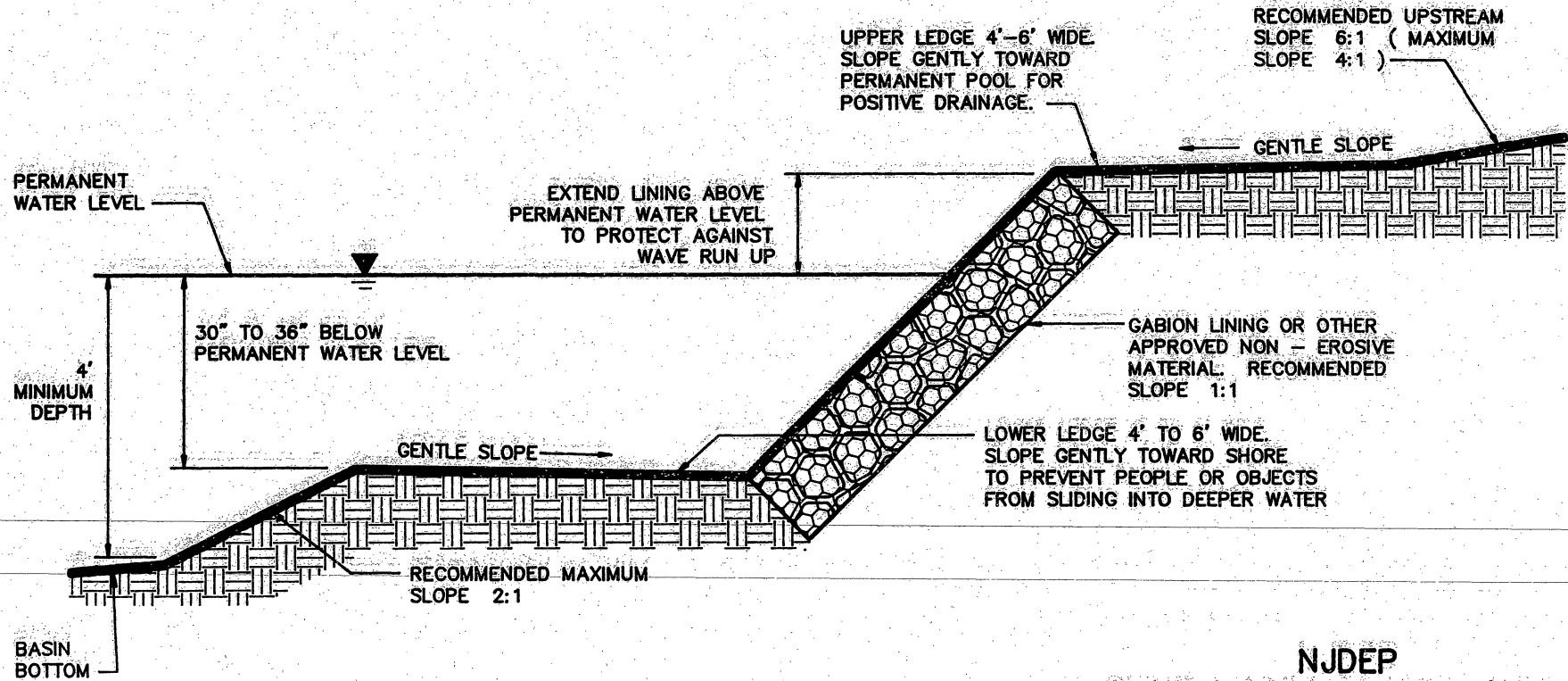

NO SCALE

**NJDEP
SWMF MAINTENANCE MANUAL
RETENTION BASIN
SIDE SLOPES
TYPICAL DETAILS
PLATE 2-F**

SEE PARAGRAPHS 1 AND 2 ON PAGE PLAN-43
FOR ADDITIONAL INFORMATION

PLANNING AND DESIGN GUIDELINES
RETENTION FACILITIES

8. To provide adequate drying time, to avoid delaying scheduled maintenance efforts, and to prevent mosquito breeding, the maximum storage or ponding duration above the permanent pool should not exceed 48 hours.

9. The effects of rapid pool drawdown should be checked to prevent sloughing of the side slopes.

10. For safe movement of personnel and safe operation of equipment, fences should not be constructed within 3 feet of either the top or toe of any side slope that exceeds 5 horizontal to 1 vertical.

C. PRINCIPAL OUTLETS

Typical problems that impede or unnecessarily increase proper maintenance include:

- * Structural Deterioration
- * Limited Access
- * Corroded Appurtenances
- * Vandalism
- * Excessive Debris Accumulation

1. For durability, principal outlet structures should be constructed of reinforced concrete containing Type II cement and having a specified 28-day compressive strength of 3,000 PSI. Concrete shall be designed in accordance with all applicable codes and requirements, including the current edition of Building Code Requirements for Building Construction (ACI 318) of the American Concrete Institute.

2. For durability, all appurtenances, including access hatches, trash racks, gratings, railings, orifice and weir plates, and fasteners should be constructed of lightweight, noncorrodible materials. Material strengths should be sufficient to withstand design loads without damage or failure.

3. Outlet orifice and weir plates should be constructed from aluminum or other lightweight, noncorrodible material. The plates should be fastened to the structure with noncorrodible, removable fasteners. A gasket of neoprene or similar material should be placed between the plate and the structure wall. The opening in the structure wall over which the plate is bolted should have at least twice the area of the outlet orifice or weir to facilitate future expansion. (See PLATE 2-G for additional information.)

4. To facilitate access and movement by maintenance personnel, principal outlet structures should have a minimum horizontal interior dimension of 4 feet. (See I. ACCESS for additional details.)

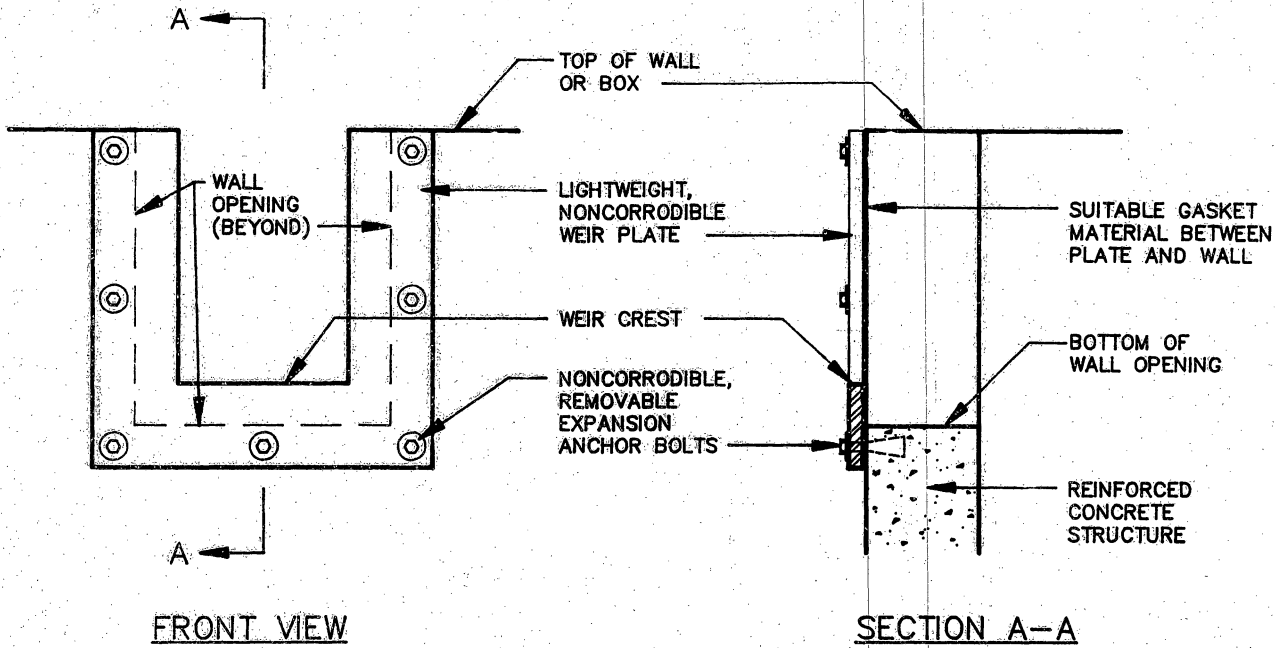

WEIR PLATE DETAILS
(NO SCALE)

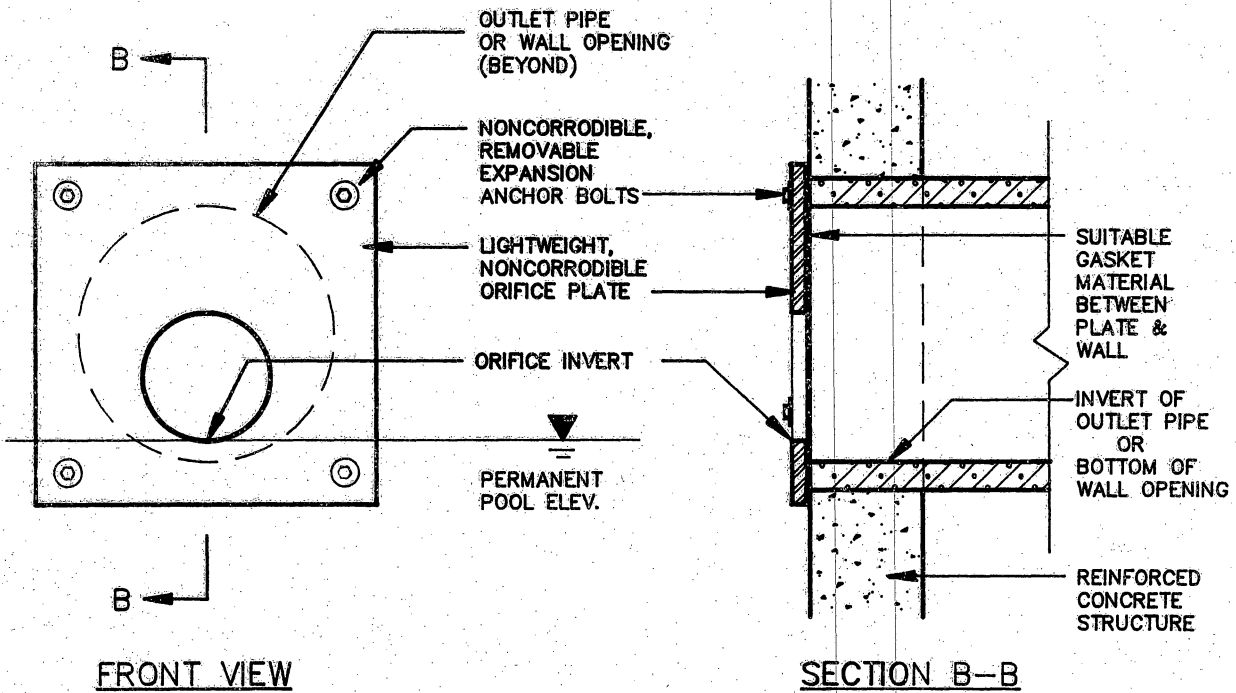

ORIFICE PLATE DETAILS
(NO SCALE)

NJDEP
SWMF MAINTENANCE MANUAL
RETENTION BASIN
ORIFICE AND WEIR PLATES
TYPICAL DETAILS
PLATE 2-G

SEE PARAGRAPH 3 ON PAGE PLAN-45
FOR ADDITIONAL INFORMATION

**PLANNING AND DESIGN GUIDELINES
RETENTION FACILITIES**

5. Vital parts of the principal outlet structure should be readily and safely accessible to maintenance personnel during both normal and emergency conditions. Temporary measures such as ladders are only acceptable for emergency conditions as part of an approved emergency action plan. (See I. ACCESS for additional details.)

6. To minimize both required maintenance and the consequences of inadequate maintenance, principal outlets should avoid utilizing moving parts for outflow control above the permanent pool elevation whenever possible.

7. To facilitate cleaning, outlet pipes should have a minimum diameter of 18 inches. The pipes should be constructed of durable materials, such as reinforced concrete.

8. Grading and landscaping around principal outlet structures should be designed to facilitate mowing, trimming, debris removal, and other general maintenance tasks. Grassed slopes which require mowing should not exceed 3 horizontal to 1 vertical. Vegetated cover which does not require mowing or nonvegetated linings should be used where steeper slopes are necessary.

9. All nonvegetative linings which are bordered by grass should be designed to permit complete mowing along all edges.

10. Dry weather flow through a principal outlet structure should not interfere with routine interior maintenance tasks. Benching, low flow pipes and channels, drop structures, or similar measures should be utilized to convey low flow into and through the structure.

11. Principal outlet structures should be designed to discourage vandalism and graffiti.

D. OUTFLOW SYSTEMS

Typical problems that impede or unnecessarily increase proper maintenance include:

- * Difficult to Clean
- * Excessive Sedimentation
- * Erosion and Scour
- * Displaced Lining

1. The outflow conveyance system downstream of a retention facility should have adequate capacity to accommodate facility outflows. This will not only allow design outflows and water surfaces to be attained, but will also help achieve required drawdown times.

PLANNING AND DESIGN GUIDELINES
RETENTION FACILITIES

2. Outflow velocities should be high enough to prevent sedimentation and low enough to prevent erosion and scour.
3. Manholes, gates, and other suitable access points should be provided for cleaning and inspection. (See I. ACCESS for additional details.)

E. INLETS

Typical problems that impede or unnecessarily increase proper maintenance include:

- * Difficult to Clean
- * Excessive Sedimentation
- * Erosion and Scour
- * Displaced Lining

1. All inflow pipes and culverts should terminate at a head-wall or flared end section with adequate cutoff walls.
2. Linings placed downstream of facility inlets should accommodate design flows without erosion or scour. They should also facilitate removal of sediment and debris. Avoid loose stone, riprap, and other irregularly shaped linings which require hand removal of weeds, sediment, and debris. (See A. BOTTOMS AND PERMANENT POOLS for additional details.)
3. Provisions to minimize sediment from entering the facility should be considered. Street sweeping, upstream sedimentation basins and offsite soil stabilization measures can significantly reduce the frequency of required sediment removal operations.
4. To facilitate cleaning, inflow pipes should have a minimum diameter of 18 inches. The pipes should be constructed of durable materials, such as reinforced concrete.
5. Grading and landscaping around facility inlets should be designed to facilitate mowing, trimming, debris removal, and other general maintenance tasks. Grassed slopes which require mowing should not exceed 3 horizontal to 1 vertical. Vegetated cover which does not require mowing or non-vegetated linings should be used where steeper slopes are necessary.
6. Stable areas which provide maintenance personnel with firm footing should be provided at facility inlets. Linings such as reinforced concrete, gabions, and grouted riprap should be considered.

PLANNING AND DESIGN GUIDELINES
RETENTION FACILITIES

7. All nonvegetative linings which are bordered by grass should be designed to permit complete mowing along all edges.

8. Dry weather flow through a facility inlet should not interfere with routine maintenance tasks. Benching, low flow pipes and channels, drop structures, or similar measures should be utilized to convey low flow from the inlet into the permanent pool.

F. EMERGENCY OUTLETS

Typical problems that impede or unnecessarily increase proper maintenance include:

- * Difficult to Clean
- * Excessive Sedimentation
- * Erosion and Scour
- * Displaced Lining

1. Grass and other vegetative cover is encouraged whenever flow velocities and other design constraints permit. Surface and subsurface soil stabilization measures should be utilized to increase allowable flow velocities and to reduce erosion and scour. [Note: Safe passage of emergency overflows must receive first priority and must not be compromised by selection of emergency outlet lining.]

2. Where nonvegetative linings are required (see 1 above), loose stone, riprap, and other irregular linings which require hand removal of weeds and debris should be avoided.

3. All nonvegetative linings which are bordered by grass should be designed to permit complete mowing along all edges.

4. See B. DAMS, EMBANKMENTS, AND SIDE SLOPES for information regarding emergency outlet side slopes.

G. VEGETATIVE COVER

Typical problems that impede or unnecessarily increase proper maintenance include:

- * Erosion and Scour
- * Difficult to Mow
- * Poor Growth

1. To minimize maintenance efforts, the use of existing, undisturbed site vegetation is encouraged. To do so, the existing site topography must provide adequate storage volume.

**PLANNING AND DESIGN GUIDELINES
RETENTION FACILITIES**

2. Where disturbance of existing vegetation cannot be avoided, replacement with low maintenance vegetation with strong resistance to disease and allelopathic (self-weeding) characteristics is encouraged. In general, grass will be easier to establish and will provide better erosion protection than other types of ground cover vegetation. The use of grass varieties that are relatively slow growing and tolerant of poor soil conditions will minimize routine maintenance tasks such as mowing and fertilizing.

The need for supplemental fertilizing can be substantially reduced when the vegetative cover includes a percentage of nitrogen fixing species, such as white clover and other legumes. In addition to minimizing maintenance costs, a reduction in required fertilization will also minimize the potential pollution effects of nitrogen and nitrate runoff.

3. To promote lasting growth, grasses and other vegetative covers should be compatible with the prevailing weather and soil conditions and tolerant of periodic inundation and runoff pollutants.

4. To promote lasting growth, an adequate depth of suitable topsoil should be provided below all vegetative covers. A minimum thickness of 6 inches is recommended.

5. Construction plans and specifications should include requirements for establishing and maintaining all vegetative covers.

6. Additional information on vegetative covers is available from the USDA Soil Conservation Service, local Soil Conservation Districts, the South Jersey Resource Conservation and Development Council, the N.J. Cooperative Extension Service of Rutgers University, and County Cooperative Extension Service offices. Consultation with these agencies during facility planning, design, and review is encouraged.

H. TRASH RACKS

Typical problems that impede or unnecessarily increase proper maintenance include:

- | | |
|----------------------|-----------------------|
| * Difficult to Clean | * Difficult to Remove |
| * Structural Failure | * Excessive Debris |

1. Trash racks are intended to prevent trash and debris from blocking a retention facility's principal outlet and permanent pool drain by intercepting it at an upstream point. Therefore, the need for a trash rack should be based upon the relative sizes and shapes of the outlet and drain open-

PLANNING AND DESIGN GUIDELINES
RETENTION FACILITIES

ings and the anticipated debris as well as the consequences of outlet or drain clogging.

2. For durability, all trash rack components, including bars, hinges, fasteners, and clamps, should be constructed of lightweight, noncorrodible material such as aluminum. The components should have sufficient design strength to withstand anticipated loads caused by facility outflows, debris, and, where necessary, maintenance personnel.

3. To facilitate cleaning, trash racks should be comprised primarily of sloping bars aligned longitudinally (in the direction of flow). Perpendicular bars, aligned transverse to the direction of flow, should be added for strength and rigidity. These transverse bars should be located below the top face of the longitudinal bars and, if possible, should be round in section. (See PLATE 2-H for additional information.)

4. To minimize the frequency of cleaning, trash rack bars should be spaced close enough to collect debris which may block the outlet orifice or weir but allow passage of smaller debris which will not. In general, longitudinal bars should be spaced a distance equal to $1/3$ the diameter of the outlet orifice or $1/3$ the width of the outlet weir. Minimum and maximum spacings of 1 inch and 6 inches on center, respectively, are recommended. Transverse bars should be spaced as necessary for strength and rigidity. (See PLATE 2-H for additional information.)

5. Trash racks should be hinged or attached with non-corrodible, removable fasteners to allow access to the outlet orifice or weir by maintenance personnel. Lightweight trash racks are easier to lift, repair, and clean behind. (See PLATE 2-H for additional information.)

6. Trash racks at principal outlets should be accessible for cleaning with the water level at the normal pool elevation and, if necessary, at the facility's maximum design water surface elevation. Gratings, walkways, or other stable areas of adequate size should be provided at all principal outlet trash racks to provide firm footing for maintenance personnel and equipment.

7. Stable areas of adequate size should be provided at all trash racks which protect permanent pool drains. Concrete pads or other firm surface is recommended.

UNHINGED RACKS SHOULD BE MOUNTED ON SUITABLE SEATS EMBEDDED IN WINGWALLS, SEE TOP RACK DETAIL.

HINGES FACILITATE LIFTING AND ACCESS.

ROUND BAR ENDS TO PERMIT RACK TO SWING UP

LONGITUDINAL RACK BARS SHOULD BE RECTANGULAR IN SECTION. RECOMMENDED SPACING = $1/3$ ORIFICE DIAMETER. (MINIMUM 1 INCH).

LIGHTWEIGHT NONCORRODIBLE TRASH RACK

SECURE RACK TO WALL OR BOTTOM W/ REMOVABLE, NONCORRODIBLE FASTENERS TO PREVENT UN-AUTHORIZED OPENING

BEVEL BAR ENDS TO MEET BOTTOM SLAB

TRANSVERSE BARS SHOULD BE RECESSED BELOW THE TOP FACE OF TRASH RACK. SPACE BARS AS REQUIRED FOR RACK RIGIDITY AND STRENGTH. CIRCULAR SECTION PREFERRED.

WINGWALL SLOPE GREATER THAN OR EQUAL TO SLOPE OF DAM/EMBANKMENT
MAXIMUM SLOPE = 2 HORIZ. : 1 VERT.

TRASH RACK PROTECTS OUTLET ORIFICES. RACK SHOULD BE ACCESSIBLE FROM STRUCTURE TOP

PERMANENT POOL

TOP OF SLOPE

LIGHTWEIGHT, NONCORRODIBLE RACK

METAL ANGLE FORMS RACK SEAT

PROVIDE ANCHORED SEAT FOR RACK. SECURE RACK WITH REMOVABLE, NON-CORRODIBLE FASTENERS. HINGES AND LATCH FACILITATE ACCESS TO STRUCTURE INTERIOR

NONCORRODIBLE REMOVABLE EXPANSION ANCHOR BOLT

ANCHOR IN CONCRETE

DAM TOP WIDTH

TOP RACK ENCLOSES OUTLET STRUCTURE AND PROVIDES OVERFLOW CAPACITY AND INTERIOR ACCESS. BAR SPACING AND STRENGTH SHOULD PROVIDE SAFE FOOTING FOR MAINTENANCE PERSONNEL.

REINFORCED CONCRETE OUTLET STRUCTURE, SEE PLATE 2-B.

UPSTREAM SLOPE OF DAM OR EMBANKMENT

EDGE OF PERMANENT POOL

**NJDEP
SWMF MAINTENANCE MANUAL**

**RETENTION BASIN
TRASH RACKS
TYPICAL DETAILS**

PLATE 2-H

SEE PARAGRAPHS 3, 4, AND 5 ON PAGE PLAN-51 FOR ADDITIONAL INFORMATION

PLANNING AND DESIGN GUIDELINES
RETENTION FACILITIES

I. ACCESS

Typical problems that impede or unnecessarily increase proper maintenance include:

- * Inadequate or Unsafe Access to Facility Components
- * Heavy Gratings and Hatches
- * Corroded Locks
- * Lack of Fence Gates

1. The facility must be readily accessible from a street or other public right-of-way. Inspection and maintenance easements, connected to the street or right-of-way, should be provided around the entire facility. The exact limits of the easements and rights-of-way should be specified on the project plans and other appropriate documents.

2. Field evaluations conducted during the development of this Manual indicate that readily visible retention facilities receive more and better maintenance than those in less visible, more remote locations. This finding should be kept in mind during overall site layout. Readily visible facilities can also be inspected faster and more easily by maintenance and mosquito control personnel.

3. Access roads and gates should be wide enough to allow passage of necessary maintenance vehicles and equipment, including trucks, backhoes, grass mowers, and mosquito control equipment. In general, a minimum right-of-way width of 15 feet and a minimum roadway width of 12 feet is recommended.

4. To facilitate entry, a curb cut should be provided where an access road meets a curbed roadway.

5. To allow safe movement of maintenance vehicles, access ramps should be provided to the shoreline of all retention facilities with side slopes greater than 5 feet in height. All access ramps should not exceed 10 per cent in grade.

6. Access roads and ramps should be stable and suitably lined to prevent rutting and other damage by maintenance vehicles and equipment.

7. When backing-up is difficult or dangerous, turnaround areas should be provided at the end of all access roads.

8. To expedite overall maintenance efforts, vehicle and equipment staging areas should be provided at or near each facility site.

PLANNING AND DESIGN GUIDELINES
RETENTION FACILITIES

9. A suitable number of gates should be provided in all fences. The gates should be wide enough to allow passage of necessary equipment and personnel. They should be appropriately located so that they can be fully opened without interference by trees, parked cars, existing or proposed grades, or other obstructions. If it is necessary to lock a gate, it should be done with a noncorrodible chain and padlock. This will permit the installation of additional padlocks on the chain (each padlock becomes a link in the chain), thereby allowing authorized access through the gate by more than one person without the need for multiple keys.

10. Safe, suitable access for maintenance personnel and equipment should be provided to the exterior of each facility component. In doing so, avoid remote component locations, steep slopes, unstable surfaces and linings, and narrow walkways.

11. Suitable access should be provided along both sides of a fence for mowing, trimming, and fence repair.

12. Safe, suitable access for maintenance personnel and equipment should be provided to the interior of each appropriate facility component. In doing so, avoid heavy hatches, gratings, and other covers. Railings, grab rails, slip-resistant steps, low flow channels, benchings, and hinged, lightweight access covers greatly facilitate interior maintenance. Sufficient interior space should also be provided. A minimum horizontal dimension of 4 feet is recommended.

J. PERIMETERS

Typical problems that impede or unnecessarily increase proper maintenance include:

- * Difficult to Mow or Clean
- * Inadequate Size
- * Too Close to Adjacent Structures

1. Field evaluations conducted during the development of this Manual indicate that readily visible facilities receive more and better maintenance than those in less visible, more remote locations. This finding should be kept in mind during overall site layout. Readily visible facilities can also be inspected faster and more easily by maintenance and mosquito control personnel.

2. Fences, when required for safety or other purposes, should be located to minimize interference with grass mowing and trimming. Suitable access should be provided along both sides.

PLANNING AND DESIGN GUIDELINES
RETENTION FACILITIES

3. To allow safe movement of maintenance personnel and equipment, fences should be located at least 3 feet beyond the top or toe of any slope steeper than 5 horizontal to 1 vertical.

4. Fences should be constructed of durable, vandal-resistant materials. Fences must meet all local code requirements.

5. To minimize the amount of required trimming, fences in grassed areas should be installed, whenever practical, with a bottom rail set high enough above finished grade to allow mowing beneath it.

6. Grassed areas beyond the tops of retention facilities should have a minimum slope of 2 per cent to promote effective surface drainage and thorough drying.

7. Perimeters should be planned and designed to discourage vandalism and dumping of trash and debris.

8. Facility perimeters should be large enough to allow movement and operation of maintenance and mosquito control equipment. A minimum perimeter width of 25 feet between the facility and adjacent structures is recommended along at least one side of the facility. This portion of the perimeter should be readily accessible from a street or other public right-of-way.

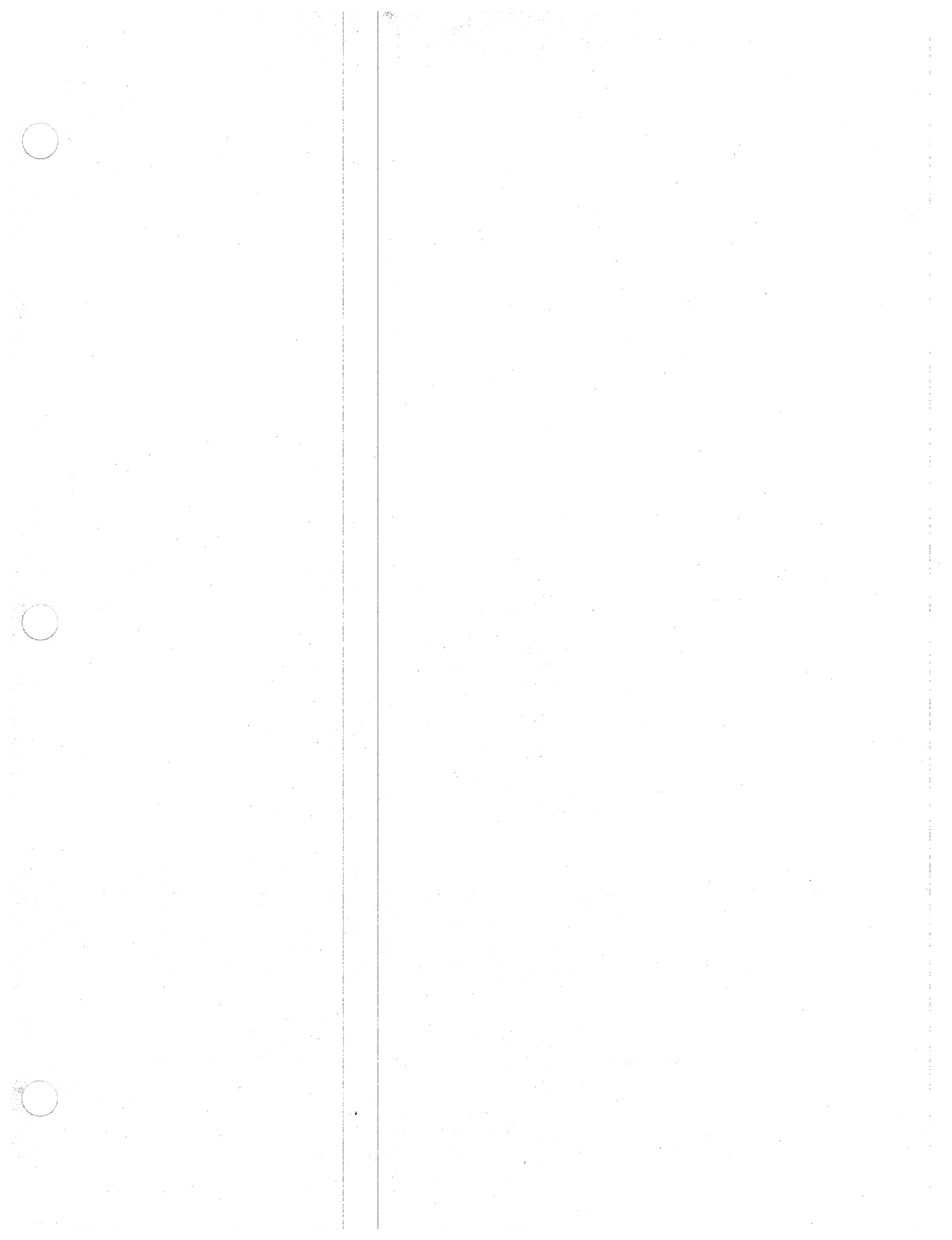

**NEW JERSEY
DEPARTMENT OF ENVIRONMENTAL PROTECTION
STORMWATER MANAGEMENT FACILITIES
MAINTENANCE MANUAL**

**CHAPTER THREE
CONSTRUCTION INSPECTION**

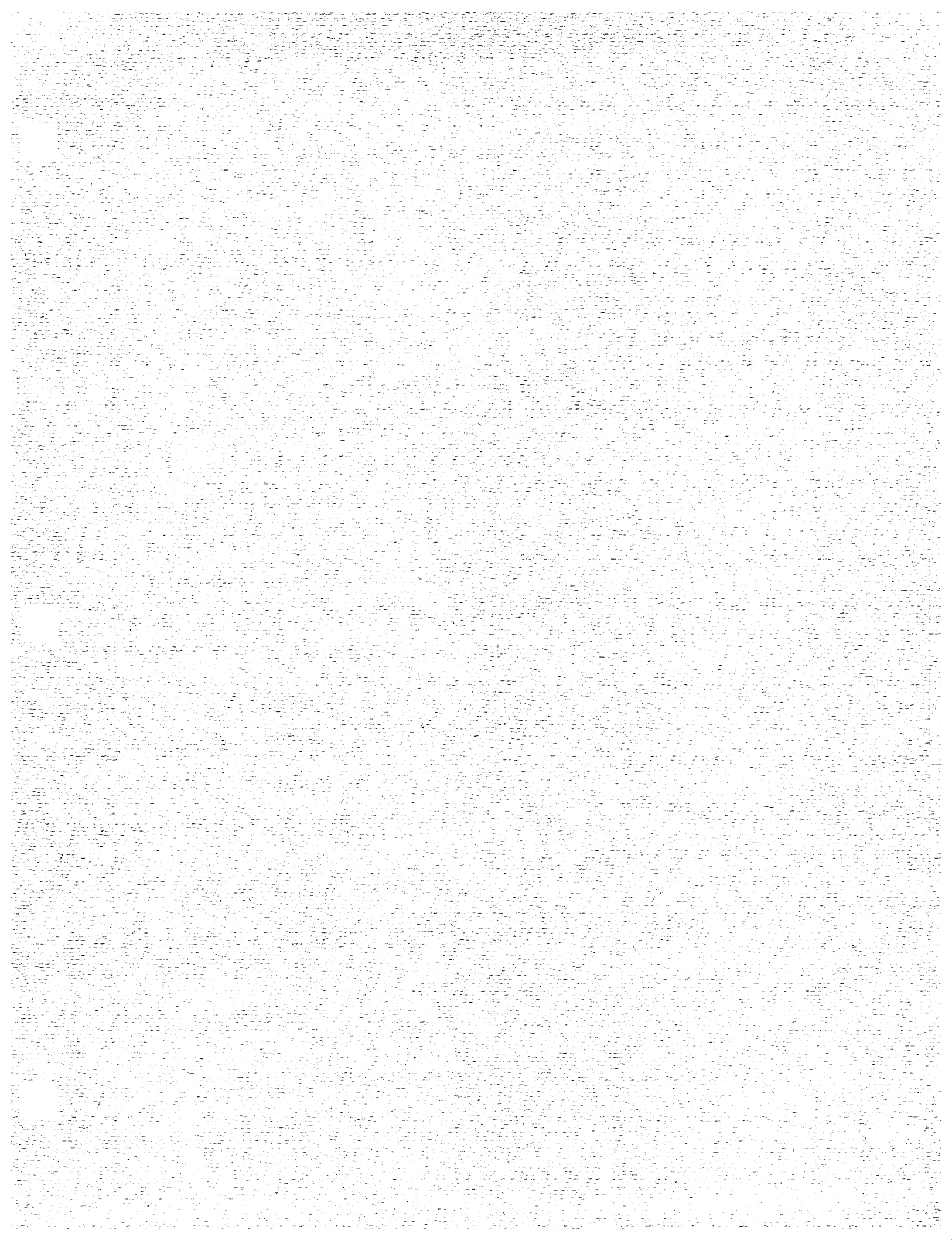

N.J. DEPARTMENT OF ENVIRONMENTAL PROTECTION
STORMWATER MANAGEMENT FACILITIES MAINTENANCE MANUAL

CHAPTER THREE - CONSTRUCTION INSPECTION

TABLE OF CONTENTS

A. OBJECTIVES	INSPECT-1
B. OVERVIEW	INSPECT-2
C. INTENDED READERS	INSPECT-3
D. TYPICAL SWMF MAINTENANCE PROBLEMS THAT POOR CONSTRUCTION CAN CREATE	INSPECT-4
E. RECOMMENDED CONSTRUCTION INSPECTION PRACTICES	INSPECT-6
* PRECONSTRUCTION PHASE	INSPECT-6
* CONSTRUCTION PHASE	INSPECT-7
* POST CONSTRUCTION PHASE	INSPECT-9

TABLE 3-1	SUMMARY OF CONSTRUCTION INSPECTION PRACTICES	INSPECT-11
TABLE 3-2	TYPICAL PRECONSTRUCTION MEETING TOPICS	INSPECT-13

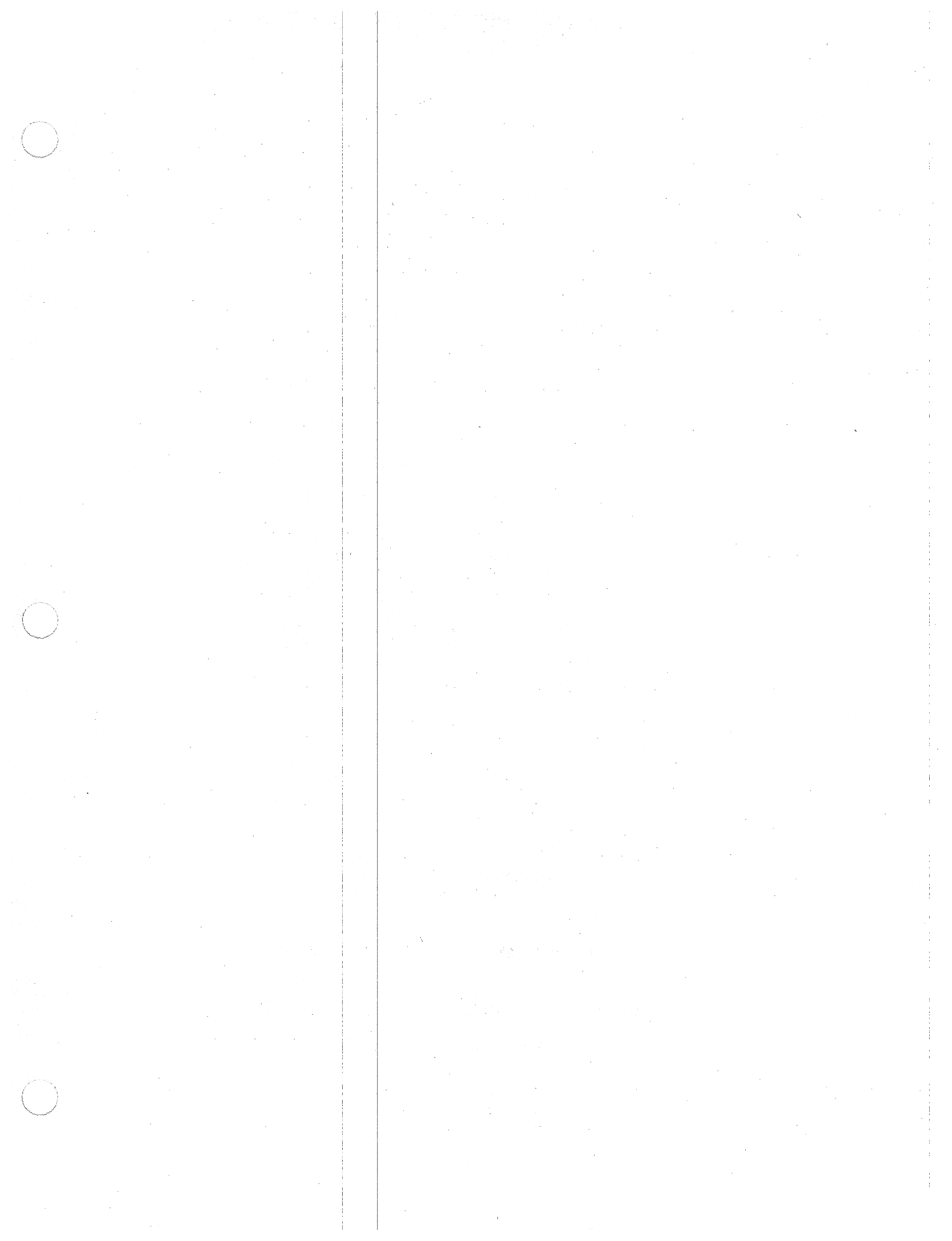

CONSTRUCTION INSPECTION

A. OBJECTIVES

This Chapter of the **STORMWATER MANAGEMENT FACILITIES MAINTENANCE MANUAL** discusses the importance of proper construction inspection practices in helping to achieve Stormwater Management Facilities (or SWMFs) that require a minimum amount of maintenance effort and expense. The degree and frequency of required maintenance at a SWMF depends not only on the thoroughness of its planning and design, but also on the quality and accuracy of its construction. An ideal facility design, including clear and concise plans and specifications, does not in itself guarantee that the completed facility will require the low level of maintenance envisioned by its designer. Poor quality materials and faulty or inattentive construction can negate all the hard work that was spent during the planning and design phase to create a facility that would minimize required maintenance.

The importance of taking the proper steps during the SWMF's construction phase to assure that the constructed facility meets the intent of the design can not be overemphasized. Thorough construction inspection provides the necessary link between the owner, the contractor, and the designer that can avert situations which can otherwise result in avoidable maintenance problems. With that in mind, this Chapter of the **STORMWATER MANAGEMENT FACILITIES MAINTENANCE MANUAL** will:

- * Describe the important role that construction inspection plays in assuring quality SWMF construction which meets the low maintenance intent of the design.
- * Recommend procedures and practices which will help achieve completed SWMFs that are free from construction related defects.
- * Recommend specific tasks and procedures for the construction inspector.
- * Present typical maintenance problems which can result from faulty construction and which can be prevented or minimized through thorough construction inspection practices.

It should be noted that proper construction inspection is based upon several factors, including relevant codes and regulations, legal responsibilities, insurance, liability, and specific construction and inspection contract language. This Chapter of the SWMF Maintenance Manual addresses only those aspects of construction inspection that are conducive to achieving high quality SWMFs that require minimum levels of maintenance. Consideration for all relevant factors must be included in any construction inspection activities, including those discussed herein.

CONSTRUCTION INSPECTION

B. OVERVIEW

Relatively speaking, SWMFs are not exceptionally complex construction projects. Typically, construction of a SWMF includes such items as excavation, grading, placement and compaction of fill material, pipe laying, construction of reinforced concrete structures, and installation of appurtenant components. Under normal conditions, SWMFs are certainly not the most complex structures imaginable.

This does not imply in any way that the quality of construction or materials can in any way be compromised. To be sure, all construction must be performed with superior skill and close attention to detail. Only through the use of sound construction techniques and quality materials can the expected durability and maintainability of the SWMF be assured. Construction related maintenance problems, however, cannot simply be avoided by entrusting a qualified contractor to build the facility from a set of plans and specifications. As a rule, unforeseen situations inevitably arise during the construction phase which require either deviation from the original plans or modified construction techniques.

Under normal circumstances, the actual construction of a SWMF is performed by an independent contractor; that is, a person or company which has had no direct input to the project during its design phase. Left to himself, the contractor must rely solely on the available plans and specifications to create the intended facility. Although his experience and expertise can go a long way towards resolving the inevitable construction questions, a direct link between the contractor and facility designer is required to insure that the best possible facility is constructed. This link is provided by the construction inspector or inspection team.

The value of thorough construction inspection procedures cannot be overemphasized. Poor SWMF construction can lead to many serious maintenance and safety problems, including standing water, wet bottoms, slope erosion, channel scour, mosquito breeding, and even structural failure of dams, embankments, slopes, and outlet structures. It is certainly easier and less expensive to construct a SWMF correctly the first time than it is to repair, reconstruct, or live with (and continually pay for) construction defects and the facility maintenance problems they create. The cost to repair or reconstruct all or portions of a SWMF can be substantial and may include legal fees and other expenses that were not anticipated during the original construction effort. Additionally, the quality of repaired or reconstructed work, by its very nature, can fall below the level normally provided by the original work.

CONSTRUCTION INSPECTION

Construction inspection does, of course, cost money. The wages for inspectors and office support personnel and the cost of equipment may add up to what appears to be a considerable sum. However, over the life of the facility, this expense can be recovered many times over through reduced maintenance and repair efforts. It is difficult to put exact dollar values on the benefit/cost ratio of construction inspection, for each project must be considered individually with cost savings established on a case by case basis. Research has shown, however, that the lack of adequate construction inspection can be a primary cause of otherwise avoidable SWMF maintenance problems.

C. INTENDED READERS

In attempting to achieve a "minimum maintenance" SWMF, construction inspection is often one aspect of a SWMF project that does not receive the attention it deserves from owners, project managers, and government officials. With that thought and the objectives listed above in mind, those who will benefit most from this Chapter of the SWMF Maintenance Manual include:

- * **Project and Construction Managers**, who should view construction inspection as a vital quality control measure that is in the best interests of all those concerned with the creation of a SWMF.
- * **Construction Inspectors**, who should clearly understand their project responsibilities and the specific tasks that are critical to achieving the intended design.
- * **Contractors**, who should realize that proper construction inspection will help avoid construction problems and delays and assure both quality workmanship and rapid completion.
- * **Code Officials**, who should fully understand the important role they must play in achieving a high quality, minimum maintenance SWMF.

Additionally, several other readers can benefit from this Chapter of the Manual. They include:

- * **Planners, Designers and Project Reviewers**, who should be aware of the value of proper construction inspection while preparing or reviewing construction plans, specifications, and other contract documents.
- * **Project Managers**, whose responsibilities include providing assurance that the project will be constructed to the best possible standards.

CONSTRUCTION INSPECTION

* **SWMF Owners**, who should realize that is in their long term interest to create the highest quality SWMF and thereby avoid unnecessarily high maintenance costs in the future.

D. TYPICAL SWMF MAINTENANCE PROBLEMS THAT POOR CONSTRUCTION CAN CREATE

There are numerous and otherwise avoidable SWMF maintenance problems and expenses that can result from poor quality construction procedures and materials. Presented below are some typical examples of construction related defects or flaws which can cause additional SWMF maintenance and/or premature facility deterioration. Awareness of these maintenance problems and their construction-related causes can help everyone avoid them.

1. Ground Settlement

Ground settlement following construction can be the result of many factors, including but not limited to; incomplete compaction, unsuitable backfill materials, poor subsurface conditions unknown at the time of design, and unnecessary disturbance during construction of subsurface soils which must act as foundations for SWMF structures. Settlement of the facility bottom can create localized ponding areas which cannot drain to the facility's outlet structure or low flow channel. This can unnecessarily complicate, delay, or even prevent required grass mowing. It can also create mosquito breeding habitats which will require expensive treatment by trained specialists. Settlement of side slopes can create localized erosion problems. Settlement of dams, embankments, and outlet structure foundation soils can result in serious structural damage and total facility failure. In any case, ground settlement can require additional expense in the form of extra maintenance and/or repair efforts.

2. Cracked, Spalled, or Deteriorated Concrete

Concrete is a versatile and durable building material. However, proper handling, placing, and curing are vital to achieving that durability and longevity. Premature failure of a concrete structure can result in the need for expensive repairs. Many defects in a concrete structure are not readily discernible immediately after the structure is completed, and it may take several years for the defect to become apparent. Close inspection of each step of the actual construction, therefore, is vital to assure the longevity and reliability of the concrete structure.

CONSTRUCTION INSPECTION

3. Incorrect Elevations, Grades and Dimensions

The accuracy with which pipe, orifice, and low flow channel inverts, weir crests, bottom slopes, outlet structure dimensions, and other SWMF components can be constructed may not match that specified on the plans. While some of the specified values are not critical to the performance of the SWMF and, therefore, some variation is acceptable, the tolerance on critical components such as orifice inverts, low flow channel grades, and bottom slopes can have serious adverse impacts on the performance of the SWMF and its required maintenance.

4. Poor Grass Growth

Normally, the SWMF contractor is responsible for establishing and maintaining suitable grass and other vegetative covers for a specified period of time after construction has been completed. However, inadequate or unsuitable topsoil, lack of fertilizer, and insufficient watering may result in weak grass covers that are unable to withstand more than one seasonal cycle. Once the contractor's responsibility for the grass cover has ended, the cost of any required repair or replacement must come from the facility's maintenance budget.

5. Incorrectly Installed Fittings and Appurtenances

Although relatively small in size, such components as orifice plates, hinges, anchor bolts, and hasps are vital to the correct functioning and low maintenance of a SWMF. Careless installation of these components can complicate maintenance efforts and require otherwise avoidable repairs.

6. Missing or Hidden Components

Not all SWMF components are visible once the facility has been completed. The omission or incorrect installation of items such as compacted fill, geotextile fabrics, reinforcing steel, pipe jointing, gabion lacing and diaphragms, and stone bedding can only be detected through close inspection of each construction step. The effects of these omissions or errors may not show up for several years. The maintenance problems and expenses they cause may continue for many more.

CONSTRUCTION INSPECTION

E. RECOMMENDED CONSTRUCTION INSPECTION PRACTICES

Effective SWMF construction inspection begins well before the actual start of construction and does not end until the entire construction contract period has expired. Following this sequence, effective construction inspection can be divided into Preconstruction, Construction, and Post Construction phases. A description of each project phase and the recommended construction inspection practices that should be followed during each are described below. For easy reference, a summary of the recommended inspection practices is presented in Table 3-1.

PRECONSTRUCTION PHASE

Between the time the construction contract is awarded and the moment that actual SWMF construction begins, the construction inspection team must do a great deal of preliminary work. The inspector(s) should become familiar with the facility plans and specifications and note especially complex components, difficult site conditions, and other potential problem areas that may require special attention. A check should be made that all necessary permits and easements have been obtained and that all required documentation is readily available. Start-of-work notifications should also be sent to all appropriate agencies, which may include the NJDEP, local Soil Conservation District, county engineering department, and municipal building code official.

Soon after the award of the construction contract, a preconstruction meeting should be held between the SWMF's owner, contractor, project engineer, and inspector(s). While it may not always be possible to have these exact individuals attend, every effort should be made to do so. These people either have or will play key roles in the construction of the SWMF and should be present. Attendance at the preconstruction meeting should also include representatives of any subcontractors, utility companies, funding agencies, and regulatory agencies. In so far as possible, those attending the meeting should also be the same people who will be available for consultation during facility construction. Many problems and misunderstandings can be avoided by dealing with the same group of people throughout the entire construction period.

A preconstruction meeting serves several valuable purposes, not the least of which is simply to allow these key people to meet face to face. Since much of the communication during the actual construction phase is by letter or telephone, the preconstruction meeting is often the only time that some of these people will meet. It is important that they know each other as individuals, not just as a voice or a signa-

CONSTRUCTION INSPECTION

ture. Knowing one another personally can be a great advantage in solving subsequent problems encountered during the construction.

At the preconstruction meeting, a list of telephone numbers where all key project personnel can be reached at any time should be prepared and copies provided to the inspector, contractor, owner, project engineer, and local police and fire departments. Hopefully the list will not be needed, but if it is, it can be instrumental in preventing serious injury or damage. The inspector should update the telephone list as necessary.

Items on the agenda of the preconstruction meeting should include:

- 1) The project's overall purpose and objective.
- 2) Specific areas or details of the project that are particularly complex or otherwise require special attention.
- 3) Construction schedules and deadlines.
- 4) The establishment of a chain of command for problem solving.

A detailed list of recommended preconstruction meeting topics is summarized in Table 3-2.

CONSTRUCTION PHASE

During the actual construction phase, a great deal of activity is usually taking place simultaneously. If the construction inspection process is to be truly effective, it is imperative for the inspector to not only understand and inspect the current construction activity but to think beyond that activity and to anticipate problems that may be encountered during the next construction step. As described above, it is far better to perform the SWMF construction correctly the first time than it is to correct or repair already completed work. The inspector has the ability to alert the contractor to potential problems that lay ahead and to work with him to develop alternate methods or techniques that can avoid the problems without affecting the progress of the work. Frequent communication between the inspector and contractor throughout each day can greatly assist this process.

The responsibilities of the construction inspector are many and varied. Recommended inspection practices intended to improve the performance of SWMF construction inspection are described below. It should be noted that, while these

CONSTRUCTION INSPECTION

recommendations are intended particularly for the inspection of SWMFs, they are also descriptive of helpful construction inspection procedures in general. However, as stated above, the inspector's exact responsibilities will depend upon many factors, including specific inspection contract language, insurance coverage, and pertinent codes and regulations. Consideration must be given to all relevant factors before proceeding with any construction inspection activity.

1. Daily Reports

The inspector should keep a log of all pertinent activity occurring at the construction site relative to the project. Items to note include all construction activity, weather and working conditions, arrival and departure times of vehicles, equipment, materials, and key project personnel. This log becomes especially important when disputes arise, and can often be the deciding factor in settling them. Additionally, the log should be summarized daily in the form of a brief report which should be made available to both the project engineer and owner.

2. Shop Drawings

Shop drawings should be required from the SWMF contractor for all facility components. Regardless of its complexity or relative importance, each SWMF component will benefit from having shop drawings submitted and approved prior to its construction. Shop drawings should include methods of construction, as well as detailed specifications of the materials. Although the shop drawing review and approval process may seem tedious at times, particularly for simple facility components, experience has shown that the problems solved on paper prior to construction can prevent major problems later in the field.

3. Progress Meetings

The inspector should schedule regular meetings with the contractor to discuss the progress of the construction. These meetings should be in addition to their daily discussions of the work. The progress meetings will help assure coordination between the various aspects of the work and will afford both parties the opportunity to discuss current or anticipated problems. In addition, the inspector should encourage the project engineer to make periodic visits to the site in order to gain his insight into the intended appearance, configuration, or other aspect of the facility.

CONSTRUCTION INSPECTION

4. Extra Work and Change Orders

Speaking practically, extra work and/or change orders will almost inevitably be required during construction. The design phase of any project cannot anticipate all the conditions that may be encountered in the field. Often the contractor, based upon his experience or available equipment, can recommend changes that will aid the progress of the work or enhance the quality of the design. Regardless of its cause or basis, the inspector and project engineer should evaluate each extra work charge and change order expeditiously, determine if it is in fact legitimate, and make recommendations to accept, reject, or negotiate the charge or change on a timely basis. Unnecessary delays in resolving change orders and extra charges can result in animosity, reduced communication, poor workmanship during the remainder of the work, and, ultimately, extra costs at the end.

The extra charge or change order review process is often difficult, particularly in determining the legitimacy of an extra work claim. The inspector must have sufficient experience and a thorough knowledge of the facility construction to objectively evaluate claims. Accurate inspection records, including comprehensive daily construction reports as described above, will be invaluable to the review. It should also be noted that, if the construction plans and specifications are complete and the inspector is doing his job thoroughly, the number of extra work claims and/or change orders during the construction of a SWMF should be minimal.

5. Final Inspection and Punch List

When the construction at a SWMF site is substantially complete, but before final cleanup has begun, a complete and thorough inspection of the site should be undertaken by the inspector, who should then prepare a list (commonly called a Punch List) of items that require additional work or attention. Final payment to the contractor is usually contingent upon completion of the Punch List items. As such, the Punch List is an effective tool that the inspector can use to help insure that all facility construction is complete and correct even before the contractor demobilizes and leaves the project site.

POST CONSTRUCTION PHASE

After the Punch List items have been completed and final payment made to the contractor (except for any retained percentage), the contractor should be contractually obligated to correct or repair the new SWMF as warranted for a period of at least one year. During this time, the inspector

CONSTRUCTION INSPECTION

should perform periodic inspections of the facility and immediately bring any problems to the contractor's attention. Having done so, the inspector should then regularly encourage the contractor to perform the warranted repairs in a timely manner.

Record Plans should be completed promptly following construction of a facility. These plans should show all actual as-built dimensions, elevations, and locations of all facility components. Generally, the Record Plans are produced by making appropriate revisions to the construction plans. The Record Plans should be made available to the owner, municipality, maintenance staff, and all agencies which have any jurisdiction over the facility. Aside from providing a permanent record of the actual facility constructed, these plans are important for establishing maintenance procedures, and will also facilitate any future rehabilitation or modifications of the facility.

Finally, the orderly filing and safe storage of all records pertaining to the construction inspection should be systematically performed throughout all three phases of the SWMF construction. All unfiled records or reports remaining at the end of the project should also be promptly filed. Inspection records are virtually useless if they cannot be readily located or are poorly organized.

CONSTRUCTION INSPECTION

TABLE 3-1

N.J. DEPARTMENT OF ENVIRONMENTAL PROTECTION
STORMWATER MANAGEMENT FACILITY MAINTENANCE MANUAL

SUMMARY OF CONSTRUCTION INSPECTION PRACTICES

A. PRECONSTRUCTION

1. Review Purpose of the Project
2. Review Plans and Specifications
3. Obtain Pertinent Permit Documents
4. Review Permit Conditions
5. Obtain Pertinent Easement Documents
6. Review Easement Conditions and Restrictions
7. Schedule and Conduct Preconstruction Meeting
8. Obtain List of Emergency Phone Numbers
9. Obtain List of Key Personnel

B. CONSTRUCTION

1. Observe All Pertinent Construction Activity
2. Be Familiar with Construction Procedures
3. Anticipate Problems
4. Keep a Diary of all Pertinent Activities
5. Write Daily Construction Reports
6. Review Shop Drawings
7. Consult with the Contractor Frequently
8. Conduct Progress Meetings
9. Review Change Orders and Extra Claims

CONSTRUCTION INSPECTION

TABLE 3-1 (CONTINUED)

10. Prepare Punch List
11. Conduct Final Inspection

C. POST CONSTRUCTION

1. Perform Periodic Inspections
2. Notify Contractor of Necessary Work
3. Inspect Corrected Work
4. Prepare Record Plans
5. File all Pertinent Contract and Inspection Records

CONSTRUCTION INSPECTION

TABLE 3-2

N.J. DEPARTMENT OF ENVIRONMENTAL PROTECTION
STORMWATER MANAGEMENT FACILITY MAINTENANCE MANUAL

TYPICAL PRECONSTRUCTION MEETING TOPICS

A. GENERAL INFORMATION

1. Attendance
2. Purpose of Project and Background Information
3. Emergency Phone Numbers
4. Construction Photograph Requirements
5. Project Sign Requirements
6. Starting Date
7. Review of Contract Documents, including Insurance Certificates, Bonds and Subcontractors Documents
8. Field Office Requirements
9. Responsibility for Notifications of Affected Property Owners and Residents
10. Chain of Command for Communications and Correspondence
11. Construction Schedules
12. Key Personnel and their degree of involvement in the Project (Inspector, Owner, Engineer, Agencies, etc.)

B. POLICE AND FIRE DEPARTMENT CONCERNS

1. Traffic Control
2. Barricades and Signs Conforming to the Uniform Manual
3. Noise Ordinance Considerations
4. Working Hours, including Weekend and Holidays
5. Vandalism and Preventative Measures

CONSTRUCTION INSPECTION

TABLE 3-2 (CONTINUED)

6. Flagmen and Traffic Control Officers
7. Equipment Storage and Vehicle Parking
8. Emergency Vehicle Access
9. Underground Tank Locations and Precautionary Construction Procedures
10. Storage and Use of Hazardous Materials

C. UTILITIES

1. Utility Locations and Mark-Outs
2. Coordination of Utility Relocations
3. Emergency Phone Numbers of Utility Companies

D. FUNDING AND PAYMENTS

1. Funding Sources and Availability
2. Procedures and Dates for Payment Estimates
3. Dates for Payments to Contractor
4. Breakdown of Lump Sum Items for Partial Payment
5. Policy for Payment for Materials on Site at the Close of a Payment Period
6. Retained Monies during and after Construction
7. Requirements of Funding Agencies

E. CHANGE ORDERS AND EXTRA CLAIMS

1. Requirements for Additional Work and Submittal of Change Orders
2. Procedures and Schedule for Review and Recommendations of Change Orders
3. Procedures for Negotiating Extra Claims and Change Orders

CONSTRUCTION INSPECTION

TABLE 3-2 (CONTINUED)

F. CONSTRUCTION ACCESS AND EASEMENTS

1. Easement Locations and Maps
2. Responsibility for Locating and Staking Easements
3. Available Survey Data for the Site
4. Access Requirements and Staging Areas
5. Easement Restrictions and Restoration Requirements

G. CONSTRUCTION DETAILS

1. Unique or Complex Aspects of the Project
2. Testing Laboratories and Sampling Procedures
3. Cold and Hot Weather Protection Measures
4. Blasting Requirements
5. Dump Site Location for Construction Related Materials
6. Shop Drawing Requirements and Review Procedures
7. Specific Construction Techniques and Procedures
8. Review of Technical Section of the Specifications

H. PERMITS

1. Status of all Required Federal, State and Local Permits
2. Permit Restrictions and Conditions
3. Start-of-Work Notifications

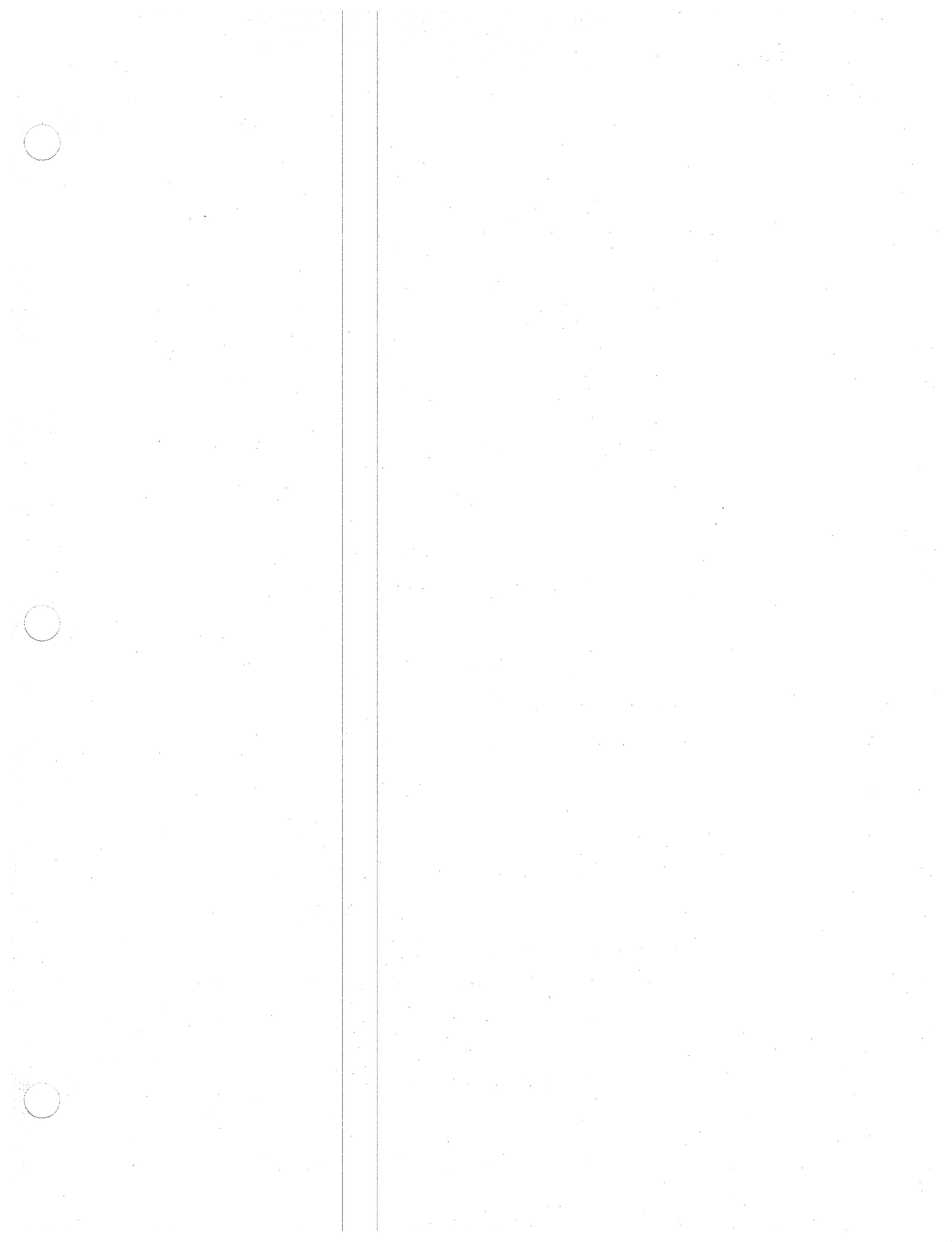

**NEW JERSEY
DEPARTMENT OF ENVIRONMENTAL PROTECTION
STORMWATER MANAGEMENT FACILITIES
MAINTENANCE MANUAL**

**CHAPTER FOUR
MAINTENANCE EQUIPMENT AND PROCEDURES**

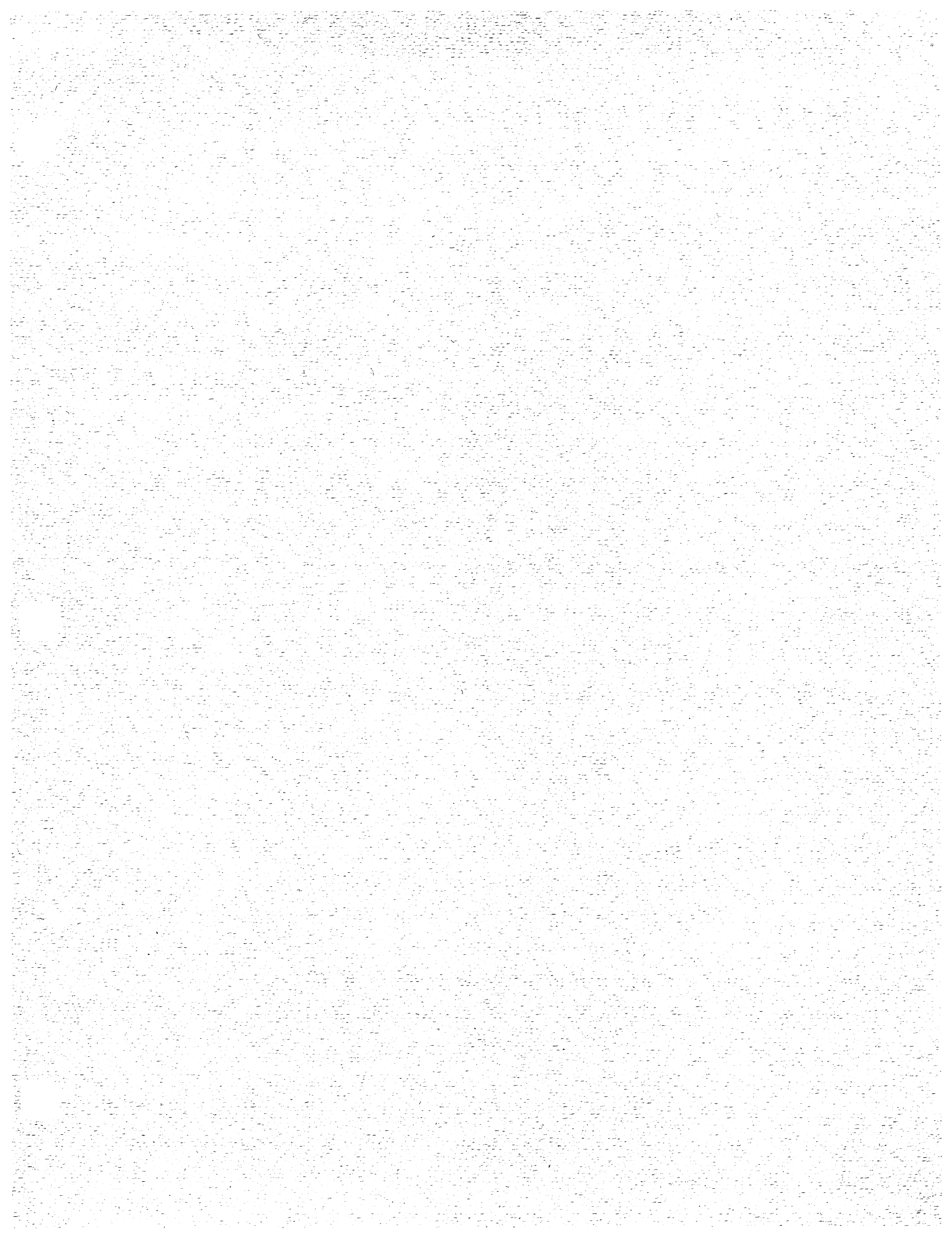

N.J. DEPARTMENT OF ENVIRONMENTAL PROTECTION
STORMWATER MANAGEMENT FACILITIES MAINTENANCE MANUAL

CHAPTER FOUR - MAINTENANCE EQUIPMENT AND PROCEDURES

TABLE OF CONTENTS

A. OBJECTIVES	MAINT-1
B. INTENDED READERS	MAINT-1
C. DEFINITIONS	MAINT-2
D. THE IMPORTANCE OF SWMF MAINTENANCE	MAINT-2
E. COMPREHENSIVE SWMF MAINTENANCE - AN OVERVIEW	MAINT-5
F. SWMF MAINTENANCE PROCEDURES	MAINT-8
* PREVENTATIVE MAINTENANCE PROCEDURES	MAINT-9
* CORRECTIVE MAINTENANCE PROCEDURES	MAINT-12
* AESTHETIC MAINTENANCE PROCEDURES	MAINT-15
G. TABLES, CHECKLISTS, AND LOGS	MAINT-16

TABLE 4-1 SUMMARY OF MAINTENANCE PROCEDURES	MAINT-17
TABLE 4-2 MAINTENANCE EQUIPMENT AND MATERIALS	MAINT-18
TABLE 4-3 MAINTENANCE WORK ORDER AND CHECKLIST ...	MAINT-20
TABLE 4-4 MAINTENANCE LOG	MAINT-23
TABLE 4-5 INSPECTION CHECKLIST	MAINT-26
TABLE 4-6 INSPECTION LOG	MAINT-29

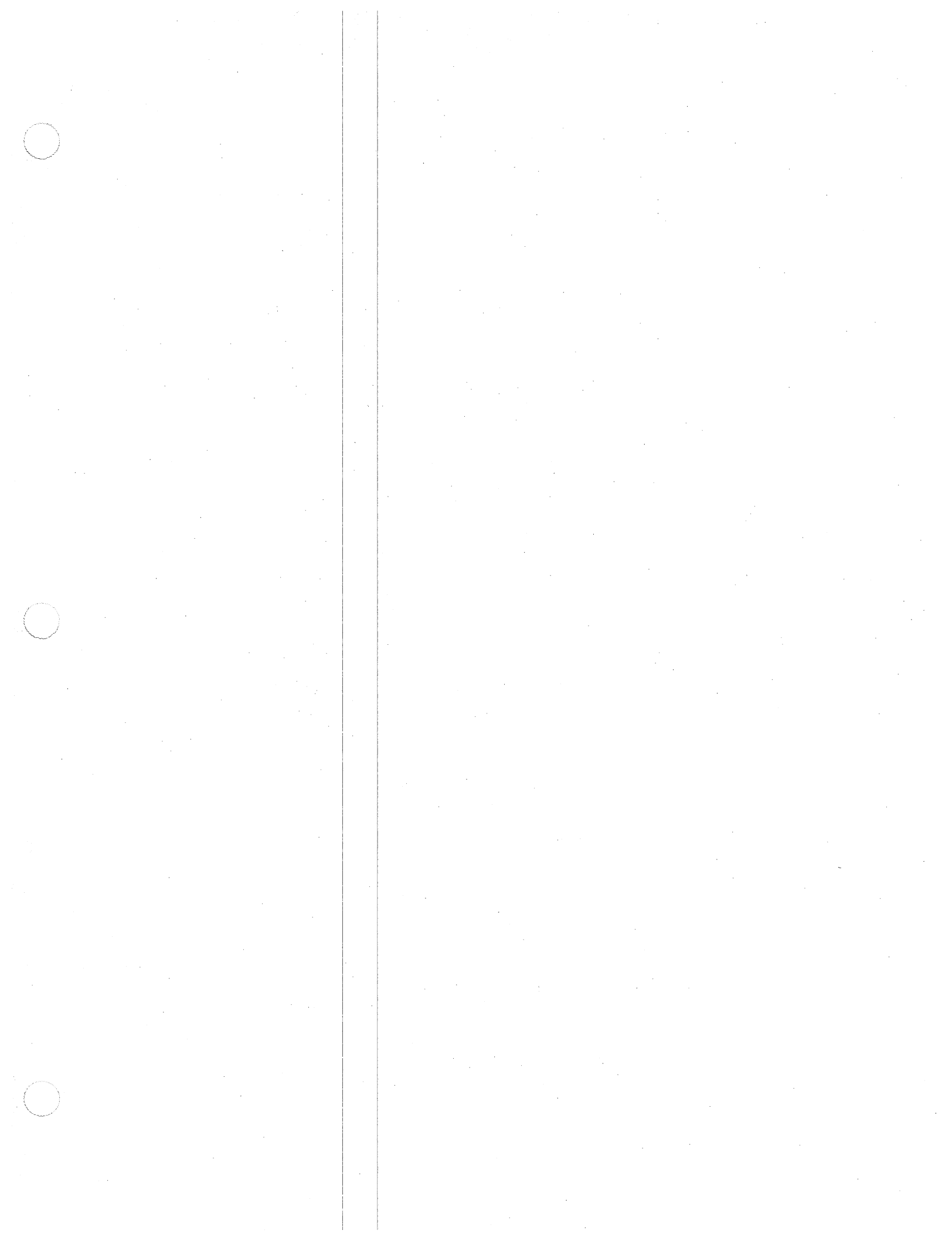

MAINTENANCE EQUIPMENT AND PROCEDURES

A. OBJECTIVES

Without maintenance, a Stormwater Management Facility (SWMF) will gradually lose all of its stormwater control capabilities. It will become unsightly, provide mosquito breeding habitats, and pose a threat to the safety of both children and adults. Ultimately, the facility will fail structurally, with potentially catastrophic impacts to downstream lives and property. In fact, the most common reported cause of SWMF failure is a lack of adequate maintenance.

Although sound design and construction practices can minimize the required amount of SWMF maintenance, they cannot eliminate it entirely. Some degree of facility maintenance will always be necessary, and this effort will require a long term commitment of time, money, personnel, and equipment on the part of maintenance staffs and departments. Recognizing the vital importance of SWMF maintenance, as well as the difficulties that are often encountered in providing it, this Chapter of the **STORMWATER MANAGEMENT FACILITY MAINTENANCE MANUAL** presents procedures that will promote thorough, effective, and efficient maintenance operations. Specific objectives of this Chapter are:

- * To explain the purpose and importance of SWMF maintenance.
- * To provide an overview of a comprehensive SWMF maintenance program.
- * To describe various types of SWMF maintenance.
- * To present recommended SWMF maintenance practices and procedures.
- * To emphasize the importance of a personal commitment to providing thorough and effective SWMF maintenance.

B. INTENDED READERS

This Chapter of the **STORMWATER MANAGEMENT FACILITY MAINTENANCE MANUAL** is intended primarily for:

- * **Maintenance Personnel, their Supervisors and Directors, and others who have "hands on" responsibility for SWMF maintenance.**
- * **Private Owners and Public Officials** will also gain valuable insight into the nature of required maintenance tasks, as well as information useful for developing and defending maintenance budgets, staffing and equipment requests.

MAINTENANCE EQUIPMENT AND PROCEDURES

* **SWMF Planners, Designers, and Reviewers** should also find this Chapter beneficial in several ways. In addition to obtaining valuable information regarding the life costs of a proposed SWMF, they will also learn the maintenance activities normally required at a facility and the equipment necessary to perform it. This information will enable them to select SWMF sites and develop SWMF designs that will facilitate rather than hinder maintenance efforts.

C. DEFINITIONS

To simplify our discussion of SWMF maintenance, please note that the term "Stormwater Management Facility" (or SWMF) may represent a detention, retention, or infiltration facility. Each of these facility types is defined below:

Detention Facility: A SWMF which temporarily impounds runoff and discharges it through a hydraulic outlet structure to a downstream conveyance system. While a certain amount of outflow may also occur via infiltration through the surrounding soil, such amounts are negligible when compared to the outlet structure discharge rates and are, therefore, not considered in the facility's design. Since a detention facility impounds runoff only temporarily, it is normally dry during non-rainfall periods.

Infiltration Facility: A SWMF which temporarily impounds runoff and discharges it via infiltration through the surrounding soil. While an infiltration facility may also be equipped with an outlet structure to discharge impounded runoff, such discharge is normally reserved for overflow and other emergency conditions. Since an infiltration facility impounds runoff only temporarily, it is normally dry during non-rainfall periods.

Retention Facility: A SWMF which, similar to a detention facility, temporarily impounds runoff and discharges its outflow through a hydraulic structure to a downstream conveyance system. Unlike a detention facility, however, a retention facility also includes a permanent impoundment and, therefore, is normally wet, even during non-rainfall periods. Storm runoff inflows are temporarily stored above this permanent impoundment.

D. THE IMPORTANCE OF SWMF MAINTENANCE

While the actual time that a SWMF performs its design function is relatively small, it must be constantly ready to do so. This is due to the randomness of rainfall events and

MAINTENANCE EQUIPMENT AND PROCEDURES

the impracticality of inspecting the facility and performing the required maintenance immediately prior to them. This clearly demonstrates the need to have a SWMF fully operational at all times. The maintenance required to accomplish this must therefore be performed thoroughly and on a regular basis, regardless of how often the facility is called upon for stormwater management. The secret to providing this level of maintenance lies in establishing and sustaining a comprehensive, regularly scheduled maintenance program.

The positive aspects of a properly functioning SWMF are readily discernible. The flood control and water quality benefits provided by SWMFs can certainly enhance the downstream stream corridor, as well as the overall quality of life in the local community. SWMFs can also permit the continued utilization of property in the community by controlling the adverse environmental impacts of such activity. However, along with their benefits, several negative aspects of SWMFs can also be encountered. The very nature of a SWMF raises certain health, safety, and aesthetic concerns, and a lack of proper facility maintenance can quickly turn these concerns into harsh realities. One of the most significant consequences of inadequate maintenance is an increased potential for mosquito breeding.

Unfortunately, mosquito breeding habitats can easily be created in a SWMF. Due to their ability to transmit viruses and other diseases, mosquitoes must be controlled, particularly in developed areas where contact with humans and domestic animals is the greatest. Unfortunately, as can be seen, these are the very same areas where most SWMFs are constructed. All mosquitoes have four stages of development - egg, larva, pupa, and adult. The adult female lays her eggs on still bodies of water or, in some species, on moist surfaces such as mud or fallen leaves. The water bodies need only be mere inches in depth and, in a SWMF, can be found in surface depressions, scour holes, tire ruts, upstream of accumulated trash and debris, and even within discarded tires, cans, and other open containers.

Each batch the female mosquito lays may contain from 100 to 300 eggs and, depending upon the weather and her stamina, the female may repeat the process several times without mating again. Suspended by the water, the eggs quickly hatch into larvae, which then grow rapidly into pupae and then emerge as flying adult mosquitoes. It is possible for mosquitoes to complete their life cycle in 7 to 10 days, with approximately half being spent in the aquatic stage. Therefore, it can be seen that, wherever water remains still or stagnant for only 4 to 5 days, at least one generation of mosquitoes numbering upwards of several hundred can be bred from a single female. The longer the water remains stagnant, the greater the potential for mosquito breeding.

MAINTENANCE EQUIPMENT AND PROCEDURES

While effective larvaciding and other mosquito extermination techniques have been developed by the various State and County mosquito extermination commissions, such efforts are extremely labor intensive and expensive. It makes much greater sense to prevent the creation of a mosquito breeding habitat through regular SWMF maintenance efforts than to control the mosquitoes after they have bred (and the facility and homes, stores, and offices around it are constructed). The regular removal of trash and debris and the elimination of both existing and potential ponding areas from a SWMF will remove the potential breeding habitats.

In addition to their potential for mosquito breeding, SWMFs are generally characterized by ponded stormwater, earthen embankments, reinforced concrete structures, and relatively steep slopes. By their very nature, these features present a potential safety hazard to people of all ages, particularly children, during both dry and wet weather. The degree of this hazard is inversely proportional to the degree of maintenance that a SWMF receives. As the level of effective SWMF maintenance increases, the threat of injury diminishes.

So far, we have established that a primary purpose of SWMF maintenance is to keep the facility operational at all times in order to benefit from all of its positive attributes. We have also described how effective SWMF maintenance will help to minimize the potential negative aspects inherent in such structures. Finally, it is important to note that regular and effective maintenance is the only way to preserve a SWMF's aesthetic character or, in more direct terms, to keep the facility from becoming an eyesore. While unmowed grass or accumulated debris in non-critical facility areas will have little, if any, adverse effect on a SWMF's operation or safety, both can have a decidedly adverse affect on the facility's appearance.

As discussed above, SWMFs are normally constructed as part of residential, commercial, office, and industrial developments and, as such, are readily visible to people, be they residents, shoppers, or workers. While aesthetic values are highly subjective, it can be said with certainty that a poorly maintained, unsightly SWMF will have an adverse effect on the quality of those people's lives, regardless of how well the facility performs its stormwater management functions. It is important to remember that a SWMF must function as designed on relatively few occasions (i.e., during storm events). However, the people who live, work or shop nearby must co-exist with it every day. Conversely, a well maintained, attractive SWMF can improve the quality of people's lives. Finally, maintenance personnel can take pride in the creation and maintenance of an attractive SWMF. This can positively affect the quality of other work they

MAINTENANCE EQUIPMENT AND PROCEDURES

perform. Pride in workmanship in one location can often translate into more effective and productive work at another.

E. COMPREHENSIVE SWMF MAINTENANCE - AN OVERVIEW

We have now established that maintenance plays a vital role in the safe and effective operation of SWMFs. But when is that maintenance necessary? What are the specific maintenance tasks that are required? How frequently should they be performed? Are some tasks more important than others? Since every SWMF is unique in some respects, specific maintenance procedures and requirements must be determined for each individual facility. However, the steps to be followed in establishing and sustaining a successful maintenance program are similar for all facilities.

In most instances, the maintenance required at a well designed and constructed SWMF will generally not be extraordinarily difficult or complex. The majority of the maintenance should be routine and will include such tasks as grass mowing and debris removal. However, to be successful, a comprehensive SWMF maintenance program must provide more. An overview of the requirements of a comprehensive maintenance program is presented below.

A comprehensive SWMF maintenance program is comprised of several related requirements. They include:

- * Providing adequate funding, staffing, equipment, and materials.
- * Performing routine maintenance procedures on a regularly scheduled basis.
- * Performing emergency maintenance procedures and repairs in a timely manner.
- * Conducting SWMF inspections to determine both the need for and effectiveness of maintenance work.
- * Providing training and instruction to maintenance personnel and inspectors.
- * Conducting periodic program reviews and evaluations to determine the overall effectiveness of the maintenance program and the need for revised or additional maintenance procedures, personnel, and equipment.
- * Instilling pride of workmanship and a commitment to excellence in program personnel.

MAINTENANCE EQUIPMENT AND PROCEDURES

A discussion of these program requirements is presented below.

Before any successful SWMF maintenance program can be initiated, there must be adequate funding to provide the necessary personnel, equipment, and materials. Without such funding, there is little likelihood that the required maintenance will be performed. The commitment to adequate funding of SWMF maintenance should be made during the early planning stages of a facility maintenance program. Once the program has begun, a lack of adequate funding and human and material resources will quickly compound an already serious program deficiency. In addition, the time, money, and effort that was invested in the planning, design, review, and construction of a SWMF will be wasted if the funding for its maintenance is not adequate to keep the facility functioning as intended.

Funding considerations must include; staffing, equipment, and material needs; facilities for storage of materials; storage, maintenance, and replacement of equipment; training costs; administrative costs; disposal costs; and permit fees. Seasonal effects and long term capital improvements should also be considered. Finally, a method of securing emergency appropriations to deal with unforeseen problems should be developed. Information regarding typical maintenance costs and recommended financing sources and practices are presented in **Chapter Six - Cost Data and Financing Techniques**.

A comprehensive SWMF maintenance program will include two basic types of maintenance procedures. They are **Functional Maintenance**, which is required to insure the safe and effective operation of a SWMF, and **Aesthetic Maintenance**, which is necessary to maintain the visual appeal and aesthetic quality of the facility. Functional Maintenance can be further divided into two types: **Preventative** and **Corrective**. It is important to note that a successful Functional Maintenance program will emphasize regularly scheduled preventative maintenance over emergency-based corrective maintenance. It will also incorporate Aesthetic Maintenance procedures into its preventative efforts in order to achieve a balanced, cost effective program. Records should be kept of the maintenance procedures requested and performed at each facility. A complete discussion of the different types of maintenance procedures is presented below in **F. SWMF MAINTENANCE PROCEDURES**. Typical forms are included in **G. TABLES, CHECKLISTS, AND LOGS**.

In addition to the actual maintenance procedures, a SWMF inspection program should be initiated. Such a program should determine the various maintenance needs at SWMFs as well as evaluate the quality and effectiveness of the maintenance

MAINTENANCE EQUIPMENT AND PROCEDURES

being performed. The extent and frequency of inspections will vary with the type and size of facility. However, in general, a formal facility inspection should be performed on a regular basis every six months as well as after a major storm event. Informal inspections should be conducted during every visit to a SWMF by maintenance personnel and, if possible, prior to the predicted occurrence of a major storm. Examples of a SWMF Inspection Checklist and Log are presented in G. TABLES, CHECKLISTS, AND LOGS.

Once they are completed, maintenance and inspection logs should not simply be filed away. They should be periodically reviewed on a systematic basis to determine the effectiveness of the overall maintenance program. Such a review can help to establish revised schedules and procedures that will more effectively utilize the maintenance program's resources. A review of maintenance and inspection records can also help identify maintenance problems that are the result of poor SWMF planning, design, or construction. This information should then be conveyed to the people or agencies responsible for these aspects of SWMFs in order that appropriate measures can be developed and implemented. Finally, the records should be reviewed periodically to determine if the maintenance program requires any additional personnel, equipment, or materials. Such a review is best performed immediately prior to the preparation of the program's next fiscal budget.

To optimize their performance, maintenance personnel should be knowledgeable of the purpose and operation of a SWMF. In addition, they should be fully aware of the importance of facility maintenance and the consequences of its neglect. Since they are normally the most frequent visitors to a SWMF site, these people are best suited logistically to evaluate the condition and maintenance needs of a facility. A successful SWMF maintenance program will include comprehensive training of maintenance personnel in these areas to guarantee that they are also best suited technically. A training or instruction program should include maintenance and inspection techniques, proper record keeping, permit and other legal requirements, and stormwater management fundamentals. As stated above, particular attention should be given to the purpose and operation of a SWMF, the importance of thorough SWMF maintenance, and the health, safety, and other consequences of maintenance neglect.

A commitment to high performance standards and personal pride in workmanship are two intangibles that can have a powerful, positive affect on SWMF maintenance quality and productivity. The commitment to providing thorough and effective SWMF maintenance must come from the top down. If SWMF maintenance is not important to the maintenance director, it will not be important to the field personnel. Con-

MAINTENANCE EQUIPMENT AND PROCEDURES

versely, pride in workmanship begins in the field. However, it must receive encouragement from the administrative offices in order to flourish throughout the maintenance program. Finally, in order to promote and nurture these qualities and to facilitate the flow of information and ideas, an open line of communication must exist in both directions.

In summary, the key requirements of a successful SWMF maintenance program include:

- * Adequate funding, staffing, equipment, and materials.
- * Performance of routine and emergency maintenance procedures.
- * Performance of SWMF inspections.
- * Training of maintenance and inspection personnel.
- * Periodic program reviews and evaluations.
- * Pride of workmanship and a commitment to excellence.

F. SWMF MAINTENANCE PROCEDURES

The maintenance procedures normally required at SWMFs vary in complexity, frequency, and cost. Before presenting details of specific maintenance procedures, it is important to discuss the various types that must be performed.

In general, SWMF maintenance procedures can be categorized as two types: **Functional Maintenance** and **Aesthetic Maintenance**. Definitions of each type of maintenance are presented below:

Functional Maintenance: The maintenance required to keep a SWMF functional or operational at all times. Functional Maintenance includes both Preventative (routine) Maintenance and Corrective (emergency) Maintenance.

Aesthetic Maintenance: The maintenance required to enhance or maintain the visual appeal of a facility. While Aesthetic Maintenance is not required for assuring the intended operation of a SWMF, it can improve the quality of life in the community and reduce the amount of required Functional Maintenance.

As described above, Functional Maintenance can be further divided into two types: **Preventative Maintenance** and **Corrective Maintenance**. These two types of Functional Maintenance are described below:

MAINTENANCE EQUIPMENT AND PROCEDURES

Preventative Maintenance: Functional Maintenance procedures that are required to maintain a SWMF's intended operation and safe condition by preventing the occurrence of problems and malfunctions. To be effective, Preventative Maintenance should be performed on a regularly scheduled basis and includes such routine procedures as grass cutting and fertilizing, silt and debris removal, and upkeep of moving parts. Since it is performed on a regular basis, Preventative Maintenance is simpler to schedule and budget for and, ultimately, is easier and less expensive to perform than Corrective Maintenance.

Corrective Maintenance: Functional Maintenance procedures that are required to correct a problem or malfunction at a SWMF and to restore the facility's intended operation and safe condition. Based upon the severity of the problem, Corrective Maintenance must be performed on an as-needed or emergency basis and includes such procedures as structural repairs, mosquito control, and restoration of vegetated and nonvegetated linings. By its nature, Corrective Maintenance is much more difficult to schedule and budget for and, ultimately, is generally more difficult and expensive to perform than Preventative Maintenance.

Presented below are detailed descriptions of typical maintenance procedures that are generally applicable to all types of SWMFs (see facility definitions in C. above). The procedures, which are presented under the headings of Preventative, Corrective, and Aesthetic Maintenance, should be part of any comprehensive SWMF maintenance program. In addition, the primary emphasis of such a maintenance program must be on Preventative rather than Corrective Maintenance. The goal of the maintenance program should be to provide a sufficient amount of Preventative Maintenance to minimize (or entirely eliminate) any Corrective Maintenance.

Aesthetic Maintenance should also play a key role in any SWMF maintenance program. As shown below, Aesthetic Maintenance procedures can be easily incorporated into a Preventative Maintenance schedule. When performed regularly, Aesthetic Maintenance can also help reduce the required amount of both Preventative and Corrective SWMF maintenance. It will help maintain the visual appeal of a SWMF and allow it to reflect positively on the maintenance staff, owner, and community.

PREVENTATIVE MAINTENANCE PROCEDURES

The purpose of Preventative Maintenance is to assure that a SWMF remains operational and safe at all times, while minimizing the need for emergency or corrective maintenance.

MAINTENANCE EQUIPMENT AND PROCEDURES

1. Grass Cutting

A regularly scheduled program of mowing and trimming of grass at SWMFs during the growing season will help to maintain a tightly knit turf, and will also help to prevent diseases, pests and the intrusion of weeds. The actual mowing requirements of an area should be tailored to the specific site conditions, grass type, and seasonal variations in the climate. In general, grass should not be allowed to grow more than 1 to 2 inches between cuttings. Allowing the grass to grow more than this amount prior to cutting it may result in damage to the grass' growing points and limit its continued healthy growth. Agencies such as the local Soil Conservation District can provide valuable assistance in determining optimum mowing requirements.

2. Grass Maintenance

Grassed areas require periodic fertilizing, de-thatching and soil conditioning in order to maintain healthy growth. Additionally, provisions should be made to re-seed and re-establish grass cover in areas damaged by sediment accumulation, storm water flow, or other causes. Agencies such as the local Soil Conservation District can provide valuable assistance in establishing a suitable grass maintenance program.

3. Vegetative Cover

Trees, shrubs, and ground cover require periodic maintenance, including fertilizing, pruning, and pest control in order to maintain healthy growth. Agencies such as the local Soil Conservation District can be of assistance in establishing a preventative maintenance program.

4. Removal and Disposal of Trash and Debris

A regularly scheduled program of debris and trash removal from SWMFs will reduce the chance of outlet structures, trash racks and other components becoming clogged and inoperable during storm events. Additionally, removal of trash and debris will prevent possible damage to vegetated areas and eliminate potential mosquito breeding habitats. Disposal of debris and trash must comply with all local, county, state, and federal waste flow control regulations. Only suitable disposal and recycling sites should be utilized. Agencies such as the Division of Solid Waste Management of the New Jersey Department of Environmental Protec-

MAINTENANCE EQUIPMENT AND PROCEDURES

tion should be contacted for information on disposal regulations.

5. Sediment Removal and Disposal

Accumulated sediment should be removed before it threatens the operation or storage volume of a SWMF. Disposal of sediment must comply with all local, county, state, and federal regulations. Only suitable disposal sites should be utilized. The sediment removal program in infiltration facilities must also include provisions for monitoring the porosity of the sub-base, and replacement or cleansing of the pervious materials as necessary. Agencies such as the Division of Solid Waste Management of the New Jersey Department of Environmental Protection should be contacted for information on disposal regulations.

6. Mechanical Components

SWMF components, such as valves, sluice gates, pumps, fence gates, locks, and access hatches, should remain functional at all times. Regularly scheduled maintenance should be performed in accordance with the manufacturers' recommendations. Additionally, all mechanical components should be operated at least once every three months to assure their continued performance.

7. Elimination of Potential Mosquito Breeding Habitats

The most effective mosquito control program is one that eliminates potential breeding habitats. Almost any stagnant pool of water can be attractive to mosquitoes, and the source of a large mosquito population. Ponded water in areas such as open cans and bottles, debris and sediment accumulations, and areas of ground settlement provide ideal locations for mosquito breeding. A maintenance program dedicated to eliminating potential breeding areas is certainly preferable to controlling the health and nuisance effects of flying mosquitoes. The local Mosquito Control Commission can provide valuable information on establishing this maintenance program.

8. Pond Maintenance

A program of monitoring the aquatic environment of a permanent pond should be established. Although the complex environment of a healthy aquatic ecosystem will require little maintenance, water quality, aeration, vegetative growth, and animal populations should be monitored on a reg-

MAINTENANCE EQUIPMENT AND PROCEDURES

ular basis. The timely correction of an imbalance in the ecosystem can prevent more serious problems from occurring. Additional information on pond maintenance can be obtained through agencies such as the U.S. Fish and Wildlife Service.

9. Inspection

Regularly scheduled inspections of the facility should be performed by qualified inspectors. The primary purpose of the inspections is to ascertain the operational condition and safety of the facility, particularly the condition of embankments, outlet structures, and other safety-related aspects. Inspections will also provide information on the effectiveness of regularly scheduled Preventative and Aesthetic Maintenance procedures, and will help to identify where changes in the extent and scheduling of the procedures are warranted. Finally, the facility inspections should also be used to determine the need for and timing of Corrective Maintenance procedures. It should be noted that, in addition to regularly scheduled inspections, an informal inspection should be performed during every visit to a SWMF by maintenance or supervisory personnel. A sample SWMF inspection checklist is included in G. TABLES, CHECKLISTS, AND LOGS. Additional information on dam inspections can be found in the State of New Jersey's Dam Safety Manual published by the N.J. Department of Environmental Protection.

10. Reporting

The recording of all maintenance work and inspections provide valuable data on the facility condition. Review of this information will also help to establish more efficient and beneficial maintenance procedures and practices. Along with the written reports, a chain of command for reporting and solving maintenance problems and addressing maintenance needs should be established. From field personnel to the maintenance director, everyone should be encouraged to report any problems or suggest any changes to the maintenance program. Samples of SWMF maintenance and inspection checklists and logs are included in G. TABLES, CHECKLISTS, AND LOGS.

CORRECTIVE MAINTENANCE PROCEDURES

Corrective Maintenance is required on an emergency or non-routine basis to correct problems or malfunctions and to restore the intended operation and safe condition of a SWMF.

MAINTENANCE EQUIPMENT AND PROCEDURES

1. Removal of Debris and Sediment

Sediment, debris and trash which threatens the discharge capacity of a SWMF should be removed immediately and properly disposed of in a timely manner. Equipment and personnel must be available to perform the removal work on short notice. The lack of an available disposal site should not delay the removal of trash, debris, and sediment. Temporary disposal sites should be utilized if necessary.

2. Structural Repairs

Structural damage to outlet and inlet structures, trash racks, and headwalls from vandalism, flood events, or other causes must be repaired promptly. Equipment, materials and personnel must be available to perform these repairs on short notice. The immediacy of the repairs will depend upon the nature of the damage and its effects on the safety and operation of the facility. The analysis of structural damage and the design and performance of structural repairs should only be undertaken by qualified personnel.

3. Dam, Embankment, and Slope Repairs

Damage to dams, embankments, and side slopes must be repaired promptly. This damage can be the result of rain or flood events, vandalism, animals, vehicles, or neglect. Typical problems include settlement, scouring, cracking, sloughing, seepage, and rutting. Equipment, materials and personnel must be available to perform these repairs on short notice. The immediacy of the repairs will depend upon the nature of the damage and its effects on the safety and operation of the facility. The analysis of damage and the design and performance of geotechnical repairs should only be undertaken by qualified personnel.

4. Dewatering

It may be necessary to remove ponded water from within a malfunctioning SWMF. This ponding may be the result of a blocked principal outlet (detention facility), inoperable low level outlet (retention facility), loss of infiltration capacity (infiltration facility), or poor bottom drainage. Portable pumps may be necessary to remove the ponded water temporarily until a permanent solution can be implemented.

MAINTENANCE EQUIPMENT AND PROCEDURES

5. Pond Maintenance

Problems such as algae growth, excessive siltation, and mosquito breeding, should be addressed and corrected in a timely manner. The sooner the problem is corrected, the easier it will be to restore a balanced environment in the pond. Due to the complex environment in a pond, it is recommended that agencies such as the U.S. Fish and Wildlife Service be consulted for corrective maintenance procedures.

6. Extermination of Mosquitoes

If neglected, a SWMF can readily become an ideal mosquito breeding area. Extermination of mosquitoes will usually require the services of an expert, such as the local Mosquito Extermination Commission. Proper procedures carried out by trained personnel can control the mosquitoes with a minimum of damage or disturbance to the environment. If mosquito control in a facility becomes necessary, the preventative maintenance program should also be re-evaluated, and more emphasis placed on control of mosquito breeding habitats.

7. Erosion Repair

Vegetative cover or other protective measures are necessary to prevent the loss of soil from the erosive forces of wind and water. Where a re-seeding program has not been effective in maintaining a non-erosive vegetative cover, or other factors have exposed soils to erosion, corrective steps should be initiated to prevent further loss of soil and any subsequent danger to the stability of the facility. Soil loss can be controlled by a variety of materials and methods, including riprap, gabion lining, sod, seeding, concrete lining and re-grading. The local Soil Conservation District can provide valuable assistance in recommending materials and methodologies to control erosion.

8. Fence Repair

Fences are damaged by many factors, including vandalism and storm events. Timely repair will maintain the security of the site.

9. Elimination of Trees, Brush, Roots and Animal Burrows

The stability of dams, embankments, and side slopes can be impaired by large roots and animal burrows. Additionally, burrows can present a safety hazard for maintenance personnel. Trees and brush with extensive, woody root systems

MAINTENANCE EQUIPMENT AND PROCEDURES

should be completely removed from dams and embankments to prevent their destabilization and the creation of seepage routes. Roots should also be completely removed to prevent their decomposition within the dam or embankment. Root voids and burrows should be plugged by filling with material similar to the existing material, and capped just below grade with stone, concrete or other material. If plugging of the burrows does not discourage the animals from returning, further measures should be taken to either remove the animal population or to make critical areas of the facility unattractive to them.

10. Snow and Ice Removal

Accumulations of snow and ice can threaten the functioning of a SWMF, particularly at inlets, outlets, and emergency spillways. Providing the equipment, materials and personnel to monitor and remove snow and ice from these critical areas is necessary to assure the continued functioning of the facility during the winter months.

AESTHETIC MAINTENANCE PROCEDURES

Aesthetic Maintenance, although not required to keep a SWMF operational, will maintain the visual appeal of a facility and will benefit everyone within the local community. This is particularly true for those SWMFs that are also used by members of the community for athletic and recreational purposes. Aesthetic Maintenance can also reduce the amount of required Preventative and Corrective Maintenance. A comparison of Aesthetic and Preventative Maintenance procedures reveals how both can readily be combined into an overall SWMF maintenance program.

1. Graffiti Removal

The timely removal of this obvious eyesore will restore the aesthetic quality of a SWMF. Removal can be accomplished by painting or otherwise covering it, or removing it with scrapers, solvents or cleansers. Timely removal is important to discourage further graffiti and other acts of vandalism.

2. Grass Trimming

Although time consuming, trimming of grass edges around structures and fences will provide for a neat and attractive appearance of the facility.

MAINTENANCE EQUIPMENT AND PROCEDURES

3. Control of Weeds

Although a regular grass maintenance program will keep weed intrusion to a minimum, some weeds will invariably appear. Periodic weeding, either chemically or mechanically, will not only help to maintain a healthy turf, but will also keep grassed areas looking attractive.

4. Details

Careful, meticulous, and frequent attention to the performance of maintenance items such as painting, tree pruning, leaf collection, debris removal, and grass cutting will result in a SWMF that remains both functional and attractive.

G. TABLES, CHECKLISTS, AND LOGS

Included in this Chapter are Tables and sample Checklists and Logs regarding various aspects of SWMF maintenance and inspection. They include:

TABLE 4-1 - SUMMARY OF MAINTENANCE PROCEDURES is a listing of the maintenance procedures described in detail in the above text.

TABLE 4-2 - MAINTENANCE EQUIPMENT AND MATERIALS presents a comprehensive list of equipment and materials typically required for SWMF maintenance.

TABLE 4-3 - MAINTENANCE WORK ORDER AND CHECKLIST is a comprehensive form for recording both required and completed maintenance work.

TABLE 4-4 - MAINTENANCE LOG provides a summary table for recording of all maintenance work at an individual SWMF.

TABLE 4-5 - INSPECTION CHECKLIST provides a comprehensive checklist of inspection items for use by SWMF inspectors.

TABLE 4-6 - INSPECTION LOG provides a summary table for recording the results of all inspections of an individual SWMF.

The reader should note that the information presented in the sample Checklists and Logs have been prepared for a "typical" SWMF. Appropriate revisions should be made to adapt this information to the requirements of a specific maintenance program or facility.

MAINTENANCE EQUIPMENT AND PROCEDURES

TABLE 4-1

N.J. DEPARTMENT OF ENVIRONMENTAL PROTECTION STORMWATER MANAGEMENT FACILITY MAINTENANCE MANUAL

SUMMARY OF MAINTENANCE PROCEDURES

A. PREVENTATIVE MAINTENANCE

1. Grass Cutting
2. Grass Maintenance
3. Vegetative Cover
4. Removal and Disposal of Trash and Debris
5. Sediment Removal and Disposal
6. Mechanical Components
7. Elimination of Mosquito Breeding Habitats
8. Pond Maintenance
9. Inspection
10. Reporting

B. CORRECTIVE MAINTENANCE

1. Removal of Debris and Sediment
2. Structural Repairs
3. Dam, Embankment, and Slope Repairs
4. Dewatering
5. Pond Maintenance
6. Extermination of Mosquitoes
7. Erosion Repair
8. Fence Repair
9. Elimination of Trees, Brush, Roots, and Animal Burrows
10. Snow and Ice Removal

C. AESTHETIC MAINTENANCE

1. Graffiti Removal
2. Grass Trimming
3. Control of Weeds
4. Details

MAINTENANCE EQUIPMENT AND PROCEDURES

TABLE 4-2

N.J. DEPARTMENT OF ENVIRONMENTAL PROTECTION STORMWATER MANAGEMENT FACILITY MAINTENANCE MANUAL

MAINTENANCE EQUIPMENT AND MATERIALS

This Table lists the equipment and materials which are typically required to maintain a SWMF. It is presented as a general guide to assist owners, maintenance directors, designers, and financial planners in establishing specific facility maintenance programs. The reader should note that actual equipment and materials requirements must be determined on an individual basis for each facility. Additionally, specific manufacturers, brand names, and types of equipment are not included, as availability, personal preference, and specific usage must also be determined for each maintenance program.

A. GRASS MAINTENANCE EQUIPMENT

1. Tractor-Mounted Mowers
2. Riding Mowers
3. Hand Mowers
4. Gas Powered Trimmers
5. Gas Powered Edgers
6. Seed Spreaders
7. Fertilizer Spreaders
8. De-Thatching Equipment
9. Pesticide and Herbicide Application Equipment
10. Grass Clipping and Leaf Collection Equipment

B. VEGETATIVE COVER MAINTENANCE EQUIPMENT

1. Saws
2. Pruning Shears
3. Hedge Trimmers
4. Wood Chippers

C. TRANSPORTATION EQUIPMENT

1. Trucks for Transportation of Materials
2. Trucks for Transportation of Equipment
3. Vehicles for Transportation of Personnel

MAINTENANCE EQUIPMENT AND PROCEDURES

TABLE 4-2 (CONTINUED)

D. DEBRIS, TRASH, AND SEDIMENT REMOVAL EQUIPMENT

1. Loader
2. Backhoe
3. Grader

E. MISCELLANEOUS EQUIPMENT

1. Shovels
2. Rakes
3. Picks
4. Wheel Barrows
5. Fence Repair Tools
6. Painting Equipment
7. Gloves
8. Standard Mechanics Tools
9. Tools for Maintenance of Equipment
10. Office Space
11. Office Equipment
12. Telephones
13. Safety Equipment
14. Tools for Concrete Work (Mixers, Form Materials, etc.)
15. Welding Equipment (for Repair of Trash Racks, etc.)

F. MATERIALS

1. Topsoil
2. Fill
3. Seed
4. Soil Amenities (Fertilizer, Lime, etc.)
5. Chemicals (Pesticides, Herbicides, etc.)
6. Mulch
7. Paint
8. Paint Removers (for Graffiti)
9. Spare Parts for Equipment
10. Oil and Grease for Equipment and SWMF Components
11. Concrete

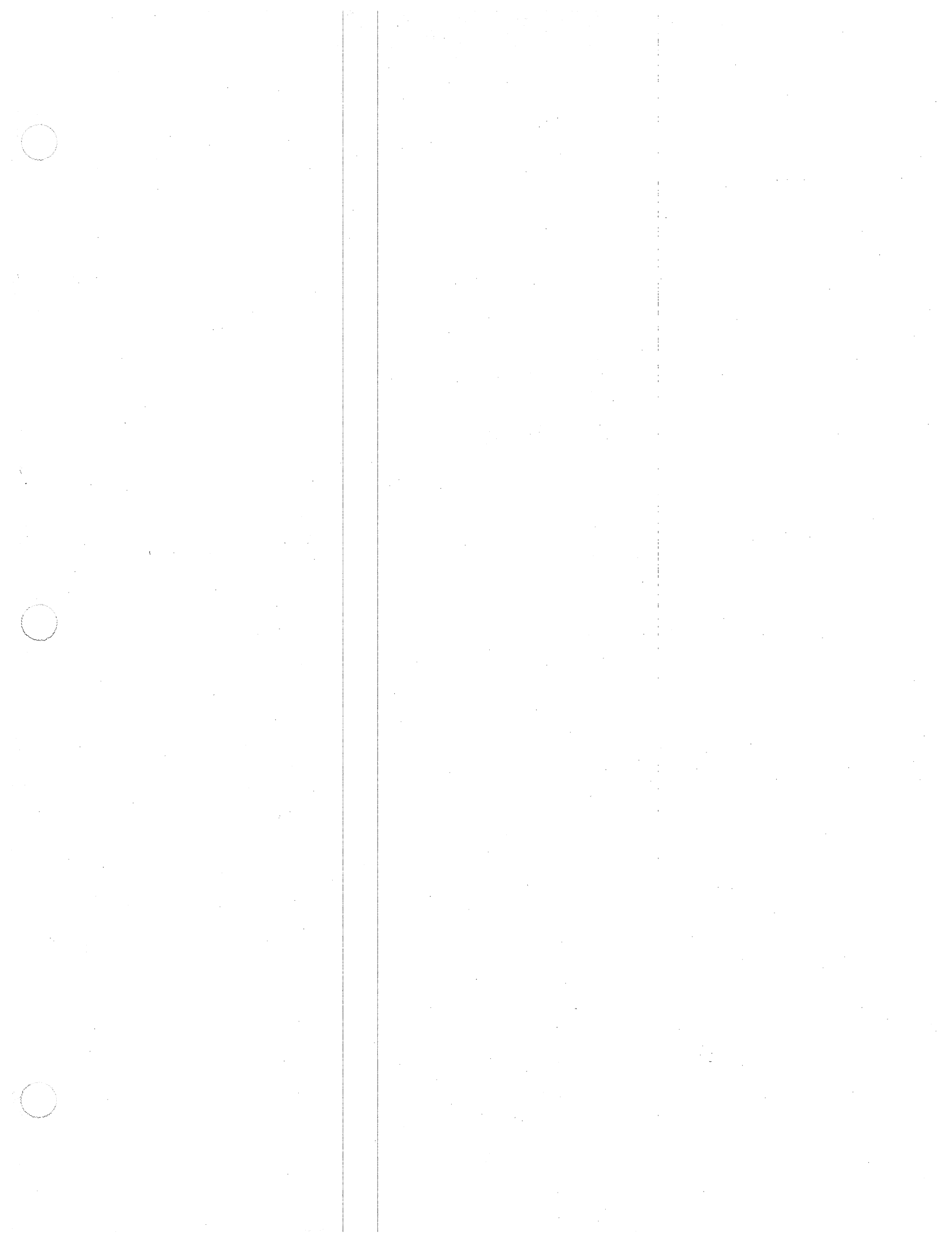

Maintenance Work Order and Checklist for Stormwater Management Facilities

Name of Facility: _____

Location: _____ Date: _____

Crew: _____ Work Started: date _____ time _____

Equipment: _____ Work Completed: date _____ time _____

Weather: _____ Total Manhours of Work: _____

A. Preventative Maintenance

Work Item	Items Required (√)	Items Done (√)	Comments and Special Instructions
1. Grass Cutting			
A. Bottoms			
B. Embankments and Side Slopes			
C. Perimeter Areas			
D. Access Areas and Roads			
E. Other:			
2. Grass Maintenance			
A. Fertilizing			
B. Re-Seeding			
C. De-Thatching			
D. Pest Control			
E. Other:			
3. Vegetative Cover			
A. Fertilizing			
B. Pruning			
C. Pest Control			
D. Other:			
4. Trash and Debris Removal			
A. Bottoms			
B. Embankments and Side Slopes			
C. Perimeter Areas			
D. Access Areas and Roads			
E. Inlets			
F. Outlets and Trash Racks			
G. Other:			
5. Sediment Removal			
A. Inlets			
B. Outlets and Trash Racks			
C. Bottoms			
D. Other:			

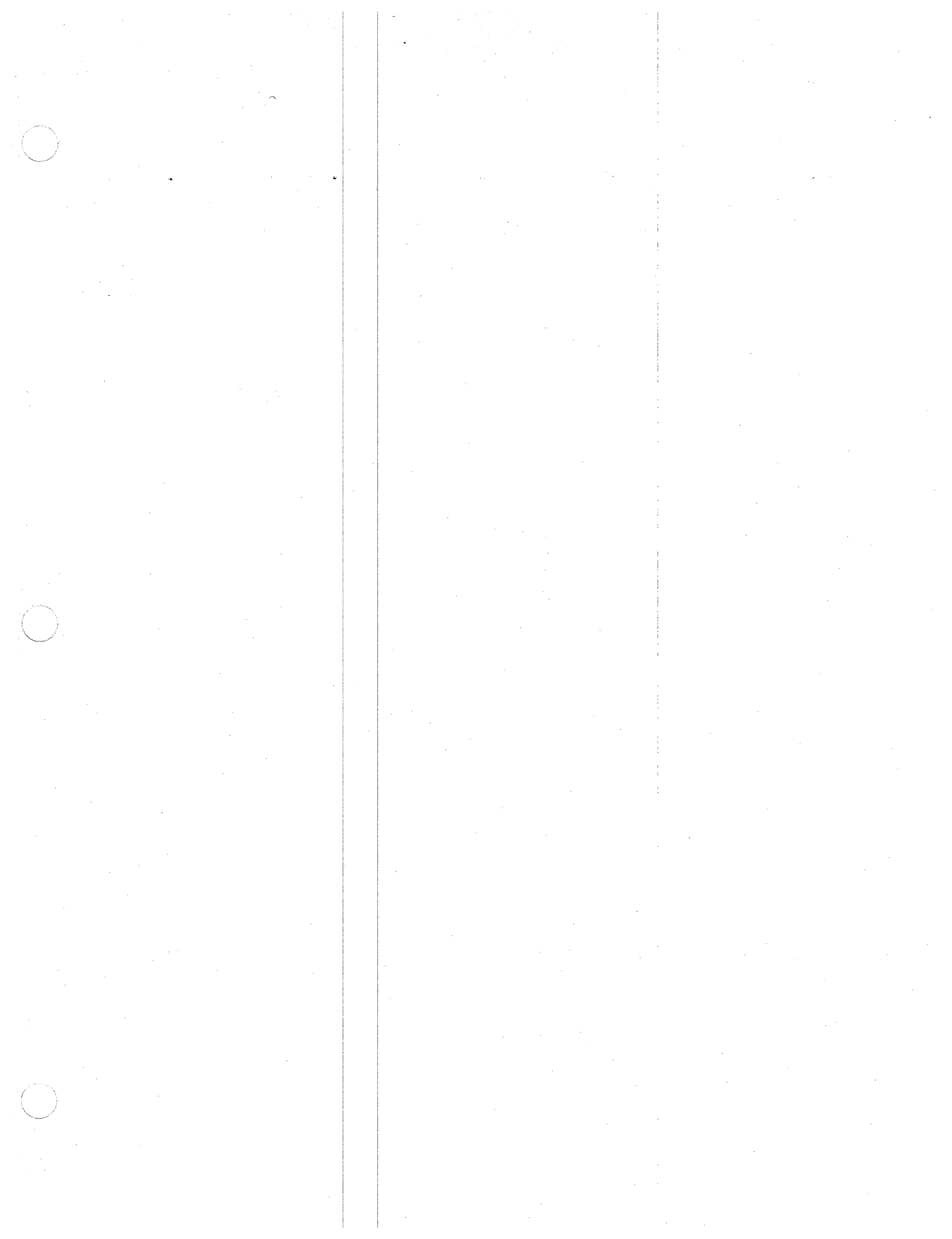

Work Item

Items
Required
(√)

Items
Done
(√)

Comments and Special Instructions

6. Mechanical Components

A. Valves			
B. Sluice Gates			
C. Pumps			
D. Fence Gates			
E. Locks			
F. Access Hatches			
G. Other:			

7. Elimination of Potential Mosquito Breeding Habitats

--	--	--	--

8. Pond Maintenance

A. Aeration Equipment			
B. Debris & Trash Removal			
C. Weed Removal			
D. Other:			

9. Other Preventative Maintenance

A.			
B.			
C.			

B. Corrective Maintenance

Work Item

Items
Required
(√)

Items
Done
(√)

Location, Comments and Special Instructions

1. Removal of Debris & Sediment

--	--	--

2. Structural Repairs

--	--	--

3. Dam, Embankment & Slope Repairs

--	--	--

4. Dewatering

--	--	--

5. Pond Maintenance

--	--	--

6. Control of Mosquitoes

--	--	--

7. Erosion Repair

--	--	--

8. Fence Repair

--	--	--

9. Elimination of Trees, Brush, Roots & Animal Burrows

--	--	--

10. Snow & Ice Removal

--	--	--

11. Other

--	--	--



C. Aesthetic Maintenance

Work Item	Items Required (√)	Items Done (√)	Location & Comments
1. Graffiti Removal			
2. Grass Trimming			
3. Weeding			
4. Other:			

Remarks (Refer to Item No., If Applicable):

Work Order Prepared By: _____

Work Completed By: _____







C. Aesthetic Maintenance

Work Item

1. Graffiti Removal

--	--	--	--	--	--	--	--	--	--

2. Grass Trimming

--	--	--	--	--	--	--	--	--	--

3. Weeding

--	--	--	--	--	--	--	--	--	--

4. Other:

--	--	--	--	--	--	--	--	--	--

Remarks (Refer to Item No., If Applicable):



Table 4-5

**Inspection Checklist
for
Stormwater Management Facilities**

Name of Facility: _____

Location: _____ Date: _____

Weather: _____

Facility Item	O.K. ¹	Routine ²	Urgent ³	Comments ⁴
1. Embankments and Side Slopes				
A. Vegetation				
B. Linings				
C. Erosion				
D. Settlement				
E. Sloughing				
F. Trash and Debris				
G. Seepage				
H. Aesthetics				
I. Other:				

2. Bottoms (Detention and Infiltration)				
A. Vegetation				
B. Erosion				
C. Standing Water				
D. Settlement				
E. Trash and Debris				
F. Sediment				
G. Aesthetics				
H. Other:				

3. Low Flow Channels (Detention)				
A. Vegetation				
B. Linings				
C. Erosion				
D. Settlement				
E. Standing Water				
F. Trash and Debris				
G. Sediment				
H. Other:				

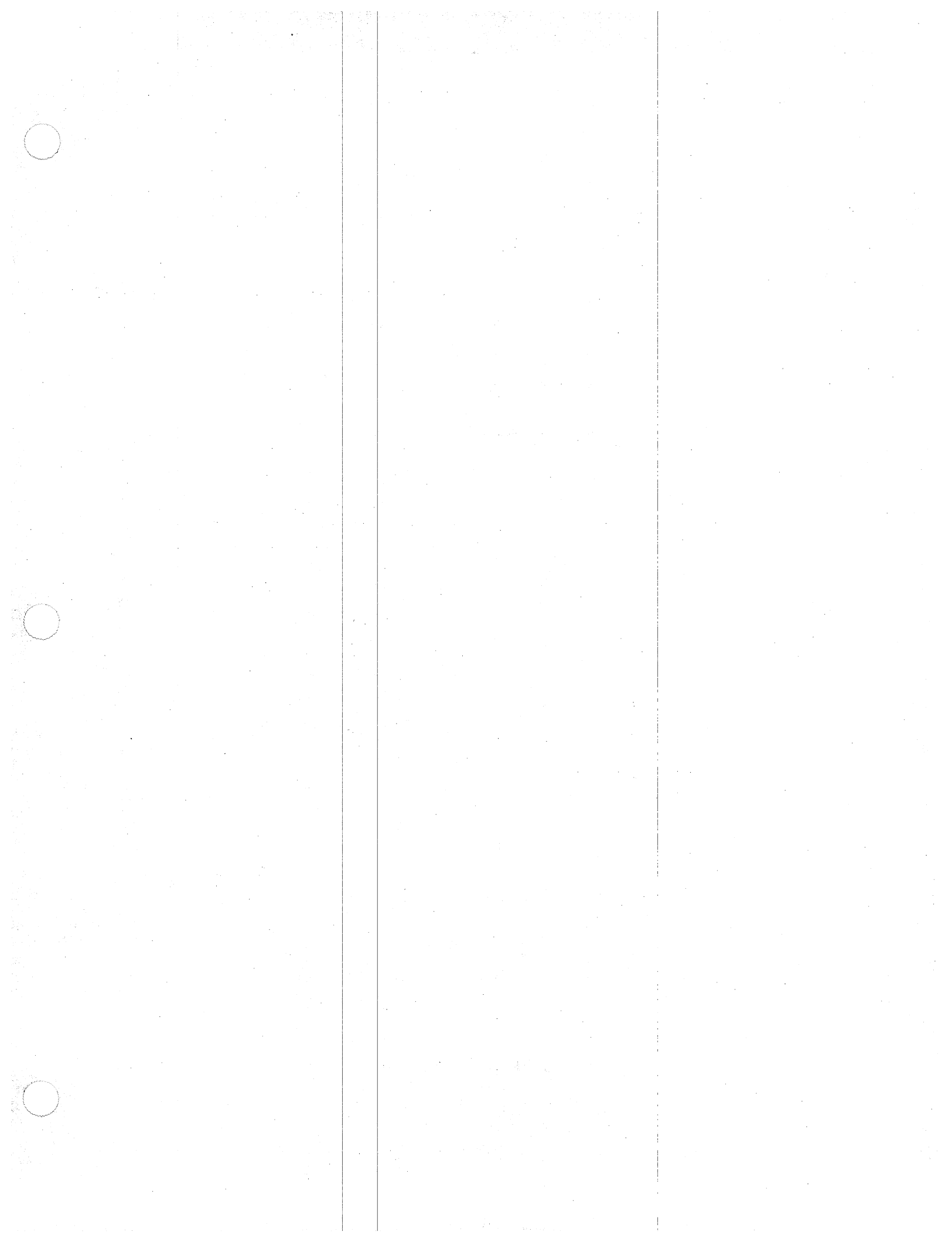

Facility Item

O.K.¹ Routine² Urgent³ Comments⁴

4. Ponds (Retention)

A. Vegetation				
B. Shoreline Erosion				
C. Aeration Equipment				
D. Trash & Debris				
E. Sediment				
F. Water Quality				
G. Other:				

5. Inlet Structure

A. Condition of Structure				
B. Erosion				
C. Trash & Debris				
D. Sediment				
E. Aesthetics				
F. Other:				

6. Outlet Structure (Detention & Retention)

A. Condition of Structure				
B. Erosion				
C. Trash & Debris				
D. Sediment				
E. Mechanical Components				
F. Aesthetics				
G. Other:				

7. Emergency Spillway

A. Vegetation				
B. Lining				
C. Erosion				
D. Trash & Debris				
E. Other:				

8. Perimeter

A. Vegetation				
B. Erosion				
C. Trash & Debris				
D. Fences & Gates				
E. Aesthetics				
F. Other:				

9. Access Roads

A. Vegetation				
B. Road Surface				
C. Fence & Gates				
D. Erosion				
E. Aesthetics				
F. Other:				

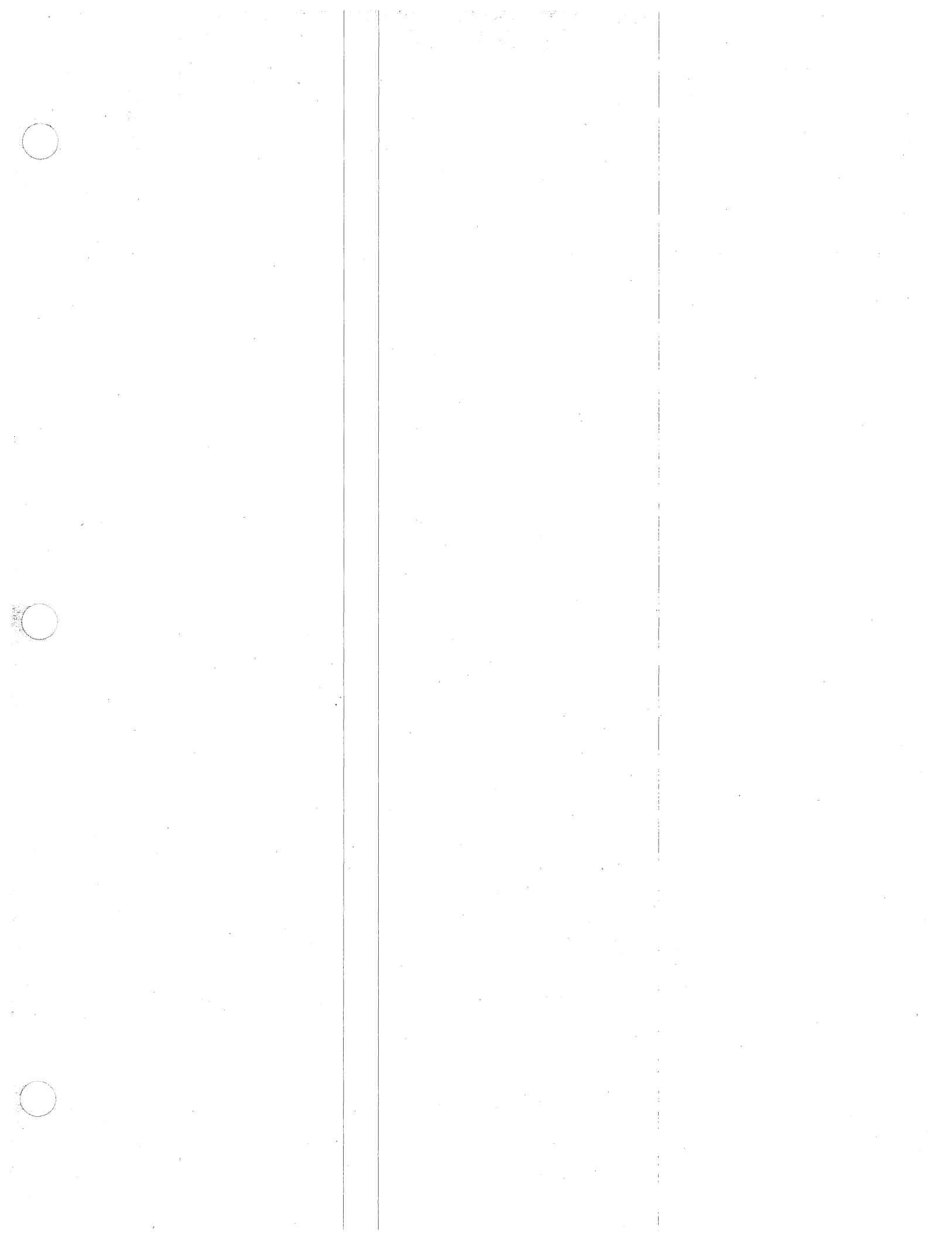

Facility Item

O.K.¹ Routine² Urgent³ Comments⁴

10. Miscellaneous

Facility Item	O.K. ¹	Routine ²	Urgent ³	Comments ⁴
A. Effectiveness of Exist. Maint. Program				
B. Dam Inspections				
C. Potential Mosquito Habitats				
D. Mosquitoes				
E.				
F.				
G.				

¹ The item checked is in good condition, and the maintenance program is adequate.

² The item checked requires attention, but does not present an immediate threat to the facility function or other facility components.

³ The item checked requires immediate attention to keep the facility operational or to prevent damage to other facility components.

⁴ Provide explanation and details if columns 2 or 3 are checked.

Remarks (Refer to Item No., If Applicable):

Inspector: _____



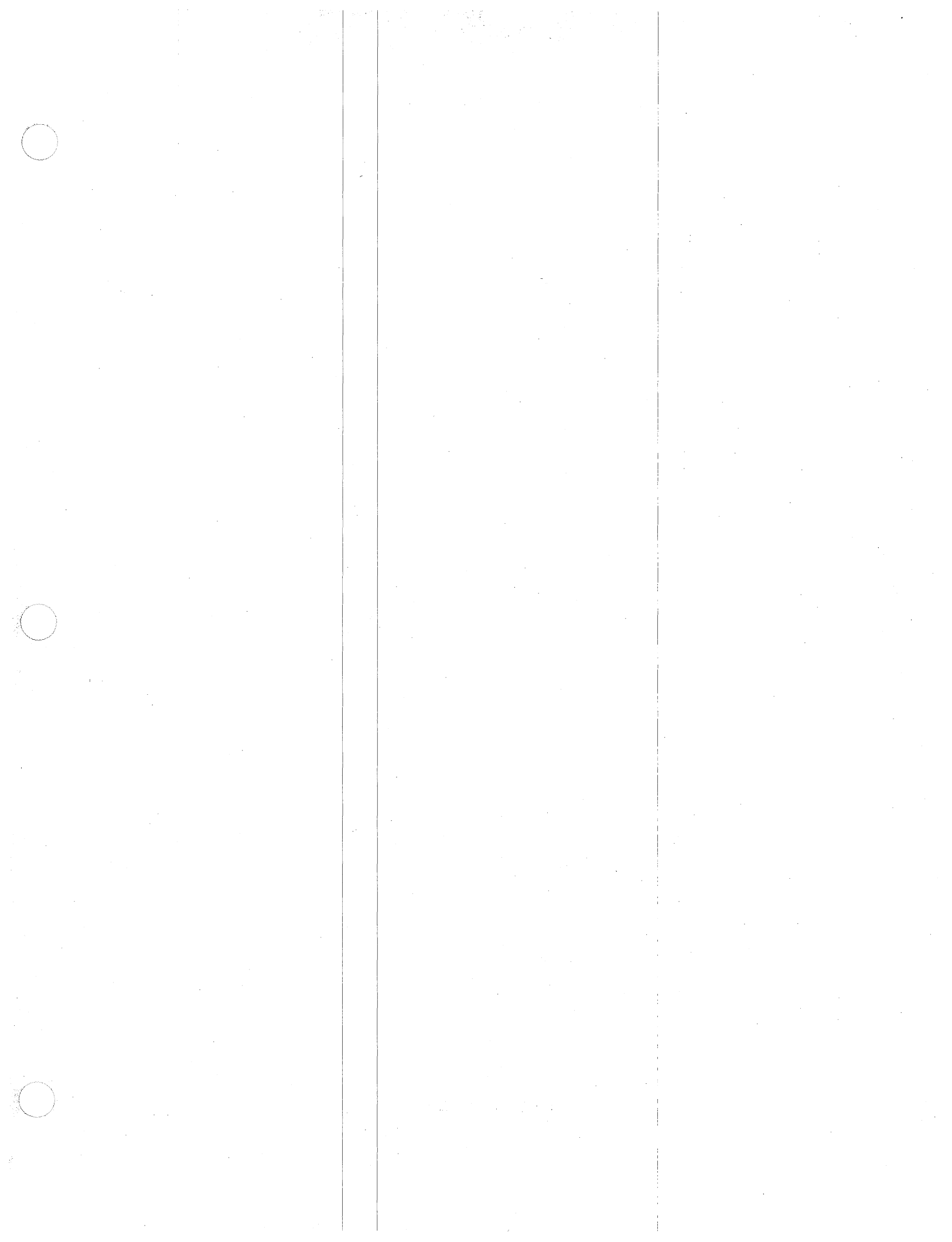



Facility Item

10. **Miscellaneous**

A. Effectiveness of Exist. Maint. Program											
B. Dam Inspections											
C. Potential Mosquito Habitats											
D. Mosquitoes											
E.											
F.											
G.											

- ¹ The item checked is in good condition, and the maintenance program is adequate.
- ² The item checked requires attention, but does not present an immediate threat to the facility function or other facility components.
- ³ The item checked requires immediate attention to keep the facility operational or to prevent damage to other facility components.

Remarks (Refer to Item No., If Applicable):

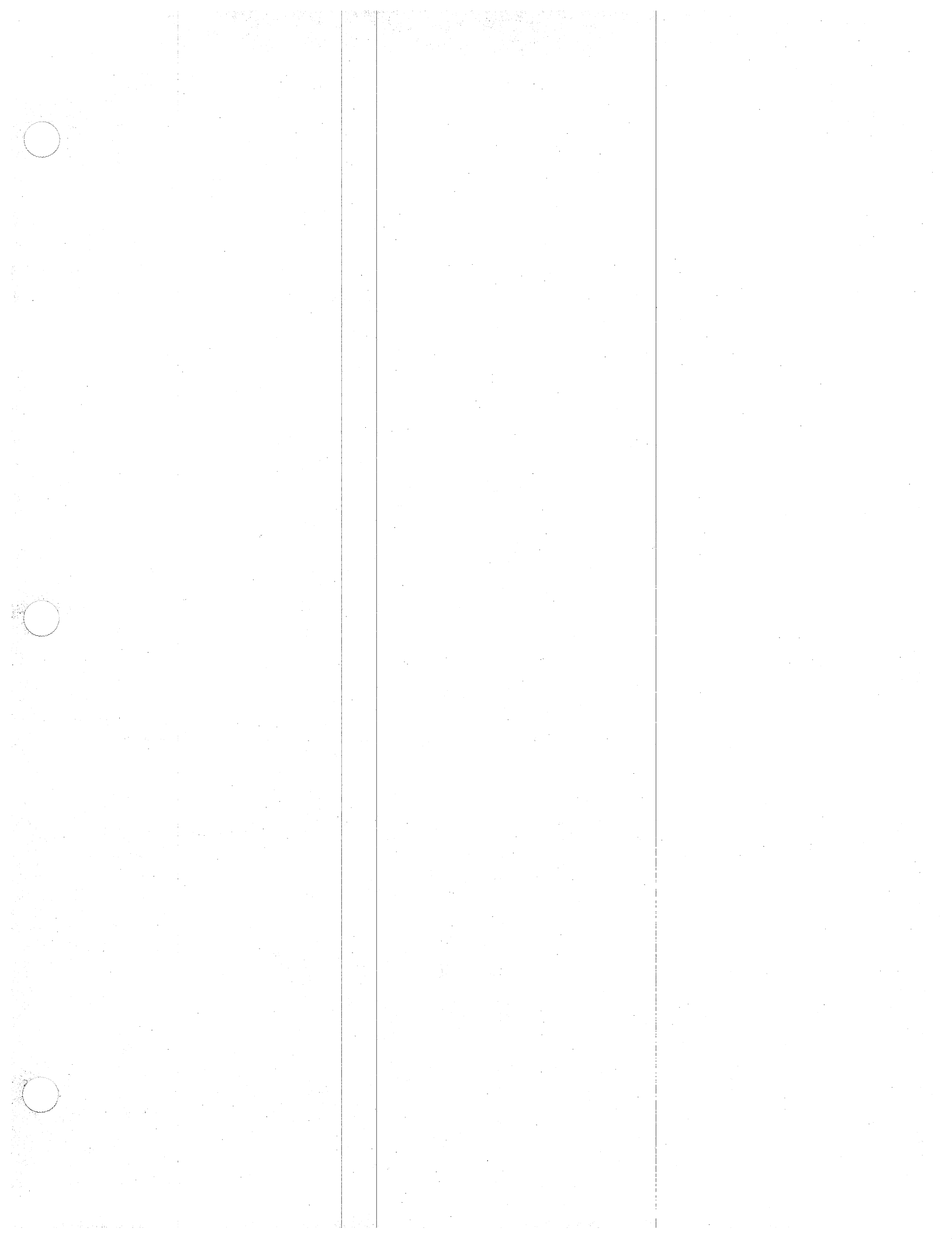

**NEW JERSEY
DEPARTMENT OF ENVIRONMENTAL PROTECTION
STORMWATER MANAGEMENT FACILITIES
MAINTENANCE MANUAL**

**CHAPTER FIVE
REGULATORY ASPECTS**

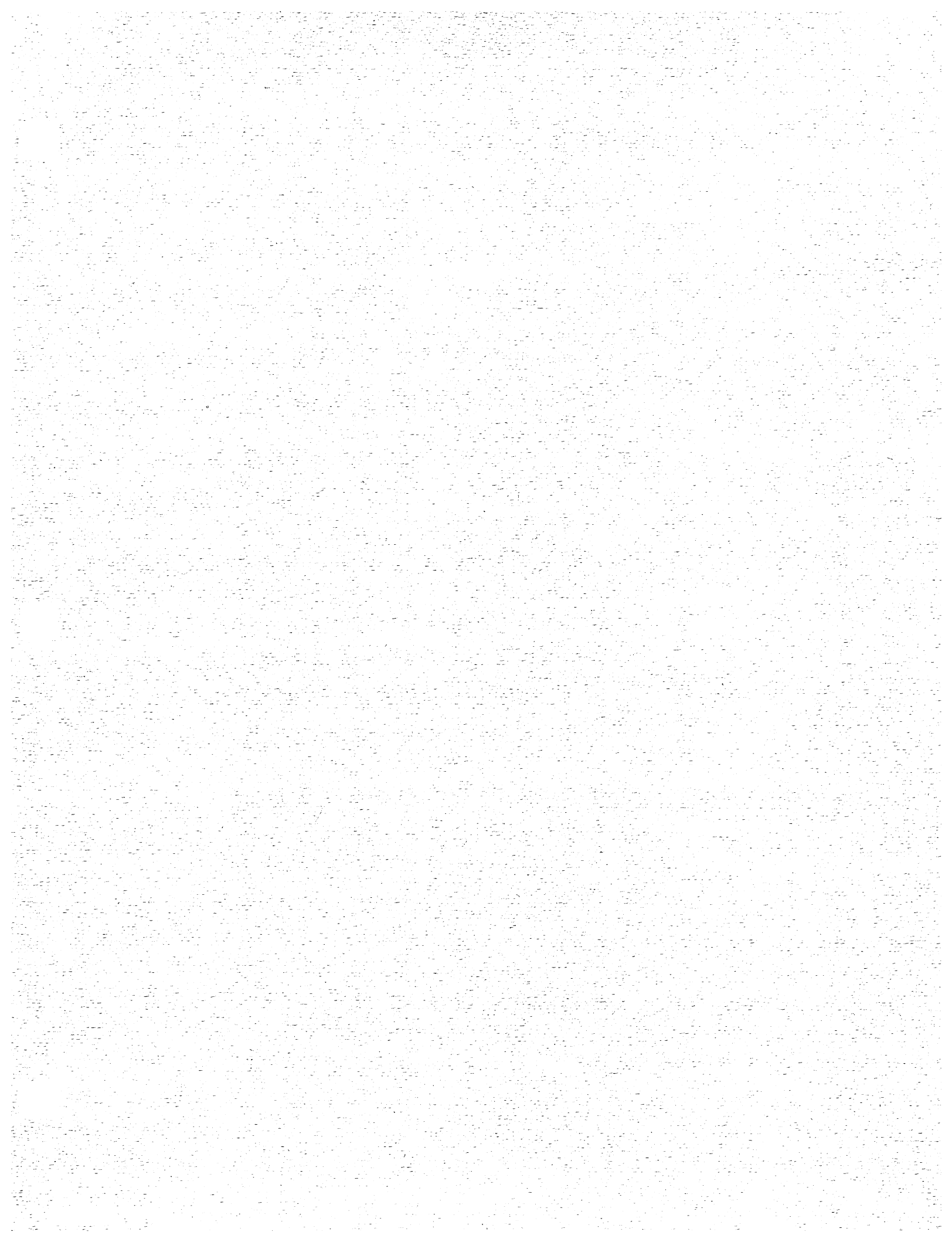

N.J. DEPARTMENT OF ENVIRONMENTAL PROTECTION
STORMWATER MANAGEMENT FACILITIES MAINTENANCE MANUAL

CHAPTER FIVE - REGULATORY ASPECTS

TABLE OF CONTENTS

A. OBJECTIVES	REG-1
B. INTENDED READERS	REG-1
C. THE ROLE OF THE REGULATOR IN SWMF MAINTENANCE	REG-2
D. SWMF REVIEW AND APPROVAL PROGRAMS	REG-4
E. SWMF CONSTRUCTION INSPECTION PROGRAMS	REG-6
F. SWMF MAINTENANCE INSPECTION PROGRAMS	REG-8
G. PUBLIC ASSUMPTION OF SWMF MAINTENANCE	REG-10

TABLE 5-1 SAMPLE SWMF MAINTENANCE ORDINANCE	REG-13
---	--------

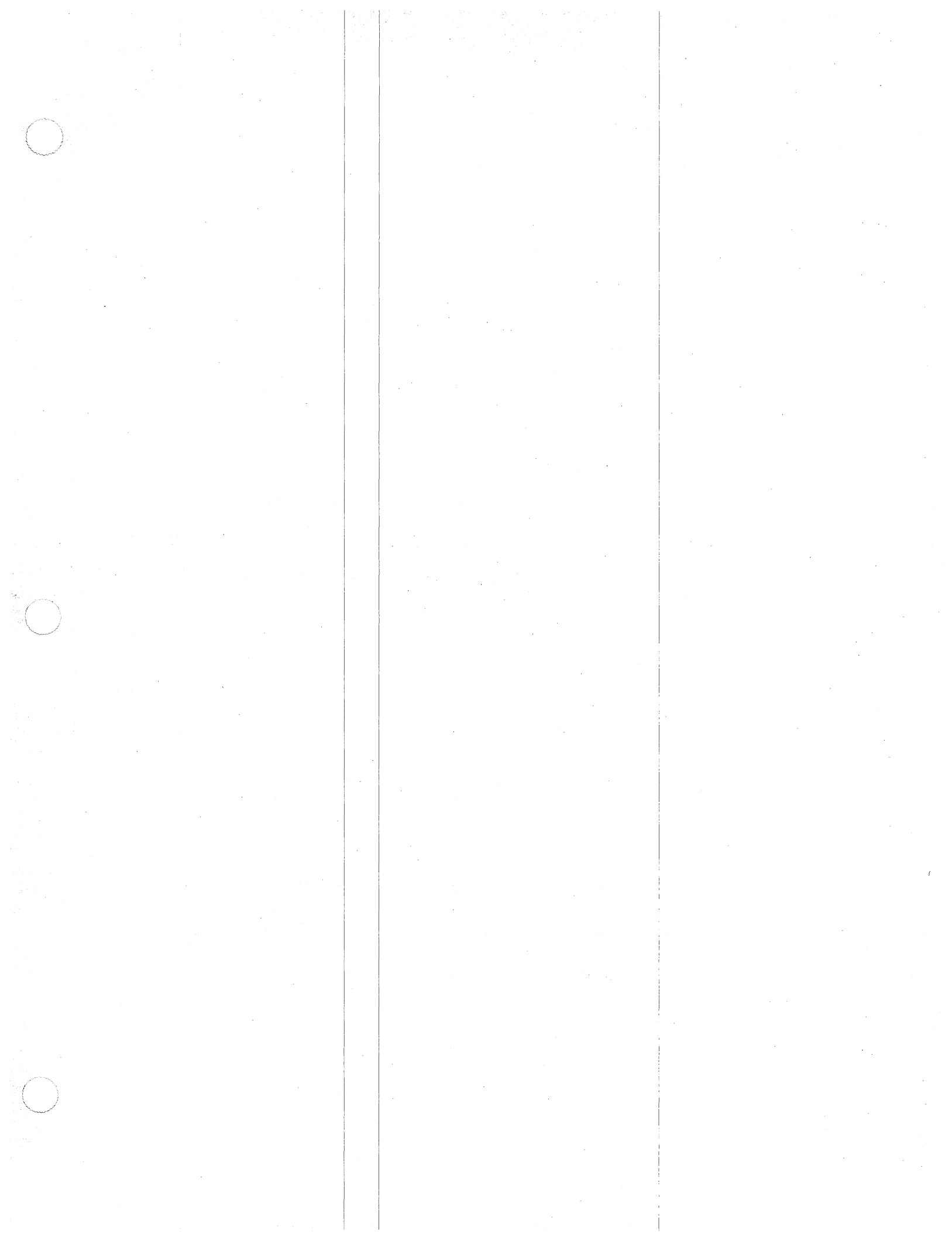

REGULATORY ASPECTS

A. OBJECTIVES

As described throughout the **STORMWATER MANAGEMENT FACILITIES MAINTENANCE MANUAL**, the effective and efficient maintenance of a Stormwater Management Facility (or **SWMF**) not only depend upon the actual maintenance performed at the site, but also upon the attitudes and actions of the facility's planner, designer, constructor, and owner and the adequacy of maintenance funding. This Chapter of the **MAINTENANCE MANUAL** is intended to provide regulatory agencies with recommended methods for defining, securing, and coordinating the activities of these various concerns in order to achieve the highest possible degree of **SWMF** maintenance.

The specific objectives of this Chapter of the **MAINTENANCE MANUAL** are:

- * To emphasize the fundamental importance of **SWMF** maintenance to any successful municipal or county stormwater management program.
- * To identify the sources and causes of **SWMF** maintenance neglect.
- * To highlight the key role regulatory agencies can play in preventing and/or correcting such neglect and insuring adequate **SWMF** maintenance levels.
- * To recommend specific programs and procedures that will help regulatory agencies successfully assume this important role.

B. INTENDED READERS

This Chapter of the **MAINTENANCE MANUAL** is intended to provide information regarding regulatory programs and procedures to four categories of readers:

- * **Freeholders, Mayors, Council Members**, and other elected officials who have ultimate regulatory authority over municipal and county stormwater management and **SWMF** maintenance programs.
- * **Planning Boards, Boards of Adjustment**, and other municipal and county agencies who have direct regulatory authority over stormwater management and **SWMF** maintenance programs.
- * **Engineering, Planning, Public Works, and Road Department Officials** who implement stormwater management and **SWMF** maintenance policies and who provide technical advice to various municipal and county regulatory boards and agencies.

REGULATORY ASPECTS

* Land Developers, SWMF Owners, Consulting Engineers, and others who must receive regulatory approval from a municipal or county board or agency.

C. THE ROLE OF THE REGULATOR IN SWMF MAINTENANCE

As most municipal and county regulatory bodies are aware, the use of SWMFs to effectively address the adverse impacts of land development on stormwater runoff has grown rapidly in New Jersey. As the use of SWMFs has increased, so too has our experience and expertise in their planning, design, and construction. As a result, today's SWMFs play a vital role in our efforts to regulate land development and properly manage our stormwater resources.

However, to operate safely and effectively, SWMFs require thorough maintenance performed on a regular basis. As both the number of SWMFs and our reliance upon them grow, the importance of SWMF maintenance grows accordingly. However, experience has shown that, for a number of reasons, SWMF maintenance is often neglected or, at best, performed only sporadically. This maintenance deficiency poses a serious threat to the safe and effective operation of the SWMFs we have come to rely upon and to the health and safety of the very people the facilities are intended to protect. Information regarding the dangers of SWMF maintenance neglect can be found in Chapters Two, Three, and Four of this MANUAL. Additional information is presented in the NJDEP's Ocean County Demonstration Study Report.

As stated above, there are several reasons for maintenance neglect. Commonly, maintenance neglect occurs as a result of a lack of required maintenance personnel, equipment, and materials. This situation is usually related to a similar lack of sufficient maintenance funds. However, as discussed in various Chapters of this MANUAL, SWMF maintenance neglect may also be influenced by actions which occur prior to or during facility construction. These include inattentive or inadequate planning and design, incomplete project review, and poor construction methods and materials. Finally, neglected SWMF maintenance may be the result of irresponsible facility ownership, which may stem from an ignorance of, or disregard for, the importance of facility maintenance. Such owners may include municipal or county governments as well as private individuals, organizations, and corporations.

In order to prevent or overcome the problem of SWMF maintenance neglect, proper measures must be taken by all parties who are responsible for the conception, creation, and operation of a SWMF. In doing so, each party must be provided with proper guidance, assistance, and oversight.

REGULATORY ASPECTS

In addition, the activities of all the responsible parties must be closely coordinated to insure that, through their combined efforts, an effective and efficient level of SWMF maintenance can and will be provided. It is the responsibility of the regulator to provide this guidance, oversight, and coordination.

Fulfillment of this vital regulatory role must be accomplished on two levels:

* **Internal** programs and policies which oversee and coordinate the actions of all municipal or county departments, boards, and agencies relative to SWMF maintenance. This may involve such activities as the development of SWMF planning and design standards, the inspection of SWMF construction, and the performance and inspection of facility maintenance performed by municipal or county personnel.

* **External** programs and policies which promote SWMF maintenance through the regulation of the design, construction, maintenance, and ownership of SWMFs by private parties within a municipality or county. This may include such activities as the promulgation of SWMF planning and design standards, the review of land development proposals requiring the use of SWMFs, facility construction inspection, and the enforcement of ownership responsibilities.

The dual regulatory focus described above can be achieved through the development and implementation of four specific programs that reflect both internal and external activity on the part of a municipal or county government. They are:

1. SWMF REVIEW AND APPROVAL PROGRAMS
2. SWMF CONSTRUCTION INSPECTION PROGRAMS
3. SWMF MAINTENANCE INSPECTION PROGRAMS
4. PUBLIC ASSUMPTION OF SWMF MAINTENANCE

Information and recommendations regarding each of these regulatory programs are presented below. Prior to a discussion of each one, however, it is important to note a fundamental role for the regulator regarding SWMF maintenance.

The success or failure of any proposed program which must receive public support and approval is often determined by the degree of information the public receives. This is generally true of stormwater management programs, and particularly SWMF maintenance programs. In many instances, members of the general public have failed to appreciate the importance of SWMFs and their maintenance due to a lack of information and understanding regarding their purpose, operation, and effectiveness. When this lack of understanding is not adequately addressed, it may prevent a valuable and sound SWMF maintenance program from advancing beyond the proposal stage.

REGULATORY ASPECTS

Therefore, the value of a comprehensive public information and education program cannot be overemphasized. Such a program must explain the basis, purpose, and details of the proposal and must convince the public and their elected officials that it is both necessary to implement and beneficial to their interests. It must also explain the fundamentals of SWMFs, the vital role they play in our lives, and their need for regular maintenance. This information can be presented through flyers, brochures, posters, and other educational aids. Work sessions and field trips can also be conducted. Signs at facility sites illustrating the purpose and operation of a SWMF can also be erected. Finally, presentations to planning boards, municipal councils and committees, and county freeholders by stormwater management experts can also be of great assistance.

D. SWMF REVIEW AND APPROVAL PROGRAMS

As detailed in Chapter Two - Planning and Design Guidelines, the achievement of effective and efficient SWMF maintenance begins during the planning and design stages of a facility's development. It is during these stages that decisions are made which will affect the durability, accessibility, and maintainability of a SWMF after it has been constructed. It is also during this stage that the responsibilities and obligations of SWMF ownership are defined and assigned. This process is described in detail in Chapter One - Ownership and Maintenance Responsibility.

From the regulatory viewpoint, both of these important influences on SWMF maintenance are best addressed during the review and approval of a proposed project. Failure to do so at this early project stage will require expensive remedial action and/or additional maintenance efforts after the facility has been constructed and, most likely, the applicant is no longer available or accountable. To insure adequate consideration of both, the following recommendations regarding the development and implementation of a SWMF Review and Approval Program are offered:

1. Planning and design standards that eliminate, reduce, and/or facilitate SWMF maintenance should be adopted and promulgated. The use of such standards are particularly important if the proposed facility will ultimately be maintained by the municipality or county. The reader should refer to Chapter Two - Planning and Design Guidelines for detailed information regarding such standards.

The development of effective planning and design standards should also include coordination with other regulatory agencies which also have jurisdiction over SWMFs. This will require a cooperative and coordinated effort on the part of

REGULATORY ASPECTS

municipalities, counties, and applicable regional agencies such as the Pinelands Commission, CAFRA, the Delaware and Raritan Canal Commission, local Soil Conservation Districts, and the Hackensack Meadowlands Development Commission, as well as the N.J. Department of Environmental Protection. While this may appear to be a difficult task at best and complete interagency agreement may indeed not be plausible, it is an extremely worthy goal to strive for. As the degree of consistency between agency standards increases, the number of conflicting requirements decreases. This can only result in better, more comprehensive SWMF designs and less facility maintenance.

2. To insure that the adopted standards are being met, a comprehensive SWMF design review program should be established. This will include the development of a competent technical review staff. Training and continuing education programs are recommended in order to both attain and maintain the required level of staff competency and expertise. Provisions for hiring qualified consultants and SWMF experts on an as-needed basis should also be included.

3. Adequate funding for the design review program, including staff salaries and training and continuing education costs, must be provided. This can be achieved through a variety of methods, including the imposition of a SWMF design review fee payable by the applicant. Additional information regarding program financing is presented in **Chapter Six - Cost Data and Financing Techniques**.

4. To promote use of the adopted planning and design standards and expedite the SWMF review and approval process, the standards should be published in a readily understandable format and provided to all applicants free of charge or for a nominal fee. To prevent unauthorized changes or revisions, it is recommended that the objectives and goals of the standards be included in an ordinance or resolution duly adopted by the governing body of the municipality or county. However, to provide a useful degree of flexibility and to facilitate necessary and approved changes, the technical features of the standards should be contained in a handbook or other quasi-official document that does not require official governing body action to update and improve. In addition, communication between the applicant and review staff should be encouraged throughout the planning and design of the facility to help insure thorough understanding and application of the standards.

5. In addition to SWMF planning and design standards, the specific obligations and responsibilities of a SWMF owner should be adopted and promulgated. In addition, a procedure for formally identifying the owner of a SWMF should be developed. This procedure should be applicable throughout the life of the facility, not only during the facility review

REGULATORY ASPECTS

and approval stage. As described in Chapter One - Ownership and Maintenance Responsibility, it is essential that an entity or party with the ultimate responsibility for facility maintenance (i.e., the "Owner") be designated at all times throughout a SWMF's existence.

A procedure for addressing maintenance default by a negligent owner should also be developed and adopted. This default procedure should include provisions for appropriate owner notification and warning, performance of emergency maintenance, and recovery of expenses. To promote responsible SWMF ownership and deter maintenance neglect, the use of fines and other penalties against a negligent owner should be investigated.

A sample ordinance specifying the responsibilities of a SWMF owner and the procedure to be followed in case of maintenance neglect or default is presented in Table 5-1. This sample ordinance can be used by municipalities and counties as a guide for developing and adopting their own ordinance or resolution regarding these issues. Legal advice from the municipal attorney or county counsel should be obtained during the development process and prior to final adoption.

6. Periodic evaluation of the SWMF Review and Approval Program should be performed to help insure its continued effectiveness and efficiency. This evaluation process should include input from all departments and agencies associated with the various aspects of SWMF design, construction, and maintenance. Engineering and Planning Departments should be consulted regarding the current status of planning and design standards to insure that the latest ones are being applied to the planning, design, and review of the facility. Maintenance and inspection personnel should be consulted regarding the actual effectiveness of the standards in reducing or simplifying maintenance efforts. Additional input should be sought regarding any maintenance problems encountered in the field that are related to facility planning, design, review, or ownership. Appropriate revisions and improvements to specific aspects of the SWMF Review and Approval Program should be then be developed and implemented.

E. SWMF CONSTRUCTION INSPECTION PROGRAMS

By themselves, comprehensive SWMF designs and plans developed in accordance with approved standards cannot insure a reduction in SWMF maintenance. To achieve this goal, it is also necessary to insure that the actual SWMF has been constructed in accordance with the adopted standards using approved construction materials and techniques. It is the role of the regulator to develop and implement a comprehen-

REGULATORY ASPECTS

sive SWMF Construction Inspection Program to help achieve such results.

Similar to the SWMF review and approval stage, it is far more effective and efficient from a regulatory viewpoint to verify proper facility construction during the construction stage than to undertake costly remedial measures or incur additional maintenance expenses after construction has been completed. This is particularly important if the maintenance of the SWMF will eventually be assumed by the municipality or county. In addition, as discussed in **Chapter Three - Construction Inspection**, field changes are often required to correct design oversights or to accommodate unanticipated site conditions. A SWMF Construction Inspection Program can help identify and address these situations quickly and thoroughly. Recommendations regarding the development and implementation of such a program are presented below:

1. To insure that the SWMF is being constructed in accordance with the approved design, a comprehensive SWMF Construction Inspection Program should be established. This will include the development of a competent construction inspection staff. Training and continuing education programs are recommended in order to both attain and maintain the required level of staff competency and expertise. This training should include detailed descriptions of the purpose and function of SWMFs. Provisions for hiring qualified consultants and construction experts on an as-needed basis should also be included. The reader should refer to **Chapter Three - Construction Inspection** for details of recommended construction inspection practices.
2. Adequate funding for the Construction Inspection Program, including staff salaries, insurance premiums (see 3 below), and training and continuing education costs, must be provided. This can be achieved through a variety of methods, including the imposition of a SWMF construction inspection fee payable by the applicant. Additional information regarding program financing is presented in **Chapter Six - Cost Data and Financing Techniques**. Consideration should be given to the number of SWMFs that will be inspected under the program, both at the start of the program and after a period of years.
3. Prior to formal program adoption, legal advice should be sought regarding the liabilities inherent in a construction inspection program. These liabilities may include construction site safety and implied guarantees of facility performance and soundness. Advice should also be sought on the various legal aspects of the inspection program, including start and stop work orders, inspector authority, change orders, and extra work claims.

REGULATORY ASPECTS

4. Periodic evaluation of the SWMF Construction Inspection Program should be performed to help insure its continued effectiveness and efficiency. This evaluation process should include input from all departments and agencies associated with the various aspects of SWMF design, construction, and maintenance. Maintenance and inspection personnel should be consulted regarding the actual effectiveness of the construction inspection program. Engineering and Planning Departments should be consulted regarding the current status of planning and design standards and regulations which may affect the facility's construction. Additional input should be sought regarding any construction related problems encountered in the field that are related to facility planning, design, or review. This may include the adequacy of construction details and specifications included on the approved plans. Appropriate revisions and improvements to specific aspects of the SWMF Construction Inspection Program should be then be developed and implemented.

F. SWMF MAINTENANCE INSPECTION PROGRAMS

Once a SWMF has been designed and constructed, it must receive thorough maintenance at regular intervals in order to function properly and not pose a health or safety threat. This maintenance may be performed by one or more individuals or organizations from both the public and private sectors. To achieve this goal, it is also necessary to insure that facility maintenance is being performed in accordance with adopted standards using appropriate equipment and materials. It is the role of the regulator to develop and implement a comprehensive SWMF Maintenance Inspection Program to insure that required levels of facility maintenance are being performed and that maintenance deficiencies and problems are promptly identified, reported, and rectified.

In providing for adequate SWMF maintenance, it is far more effective and efficient to perform preventative maintenance tasks on a regular basis than to undertake major remedial or corrective actions on an as-needed basis in response to a serious maintenance condition. This is particularly important if the maintenance of the SWMF will eventually be assumed by the municipality or county. In addition, as discussed in **Chapter Four - Maintenance Equipment and Procedures**, the presence of an attractive, well maintained SWMF can add to the quality of the lives of the people who live and work near the facility as well as boost the morale of maintenance personnel and promote a higher standard of maintenance excellence. Recommendations regarding the development and implementation of a comprehensive inspection program that will help insure that such maintenance is being performed are presented below:

REGULATORY ASPECTS

1. To insure that both public and private SWMF maintenance is being conducted in accordance with facility requirements and adopted standards, a comprehensive SWMF Maintenance Inspection Program should be established. This will include the development of a competent maintenance inspection staff. Training and continuing education programs are recommended in order to both attain and maintain the required level of staff competency and expertise. This training should include detailed descriptions of the purpose and function of SWMFs and the fundamental importance of proper facility maintenance. Provisions for hiring qualified consultants and construction experts on an as-needed basis should also be included. To maximize available personnel, consideration should be given to consolidating the inspection duties of both the construction and maintenance inspection staffs. The reader should refer to appropriate sections of **Chapter Four - Maintenance Equipment and Procedures** for details of recommended maintenance inspection practices.

2. Adequate funding for the Maintenance Inspection Program, including staff salaries, insurance premiums (see No. 3 below), and training and continuing education costs, must be provided. This can be achieved through a variety of methods, including the imposition of a SWMF maintenance inspection fee payable by the applicant. Additional information regarding program financing is presented in **Chapter Six - Cost Data and Financing Techniques**. Consideration should be given to the number of SWMFs to be inspected under the program, both at the start of the program and after a period of years.

3. Prior to formal program adoption, legal advice should be sought regarding the liabilities inherent in a maintenance inspection program. These liabilities may include inspector safety, implied guarantees of facility performance and soundness, and latent liability for any design or construction related problems encountered during maintenance inspections. Advice should also be sought on the various legal aspects of the inspection program, including owner notification of maintenance neglect, inspector authority, emergency maintenance required to correct serious maintenance conditions, recovery of emergency maintenance costs, and owner penalties and fines.

4. Periodic evaluation of the SWMF Maintenance Inspection Program should be performed to help insure its continued effectiveness and efficiency. This evaluation process should include input from all departments and agencies associated with the various aspects of SWMF design, construction, and maintenance. Maintenance and inspection personnel should be consulted regarding the actual effectiveness of the maintenance inspection program. Engineering and Planning Departments should be consulted regarding the current status of planning and design standards and regulations which may

REGULATORY ASPECTS

affect the facility's maintenance. Additional input should be sought regarding any maintenance related problems encountered in the field that are related to facility planning, design, review, or construction. Appropriate revisions and improvements to specific aspects of the SWMF Construction Inspection Program should then be developed and implemented.

G. PUBLIC ASSUMPTION OF SWMF MAINTENANCE

There are several instances where a municipality or county may assume the maintenance of a privately owned and/or constructed SWMF. Foremost among them are two primary reasons:

* As a reactive measure to chronic neglect of a SWMF by its private owner. Such action is normally taken after all other regulatory and legal measures to address the maintenance default have been exhausted and, as such, represents the last option available to a municipality or county seeking to insure adequate maintenance of the SWMFs within its borders.

* As a proactive measure prior to the construction of a SWMF. Such action may be taken to avoid an anticipated maintenance default or problem by a potentially negligent owner. Criteria for evaluating this possibility is presented in Chapter One - Ownership and Maintenance Responsibility. In other instances, inclusion of the private facility into an established municipal or county SWMF maintenance program may prove to be more effective and efficient than private maintenance efforts.

Regardless of the basis for the action, there are many ramifications of public assumption of SWMF maintenance that must be considered prior to official municipal or county action. Therefore, a comprehensive analysis of these ramifications, including the reasons for and consequences of the maintenance assumption, should be conducted. This analysis should include:

1. A comprehensive review of the legal liabilities of maintenance assumption. This review should include the municipal attorney or county counsel and should address such aspects as injury to maintenance personnel, third party injuries, liability for facility operation and soundness, and latent liability for pre-existing hazardous or dangerous conditions which are discovered after maintenance has been assumed.

2. A comprehensive review of the legal aspects of the maintenance assumption. This review should include the municipal attorney or county counsel and should address such issues as the consent and cooperation of the facility owner,

REGULATORY ASPECTS

access easements, and division of ownership responsibilities. As discussed in **Chapter One - Ownership and Maintenance Responsibility**, the municipality or county may wish to acquire ownership of the facility or simply to retain access rights. Additional information regarding these issues is presented in Chapter One.

3. A comprehensive review of required insurance coverage and affiliated costs based upon the results of the legal reviews described above.

4. A comprehensive review of the labor, equipment, and materials required to satisfactorily assume and provide the necessary level and frequency of facility maintenance. This review should include direct consultation with the department or agency responsible for performing the facility maintenance. The information regarding specific SWMF maintenance tasks presented in **Chapter Four - Maintenance Equipment and Procedures** can be used as a guide in these discussions. In general, public assumption of facility maintenance will be easier if the municipal or county already performs SWMF or related maintenance services.

5. A comprehensive review of both the costs and financing of the maintenance assumption. This review should include the appropriate municipal or county financial personnel, including the business administrator, comptroller, and/or financial director. Both maintenance cost data and financing measures are presented in **Chapter Six - Cost Data and Financing Techniques**.

In addition to the above, the following recommendations are offered for maintenance assumption at existing and proposed SWMFs:

* If maintenance is to be assumed at an existing SWMF, the entire history of the facility should be examined with all municipal and county personnel involved in its review, approval, construction, and inspection. This should include a review of all available records of such activities and actions. If the reason for the maintenance assumption is due to owner neglect and default, the cause of this default, any recorded owner notifications, hearings, or warnings, and the present condition of the facility should also be reviewed. The review of the facility's condition should include an assessment of any inherent maintenance problems and possible structural solutions by the municipal or county technical and maintenance staffs. Such structural solutions can reduce the amount of maintenance that must be performed at the facility and may even allow the facility's owner to eventually resume maintenance responsibility. Finally, potential methods of recovering maintenance costs from the owner should be investigated. These may include the assessment of fines, maintenance fees, or other charges.

REGULATORY ASPECTS

* If maintenance is to be assumed at a **proposed SWMF**, the basis for such action should be clearly identified and documented. The decision to assume the maintenance of a proposed SWMF may be based upon several factors, including the type of land development associated with the facility (e.g., residential, commercial, industrial, etc.), the type of facility owner (e.g., residential lot owner, homeowners or condominium association, private corporation, etc.), and past experience with SWMF maintenance problems and defaults. Criteria for evaluating the potential for maintenance problems at SWMFs operated by various types of SWMF owners is presented in **Chapter One - Ownership and Maintenance Responsibility**.

Identification of the basis for the maintenance assumption will establish a rationale for such action, which can then be used to equitably evaluate future projects and facilities as well. It will also help to justify the actions of the municipality or county in assuming the facility's maintenance and the associated expenses and commitment of public personnel, equipment, and materials. Finally, a method of financing the maintenance effort should be developed and implemented. Recommended financing programs for SWMF maintenance are presented in **Chapter Six - Cost Data and Financing Techniques**. Methods which require contributions by the owner of the facility which is to be publicly maintained are the most equitable and justifiable.

REGULATORY ASPECTS

TABLE 5-1

N. J. DEPARTMENT OF ENVIRONMENTAL PROTECTION
STORMWATER MANAGEMENT FACILITIES MAINTENANCE MANUAL

SAMPLE SWMF MAINTENANCE ORDINANCE

This Table presents sample language which may be used by a municipality or county to establish an ordinance or resolution regarding private SWMF maintenance responsibility, performance, and default. Final development and adoption of such an ordinance or resolution should include the review and approval of the municipal attorney or county counsel. See text for further information.

A. RESPONSIBLE PERSON OR ENTITY

Responsibility for the operation and maintenance of stormwater management facilities, including grass mowing and periodic removal and disposal of accumulated particulate material or debris, shall remain with the owner or owners of the property, with permanent arrangements that it shall pass to any successive owner unless assumed in part or in full by a government agency. If portions of the land are to be sold, legally binding arrangements shall be made to pass the maintenance responsibility to successors in title. These arrangements shall designate for each facility the property owner, governmental agency, or other legally established entity to be permanently responsible for maintenance, herein after in this Section referred to as the responsible person or entity.

B. MAINTENANCE AGREEMENT

Prior to granting approval to any project subject to review under this ordinance, the applicant shall enter into an agreement with the (Municipality or County) to ensure the continued operation and maintenance of the stormwater management facility. This agreement shall be in a form satisfactory to the (Municipal Attorney or County Counsel), and may include, but may not necessarily be limited to, personal guarantees, deed restrictions, covenants, and bonds. In cases where property is subdivided and sold separately, a Homeowner's Association or similar permanent entity should be established as the responsible entity, in the absence of an agreement by a governmental agency to assume full maintenance responsibility.

REGULATORY ASPECTS

TABLE 5-1 (CONTINUED)

C. FACILITY INSPECTION

At those stormwater management facilities where a responsible person or entity other than the (Municipality or County) retains part or full responsibility for the maintenance of the facility, the agreement cited in Paragraph B above shall contain a provision granting authorized personnel of the (Municipality or County) the right to enter the property upon which the facility is located for the purpose of inspecting the facility. Such inspections shall be made in such a manner and at such times as not to interfere with the owner's use of the property. The agreement cited in Paragraph B above shall also contain a provision granting the (Municipality or County) a permanent easement which completely encompasses the facility and connects to a public road or right-of-way.

D. MAINTENANCE DEFAULT

In the event that the responsible person or entity fails to properly maintain the stormwater management facility and/or the facility becomes a danger to public health or safety, the (Municipality or County) may serve written notice upon the responsible person or entity stating: (1) The condition(s), defect(s), or problem(s) which require(s) elimination or correction, (2) a reasonable time period in which to perform the necessary maintenance and repairs, and (3) consequences and actions to be taken by (Municipality or County) for failure to perform necessary maintenance and repairs within the specified time frame. In the event that the responsible person or entity fails to correct or eliminate the specified condition, defect, or problem within the designated time, the (Municipality or County) may enter the property upon which the facility is located and cause the necessary maintenance and repairs to be done at the expense of the responsible person or entity.

E. EMERGENCY REPAIRS

In the event that an emergency situation arises which makes it impractical to serve written notice and provide a reasonable period for completion of necessary maintenance and repairs, then, and in that event, the (Municipality or County) may enter the property upon which the facility is located immediately and perform or cause to be performed such maintenance and repairs that it, in its sole judgment, deems necessary. Such maintenance and repairs shall be done at the expense of the responsible person or entity.

**NEW JERSEY
DEPARTMENT OF ENVIRONMENTAL PROTECTION
STORMWATER MANAGEMENT FACILITIES
MAINTENANCE MANUAL**

**CHAPTER SIX
COST DATA AND FINANCING TECHNIQUES**

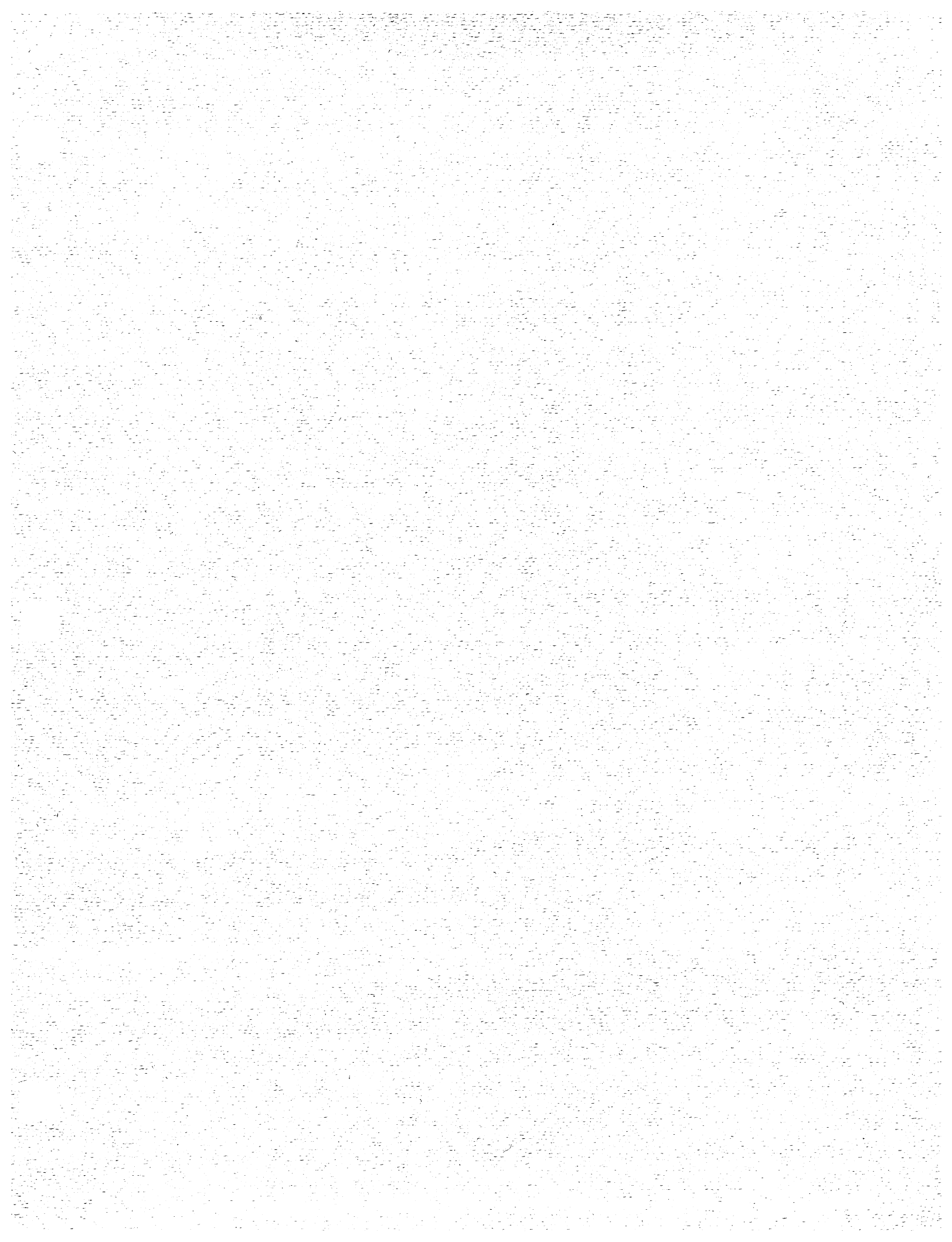

N.J. DEPARTMENT OF ENVIRONMENTAL PROTECTION
STORMWATER MANAGEMENT FACILITIES MAINTENANCE MANUAL

CHAPTER SIX - COST DATA AND FINANCING TECHNIQUES

TABLE OF CONTENTS

A. OBJECTIVES	COST-1
B. INTENDED READERS	COST-1
C. OVERVIEW OF SWMF MAINTENANCE FINANCING	COST-2
D. SWMF MAINTENANCE COSTS	COST-3
E. PUBLIC FINANCING OF SWMF MAINTENANCE	COST-5
1. GENERAL TAX REVENUES	COST-8
2. UTILITY CHARGES	COST-9
3. PERMIT FEES	COST-11
4. DEDICATED CONTRIBUTIONS	COST-13
F. SWMF MAINTENANCE COST SAVINGS	COST-15

TABLE 6-1 SWMF MAINTENANCE EQUIPMENT AND MATERIAL COSTS	COST-17
TABLE 6-2 COSTS OF SWMF MAINTENANCE TASKS	COST-20
TABLE 6-3 SAMPLE WORKSHEET FOR CALCULATING DEDICATED CONTRIBUTION TO SWMF MAINTENANCE	COST-22
TABLE 6-4 COST DATA AND FINANCING TECHNIQUES - SELECTED REFERENCES	COST-26

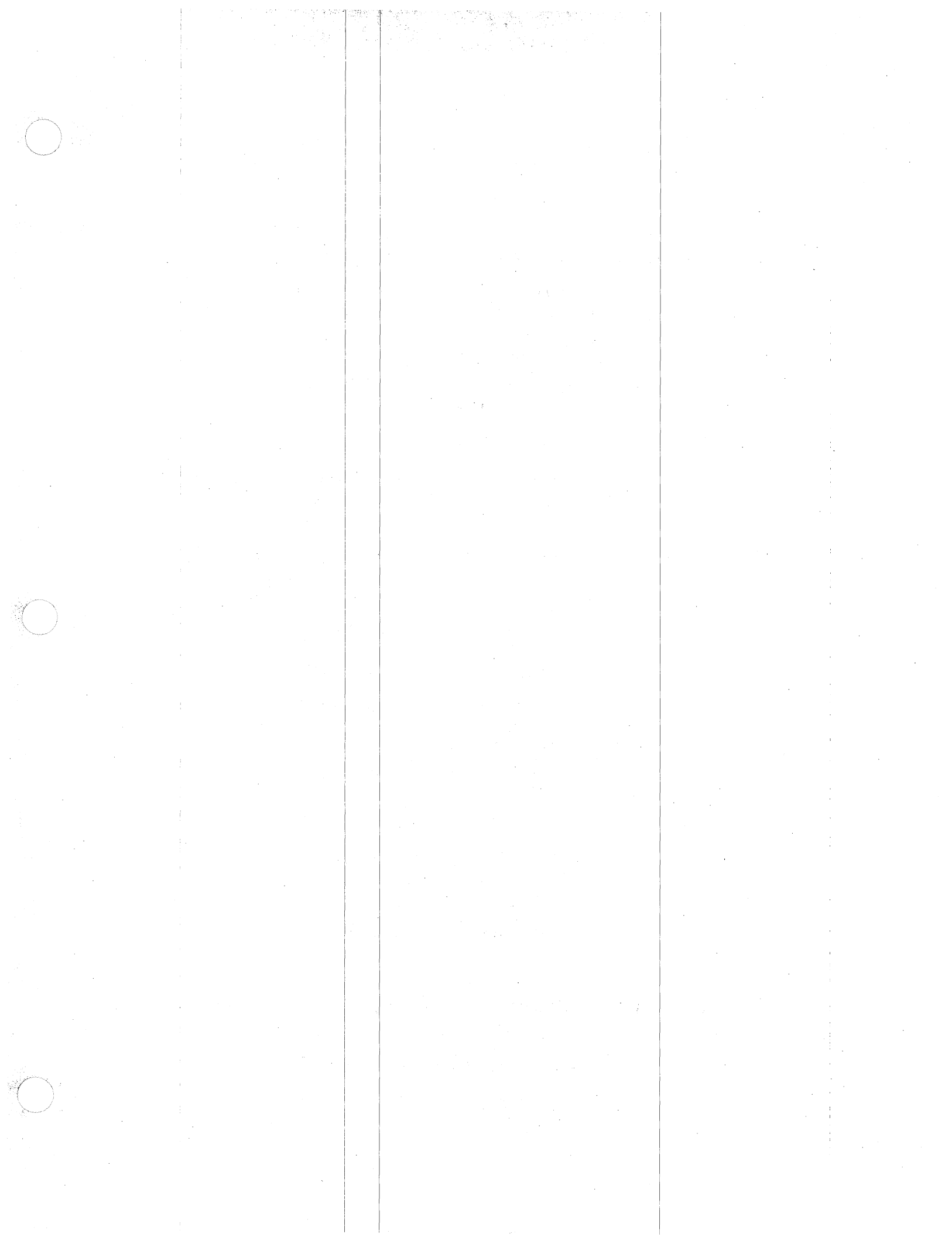

COST DATA AND FINANCING TECHNIQUES

A. OBJECTIVES

This Chapter of the **STORMWATER MANAGEMENT FACILITIES MAINTENANCE MANUAL** discusses what may be the most important aspect of Stormwater Management Facility (or SWMF) maintenance: **How to Finance It**. The fundamental role that proper financing plays in the successful performance of effective SWMF maintenance cannot be overemphasized. Because of its importance and the complexities inherent in any financing effort, the provision of adequate maintenance funding will require greater, more sophisticated, and more creative efforts on the part of public and private agencies than any other aspect of stormwater management.

The specific objectives of this Chapter of the **MAINTENANCE MANUAL** are:

- * To emphasize the fundamental role financing plays in the performance of effective SWMF maintenance.
- * To provide capital and operating expense data to those responsible for preparing SWMF maintenance budgets and obtaining SWMF maintenance funds.
- * To provide information to both municipal and county governments regarding various alternative methods of publicly financing required SWMF maintenance.
- * To provide advice on reducing overall SWMF maintenance costs through specific planning, design, construction, and maintenance practices.

B. INTENDED READERS

This Chapter of the **MAINTENANCE MANUAL** is intended to provide a comprehensive SWMF maintenance cost database to:

- * Stormwater Management Facility Owners.
- * Directors of Maintenance, Public Works, and Road Departments and other public and private agencies responsible for SWMF Maintenance.
- * Purchasing Agents, Managers, and Directors.

It is also intended to illustrate various methods of obtaining adequate public funds for required SWMF maintenance to:

- * Mayors, Council Members, Freeholders, Board Members, and other leaders of municipal and county governments responsible for SWMF maintenance.

COST DATA AND FINANCING TECHNIQUES

* **Business Administrators, Comptrollers, Financial Directors, and other municipal and county officials responsible for publicly financing SWMF maintenance.**

In addition, this Chapter can provide valuable financial information and insight regarding SWMF maintenance to:

- * **SWMF Planners, Designers, and Reviewers.**
- * **Engineering and Planning Department Personnel.**
- * **SWMF Maintenance Personnel.**

Finally, specific measures for reducing overall SWMF maintenance costs are presented for readers actively involved in private or public stormwater management programs.

C. OVERVIEW OF SWMF MAINTENANCE FINANCING

As discussed in previous chapters of this **MANUAL**, the use of SWMFs to effectively address the adverse impacts of land development on stormwater runoff has grown rapidly in New Jersey. As the use of SWMFs has increased, so too has the experience and expertise in their planning, design, construction, and regulation. As a result, today's SWMFs play a vital role in the effort to properly manage stormwater resources.

However, to operate safely and effectively, SWMFs require thorough maintenance performed on a regular basis. As both the number of SWMFs and the reliance upon them grows, the importance of SWMF maintenance grows accordingly. However, experience has shown that, for a number of reasons, SWMF maintenance is often neglected or, at best, performed only sporadically. This maintenance deficiency poses a serious threat to the safe and effective operation of the SWMFs we have come to rely upon and to the health and safety of the very people the facilities are intended to protect. Information regarding the dangers of SWMF maintenance neglect can be found in Chapters Two, Three, and Four of the **MAINTENANCE MANUAL**. Additional information is presented in the **NJDEP's Ocean County Demonstration Study Report**.

As stated above, there are several reasons for this maintenance neglect. However, research conducted during the development of the **MAINTENANCE MANUAL** indicates that a primary cause is a **lack of adequate maintenance funds**. The problem of inadequate funding manifests itself in several ways, including insufficient manpower, inadequate equipment, inattentive facility inspections, and ineffective maintenance efforts. However the problem occurs, the result is the same: **SWMF maintenance neglect**.

COST DATA AND FINANCING TECHNIQUES

Similarly, the problem of inadequate SWMF maintenance funding also has several causes, including legal and regulatory constraints, a shortage of overall operating funds, and poor stormwater management program planning. These causes signify an overall failure to recognize SWMF maintenance as a key component of any stormwater management program. One remedy can be achieved through a comprehensive information and education program, including the distribution and use of this Manual by both the public and private sectors. Further solutions will require both commitment and creativity on the part of those in both sectors responsible for providing the necessary SWMF maintenance funds, as well as a sound financial database upon which to base their maintenance financing decisions. As detailed below, this Chapter of the **MAINTENANCE MANUAL** will offer information, advice, and recommendations in both of these key areas.

D. SWMF MAINTENANCE COSTS

In order to develop sound SWMF maintenance budgets and determine adequate funding levels, a comprehensive database of SWMF maintenance costs is essential. Presented in Tables 6-1 and 6-2 are cost estimates of various equipment, materials, and tasks typically associated with SWMF maintenance. These estimates are based upon data received from many sources, including maintenance departments and companies; equipment manufacturers, wholesalers, and retailers; and various municipal and county government agencies and departments. The data was obtained through several methods, including interviews, surveys, questionnaires, and a search of reference and research literature.

The cost estimates presented in the Tables below are intended to provide generalized cost data to those in both the public and private sectors of New Jersey involved in the financial planning of SWMF maintenance. In light of such a broad user base and wide spectrum of applications, the development of more detailed cost estimates is beyond the scope of this Chapter. Therefore, where required, the reader may wish to develop more detailed cost estimates based upon data pertaining to a specific program or facility. The values presented in the Tables below will provide an excellent foundation for such efforts.

Sources of more specific cost data include local equipment sales, lease, and/or rental agencies, and local maintenance and construction contractors. Valuable information can also be obtained from the Municipal Public Works or County Road or Park Departments, as well as the Municipal or County Engineer's Office. To help insure both the accuracy and acceptability of detailed cost estimates to be prepared by public officials, consultation and coordination between the

COST DATA AND FINANCING TECHNIQUES

various departments, agencies, and boards within the municipal or county government are strongly recommended. Close interaction between the various departments of private companies and agencies is similarly encouraged.

The reader should note that, due to varying labor and overhead rates throughout New Jersey's public and private sectors, the cost data for the SWMF maintenance tasks presented in Table 6-2 is expressed in terms of estimated man-hours. These values should be used in conjunction with applicable personnel rates to determine labor costs for a specific program or facility.

In addition, the cost estimates for the SWMF maintenance tasks presented in Table 6-2 are also expressed for two SWMF sizes. These facility sizes are defined below:

Small Facility: Total SWMF Site Area = 1/4 Acre
Large Facility: Total SWMF Site Area = 1 Acre

The reader should note that the areas presented in the above definitions pertain to the entire facility site area, which is assumed to include both the facility's impoundment area and a perimeter buffer. In addition, each size facility is assumed to be entirely covered with grass which requires regular mowing, fertilizing, and other maintenance. These assumed facility sizes and characteristics have been selected as typical of the onsite SWMFs normally encountered in developed portions of New Jersey. Appropriate adjustments to the cost estimates presented in Table 6-2 should be made as necessary to account for actual facility size. Additional adjustments should be made for regional and other SWMFs that utilize existing ground cover which does not require mowing.

The reader should note the effective date of each cost estimate table, which represents the calendar year in which the cost estimates were compiled. Appropriate revisions to the estimates should be made where necessary to account for such factors as inflation, availability of materials and equipment, and technological advances which may have occurred since the effective date of the estimates. Such adjustments may be based upon the consumer price index or other cost indices, inflation estimates, and other appropriate indicators.

The reader should also note that, in addition to the equipment, material, and labor cost estimates presented in Tables 6-1 and 6-2, an additional allowance for the disposal of such items as trash, debris, leaves, and sediment should be included in any SWMF maintenance cost estimate. Disposal of such items must comply with all municipal, county, state, and federal waste flow regulations, including the use of suitable disposal sites, and therefore may vary widely

COST DATA AND FINANCING TECHNIQUES

throughout the state. The Division of Solid Waste Management of the New Jersey Department of Environmental Protection and municipal and county solid waste agencies should be contacted for appropriate disposal cost information.

Finally, the items presented in the cost estimate tables can be readily cross referenced with the SWMF maintenance tasks, equipment, and materials presented in **Chapter Four - Maintenance Equipment and Procedures**. More detailed information regarding SWMF maintenance tasks, equipment, and materials may also be found in this Chapter.

E. PUBLIC FINANCING OF SWMF MAINTENANCE

As discussed above, a primary cause of SWMF maintenance neglect is a lack of adequate funds. This conclusion, which is supported by interviews, surveys, questionnaires, and other research conducted during the development of the **MAINTENANCE MANUAL**, is particularly troublesome to municipal and county governments who either have assumed or wish to assume the responsibility for such maintenance. Assumption of SWMF maintenance may take the form of direct involvement by municipal or county maintenance personnel or by contracting with private maintenance services.

In the case of municipalities or counties which have already assumed such maintenance, the lack of adequate funding has led to a seriously high level of facility maintenance default. This not only creates severe health and safety hazards for their residents, but may also threaten the continuation of their overall stormwater management program. It is extremely difficult to generate the vital local support that a successful stormwater management program requires if the local residents are surrounded by SWMFs produced by that program that are unsightly, unsafe, and ineffective.

In addition, a municipality or county may wish to assume the maintenance of some or all of the privately constructed SWMFs within its borders. This assumption of facility maintenance may be based upon the desire to avert an anticipated default by a potentially negligent owner. It may also reflect a last resort effort by the municipality or county to restore and maintain an existing facility which has already suffered continued neglect by its owner. In either case, a lack of adequate funds will prevent the municipality or county from assuming this maintenance, which in turn will only add to the growing list of unsightly, unsafe, and ineffective SWMFs within its borders.

The problem of inadequate SWMF maintenance funding described above indicates that the traditional measures of public financing in the State may either be ill-suited for this

COST DATA AND FINANCING TECHNIQUES

purpose or are not being utilized to their fullest extent. In response to these factors, four SWMF maintenance funding sources or programs have been identified which, individually or in combination, may serve as an adequate source of funds to meet a municipality's or county's SWMF maintenance obligations or desires. These four recommended funding sources, which represent a combination of traditional and innovative measures, are:

1. General Tax Revenues
2. Utility Charges
3. Permit Fees
4. Dedicated Contributions

Details of these four sources or programs are presented below, along with suggested criteria for evaluating the suitability of each to a particular municipality or county. Prior to a discussion of each one, however, it is important to note some fundamental aspects of public SWMF maintenance financing.

The success or failure of any proposed financing program which must receive public support and approval is often determined by the degree of information the public receives. For a number of reasons, the public is generally protective of its dollars and initially suspicious of any new public program which proposes to spend them. In most instances, this suspicion is beneficial, for it helps promote sound fiscal planning and spending programs.

However, where this suspicion is unwarranted and cannot be overcome, it may also prevent a valuable and fiscally sound program from advancing beyond the proposal stage. Therefore, the value of a comprehensive public information program cannot be overemphasized. Such a program must explain the basis, purpose, and details of the financing proposal and must convince the public and their elected officials that it is both necessary to implement and beneficial to their interests. Additional information regarding the need for, and details of, such a program is presented in Chapter Five - Regulatory Aspects.

Secondly, all successful SWMF maintenance funding programs should possess certain fundamental elements or characteristics. Each should:

* Be based upon a stable source of consistent funds. Proper SWMF maintenance must be continually and consistently performed on a regularly scheduled basis and, therefore, requires a long term commitment of personnel, equipment, and materials. As a result, the funds to support this commitment must be based upon a stable, secure, and reliable source.

COST DATA AND FINANCING TECHNIQUES

* Be compatible with the local organizational structure in which it will operate. The overall effectiveness of a SWMF maintenance program is based to a large extent upon the efficiency of its funding program. The most efficient SWMF maintenance funding program is that which is most compatible with the organizational structure of the managing department, agency, or authority. Wherever possible, the funding program should utilize the billing, collection, and book-keeping operations of an existing public system such as a Utilities Authority or Water Department.

* Include provisions for the following operations:

1. Program Administration
2. Accounting and Budgeting
3. Revenue Management
4. Information Management

Program Administration is necessary to insure the effective and efficient operation of the overall program. Accounting and Budgeting procedures are necessary to accurately track operations and determine required funding levels. This may include the use of detailed work orders and time sheets by maintenance and inspection personnel and their supervisors. Revenue Management must insure a secure and reliable source of program funds to meet expenses and oversee their expenditure. Information Management must provide all of the above with comprehensive and accurate data upon which operational decisions can be based. It must also foster program understanding and support by providing government leaders and members of the public with timely information, explanations, and answers. As described above, the program should utilize the operational framework of an existing authority, department, or agency in order to maximize efficiency and minimize overall costs.

* Be based upon a equitable, understandable, and defensible fee or rate structure. SWMF maintenance funding programs may require complex procedures and operations in order to provide adequate funding levels. However, in order to achieve public acceptance and support, the program's fees or rates must be based upon a formula or method that can be readily explained to and understood by that public. The fees or rates must be perceived as being both reasonable and equitable and based upon accurate data and sound decisions.

* Be continually reviewed and updated to adjust to changes in program costs, revenues, and responsibilities. To do so, the program must possess a flexibility of approach which will allow it to quickly respond to such changes.

Finally, it is important to note that all municipal and county financing measures in New Jersey are governed to some degree by the same State laws and regulations and all are

COST DATA AND FINANCING TECHNIQUES

subject to oversight by various State Boards and Departments. However, the final details of a specific public SWMF maintenance financing program will depend to a great extent upon the general accounting practices and financial rules and policies of the municipality or county which implements it. It is beyond the scope of this Chapter to address in detail all of the prevailing factors which must be addressed in establishing such a program. Therefore, the information presented below is intended as a general planning guide to public officials interested in establishing a SWMF maintenance financing program within their municipality or county. Prior to the actual adoption of such a program, it should receive the review and approval of the county counsel, municipal attorney, and/or registered municipal accountant as well as the appropriate certifications from the New Jersey Division of Local Government Services and/or the Local Finance Board. The program characteristics presented above can be used as general criteria in selecting the most appropriate SWMF maintenance funding program or programs.

The reader should also note that, in addition to the specific information regarding each of the financing programs presented below, a list of references is presented in Table 6-4. Each of these references, which have been used in the development of this Chapter, contains additional information regarding one or more of the recommended programs.

1. GENERAL TAX REVENUES

General tax revenues are an obvious source of funding for a municipality's or county's SWMF maintenance efforts, particularly for existing facilities. The purpose of municipal and county taxes is to obtain the funding necessary to provide for the community's health, safety, and welfare through a number of social, economic, recreational, and environmental programs. Therefore, in light of the public health and safety benefits provided by a properly functioning SWMF and the serious health and safety hazards created by its neglect, the use of general tax revenues to provide for the maintenance of the facility can be construed as being consistent with this purpose.

However obvious, general tax revenues may also be the least suitable source of SWMF maintenance funding. As the name implies, "general" tax revenues originate at a number of sources and are used to finance an equally diverse number of public programs, including police and fire protection, civil and criminal courts, social and economic support programs, roadways, utilities, and other infrastructure components, and recreational activities and facilities. This combination of broad base and use creates two distinct problems which must be overcome if general tax revenues are to be utilized to support public maintenance of SWMFs.

COST DATA AND FINANCING TECHNIQUES

First, with such a broad base, it may be difficult to justify the expenditure of general tax revenues to maintain a SWMF that will only benefit a portion of the taxpaying community. Second, with an equally broad use, SWMF maintenance must compete against a large number of other vital public programs for a limited amount of tax dollars. This latter problem is compounded by the presence of the State "CAP" law (Public Law 1976, Chapter 68) which limits the annual growth of municipal and county expenditures.

Elected officials have discretionary authority in allocating general tax revenues through the annual budget process. However, both a government's responsibilities and its political realities tend to define how these funds are actually spent. Mandatory services such as police and fire protection must receive priority over more discretionary budget items such as SWMF maintenance. Therefore, in order to utilize general tax revenues as a source of SWMF maintenance funding, it must be satisfactorily demonstrated that this activity has greater importance than other discretionary budget items.

The success of this effort will depend upon many factors, including the overall costs and community benefits of the maintenance program, the severity and extent of the maintenance neglect problem, and, as described above, the effectiveness of the methods utilized to inform and educate the public and their elected officials. In estimating overall program costs, the cost of providing the recommended administrative and support operations itemized on Page 7 should be included. Based upon available data, such expenses are estimated to range from approximately 10 to 20 percent of total program costs. Allowances for the cost of necessary program liability insurance should also be included.

2. UTILITY CHARGES

The use of utility charges to publicly finance SWMF maintenance represents a relatively new application of an established component of municipal and county revenues. The use of such charges to finance publicly owned water and sanitary sewerage systems in New Jersey began in the early 1900's and, today, provides a stable source of funds for municipal and county utility authorities and agencies throughout the state. Since the adoption of the State "CAP" law cited above, utility charges have become increasingly popular as both municipalities and counties attempt to maintain an adequate level of public services in the face of State mandated limits on expenditure growth.

COST DATA AND FINANCING TECHNIQUES

The concept of a utility charge to publicly finance SWMF maintenance is a sound one in several respects. Unlike general tax revenues, utility charges are not subject to State "CAP" law limitations. In addition to the precedent set by water and sewer charges, the activities and types of costs required to effectively maintain SWMFs within a certain utility "district" are similar in nature to those required for other utilities. As described above, an existing municipal or county utility authority provides an excellent organizational framework in which to implement the SWMF maintenance charge concept. A more direct relationship between the costs and benefits of a SWMF maintenance program can be demonstrated through the establishment of an appropriately selected and delineated SWMF maintenance district than through the general assessment of municipal or countywide taxes. Finally, similar to general tax revenues, the utility charge can be used to publicly finance the maintenance of both new and established SWMFs.

It is important to note that the use of utility charges to publicly finance SWMF maintenance differs in some respects from water and sewerage utilities. Unlike charges for water supply, a readily measurable commodity is not delivered to the SWMF maintenance district member or customer. To a lesser extent, the service provided by SWMF maintenance is not as readily perceived or quantified as the service provided by a sewerage system which continually disposes of sanitary wastes from residences and businesses. As a result, the services provided to and the benefits received by the utility customer must be more broadly defined if an acceptable and equitable utility charge or rate structure is to be developed.

The utility rate structure for a SWMF maintenance district should be based upon several considerations. The most fundamental of these is the concept of payment based upon contribution to the need for the maintenance rather than the benefits provided by it. For example, a typical SWMF maintenance charge may be based upon the size of the property contributing runoff to the facility. This rate may be refined to reflect the percentage of impervious surfaces on the property, the stormwater runoff potential of the remaining pervious areas (e.g., as determined by the soil's SCS Hydrologic Soil Group), the type of land use on the property, and other factors affecting either the rate or volume of stormwater runoff. Therefore, for example, a one acre property containing a single family residence with 20 percent of its total area covered with impervious surfaces would pay proportionally less for the maintenance of the SWMF to which it contributes runoff than a similarly sized industrial property with 80 percent impervious cover.

COST DATA AND FINANCING TECHNIQUES

While a certain degree of complexity may be required to equitably distribute maintenance costs throughout the district, the rate structure should also remain as simple as possible. As described above, this simplicity will help make the rate structure more understandable to the rate payer and, as a result, more acceptable as well. The rate structure should also retain a degree of flexibility in order to accommodate changes in program revenues, expenses, and responsibilities.

Finally, the rate structure should reflect the costs of providing the recommended SWMF maintenance funding program operations itemized on Page 7. Based upon available data, such administrative and support costs are estimated to range from approximately 10 to 20 percent of total program costs. Allowances for the cost of necessary program liability insurance should also be included.

Similar to the utility rate structure, the limits of the SWMF maintenance district should be based upon the contribution of runoff to the SWMF (and therefore the need for its maintenance) rather than the benefits provided by the maintenance. This may include the tributary drainage area for a single SWMF or an entire network of facilities. In establishing the district limits, consideration must also be given to establishing an accurate relationship between program benefits and costs. As the size of the district increases and additional facilities are included within it, the accuracy and validity of this relationship decreases. Conversely, the establishment of several relatively small districts may unnecessarily increase overall program administration and support costs.

Finally, as described on Page 8, any SWMF maintenance funding program based upon utility charges should receive the review and approval of legal counsel and the certification of all appropriate State boards and agencies.

3. PERMIT FEES

Similar to utility charges, the use of permit fees to publicly finance SWMF maintenance represents a relatively new application of an established component of municipal and county revenues. In New Jersey, municipalities and counties have the general authority to establish fees and other charges to pay for the operational expenses (including maintenance) of various programs and services. Often, these fees are associated with the issuance of a permit, such as a building permit, soil removal permit, or sewer connection permit. Since the adoption of the State "CAP" law cited above, such fees, which are not subject to "CAP" limitations, have become increasingly popular as both municipalities and counties attempt to maintain an adequate

COST DATA AND FINANCING TECHNIQUES

level of public services in the face of State mandated limits on expenditure growth.

The successful implementation of a SWMF maintenance funding program based either entirely or in part upon the collection of permit fees requires the establishment of two primary relationships. First, the permit program itself must be directly related in some manner to SWMFs and, preferably, their maintenance. For example, the use of fees from a sanitary sewer connection permit program to finance stormwater management facility maintenance may not be feasible or permissible. However, the use of fees from a storm sewer connection permit program may be. Other potentially feasible permit fees include those for a municipal or county SWMF construction permit or stormwater discharge permit. Obviously, a permit program based upon annual fee charges for ongoing activities such as a stormwater discharge permit can provide a continuing source of funds.

Second, a relationship should be established if possible between the payer of the permit fee and the use of the fee itself. By placing permit fees into accounts dedicated by rider and tracking maintenance efforts and expenditures for individual facilities, it would be possible to demonstrate the use of specific permit program revenues for the maintenance of specific facilities. The more directly either of the above relationships can be established, the greater the chances for success. Unlike general tax revenues and utility charges, however, permit fees may only be used to finance the maintenance of new SWMFs.

It should also be noted that the use of dedicated accounts to deposit permit fees and the tracking of specific maintenance efforts and expenses will provide a valuable database for evaluating the ability of permit fees to cover program expenses as well as to determine any required revisions.

Similar to utility charges, the permit fee schedule should reflect the concept of payment based upon contribution to the need for facility maintenance rather than the benefits provided by it. For example, a SWMF construction permit fee may be based upon the size of the proposed facility as determined by area, height, and/or volume. The fee may also reflect the complexity of the facility's operation, including its use for both stormwater quantity and quality control. Therefore, a relatively small facility serving a residential area and intended only for quality control would be charged a proportionately lower permit fee than a larger facility providing both quality and quantity control to a commercial area.

COST DATA AND FINANCING TECHNIQUES

While a certain degree of complexity may be required to equitably distribute costs throughout the permit program, the fee schedule should also remain as simple as possible. As described for utility charges above, this simplicity will help make the fee schedule more understandable to the permit applicant and, as a result, more acceptable as well. The fee schedule should also retain a degree of flexibility in order to accommodate changes in program revenues, expenses, and responsibilities.

In addition, the fee schedule should reflect the costs of providing the recommended SWMF maintenance funding program operations itemized on Page 7. Based upon available data, such administrative and support costs are estimated to range from 10 to 20 percent of total program costs. Administrative costs of the permit program itself and the cost of necessary program liability insurance should also be included.

Finally, as described on Page 8, any SWMF maintenance funding program utilizing permit fees as a funding source should receive the review and approval of legal counsel and the certification of all appropriate State boards and agencies.

4. DEDICATED CONTRIBUTIONS

The use of dedicated contributions from land developers to finance public maintenance of SWMFs represents the extension of an established procedure in a new direction. Under the program, a municipal or county government would assume the maintenance of a SWMF constructed as part of a private land development. This maintenance may either be provided by municipal or county personnel or through a contract with a private maintenance service. All or a portion of the required funding for the maintenance would be obtained through a one-time contribution by the land developer to an account dedicated by rider which is controlled by the municipality or county.

The amount of the contribution to the dedicated account would be based upon several factors. They include:

1. The total number of years in which facility maintenance would be provided.
2. The present annual maintenance, administrative, insurance, and support costs.
3. The anticipated annual increase in present costs due to inflation, equipment depreciation and replacement, increases in labor and insurance rates, rising disposal costs, and other factors.

COST DATA AND FINANCING TECHNIQUES

4. The anticipated annual interest earned by the dedicated contribution.
5. The percentage, if any, of cost sharing between the developer and the municipality or county.

The total number of years for which maintenance will be provided will vary with each publicly funded SWMF maintenance program. A program developed by the Township of West Windsor in Mercer County, New Jersey is based upon the Township providing 25 years of maintenance for selected SWMFs built within the Township. At the end of the 25 year period, the maintenance will then be financed through the Township's general tax revenues. In the West Windsor program, participating developers are required to furnish 75 percent of the estimated annual SWMF maintenance costs in the form of a one-time payment. The amount of this payment is calculated for each facility through the use of a standardized Developer Contribution Worksheet. The details of this worksheet, provided courtesy of West Windsor Township, are presented in Table 6-3. A review of these details will serve to illustrate the Dedicated Contribution concept.

In the West Windsor program, annual maintenance costs are based upon the performance of four major maintenance tasks by Township personnel. These tasks include grass mowing, landscape maintenance, general maintenance such as trash and debris removal and erosion repair, and periodic sediment removal and bottom restoration. Grass mowing is estimated at the rate of one acre per hour. Other required tasks are estimated based upon an hourly, a yearly, or a per task basis. Appropriate factors are utilized to reflect the infrequent performance of such tasks as sediment removal and bottom restoration. Annual liability insurance costs are also estimated and combined with the estimated annual costs of the four major maintenance tasks to produce a total first-year maintenance cost for the facility. This value is multiplied by an appropriate Present Worth Factor and then by 0.75 to determine the actual amount of the dedicated contribution. This Present Worth Factor is based upon an average annual interest rate on the dedicated funds of 8 percent and an average annual cost increase of 6 percent over the 25 year maintenance period.

In addition to the features of the West Windsor program, the reader may also wish to include additional SWMF maintenance tasks presented in **Chapter Four - Maintenance Equipment and Procedures**, including periodic facility inspections, in the estimated annual cost calculations. The estimated cost data provided in Tables 6-1 and 6-2 can help to estimate the annual costs of these additional tasks. In addition, the annual cost calculations may also include the costs of providing the recommended SWMF maintenance funding program operations itemized on Page 7. Based upon available data, such

COST DATA AND FINANCING TECHNIQUES

administrative and support costs are estimated to range from approximately 10 to 20 percent of total program costs. Finally, an annual cost of approximately 2 percent of the dedicated funds may be required to cover the administrative costs of the dedicated accounts themselves.

The use of dedicated contributions to finance SWMF maintenance has many advantages. Unlike general tax revenues, contributions to dedicated accounts are not subject to the State "CAP" law. Although it is only applicable to new facilities, the use of such funds can be closely tracked through both account and expense records. This information can be utilized to demonstrate a direct relationship between the contributed funds and their use for facility maintenance. The use of separate accounts for each facility included in the maintenance program can further enhance this tracking capability, although with added administrative costs. Conversely, the use of a single or limited number of dedicated accounts will help reduce overall administrative costs at the expense of this tracking capability.

Finally, as described on Page 8, any SWMF maintenance funding program utilizing dedicated contributions as a funding source should receive the review and approval of legal counsel and the certification of all appropriate State boards and agencies.

F. SWMF MAINTENANCE COST SAVINGS

The design, construction, and operation of a successful SWMF requires input and coordination from many sources, including planning and design professionals, construction, inspection, and maintenance personnel, and regulatory agencies. As detailed throughout the **STORMWATER MANAGEMENT FACILITY MAINTENANCE MANUAL**, the degree and frequency of maintenance required at a SWMF is dependent upon the level of expertise and effort put forth by these concerns during their involvement with the facility. Therefore, it can be seen that these same concerns represent the source of SWMF maintenance cost savings.

As described in detail in **Chapter Two - Planning & Design Guidelines**, significant maintenance cost savings can be achieved through the use of effective standards, durable materials, and thorough analyses during the planning and design of a SWMF. Therefore, facility planners, designers, and reviewers should be encouraged to adopt and adhere to the recommendations and guidelines presented in Chapter Two of the **MANUAL**.

Sound construction of a SWMF in accordance with the design drawings and specifications will also help to reduce SWMF maintenance costs. Therefore, construction inspection offi-

COST DATA AND FINANCING TECHNIQUES

cialists should be encouraged to follow the recommendations included in **Chapter Three - Construction Inspection** to help insure the accuracy and soundness of the facility construction and to achieve the greatest possible maintenance cost savings.

Additional SWMF maintenance cost savings can be achieved through a comprehensive maintenance program that emphasizes preventative over corrective maintenance efforts. These cost savings can be seen in Table 6-2 by comparing the estimated labor cost to perform a maintenance task on a preventative basis with the estimated cost of the same task performed on a corrective basis. Therefore, to realize such cost savings, maintenance departments and staffs should be encouraged to follow the recommendations and procedures presented in **Chapter Four - Maintenance Equipment and Procedures**.

Finally, SWMF maintenance cost savings can be achieved through a comprehensive regulatory program that effectively guides the actions of the planners, designers, and construction, inspection, and maintenance personnel. Valuable cost saving information regarding such a regulatory program is presented in **Chapter Five - Regulatory Aspects**.

COST DATA AND FINANCING TECHNIQUES

TABLE 6-1

N.J. DEPARTMENT OF ENVIRONMENTAL PROTECTION
 STORMWATER MANAGEMENT FACILITY MAINTENANCE MANUAL

 SWMF MAINTENANCE EQUIPMENT AND MATERIAL COSTS

EFFECTIVE DATE: JUNE 1989

GRASS MAINTENANCE EQUIPMENT

	Purchase	Rent (per day)
	-----	-----
Hand Mower	\$300-\$500	\$25-\$40
Riding Mower	\$3,000-\$5,000	\$75-\$100
Tractor Mower	\$15,000-\$20,000	\$100-\$300
Trimmer/Edger	\$200-\$500	\$25-\$35
Spreader	\$100-\$200	\$20-\$30
Chemical Sprayer	\$200-\$500	\$25-\$40

VEGETATIVE COVER MAINTENANCE EQUIPMENT

	Purchase	Rent (per day)
	-----	-----
Hand Saw	\$15	\$5
Chain Saw	\$300-\$500	\$15-\$35
Pruning Shears	\$25	\$5
Shrub Trimmer	\$200	\$25-\$35
Brush Chipper	\$1000-\$5000	\$50-\$150

TRANSPORTATION EQUIPMENT

	Purchase	Lease	Rent
	-----	(per month)	(per day)
	-----	-----	-----
Van	\$10,000-\$15,000	\$400	\$50-\$70
Pickup Truck	\$10,000-\$15,000	\$400	\$50-\$70
Dump Truck	\$30,000-\$50,000	\$1200	\$75-\$150
Light Duty Trailer ..	\$3,000-\$5,000	\$150	\$30-\$50
Heavy Duty Trailer .	\$10,000-\$20,000	\$500	\$100-\$200

COST DATA AND FINANCING TECHNIQUES

TABLE 6-1 (CONTINUED)

DEBRIS, TRASH, AND SEDIMENT REMOVAL EQUIPMENT

	Purchase	Lease (per month)	Rent (per day)
Front End Loader ...	\$50,000-\$100,000	\$1500-\$2000	\$200-\$400
Backhoe	\$30,000-\$50,000	\$1200	\$150-\$300
Excavator	\$100,000+	\$2000+	\$400-\$1000
Grader	\$100,000+	\$2000+	\$400-\$1000

MISCELLANEOUS EQUIPMENT

	Purchase	Rent (per day)
Shovel	\$15	\$5
Leaf Rake	\$15	\$5
Soil Rake	\$15	\$5
Pick	\$15	\$5
Wheelbarrow	\$100-\$200	\$10
Gloves	\$5	N/A
Portable Compressor ...	\$500-\$1,000	\$50-\$100
Portable Generator	\$500-\$1,000	\$50-\$100
Concrete Mixer	\$500-\$1,000	\$25-\$50
Welding Equipment	\$500-\$1,500	\$35-\$70

MATERIALS

	Purchase
Topsoil	\$35/Cubic Yard
Fill Soil	\$15/Cubic Yard
Grass Seed	\$5/Pound
Soil Amenities (Fertilizer, Lime, etc.)	\$0.05/sq. ft.
Chemicals (Pesticides, Herbicides, etc.)	\$10/gallon
Mulch	\$25/Cubic Yard
Paint	\$20/Gallon
Paint Remover	\$10/Gallon
Machine/Motor Lubricants	\$5/Gallon
Dry Mortar Mix	\$4/50 Pound Bag
Concrete Delivered to Site	\$60-\$100/Cubic Yard

COST DATA AND FINANCING TECHNIQUES

TABLE 6-1 (CONTINUED)

NOTES:

1. Estimated equipment costs are based upon Industrial/Commercial grade equipment.

2. The cost estimates presented above are intended for general planning and comparison purposes. See text for information regarding the basis of the cost estimates, instructions regarding their recommended use, and procedures for developing more specific cost estimates where necessary.

3. See CHAPTER FOUR - MAINTENANCE EQUIPMENT AND PROCEDURES for additional information on SWMF maintenance equipment and materials.

COST DATA AND FINANCING TECHNIQUES

TABLE 6-2

**N.J. DEPARTMENT OF ENVIRONMENTAL PROTECTION
STORMWATER MANAGEMENT FACILITY MAINTENANCE MANUAL**

COSTS OF SWMF MAINTENANCE TASKS

EFFECTIVE DATE: JUNE 1989

PREVENTATIVE MAINTENANCE TASKS

(Values expressed in Man-Hours)

	<u>Small Facility</u>	<u>Large Facility</u>
Grass Cutting.....	1	1-2
Grass Maintenance.....	0.5	1
Trash & Debris Removal.....	0.5	1
Sediment Removal.....	4	8
Mobilization.....	1	1
Inspection & Reporting.....	1	2

CORRECTIVE MAINTENANCE TASKS

(Values expressed in Man-Hours)

	<u>Small Facility</u>	<u>Large Facility</u>
Trash & Debris Removal.....	4	8
Structural Repairs.....	24	40
Dewatering.....	4	8
Mosquito Extermination.....	1	2-4
Erosion Repair.....	4	8
Fence Repair.....	2-4	4-8
Snow & Ice Removal.....	1	2
Mobilization.....	2	2

COST DATA AND FINANCING TECHNIQUES

TABLE 6-2 (CONTINUED)

AESTHETIC MAINTENANCE TASKS

(Values expressed in Man-Hours)

	Small Facility	Large Facility
Grass Trimming.....	0.5	2
Weed Control.....	0.5	2
Landscape Maintenance.....	1-2	2-4
Graffiti Removal.....	2-4	4-8

NOTES:

1. Facility Size Definitions:

Small Facility: Total SWMF Site Area 1/4 Acre
 Large Facility: Total SWMF Site Area 1 Acre

Appropriate adjustments to the cost estimates presented above should be made as necessary to account for actual SWMF size. See text for further information.

2. Cost estimates are presented in terms of man-hours. These values should be used in conjunction with applicable personnel rates to determine labor costs for a specific program or facility.

3. The cost estimates presented above are intended for general planning and comparison purposes. See text for information regarding the basis of the cost estimates, instructions regarding their recommended use, and procedures for developing more specific cost estimates where necessary.

4. See Chapter Four - Maintenance Equipment and Procedures for detailed information regarding SWMF maintenance tasks listed above.

COST DATA AND FINANCING TECHNIQUES

TABLE 6-3

N. J. DEPARTMENT OF ENVIRONMENTAL PROTECTION
STORMWATER MANAGEMENT FACILITIES MAINTENANCE MANUAL

SAMPLE WORKSHEET FOR CALCULATING
DEDICATED CONTRIBUTION TO SWMF MAINTENANCE

EFFECTIVE DATE: DECEMBER 1988

NOTE:

The following worksheet is based upon a worksheet utilized by the Township of West Windsor, New Jersey to determine developer contributions to the Township's SWMF maintenance program. It is intended to illustrate the Dedicated Contribution funding concept. Appreciation is expressed to Township personnel for their assistance.

CALCULATION OF DEDICATED CONTRIBUTION

Through the use of the following Worksheet, total first-year SWMF maintenance costs are calculated. These first-year costs are then multiplied first by a Present Worth Factor of 19.79 and then by a factor of 0.75 to determine the amount of the developer's contribution, which will be equal to 75 percent of the total costs. This calculation provides for the receipt of sufficient funds for a twenty-five year maintenance period. This calculation also reflects an annual increase in maintenance costs of 6 percent.

The amount contributed by the developer will be placed into an account dedicated by rider which will be controlled by the Township. Interest earned by the funds are calculated at the rate of eight percent (8%) per year and are returned to the account.

The attached Worksheet provides for calculation of estimated annual maintenance costs for the SWMF. Variables (such as number of hours required to perform a maintenance function) are to be based upon a review by the Township's professional staff.

COST DATA AND FINANCING TECHNIQUES

TABLE 6-3 (CONTINUED)

WORKSHEET FOR DETERMINING DEVELOPER CONTRIBUTION
FOR
TOWNSHIP MAINTENANCE OF SWMFS

NAME OF DEVELOPMENT: _____

SECTION: _____

NUMBER OF ACRES INCLUDED AS PART OF SWMF: _____

1. MOWING

A. RATE PER HOUR FOR LABOR AND EQUIPMENT = \$ _____

B. BASE NUMBER OF HOURS FOR LABOR
AND EQUIPMENT FOR MOBILIZATION
AND MOWING UP TO ONE ACRE: _____

C. NUMBER OF HOURS FOR MOWING
ADDITIONAL AREA (BASED ON
ONE HOUR PER ACRE): _____

D. HOURS PER MOWING = B + C = _____

E. COST PER MOWING = A X D = \$ _____

F. NUMBER OF MOWINGS PER YEAR: _____

G. ANNUAL MOWING COST = E X F = \$ _____

H. MATERIALS = \$ _____

I. TOTAL COST = G + H = \$ _____

2. LANDSCAPE MAINTENANCE

A. RATE PER HOUR FOR LABOR AND EQUIPMENT = \$ _____

B. NUMBER OF HOURS OF REQUIRED
LANDSCAPE MAINTENANCE PER YEAR: _____

C. ANNUAL LANDSCAPE MAINT. COST = A X B = \$ _____

D. MATERIALS = \$ _____

E. TOTAL COST = C + D = \$ _____

COST DATA AND FINANCING TECHNIQUES

TABLE 6-3 (CONTINUED)

3. GENERAL MAINTENANCE

A. RATE PER HOUR FOR LABOR AND EQUIPMENT = \$ _____

B. NUMBER OF REQUIRED HOURS
OF GENERAL MAINTENANCE
PER OCCURRENCE: _____

C. COST PER OCCURRENCE = A X B = \$ _____

D. NUMBER OF OCCURRENCES PER YEAR: _____

E. TOTAL COST = C X D = \$ _____

4. INSURANCE

A. ANNUAL INSURANCE COST = \$ _____

TOTAL FIRST YEAR COST

1. MOWING (1.I.) = \$ _____

2. LANDSCAPE MAINTENANCE (2.E) = \$ _____

3. GENERAL MAINTENANCE (3.E.) = \$ _____

4. INSURANCE (4.A) = \$ _____

TOTAL FIRST YEAR MAINTENANCE COST = \$ _____

CALCULATION OF DEVELOPER CONTRIBUTION

A. TOTAL FIRST YEAR COST = \$ _____

B. FOR 25 YEARS = X 19.79

C. TOTAL REQUIRED AMOUNT = A X B = \$ _____

D. DEVELOPER CONTRIBUTION PERCENTAGE = X 0.75

E. DEVELOPER CONTRIBUTION = C X D = \$ _____

COST DATA AND FINANCING TECHNIQUES

TABLE 6-3 (CONTINUED)

ENGINEERING AND COST CALCULATIONS PREPARED BY:

TITLE: _____ DATE: _____

ADMINISTRATIVE REVIEW BY:

TITLE: _____ DATE: _____

COST DATA AND FINANCING TECHNIQUES

TABLE 6-4

**N.J. DEPARTMENT OF ENVIRONMENTAL PROTECTION
STORMWATER MANAGEMENT FACILITY MAINTENANCE MANUAL**

COST DATA AND FINANCING TECHNIQUES

SELECTED REFERENCES

1. Cyre, Hector J., "Developing a Stormwater Management Utility", APWA Reporter, March 1987.
2. Engemoen, Mark and Krempel, Roger E., "A Utility Approach to Comprehensive Storm Water Management", University of Kentucky, July 1983.
3. Stitt, Thomas A., "Establishing a Stormwater Management Utility", Public Works, September 1986.
4. Cyre, Hector, "Introduction to Stormwater Utility Financing", Water Resource Associates, Inc.
5. Cyre, Hector, "Stormwater Management Financing", Water Resource Associates, Inc.
6. Lindsey, Greg, "Stormwater Maintenance and Financing Options", Maryland Department of Natural Resources - Water Resources Administration - Stormwater Division, March 1987.
7. Poertner, Herbert G., "Stormwater Management in the United States", Stormwater Consultants, 1988.

Mailing List for Revisions to the
STORMWATER MANAGEMENT FACILITIES MAINTENANCE MANUAL

The Division of Water Resources may periodically update the Stormwater Management Facilities Maintenance Manual. To enable the Division to provide you with future revisions or amendments to this Manual, please complete the form below and return it to the address on the back.

Name: _____

Title: _____

Agency: _____

Address: _____

Telephone No.: _____

(Fold)

Affix
Stamp
Here

NJDEP
Division of Water Resources
Bureau of Water Quality Planning
CN-029
Trenton, New Jersey 08625

(Fold)

