

“Stormwater Detention” means a provision for temporary storage of stormwater runoff, and the controlled release of such runoff during and after a flood or storm.

“Stormwater Management Measures” means a broad term for structural and nonstructural control of stormwater runoff and nonpoint pollution.

“Stormwater Retention” means a provision for the permanent storage of a fixed volume of water.

“Street” means any street, avenue, boulevard, road, parkway, viaduct, drive, or other way which is an existing State, county, or municipal roadway, or which is shown upon a plat heretofore approved pursuant to law, or which is approved by official action as provided by the MLUL, or which is shown on a plat duly filed and recorded in the office of the county recording officer prior to the appointment of a planning board and the grant to such board of the power to review plats; and includes the land between the street lines, whether improved or unimproved, and may comprise pavement, shoulders, gutters, curbs, sidewalks, parking areas, and other areas within the street lines. (MLUL).

“Street Hardware” means the mechanical and utility systems within a street right-of-way such as hydrants, manhole covers, traffic lights and signs, utility poles and lines, parking meters, and the like.

“Street Hierarchy” means the conceptual arrangement of streets based upon function. A hierarchical approach to street design classifies streets according to function, from high-traffic arterial roads to streets whose function is residential access.

“Street, Loop” means a street that has its only ingress and egress at two points on the same street.

“Stub Street” means a street which is to be extended when the adjacent property is developed.

“Subdivision” means the division of a lot, tract, or parcel of land into two or more lots, tracts, parcels, or other divisions of land for sale or development. The following shall not be considered subdivisions within the meaning of these rules, if no new streets are created: divisions of land found by the planning board or subdivision committee thereof appointed by the chairman to be for agricultural purposes, where all resulting parcels are five acres or larger in size; divisions of property by testamentary or intestate provisions; divisions of property upon court order, including but not limited to judgments of foreclosure; consolidation of existing lots by deed or other recorded instrument; and the conveyance of one or more adjoining lots, tracts, or parcels of land owned by the same person or persons, all of which are found and certified by the administrative officer to conform to the requirements of the municipal development regulations, and are shown and designated as separate lots, tracts, or parcels on the tax map or atlas of the

municipality. The term “subdivision” shall also include the term “resubdivision.” (MLUL).

“Subdivision, Major” means any subdivision not classified as a minor subdivision. (MLUL).

“Subdivision, Minor” means a subdivision of land for the creation of a number of lots specifically permitted by ordinance as a minor subdivision, provided that such subdivision does not involve a planned development, any new street, or the extension of any off-tract improvement, the cost of which is to be prorated pursuant to N.J.S.A. 40:55D-42. (MLUL).

“Subgrade” means the prepared surface upon which pavements and shoulders are constructed.

“Surface Course” means the placement of the asphalt concrete material on a previously prepared base course.

“Swale” means a low lying or depressed land area commonly wet or moist, which can function as an intermittent drainage way.

“Topsoil” means:

1. The natural, undisturbed surface layer of soil having more organic matter than subsequent layers, a pH of 5.0 to 7.5, and suitable for satisfactory growth and maintenance of permanent, locally-adapted vegetation.
2. Where the original surface layer has been removed, the reapplication of soil material used to cover an area so as to improve soil conditions for establishment and maintenance of adapted vegetation. The reapplied material must be friable, loamy soil reasonably free of debris, objectionable weeds, and stones; have a natural pH of 5.0 to 7.5; have an organic matter content greater than 2.00 percent; and contain no toxic substances which may be harmful to plant growth.

“Traveled Way” means the portion of a cartway used for vehicular travel.

“Trip” means a single or one-way vehicle movement to or from a property or study area.

“ULI” means Urban Land Institute.

“USCGS (also USC&G and USC&GS)” means United States Coast and Geodetic Survey.

“Utility Area” means a flexible space within the right-of-way designated for the installation of utility lines and facilities.

“Utility Authority” means any “sewerage authority” as defined in N.J.S.A.40:14A-3 or any “municipal authority” as defined in N.J.S.A. 40:14B-3.

“Variance” means permission to depart from the literal requirements of a zoning ordinance, pursuant to N.J.S.A. 40:55D-40b., 70c., and 70d. (MLUL).

“Wet Pond” (see “retention basin”).

Administrative correction.

See: 29 N.J.R. 1296(a).

Amended by R.1999 d.374, effective November 1, 1999 (operative May 1, 2000).

See: 31 N.J.R. 477(a), 31 N.J.R. 3259(a).

Substituted “Where” for “There” at the beginning of the second sentence in the introductory paragraph; and in “Mountable curb”, deleted “flat” preceding “slope”.

5:21-1.5 Scope and applicability

(a) These rules shall govern any site improvements carried out or intended to be carried out or required to be carried out in connection with any application for residential subdivision, site plan approval, or variance before any planning board or zoning board of adjustment created pursuant to the Municipal Land Use Law (N.J.S.A. 40:55D-1 et seq.); or in connection with any other residential development approval required or issued by any municipality or agency or instrumentality thereof.

(b) Except as is otherwise specifically provided, these rules shall control all matters concerning the construction, alteration, addition, repair, removal, demolition, maintenance, and use of any site improvements constructed by a developer in connection with residential development. Except as otherwise required by rules or other permit requirements of the Department of Environmental Protection regarding storm water management, the rules are to be interpreted as the minimum required to ensure public health and safety, and the maximum that may be required in connection with residential development.

(c) These rules shall apply to all site improvement work and appurtenant construction including streets, roads, parking facilities, sidewalks, drainage structures, grading, and utilities which are undertaken by a developer in connection with residential development or use.

1. Where both residential and commercial development are planned in a mixed-use development, these rules shall apply to the residential part or parts of such development where such residential part or parts are discrete and separate from planned commercial parts as evidenced by, for example, separate building(s), separate parking, and separate access features.

2. These rules shall apply to all utilities created by or deriving their authority from municipal ordinance to operate within a given jurisdiction.

3. Choice among options contained in these rules shall be the applicant’s unless otherwise specified in these rules.

(d) Nothing contained in these rules shall be construed to limit the powers of any municipality to establish and enforce any requirement concerning:

1. Layout, arrangement, and location of improvements, shade trees, landscaping, or reservation of areas for public use, pursuant to N.J.S.A. 40:55D-38;

2. Preservation of existing natural resources; arrangement of physical elements for safe and efficient vehicular and pedestrian circulation, by, for example, traffic calming measures as described in “Residential Street Design and Traffic Control,” by W. S. Homburger et al. (Institute of Transportation Engineers, 1989), parking, and loading; screening, landscaping, and location of structures; or conservation of energy and use of renewable resources; pursuant to N.J.S.A. 40:55D-41; or

3. Use, bulk, height, number of stories, orientation, and size of buildings and other structures; the percentage of lot or development area that may be occupied by structures, lot sizes and dimensions, floor area ratios, or other measures to control development intensity; or the provision of adequate light and air pursuant to N.J.S.A. 40:55D-65.

(e) The provisions of these rules shall not preempt or in any way affect the exercise of any authority by the State or any county government with respect to site improvements conferred by any State law or any rule promulgated thereunder. Nor shall these rules be in any way interpreted to modify or otherwise affect rules promulgated pursuant to the Pinelands Commission Act, N.J.S.A. 13:18A-1 et seq. (N.J.A.C. 7:50). It is the intent of these rules to be consistent with all other applicable laws, rules and regulations. Where these rules and any other State or county laws, rules or regulations establish differing requirements, then the requirements of these rules shall govern, except where any such differing requirement is more restrictive.

(f) These rules shall not apply to driveways on private property held in fee-simple as individual residential lots outside of the public right-of-way, including common driveways established by easements shared by more than one dwelling unit on private property.

(g) These rules are intended to ensure the public health, safety, and welfare insofar as they are affected by site improvement work, and shall be so construed.

Administrative correction.

See: 29 N.J.R. 1296(a).

Amended by R.1998 d.399, effective August 3, 1998.

See: 30 N.J.R. 1660(a), 30 N.J.R. 2861(a).

In (b), inserted “Except as otherwise required by rules or other permit requirements of the Department of Environmental Protection regarding storm water management, the” at the beginning of the second sentence.

Case Notes

Department of Community Affairs' insignificant deviations from Model Subdivision and Site Plan Ordinance to be adopted pursuant to Residential Site Improvement Standards Act were within its incidental powers. *New Jersey League of Municipalities v. Department of Community Affairs*, 158 N.J. 211, 729 A.2d 21 (N.J. 1999).

Storm water management regulation promulgated by Department of Community Affairs (DCA), which conflicted with storm water management regulation promulgated by the Department of Environmental Protection, was invalid. *New Jersey State League of Municipalities v. Department of Community Affairs*, 310 N.J.Super. 224, 708 A.2d 708 (A.D.1998).

5:21-1.6 Development over limestone geologic formations

(a) A number of areas in northern New Jersey are underlain by solution-prone carbonate rocks (limestone, dolomite, and marble) which pose unusual and complex problems in relation to development activities. As such, these areas are quite sensitive to development improvements and may require special investigative, design, and construction techniques to protect both the eventual property owner as well as those in the immediate surroundings. It is not the intention of these site improvement standards to address such unusual subsurface conditions or to attempt to supersede definitive local ordinances addressing such concerns.

(b) Any proposed revisions to the standards established by the Site Improvement Advisory Board may be submitted for Board consideration by any municipality shown on the list set forth in the Appendix to this subchapter, incorporated herein by reference, or by any municipality where those materials are found to be present. Proposed revisions to the within standards shall be reviewed by the technical committee and recommended to the Site Improvement Advisory Board for approval.

Amended by R.1999 d.374, effective November 1, 1999 (operative May 1, 2000).

See: 31 N.J.R. 477(a), 31 N.J.R. 3259(a).

In (b), substituted a reference to Board consideration for a reference to consideration, and substituted a reference to the Appendix for a reference to Appendix 1-A.

5:21-1.7 Administration and enforcement

(a) Wherever a municipality has enacted an ordinance which requires subdivision and/or site plan approval pursuant to N.J.S.A. 40:55D-37, then the planning board of such municipality shall ensure that the plans and plats for any residential development subject to review under such ordinance comply with the requirements of these rules before issuing a preliminary or final approval.

(b) Whenever a zoning board of adjustment created pursuant to N.J.S.A. 40:55D-69 grants subdivision or site plan approval pursuant to the provisions of N.J.S.A. 40:55D-76(b), then that board shall ensure that any plans and plats comply with the requirements of these rules before issuing a preliminary or final approval.

Administrative correction.
See: 29 N.J.R. 1296(a).

5:21-1.8 Approval

(a) All materials, equipment, and devices required to be approved by a board or official pursuant to N.J.A.C. 5:21-1.7 shall be constructed and installed in accordance with such approval.

(b) The standards referenced in these rules and listed in N.J.A.C. 5:21-8 shall be considered a part of the requirements of these rules to the prescribed extent of each reference. Where differences occur between provisions of these rules and referenced standards, the provisions of these rules shall apply, except as provided in N.J.A.C. 5:21-1.5(e).

Administrative correction.

See: 29 N.J.R. 1296(a).

Administrative change.

See: 33 N.J.R. 691(b).

5:21-1.9 Violations

(a) Where any site improvement is required to meet any part of these rules pursuant to the requirements of any ordinance adopted pursuant to N.J.S.A. 40:55D-37, Subdivision and Site Plan Review and Approval, or N.J.S.A. 40:55D-62, Zoning, then any failure of any person to construct such site improvements in accordance with the requirements of these rules shall constitute a violation of the Municipal Land Use Law (N.J.S.A. 40:55D-1 et seq.). Any person responsible for such failure shall be subject to such penalties and enforcement procedures as are provided by that law and by any valid ordinance adopted pursuant thereto which may be initiated by the administrative officer designated by the ordinance (N.J.S.A. 40:55D-18).

(b) In addition to any remedy provided by (a) above, any failure to comply with the requirements of these rules, where compliance is required, shall constitute a failure to meet the conditions of the construction permit and/or certificate of occupancy issued pursuant to the State Uniform Construction Code Act (N.J.S.A. 52:27D-119 et seq.). Notification from the approving authority or from the municipal engineer acting on behalf of the approving authority that any of the requirements of these rules that are conditions of the Construction Permit and/or Certificate of Occupancy have not been met shall subject any person responsible for such failure to the remedies provided under the State Uniform Construction Code Act.

Administrative correction.

See: 29 N.J.R. 1296(a).

5:21-1.10 Operative date

(a) These rules shall be operative on June 3, 1997. The requirements of any municipal ordinances or rules adopted by any instrumentality deriving authority therefrom in effect on that date which establish rules or requirements for any matter within the scope of these regulations shall be deemed to have been repealed and of no further force or effect.

(b) Any project for which preliminary subdivision or site plan approval has been given prior to June 3, 1997 shall continue to be subject to the municipal development ordinance under which it was approved.

(c) Any project for which application is made after June 3, 1997 shall be governed by these rules.

(d) These rules shall not be construed as requiring the revision or amendment of any application for site plan or subdivision approval which is pending on June 3, 1997. Such pending applications may, however, be amended provided that any such amendments shall meet the requirements of these rules.

1. For any project for which a completed application has been submitted on or before the operative date of these rules, but which has not yet received preliminary approval, the applicant shall have the option of amending the application in its entirety to comply with these rules or of requesting that the municipality continue to review the application under the municipal ordinances in effect at the time of application.

5:21-1.11 Validity

If any provision of these rules or the application thereof to any person or circumstances is held invalid, the invalidity shall not affect other provisions or applications of the rules which can be given effect, and to this end the provisions of the rules are severable.

APPENDIX

**NEW JERSEY MUNICIPALITIES
LIMESTONE AREAS**

<u>County</u>		<u>Municipality</u>
Hunterdon	Alexandria Township Bethlehem Township Bloomsbury Borough Califon Borough Clinton Township Clinton Town	Hampton Borough Holland Township Lebanon Township Tewksbury Township Union Township
Morris	Chester Township Jefferson Township Mendham Township Mendham Borough Minehill Township Montville Township Morris Township	Mount Olive Township Mt. Arlington Borough Randolph Township Rockaway Township Roxbury Township Washington Township Wharton Borough
Passaic	Bloomingdale Borough Ringwood Township	Wanaque Borough West Milford Township
Somerset	Bedminster Township Far Hills Borough	Peapack/Gladstone Borough
Sussex	Andover Township Andover Borough Branchville Borough Byram Township Frankford Township Franklin Borough Fredon Township Green Township Hamburg Borough Hampton Township Hardyston Township	Lafayette Township Montague Township Newton Town Ogdensburg Borough Sandyston Township Sparta Township Stillwater Township Vernon Township Walpack Township Wantage Township
Warren	Allamuchy Township Alpha Borough Belvidere Township Blairstown Township	Independence Township Knowlton Township Liberty Township Lopatcong Township

County

Franklin Township
Frelinghuysen Township
Greenwich Township
Hackettstown Town
Hardwick Township
Harmony Township
Hope Township

Municipality

Mansfield Township
Oxford Township
Phillipsburg Township
Pohatcong Township
Washington Township
Washington Borough
White Township

† Listing established by the Department of Environmental Protection, Division of Science and Research (April 1995)

Administrative correction.
See: 29 N.J.R. 2816(a).

**SUBCHAPTER 2. APPLICATION AND REVIEW
PROCEDURES**

5:21-2.1 Application and review procedures

The procedure for municipal review and action on applications for residential subdivisions and/or site plans shall not be affected by anything contained in these rules, and shall continue to be as set forth in the Municipal Land Use Law (MLUL), N.J.S.A. 40:55D-1 et seq. and in municipal ordinances adopted pursuant to the MLUL. This review shall include a review for compliance with these rules.

5:21-2.2 Application form and checklist (Reserved)

**SUBCHAPTER 3. EXCEPTIONS, WAIVERS, AND
SPECIAL AREA STANDARDS**

5:21-3.1 Exceptions

(a) The municipal approving authority may grant such de minimis exceptions from the requirements of the site improvement standards as may be reasonable and within the general purpose and intent of the standards if the literal enforcement of one or more provisions of the standards is impracticable or will exact undue hardship because of peculiar conditions pertaining to the development in question.

(b) An application for an exception pursuant to this section shall be filed in writing with the municipal approving authority and shall include:

1. A statement of the requirements of the standards from which an exception is sought;
2. A statement of the manner by which strict compliance with said provisions would result in practical difficulties; and
3. A statement of the nature and extent of such practical difficulties.

(c) Exceptions shall become a part of the construction documents and shall be retained by the municipal approving authority.

(d) Within 30 days of granting a de minimis exception request, a municipal approving authority agreeing to an exception pursuant to this section shall send a copy of the document(s) constituting the de minimis exception resolution and/or document to the New Jersey Department of Community Affairs, Division of Codes and Standards, 101 South Broad Street, PO Box 802, Trenton, NJ 08625-0802. Such notice shall be clearly marked "Site Improvement Exception(s)."

(e) An application for an exception may also be made by an officer or agency of the municipality.

(f) Examples of de minimis exceptions include, but are not limited to, the following:

1. Reducing the minimum number of parking spaces and the minimum size of parking stalls;
2. Reducing the minimum geometrics of street design, such as curb radii, horizontal and vertical curves, intersection angles, centerline radii, and others;
3. Reducing cartway width; and
4. Any changes in standards necessary to implement traffic calming devices.

(g) The municipal approving authority's granting of a request for a de minimis exception shall be based on a finding that the requested exception meets the following criteria:

1. It is consistent with the intent of the Site Improvement Act;
2. It is reasonable, limited, and not unduly burdensome;
3. It meets the needs of public health and safety; and
4. It takes into account existing infrastructure and possible surrounding future development.

Administrative correction.
See: 29 N.J.R. 1296(a).

Case Notes

Department of Community Affairs (DCA) was authorized to adopt standards different from those contained in a Model Subdivision and Site Plan Ordinance if those standards were supported by any academic or professional institution or organization. *New Jersey State League of Municipalities v. Department of Community Affairs*, 158 N.J. 211, 729 A.2d 21 (N.J. 1999).

5:21-3.2 Waiver request

(a) A municipality or developer may, in connection with a specific development, request a waiver of any site improvement standard adopted under this chapter in accordance

with N.J.S.A. 40:55D-40.4(c). A waiver request may also be made jointly by a municipality and a developer.

(b) The Site Improvement Advisory Board may approve a request for a waiver based on any danger to public health and safety that would be caused by adherence to a standard specified in this chapter.

(c) A waiver may be requested by a municipality or a developer, or the request may be made jointly. The waiver request shall consist of the following:

1. A copy of the development application as submitted to the municipal approving authority; and
2. A brief memorandum to the Commissioner of the Department of Community Affairs containing sufficient information upon which to base a determination, including:
 - i. A short description of the project in narrative form;
 - ii. A citation to the particular site improvement standard from which waiver is requested;
 - iii. A clear description of the condition(s) giving rise to the request;
 - iv. A clear description of the anticipated result if the standard were to be followed;
 - v. The name, address, and telephone number of a contact person for the developer; and
 - vi. The name, address, and telephone number of a contact person for the municipal approving authority.

(d) The party requesting the waiver shall send the request to the New Jersey Department of Community Affairs, Division of Codes and Standards, 101 South Broad Street, PO Box 802, Trenton, NJ 08625-0802.

(e) Where a waiver is requested by the developer, the developer shall send a copy of the request to the administrative officer of the municipality concerned. Where a waiver is requested by the municipality, the municipality shall send a copy of the request to the developer.

(f) A waiver may be requested by the developer or the municipal approving authority at any time during the pendency of a development application. The Site Improvement Advisory Board recommends submission of a waiver request early in the application process or prior to the submission of a formal development application. If the applicant or the municipal approving authority determines during the planning board review process that a waiver request is appropriate, the municipal approving authority shall give consideration whenever possible to the granting of an extension for the purpose of pursuing a waiver. In some cases it may be impracticable for the party requesting or appealing a waiver to complete the waiver process within the time guidelines of the Municipal Land Use Law (N.J.S.A. 40:55D-1 et seq.;

see, for example, N.J.S.A. 40:55D-45.3, 46(c), 46.1, 47, 48 and 50). In such cases, the municipal approving authority may provide for the disposition of the waiver as a condition of its approval.

(g) There is no fee for requesting a waiver.

5:21-3.3 Waiver review

(a) The Commissioner shall review the waiver request to determine whether it appears on preliminary review that adherence to a particular standard would jeopardize the public health and safety.

1. If the waiver request on its face does not meet the requirements of this subsection, the Commissioner shall contact the requesting party within 20 days of receipt of the request and advise the requesting party of the waiver request rejection. Grounds for rejection shall be indicated in writing.

(b) Within 20 days of receipt of a waiver request, the Commissioner shall date and mark as justified for review each waiver request accepted for review. The Commissioner shall then direct each such waiver request to the Site Improvement Advisory Board's technical committee which consists of Board members who represent the New Jersey Society of Professional Engineers, the New Jersey Society of Municipal Engineers, and the New Jersey Builders Association (see N.J.S.A. 40:55D-40.4(c)).

(c) The Commissioner shall send notice of the Commissioner's determination of justification to designated contacts at the same time as the waiver request is sent to the technical committee.

(d) The technical committee shall render a decision by resolution within 30 days of the Commissioner's determination that the waiver request is justified.

(e) A waiver resolution adopted by the committee shall specify the grounds for granting or denying the waiver request.

(f) The Commissioner shall promptly notify the developer and the municipal approving authority of the committee's decision, and shall provide a copy of the resolution memorializing such decision to those parties and to the Site Improvement Advisory Board.

Amended by R.1999 d.374, effective November 1, 1999 (operative May 1, 2000).
See: 31 N.J.R. 477(a), 31 N.J.R. 3259(a).

5:21-3.4 Appeal of waiver decisions

(a) Any decision of the technical committee may be appealed to the Site Improvement Advisory Board, which shall hear appeals in public session at regularly scheduled or special meetings announced in compliance with the Open Public Meetings Act (see N.J.S.A. 10:4-6 et seq.).

(b) For each hearing, the Site Improvement Advisory Board shall designate, by simple majority of the members present, a voting member of the Board to serve as presiding officer.

(c) Any documents and materials constituting the appeal shall be available for public inspection at the Department of Community Affairs, Division of Codes and Standards during normal business hours at least 10 days before the date of the hearing. Other documents, records, or testimony may be produced at the hearing to clarify or supplement materials previously submitted.

(d) The hearings shall be informal. Rules of evidence shall not apply, but the presiding officer may exclude irrelevant, immaterial, or unduly repetitious evidence.

(e) The testimony of all witnesses in a waiver appeal shall be under oath or affirmation and shall be recorded verbatim either mechanically or stenographically. Transcripts may be obtained at the expense of the requesting party and shall be certified by the transcriber to be accurate.

(f) The Site Improvement Advisory Board shall render a final decision within 10 days of the hearing. The Board's decision shall be in writing, and shall contain findings and conclusions. The Board shall mail a copy of the decision to the developer and to the municipal approving authority.

5:21-3.5 Special area standards

(a) The Commissioner and the Site Improvement Advisory Board as a matter of policy recognize the need for preservation and/or enhancement of community character in New Jersey municipalities. This section is intended to provide a procedure whereby a municipal approving authority may develop and recommend to the Board supplementary and/or alternative standards in the form of municipal ordinances for review and amendment to this chapter. The Site Improvement Advisory Board shall solicit the input of the Department of Environmental Protection, the Office of State Planning, and the Department of Transportation and may solicit input from public or private organizations and individuals as it deems appropriate during the process of review of special area standards.

(b) A special area designation may be applied by ordinance by a municipality or group of municipalities to an area or areas of a municipality or municipalities exhibiting or planned to exhibit a distinctive character or environmental feature that the municipality or municipalities by ordinance have identified and expressed a desire to preserve and enhance. Examples of a special area may include:

1. Designated redevelopment areas pursuant to N.J.S.A. 40A:12A-1 et seq.;
2. Designated special improvement districts pursuant to N.J.S.A. 40:56-65 et seq.;

New Rule, R.1998 d.400, effective August 3, 1998.
See: 30 N.J.R. 755(a), 30 N.J.R. 2861(b).

SUBCHAPTER 4. STREETS AND PARKING

5:21-4.1 Street hierarchy

(a) Streets shall be classified in a hierarchy with design tailored to function. The street hierarchy definitions contained within this section are applicable only to local residential streets and are not to be considered related to the U.S. Department of Transportation, Federal Highway Administration's Functional Classification of Highways.

(b) The street hierarchy system shall be defined by road function and average daily traffic (ADT), calculated by trip generation rates from the current edition of "Trip Generation" by the Institute of Transportation Engineers, as indicated in Table 4.1 below. Trip generation rates from other sources may be used if the applicant demonstrates to the appropriate approving authority that these sources better reflect local conditions. In addition, the applicant shall investigate the opportunities for, and availability of, transit facilities and, if appropriate, consider their impact(s) on motor vehicle traffic trip generation rates per dwelling unit.

(c) Each residential street shall be classified and designed to meet the standards for one of the street types defined in Table 4.2 below. The entire length of the street need not be designed based on the highest ADT where the ADT varies along the street's length. However, each street segment between intersections shall be designed based on the highest ADT served in that segment.

(d) The municipality and the developer shall determine the highest order street required to be used in a given residential development, considering all of the following:

1. The size of the development (number and type of units). For example, using size to determine the highest order of street required, a development of up to 150 single-family detached units would not require any minor collectors or streets of a higher order;
2. The actual or potential development of adjacent sites (whether there is likely to be traffic passing through from neighboring developments). A "potential" development means a development having approvals granted, applications pending, or undergoing preliminary review; and
3. The streets proposed for that area, if any, as contained in the municipal master plan.

TABLE 4.1
AVERAGE DAILY MOTOR VEHICLE
TRAFFIC TRIP GENERATION
PER DWELLING UNIT

Land use	Peak rate
Single-family detached housing	10.2

Land use	Peak rate
Residential condominium/townhouse	5.9
High-rise residential condominium	4.3
Apartment	6.5
Low-rise apartment	7.2
Mid-rise apartment	5.5
High-rise apartment	5.0
Mobile home park	5.0
Retirement community	2.8
Recreational homes (owner occupied)	3.2

Note: The trip generation rates listed are guidelines only. The actual use of trip generation rates is derived by the use of regression analysis and should be computed only by professionals proficient in the use of the ITE Manual. The "Land Use" definitions are based on the ITE Manual with slight modifications to address inconsistencies contained within the ITE Manual.

Source: Institute of Transportation Engineers, Trip Generation (Washington, D.C.: ITE, 1982), 3rd Edition. The exhibit was updated with data from the 5th Edition of the manual published by ITE in January 1991. The peak ADT rates take into consideration Saturday and Sunday rates, as well as weekday rates.

DEFINITIONS

Land use	Definition
Single-family detached housing	Any single-family detached home on an individual lot.
Residential condominium/townhouse	Condominiums or townhouses in single-family ownership units that have at least one other single-family-owned unit within the same structure.
High-rise residential condominium/townhouse	Condominiums or townhouses in buildings that have three or more levels (floors).
Apartment	A rental dwelling unit located within the same building with at least three other dwelling units
Low-rise apartment	Apartments (rental dwelling units) in rental buildings that have one or two levels (floors), such as garden apartments.
Mid-rise apartment	Apartments (rental dwelling units) in rental buildings that have more than two levels (floors) and less than ten levels
High-rise apartment	Apartments (rental dwelling units) in rental buildings with ten or more levels (floors) and most likely with elevators
Mobile home park	Generally trailers shipped, sited, and installed on permanent foundations and in areas that typically have community facilities, such as recreation rooms, swimming pools, and laundry facilities.
Retirement community	Residential units similar to apartments and condominiums usually restricted to adults or senior citizens, and located in self-contained villages. Special services such as medical, dining,

<u>Land use</u>	<u>Definition</u>	<u>Recreational home</u>	<u>Dwellings usually located in a resort containing local services and complete recreational facilities. These are often second homes used by the owner or rented on a seasonal basis.</u>
	and retail facilities may be available.		

TABLE 4.2
RESIDENTIAL STREET HIERARCHY DEFINITIONS

<u>Street type</u>	<u>Description</u>	<u>Average daily traffic (maximum)</u>
Residential Access [‡]	<p>Lowest order, other than rural street type, of residential streets Provides frontage for access to lots and carries traffic with destination or origin on the street itself. Designed to carry the least amount of traffic at the lowest speed. All, or the maximum number of housing units, shall front on this class of street.</p> <p>[†] Residential access streets of "loop" configuration, that is, two ways out, should be designed so no section conveys an ADT greater than 1500. Each half of a loop street may be classified as a single residential access street, but the total traffic volume generated on the loop street should not exceed 1500 ADT, nor should it exceed 750 ADT at any point of traffic concentration.</p>	1,500 [†]
Residential Neighborhood [‡]	<p>A type of residential access street conforming to traditional subdivision street design, and providing access to building lots fronting on a street and parking on both sides of street.</p> <p>[‡] Applicant may choose either the RESIDENTIAL ACCESS or the RESIDENTIAL NEIGHBORHOOD street type for new streets. See section 4.8(b) for specific right-of-way and cartway width requirements for new streets that are a continuation of an existing street.</p>	
Minor Collector	<p>Middle order of residential street. Provides frontage for access to lots and carries traffic of adjoining residential access streets. Designed to carry somewhat higher traffic volumes than lower-order streets such as rural and residential access streets, with traffic limited to motorists having origin or destination within the immediate neighborhood. Is not intended to carry regional traffic.</p> <p>Each half of a loop-configured minor collector may be classified as a single minor collector street, but the total traffic volume conveyed on the loop should not exceed 3,500 ADT, nor should it exceed 1750 ADT at any point of traffic concentration.</p>	3,500
Major Collector	<p>Highest order of residential streets. Conducts and distributes traffic between lower-order residential streets and higher-order streets—arterials and expressways. Carries the largest volume of traffic at higher speeds. Function is to promote free traffic flow; therefore, parking should be prohibited and direct access to homes from this level of street should be avoided. Collectors should be designed so they cannot be used as shortcuts by non-neighborhood traffic.</p>	7,500
Special Purpose Streets		
Rural	<p>A rural street is one where density is one dwelling unit per acre or lower, AND the road primarily serves as access to abutting building lots, AND there is no on-street parking, AND lot-to-street access is designed so vehicles do not back out of lots onto the street.</p>	500
Rural residential lane	<p>A street serving a very low-density area (minimum two-acre zoning). The maximum ADT level limits the number of single-family units on this road to 20.</p>	200
Alley	<p>A service road that provides a secondary means of access to lots. On same level as residential access street, but different standards apply. No parking shall be permitted; alleys should be designed to discourage through traffic. ADT level shall not exceed that of a residential access street.</p>	500

Street type	Description	Average daily traffic (maximum)
Cul-de-sac	A street with a single means of ingress and egress and having a turnaround, the design of which may vary. A divided-type entrance roadway to at least the first cross street with median of sufficient width to insure freedom of continued emergency access by lanes on one side shall not be considered part of a cul-de-sac. Streets serving multi-family developments with a single means of ingress and egress and with shared parking facilities shall not be included within the definition of cul-de-sac.	250
Marginal access street	A service street that runs parallel to a higher-order street and provides access to abutting properties and separation from through traffic. May be designed as residential access street or minor collector, according to anticipated daily traffic.	1,500 (residential access total) 3,500 (minor collector total)
Divided street	Municipalities may require streets to be divided to provide alternate emergency access, protect the environment, or avoid grade changes. Design standards should be applied to the combined dimensions of the two street segments, as required by the street class.	
Parking loop	A street with non-parallel parking that provides circulation and direct vehicle access to parking from the travel lane.	

Administrative correction.
See: 29 N.J.R. 1296(a).
Amended by R.1999 d.374, effective November 1, 1999 (operative May 1, 2000).
See: 31 N.J.R. 477(a), 31 N.J.R. 3259(a).
In (c), added a second sentence; and in Table 4.2, added a third sentence in the Cul-de-sac Description, and substituted a reference to non-parallel parking for a reference to perpendicular parking in the Parking Loop Description.
Administrative correction.
See: 32 N.J.R. 684(b).

Intensity	Dwelling units per gross acre [†]
Low	Less than or equal to 4
Medium	More than 4 and less than or equal to 15
High	More than 15

Note: [†] In determining the intensity of development, the gross acreage shall not include dedicated common open space or other such areas restricted from future development.

5:21-4.2 Cartway width

(a) Cartway width for each street classification shall be determined by parking and curbing requirements that are based on intensity of development.

(b) Intensity of development shall be based on dwelling units per gross acre as follows:

(c) Cartway widths for each street classification are as shown in Table 4.3 below.

(d) Cartway width also shall consider possible limitations imposed by sight distances, climate, terrain, and maintenance needs.

TABLE 4.3
CARTWAY AND RIGHT-OF-WAY WIDTHS

Street type ^a	Total avg daily traffic	Traveled way	No. of parking lanes ^b	Parking lane width	Cartway width	Curb or shoulder ^h	Sidewalk or graded area ^j	Right-of-way width ⁱ
Residential Access	1,500 [†]							
Low intensity	†(loop-750 each half)	20 ft	1	8 ft	28 ft	none	1SW 1GA	50 ft
Medium		20 ft	1	8 ft	28 ft	curb	2 SW	50 ft
High (on-street parking)		20 ft	1	8 ft	28 ft	curb	2 SW	50 ft
High (off-street parking)		20 ft	0	0 ft	20 ft	none	2 SW	50 ft
Neighborhood (all intensities)	1,500	14 ft	2	16 ft	30 ft ^c	curb	2 SW	50 ft
Minor Collector	3,500							
Low intensity ^d with no parking		20 ft	0	0 ft	20 ft	none	1 SW 1GA	50 ft
Low with one								

parking lane		20 ft	1	8 ft	28 ft	curb	1 SW 1 GA	50 ft
Medium and High intensity ^d								
With one parking lane		20 ft	1	8 ft	28 ft	curb	2 SW	50 ft
With two parking lanes		20 ft	2	16 ft	36 ft	curb	2 SW	60 ft
With off-street parking		22 ft	0	0 ft	22 ft	curb or shoulder	2 SW	50 ft
Major Collector	7,500							
Low intensity		24 ft	0	0 ft	24 ft	none	2 SW	50 ft
Medium and High		24 ft	0	0 ft	24 ft	curb or shoulder	2 SW	50 ft if curb, 54 ft if shoulder
Special Purpose Streets								
Rural street ^k	500	20 ft	0	0 ft	20 ft	none	2 GA	40 ft
Rural lane ^k	200	18 ft	0	0 ft	18 ft	none	2 GA	40 ft
Alley (one way)					9 ft			11 ft
Alley (two way)		18 ft	0	0 ft	18 ft	none	2 GA	22 ft
Cul-de-sac (stem) ^e	250							
Marginal access street ^f								
Divided street ^g								
Parking loop								
One-side parking		24 ft	1	18 ft		curb		44 ft
Two-side parking		24 ft	2	36 ft		curb		62 ft

NOTES:

^aSee Table 4.2 for definitions of street hierarchy and N.J.A.C. 5:21-4.2 for definitions of low, medium, and high intensity of development.

^bParking lane refers to parallel parking; except in the case of parking loop, which is perpendicular parking.

^cThe 30 foot cartway would accommodate two eight foot parking lanes and one 14 foot moving lane.

^d20 foot minor collector cartways are permitted only when there is no direct building lot access to or from the street in question.

^eCartway and right-of-way widths of cul-de-sac stems and right-of-way requirements should conform to the applicable street type. Cul-de-sacs shall provide for a cartway turning radius of 40 feet and a right-of-way line eight feet beyond the edge of cartway.

^fCartway and right-of-way widths of marginal access streets and right-of-way requirements should conform to standards of either residential access or minor collector streets, as dictated by average daily traffic. If the classification is a minor collector requiring a 36 foot cartway, cartway width may be reduced to 28 feet since frontage is restricted to one side of the street.

^gCartway widths of divided streets should conform to standards of street classification, as dictated by anticipated average daily traffic, and be applied to aggregate dimensions of two street segments.

^hSee N.J.A.C. 5:21-4.3(c) for additional requirements.

ⁱRight-of-way width applies only to streets proposed for dedication as shown on approved plans.

^jSee N.J.A.C. 5:21-4.5(b) for additional requirements.

^kRural streets and rural lanes are permitted only within developments which do not exceed an average daily traffic count of 500 and 200 respectively.

^lAn additional 10 foot effective right-of-way on each side of the cartway shall be provided when sidewalks are required.

Administrative correction.

See: 29 N.J.R. 1296(a).

Amended by R.1999 d.374, effective November 1, 1999 (operative May 1, 2000).

See: 31 N.J.R. 477(a), 31 N.J.R. 3259(a).

In Table 4.3, combined Medium and High Intensity Street Types, changed Parking Loop Right-of-Way Widths, rewrote Note e, added "as shown on approved plans" at the end of Note i, and added Note l.

5:21-4.3 Curbs or curbs and gutters

(a) Curbs or curbs and gutters shall be used for drainage purposes, safety, and delineation and protection of pavement edge. Where, based on stormwater management system design, there is determined to be a problem with runoff, curbs or curbs and gutters shall be used.

(b) Curb requirements shall vary according to street hierarchy and intensity of development, in accordance with the requirements set forth in Table 4.3 in N.J.A.C. 5:21-4.2. Generally, curbs shall be required on streets with on-street parking.

(c) Where curbing is not required, edge definition and stabilization shall be furnished for safety reasons, and to prevent pavement unraveling. Curbing may be required for: stormwater management, road stabilization, delineation of parking areas, 10 feet on each side of drainage inlets, intersections, corners, and tight radii.

(d) Curb requirements may be waived by the appropriate municipal approving agency, and shoulders and/or drainage swales used when it can be shown that: shoulders are required by CAFRA; soil and/or topography make the use of shoulders and/or drainage swales preferable; and/or the community desires to preserve its rural character by using shoulders and/or drainage swales instead of curbs. In cases of medium development intensity, the curbing requirement may be waived where front setbacks exceed 40 feet and it can be demonstrated that sufficient on-site parking exists.

(e) A municipality may designate a curb type by ordinance. Where curb type is not established by municipal ordinance, flexibility regarding curb type shall be permitted as long as the curb type accommodates the system of drainage proposed. Generally, curbs should be constructed of concrete or granite block. Curbing materials shall accommodate the purposes set forth in (c) above.

(f) Curbs shall be constructed according to the specifications set forth in N.J.A.C. 5:21-4.17.

(g) Curbing shall be designed to provide a curb ramp in compliance with the Americans with Disabilities Act or the Barrier Free Subcode of the New Jersey Uniform Construction Code (N.J.A.C. 5:23-7) at street intersections, as applicable.

5:21-4.4 Shoulders

(a) Shoulders and/or drainage swales should be used instead of curbs when:

1. Shoulders are required by CAFRA;
2. Soil and/or topography make the use of shoulders and/or drainage swales preferable; and/or
3. To preserve rural character.

(b) Shoulders shall be provided in accordance with the requirements in Table 4.3 in N.J.A.C. 5:21-4.2.

(c) Shoulders shall be four feet wide, except for minor collector streets of high intensity with off-street parking, which shall be six feet wide on each side for all streets, and major collector streets of medium and high intensity, which shall be eight feet wide on each side for all streets. Shoulders shall be located within the right-of-way as shown in the following street illustrations.

(d) Shoulders shall be constructed of materials such as stabilized earth, gravel, crushed stone, bituminous treatment, or other forms of pavement which provide for vehicle load support.

Amended by R.1999 d.374, effective November 1, 1999 (operative May 1, 2000).
See: 31 N.J.R. 477(a), 31 N.J.R. 3259(a).
Rewrote (c).

5:21-4.5 Sidewalks and graded areas

(a) Sidewalks and/or graded areas shall be required, depending on road classification and intensity of development, in accordance with the requirements set forth in Table 4.3 in N.J.A.C. 5:21-4.2.

(b) Sidewalks shall be provided where graded areas are specified in Table 4.3 when the conditions described in (b)1 or 2 below exist:

1. The net density of the development or project exceeds one dwelling unit per acre; and

i. The development or project is located within 2,500 feet of a train station, public or school bus route;

ii. The development or project is located within 2,500 feet of an existing recreational, business or retail use or a site where such use is permitted by existing zoning; or

iii. Where the proposed streets connect to or extend existing streets which have sidewalks on both sides; or

2. The net density of the development exceeds .5 dwelling unit per acre and the development is located within two miles of a school.

(c) Notwithstanding (b)1 and 2 above, sidewalks shall only be required on one side of rural streets or rural lanes and shall not be required in alleys.

(d) Sidewalks shall be placed parallel to the street, as shown in the street profile figures, unless an exception has been permitted to preserve topographical or natural features, or if required to provide visual interest, or unless the applicant shows that an alternative pedestrian system provides safe and convenient circulation (for example, in planned development).

(e) Pedestrian-way easements at least 10-foot wide may be required by the municipal approving authority through the center of blocks more than 600-foot long. In providing circulation or access to schools, playgrounds, shopping, adjoining residential areas, or other community facilities, the municipality shall consider and may require pedestrian-way easements.

(f) Sidewalk width shall be four feet; wider widths may be necessary near pedestrian generators and employment centers. Where sidewalks abut the curb and cars overhang the sidewalk, widths shall be six feet. In high-density residential areas when sidewalks abut the curb, a sidewalk/graded area of at least six feet in width shall be required.

(g) Sidewalks and graded areas shall be constructed according to the specifications set forth in N.J.A.C. 5:21-4.18.

ILLUSTRATIONS OF STREET LAYOUTS FOLLOW:

Note: The individual components shown in the non-travel-way portion of the right-of-way such as utility areas, sidewalks, and graded areas are indicated for illustrative purposes only. Municipalities may vary the placement and dimensions of these individual items, depending on utility company requirements and local practice and preferences. In addition, items such as shade trees may be accommodated within the total right-of-way widths indicated for each street type. Several street types are not illustrated because of the limited or various, as the case may be, design possibilities.

5:21-4.6 Bikeways

(a) Separate bicycle paths and lanes shall be required only if such paths and lanes have been specified as part of a municipality's adopted master plan and/or official map.

(b) Bicycle lanes, where provided, shall be placed in the outside lane of a roadway, adjacent to the curb or shoulder. When on-street parking is permitted, the bicycle lane shall be between the parking lane and the outer lane of moving vehicles. Lanes shall be delineated with markings, preferably striping. Raised reflectors or curbs shall not be used.

(c) The construction of bikeways shall comply with the specifications set forth in N.J.A.C. 5:21-4.18.

5:21-4.7 Utility areas

(a) Utility mains shall be located within the right-of-way or within utility easements outside the right-of-way.

(b) Utility areas shall be planted with grass, ground cover, or treated with other suitable cover material.

Amended by R.1999 d.374, effective November 1, 1999 (operative May 1, 2000).

See: 31 N.J.R. 477(a), 31 N.J.R. 3259(a).

Rewrote (a).

5:21-4.8 Right-of-way and cartway

(a) The right-of-way shall be measured from lot line to lot line. Right-of-way requirements are shown in Table 4.3 in N.J.A.C. 5:21-4.2 and displayed graphically in the street illustrations in N.J.A.C. 5:21-4.5.

(b) The municipal approving authority may require the right-of-way and cartway widths of a new street that is a continuation of an existing street to be at least the same widths as the existing street.

(c) The right-of-way shall be of sufficient width to accommodate future development, as indicated by the municipal master plan.

(d) Where turning lanes are needed based on safety or capacity, additional right-of-way width, not to exceed the width and length of the turning lanes, may be required.

5:21-4.9 Street grade and intersections

Street grade and intersection design shall be constructed according to the specifications set forth in N.J.A.C. 5:21-4.19.

5:21-4.10 Pavement

(a) Street pavement thickness shall vary by street hierarchy, subgrade properties, and pavement type.

(b) Pavement design for rural, residential access, neighborhood, minor collector, and major collector streets shall conform to the specifications in N.J.A.C. 5:21-4.19.

5:21-4.11 Street and site lighting (Reserved)**5:21-4.12 Underground wiring**

(a) All electric, telephone, television, and other communication facilities, both main and service lines servicing new developments, shall be provided by underground wiring within easements or dedicated public rights-of-way, installed in accordance with the prevailing standards and practices of the utility or other companies providing such services.

(b) Lots that abut existing easements or public rights-of-way, where overhead electric or telephone distribution supply lines and service connections have heretofore been installed, may be supplied with electric and telephone service from those overhead lines, but the service connections from the utilities' overhead lines shall be installed underground.

(c) Overhead lines may be permitted as an exception by the municipal approving authority in areas of severe geological conditions. The placement and alignment of the poles shall be designed to lessen the visual impact of overhead lines.

5:21-4.13 Street and traffic signs

(a) Design and placement of traffic signs included in "Manual on Uniform Traffic Control Devices for Streets and Highways" shall follow the requirements specified in "Manual on Uniform Traffic Control Devices for Streets and Highways," published by the U.S. Department of Transportation and adopted by the N.J. Department of Transportation.

(b) At least two street name signs shall be placed at each four-way street intersection and one at each "T" intersection. Signs shall be placed so as not to obstruct sight distances and under light standards, if present, so that they are clearly visible. The design of street name signs should be: consistent, of a style appropriate to the community, of a uniform size and color, and erected in accordance with local standards.

(c) At signalized intersections, street signs shall be located on the overhead arm supporting the traffic signal, or otherwise suitably suspended over the intersection. Roadway clearance shall be a minimum of 15 feet from the bottom of any sign or supporting equipment and the top of the paved surface.

5:21-4.14 Parking: number of spaces

(a) An adequate number of on-street and off-street parking spaces shall be required in all developments to accommodate residents and visitors. For projects containing dwelling units required by the New Jersey Uniform Construction Code's Barrier Free Subcode (N.J.A.C. 5:23-7) to be accessible, accessible parking spaces for people with disabilities shall be provided in accordance with the require-

ments of the Barrier Free Subcode and shall be considered part of the total number of required spaces.

(b) For residential developments, parking shall be provided, as set forth in Table 4.4 below. If applicant does not specify the number of bedrooms per unit, note "c" for each category in Table 4.4 shall apply for the parking requirement.

(c) Alternative parking standards to those shown in Table 4.4 shall be accepted if the applicant demonstrates these standards better reflect local conditions. Factors affecting minimum number of parking spaces include household characteristics, availability of mass transit, urban versus suburban location, and available off-site parking resources.

(d) Garage and driveway combinations shall be counted as follows:

1. Each garage car space shall be counted as 1.0 off-street parking space regardless of the dimensions of the driveway.
2. A one-car garage and driveway combination shall count as 2.0 off-street parking spaces, provided the driveway measures a minimum of 18 feet in length between the face of the garage door and the right-of-way.
3. A two-car garage and driveway combination shall count as 3.5 off-street parking spaces, provided a minimum parking width of 20 feet is provided for a minimum length of 18 feet as specified for a one-car garage and driveway combination.

(e) When housing is included in mixed-use development, a shared parking approach to the provision of parking shall be permitted.

(f) When, in the judgment of the local approving authority, on-street parking is available, then only that proportion of the parking requirement which is not available on the street shall be provided in off-street parking facilities. A length of 23 feet per on-street parking space shall be used in calculating the number of available on-street parking spaces.

**TABLE 4.4
PARKING REQUIREMENTS FOR
RESIDENTIAL LAND USES^a**

Housing unit type/size ^b	Parking requirement
Single-Family Detached	
2 Bedroom	1.5
3 Bedroom	2.0
4 Bedroom	2.5 ^c
5 Bedroom	3.0
Garden Apartment	
1 Bedroom	1.8
2 Bedroom	2.0 ^c
3 Bedroom	2.1

Housing unit type/size ^b	Parking requirement
Townhouse	
1 Bedroom	1.8
2 Bedroom	2.3 ^c
3 Bedroom	2.4
High Rise	
1 Bedroom	0.8
2 Bedroom	1.3 ^c
3 Bedroom	1.9
Mobile Home	
1 Bedroom	1.8
2 Bedroom	2.0 ^c
Retirement Community	Values shall be commensurate with the most appropriate housing unit type and size noted above that the retirement community resembles.
Recreational Homes (owner occupied)	Values shall be commensurate with the most appropriate housing unit type and size noted above that the recreational homes (owner occupied) resemble.
Mid-Rise Apartment	"Garden Apartment" values shall apply.

Notes: ^a When determination of the required number of parking spaces results in a fractional space for the entire development, any fraction of one-half or less may be disregarded, while a fraction in excess of one-half shall be counted as one parking space. ^b Requirements for attached units (apartment/condominium/ townhouse) include provisions for guest parking. ^c If applicant does not specify the number of bedrooms per unit, this off-street parking requirement shall apply.

Source: Modified and adapted from U.S. Department of Commerce, Bureau of the Census, Public Use File—New Jersey (cross-tabulation of vehicles by housing unit for units constructed 1975 to 1980).

Amended by R.1999 d.374, effective November 1, 1999 (operative May 1, 2000).
See: 31 N.J.R. 477(a), 31 N.J.R. 3259(a).
Rewrote (d); and in Table 4.4, deleted "offstreet" preceding "parking" in Note c.
Administrative correction.
See: 32 N.J.R. 684(b).

5:21-4.15 Parking space size

Each off-street parking space shall measure nine feet in width by 18 feet in length. Parking spaces for people with disabilities shall be in accordance with the New Jersey Uniform Construction Code (N.J.A.C. 5:23) or the Americans with Disabilities Act, as applicable.

5:21-4.16 Parking areas

(a) Off-street parking areas shall be oriented to, and within a reasonable walking distance of, the buildings they are designed to serve.

(b) Access to parking lots shall be designed so as not to induce queues on travel ways, and to provide adequate pedestrian circulation and safety. There shall be adequate provision for ingress to and egress from all parking spaces to ensure ease of mobility, ample clearance, and safety of vehicles and pedestrians.

(c) The width of all aisles providing direct access to individual parking stalls shall be in accordance with the requirements specified in Table 4.5 below. Only one-way traffic shall be permitted in aisles serving single-row parking spaces placed at an angle other than 90 degrees.

TABLE 4.5

PARKING ANGLES AND AISLE WIDTHS

<u>Parking angle</u> <u>(degrees)</u>	<u>Aisle width</u> <u>(feet)</u>
30	12
45	13
60	18
90	24

(d) Where sidewalks occur in parking areas, parked vehicles shall not overhang or extend over the sidewalk unless

an additional two feet of sidewalk width are provided to accommodate such overhang.

5:21-4.17 Curb construction standards

(a) Construction specifications for acceptable curb types of granite block and concrete are shown in Figure 4.1 below.

(b) The standard concrete curb section used shall be a maximum of 20 feet in length, with a scored joint every 10 feet. All concrete used for curbs or combination curbs and gutters shall be prepared in accordance with the requirements, by class of concrete, of the New Jersey Department of Transportation, *Standard Specifications for Road and Bridge Construction*, effective at the time of preparation. Where bituminous concrete pavement is used for the road surface, the curb and/or gutter shall be constructed first.

(c) Where drainage inlets are constructed but curbs are not required, curbing must be provided at least 10 feet on each side of the inlet, set back one foot from the extension of the pavement edge.

Administrative correction.
 See: 29 N.J.R. 1296(a).
 Amended by R.1999 d.374, effective November 1, 1999 (operative May 1, 2000).
 See: 31 N.J.R. 477(a), 31 N.J.R. 3259(a).
 Administrative correction.
 See: 32 N.J.R. 684(b).

FIGURE 4.1
(1 of 5)

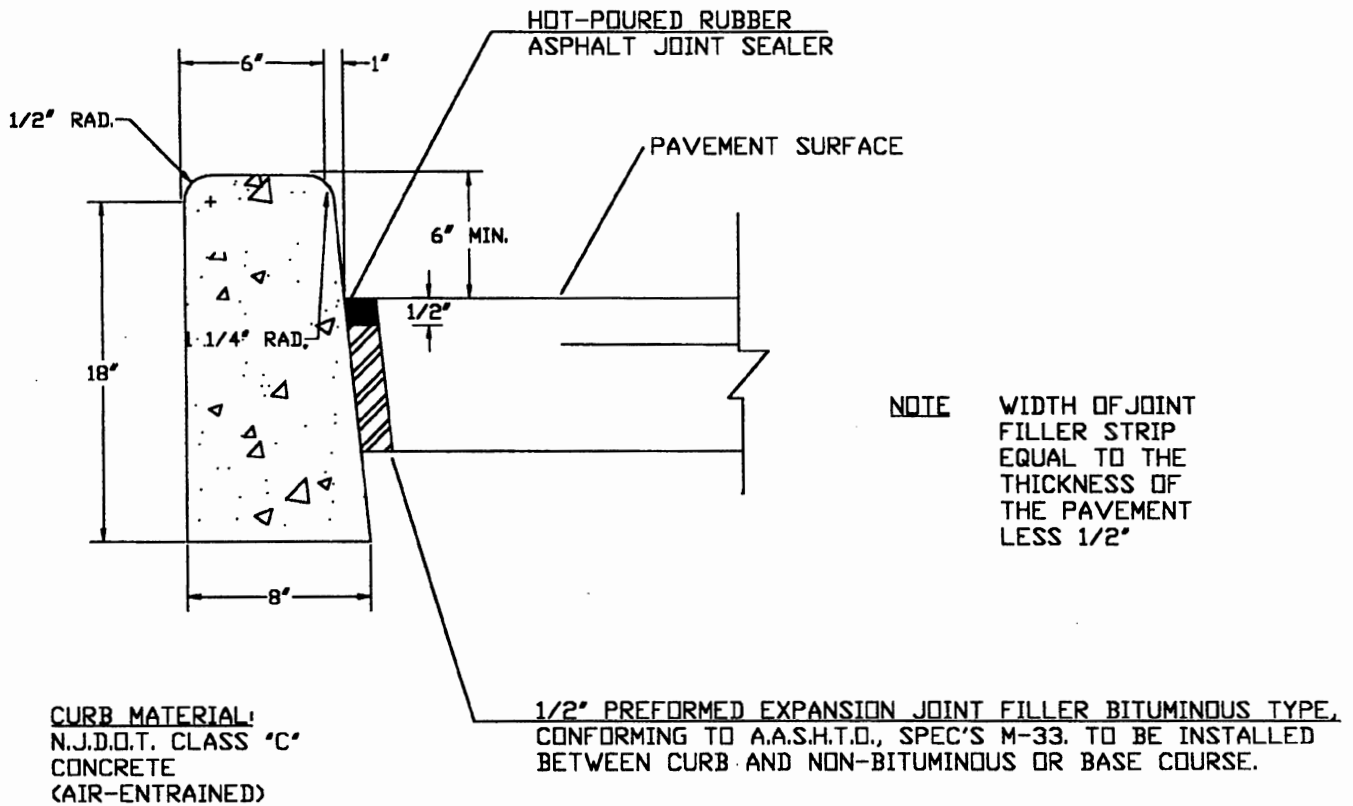

TRANSVERSE JOINTS 1/2" WIDE SHALL BE INSTALLED IN THE CURB 20'-0" APART AND SHALL BE FILLED WITH PREFORMED, BITUMINOUS-IMPREGNATED FIBER JOINT FILLER, COMPLYING WITH THE REQUIREMENTS OF A.A.S.H.T.O. SPEC. M-213, RECESSED 1/4" IN FROM FRONT FACE AND TOP OF CURB.

CONCRETE VERTICAL CURB

FIGURE 4.1
(4 of 5)

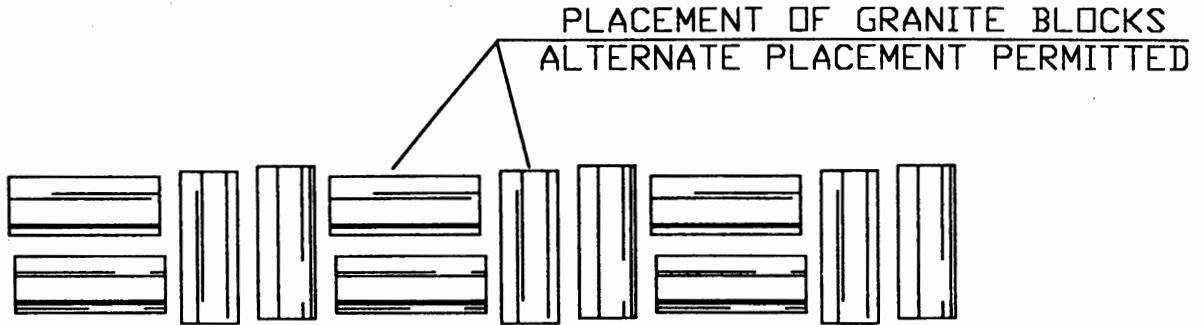

PLAN

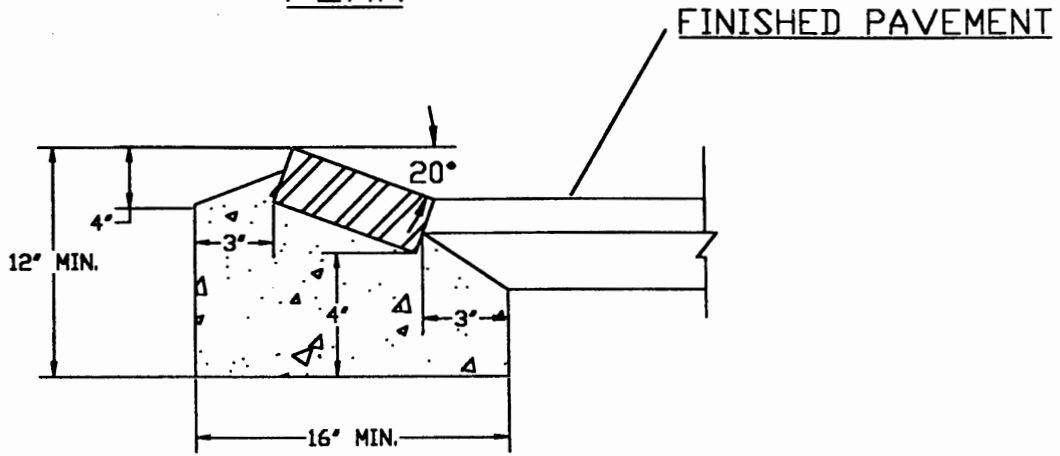

SECTION

MOUNTABLE GRANITE BLOCK CURB

FIGURE 4.1
(5 OF 5)

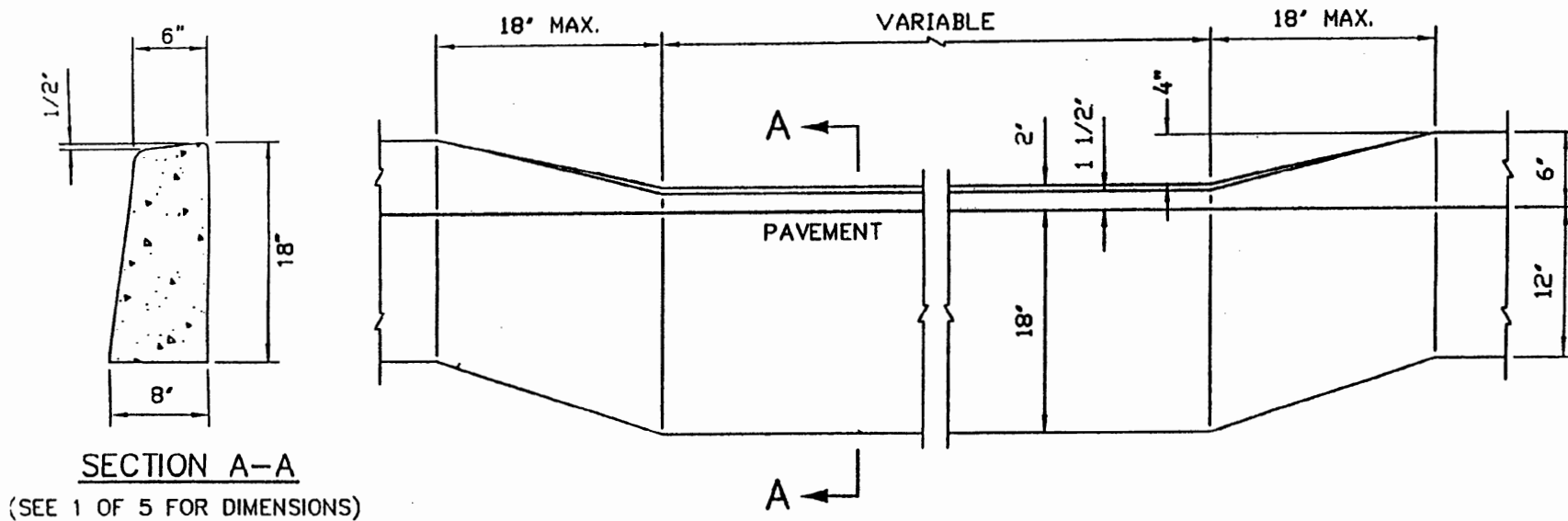

DROP CURB AT DRIVEWAYS

DETAIL SHOWN FOR CONCRETE CURB. DETAIL FOR GRANITE BLOCK DROP CURB SHALL FOLLOW SAME DIMENSIONS IN THE DRIVEWAY AREA.

5:21-4.18 Sidewalks and bikeways construction standards

(a) The following apply to sidewalks and graded areas:

1. Sidewalks of concrete shall be four inches thick except at points of vehicular crossing, where they shall be at least six inches thick. At vehicular crossings, concrete sidewalks shall be reinforced with welded wire fabric mesh or an equivalent.

2. Concrete air-entrained sidewalks shall be Class C concrete, having a 28-day verification strength of 4000 p.s.i. Other materials may be permitted, depending on the design of the development.

3. Graded areas shall be planted with grass or treated with other suitable ground cover, and their width and cross slope shall correspond to that of sidewalks.

(b) The following apply to bikeways:

1. The paved width of the bicycle path shall be established by the municipal master plan.

i. Choice of surface materials, including bituminous mixes, concrete, compacted gravel, soil cement, stabilized earth, and wood planking shall depend on use and users of the path.

ii. Gradients of bike paths should generally not exceed five percent.

2. Bicycle-safe drainage grates shall be used in the construction of all residential streets.

Administrative correction.
See: 29 N.J.R. 1296(a).

5:21-4.19 Street grade, intersections, pavement, and lighting construction standards

(a) The following apply to street grade:

1. Minimum street grade permitted for all streets shall be 0.5 percent.

2. Maximum street grade shall vary by road hierarchy with flatter grades required for roads with higher ADTs, in accordance with the requirements shown in Table 4.6. Where terrain makes it necessary, the allowable maximum grade may be increased by up to two percent, but shall not exceed a maximum grade of 16 percent.

(b) The following shall apply to intersections:

1. Street intersections shall be as nearly at right angles as possible and in no case shall be less than 75 degrees.

2. New intersections along one side of an existing street shall, if possible, coincide with an existing intersection on the opposite of each street. Where provided, offsets shall be at least 150 feet between right-of-way centerlines.

3. Intersections shall be rounded at the curbline with the street having the highest radius requirement, as shown in Table 4.6 below, determining the minimum standard for all curb lines.

4. Intersections shall be designed with a flat grade wherever practical.

5. The minimum centerline radius, minimum tangent length between reverse curves, and curb radii shall be as shown in Table 4.6 below.

6. Sight triangles shall be in accordance with 1990 AASHTO's "A Policy on Geometric Design of Highways and Streets" standards and based on the speed limits established by the government agency having jurisdiction. Sight triangle easements shall be required and shall include the area on each street corner that is bounded by the line which connects the sight or "connecting" points located on each of the right-of-way lines of the intersecting street. The planting of trees or other plantings, or the location of structures exceeding 30 inches in height that would obstruct the clear sight across the area of the easements, shall be prohibited, and a public right-of-entry shall be reserved for the purpose of removing any object, material or otherwise, that obstructs the clear sight.

TABLE 4.6
STREET GRADE AND INTERSECTION DESIGN CRITERIA

	Street Hierarchy				
	Special purpose street: alley	Special purpose street: cul-de-sac	Rural, residential access, and neighborhood	Minor collector	Major collector
Minimum Grade	0.5%	0.5%	0.5%	0.5%	0.5%
Maximum Grade	15%	12%	12%	10%	8%
Maximum Grade of Secondary Street within 50 feet of Intersection†	5%	5%	5%	5%	5%
Minimum Center-Line Radius	100 ft	100 ft	100 ft	150 ft	300 ft
Minimum Tangent Length between Reverse Curves	0 ft	50 ft	50 ft	100 ft	150 ft

	Special purpose street: <u>alley</u> 20 ft	Special purpose street: <u>cul-de-sac</u> 25 ft	Rural, residential access, and <u>neighborhood</u> 25 ft	<u>Minor collector</u> 30 ft	<u>Major collector</u> 35 ft
Curb Radii					
Note: †As measured from the nearest right-of-way line.					

(c) Pavement design for residential access, neighborhood, rural, parking loop, minor collector, and major collector shall follow the specifications shown in Figures 4.2 and 4.3 below. Subgrade categories are shown in Table 4.7 below.

(e) Lighting (Reserved)

(d) Alternative pavement design shall be allowed provided it conforms with one of the following: AASHTO Method of Flexible Pavement Design, Caltrans Method of Flexible Pavement Design, Asphalt Institute Method, AASHTO Method of Rigid Pavement Design, Fatigue Strength Method of Design, Multilayer Elastic Analysis, or the National Crushed Stone Association Design, incorporated herein by reference.

FIGURE 4.2

PAVEMENT SECTIONS FOR LOCAL STREETS
(Residential Access, Neighborhood, Rural or Parking Loop)

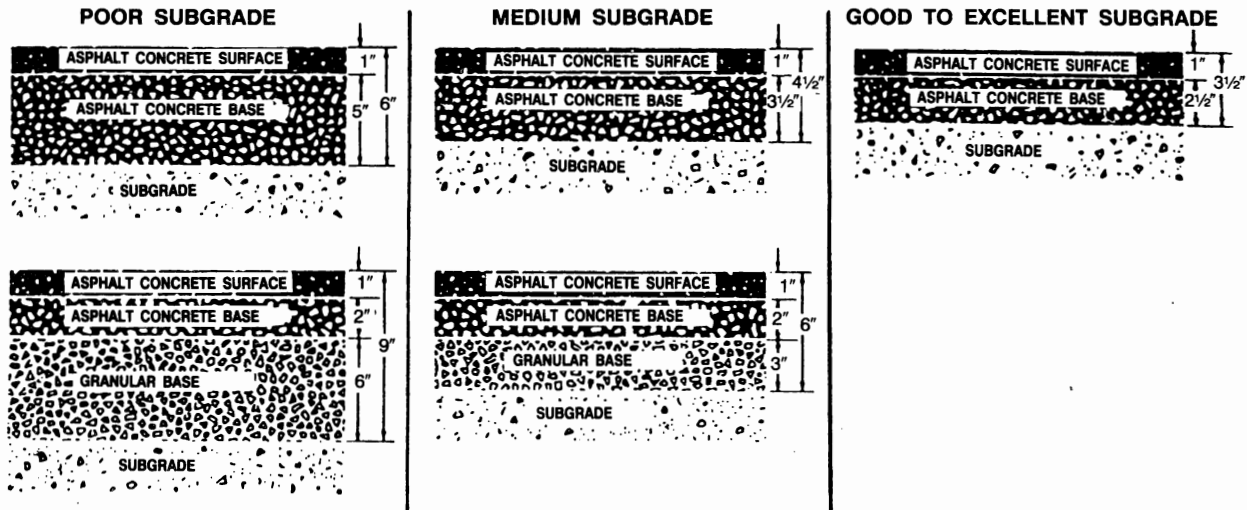

Source: New Jersey Society of Municipal Engineers, Asphalt Handbook for County and Municipal Engineers (Trenton, NJ NJSME, 1991).

NOTES:

1. The granular base shall be dense graded aggregate conforming to subsection 901.08 or soil aggregate designated I-5 conforming to subsection 901.09 and shown in Table 901-2 of the N.J. Department of Transportation standard Specifications for Road and Bridge Construction (1989).
2. All subgrades shall be considered "poor" unless the applicant proves otherwise through CBR testing or field evaluation of soil classification. Test results shall be reviewed by the Municipal Engineer.
3. Subgrade compaction shall be approved by the Municipal Engineer.

FIGURE 4.3

PAVEMENT SECTIONS FOR COLLECTOR STREETS
(Minor and Major)

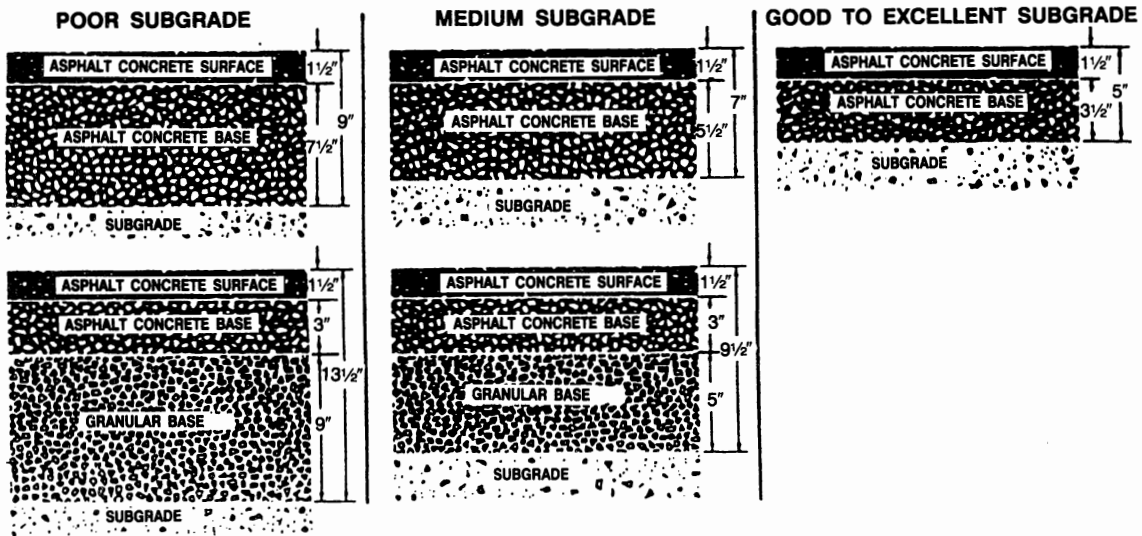

Source: New Jersey Society of Municipal Engineers, Asphalt Handbook for County and Municipal Engineers (Trenton, NJ NJSME, 1991).

NOTES:

1. The granular base shall be dense graded aggregate conforming to subsection 901.08 or soil aggregate designated I-5 conforming to subsection 901.09 and shown in Table 901-2 of the N.J. Department of Transportation standard Specifications for Road and Bridge Construction (1989).
2. All subgrades shall be considered "poor" unless the applicant proves otherwise through CBR testing or field evaluation of soil classification. Test results shall be reviewed by the Municipal Engineer.
3. Subgrade compaction shall be approved by the Municipal Engineer.

TABLE 4.7

SUBGRADE CATEGORIES

A. BASED ON STRENGTH TEST

<u>Subgrade category</u>	<u>California Bearing Ratio (Cbr)</u>	<u>Resilient Modules Mr Value</u>
Good to excellent	+10	Above 15,000
Medium	+5 to 9	7,500 to 13,500
Poor	2 to 4	3,000 to 6,000

B. BASED ON SOIL CLASSIFICATION

Subgrade category	Material	Unified System ^a	AASHTO System ^a
Good to excellent	Gravels and sands	GW, GP, GM, GC, SW, SP, SM, SC	A-1, A-2-4, A-2-5, A-2-6, A-2-7, A-3
Good or poor	Silts and clays	ML, CL, OL, MH, CH, OH	A-4, A-5, A-6, A-7-5, A-7-6

Notes: ^a Refers to categories of soil types and properties.

Sources: Per the Rutgers Model Subdivision and Site Plan Ordinance by David Listokin and Carole W. Baker, January 1987—Original strength test and soil classification information derived from the Asphalt Institute, ***Thickness Design—Full-Depth Asphalt Pavement Structures for Highways and Streets***, MS-1, 8th Edition, August 1970 in Robert F. Baker et al. (editor), Handbook of Highway Engineering. Inclusion of SW, SP, SC soil classifications based on information from the Portland Cement Association’s Thickness Design for Concrete Highway and Street Pavements.

Revised CBR strength test and Mr value information are from the Asphalt Handbook for County and Municipal Engineers, November 1991 (Second Edition), published by the New Jersey Society of Municipal Engineers.

Administrative correction.

See: 29 N.J.R. 1296(a).

Administrative correction.

See: 29 N.J.R. 2816(a).

Amended by R.1999 d.374, effective November 1, 1999 (operative May 1, 2000).

See: 31 N.J.R. 477(a), 31 N.J.R. 3259(a).

Rewrote (b)2; and in Table 4.6, deleted Intersection Standard heading, and substituted a reference to Maximum Grade of Secondary Street for a reference to Maximum Grade.

5:21-4.20 Curves

(a) Vertical and horizontal curves shall be designed in accordance with 1990 AASHTO’s “A Policy on Geometric Design of Highways and Streets” standards, incorporated herein by reference.

(b) Sight easements on vertical and horizontal curves shall be required and determined based on the sight distance requirements contained in the 1990 AASHTO’s “A Policy on Geometric Design of Highways and Streets” standards, taking into consideration the speed limits established by the government agency having jurisdiction. Residential access, residential neighborhood, and rural street design should be based on a speed limit of 25 miles per hour. Minor and major collector street design should be based on a speed limit of 30 miles per hour.

(b) When plans for future development necessitate over-sizing of the water supply system, the municipality or utility authority may enter into an agreement with the developer to address the fair share of the costs.

(c) The demand rates for all uses shall be considered in computing the total system demand. Where fire protection is provided in accordance with (e) below, the system shall be capable of providing the required fire demand plus the required maximum daily residential demand, or the peak hour flows indicated in Table 5.2 below, whichever is greater. The maximum daily demand shall be calculated by multiplying the average daily residential demand indicated in Table 5.1 by a factor of 1.5.

(d) Average daily residential consumption shall be computed in accordance with the housing unit type and size data shown in Table 5.1. The peak daily flows shall be computed by applying a peaking factor of three times the average daily residential consumption. The municipality may require deviations in the peaking factor value provided appropriate documentation and justification for the deviation from the standards is provided.

(e) The design of the on-site water distribution system shall be adequate to provide fire protection as per ISO standard, *Fire Suppression Rating Schedule*, or per AWWA M31, “Manual of Water Supply Practices—Distribution System Requirements for Fire Protection,” ISO method on pages 3-9, incorporated herein by reference.

SUBCHAPTER 5. WATER SUPPLY

5:21-5.1 Water supply system

Water supply systems, where installed, shall conform to the standards contained in this subchapter.

5:21-5.2 Capacity

(a) The water supply system shall be adequate to handle the necessary flow, based on complete development of the tract.

TABLE 5.1
WATER DEMAND/GENERATION BY
TYPE /SIZE OF HOUSING

Type/size housing	Number of residents	Residential Water Demand ^a (daily) (gallons per day)
Single-family detached 2 bedroom	2.13	215

Type/size housing	Number of residents	Residential Water Demand ^a (daily) (gallons per day)
3 bedroom	3.21	320
4 bedroom	3.93	395
5 bedroom	4.73	475
Garden Apartment		
1 bedroom	1.57	120
2 bedroom	2.33	175
3 bedroom	3.56	270
Townhouse		
1 bedroom	1.69	125
2 bedroom	2.02	150
3 bedroom	2.83	210
4 bedroom	3.67	275
High-rise		
studio	1.07	80
1 bedroom	1.34	100
2 bedroom	2.14	160
Mobile home		
1 bedroom	1.73	130
2 bedroom	2.01	150
3 bedroom	3.47	260

Notes: ^a Based on 100 gallons per person per day for single-family detached units and 75 gallons per person per day for other housing types (rounded).

Source: U.S. Census, Public Use File—New Jersey (Units built 1975-1980).

TABLE 5.2

DESIGN STANDARDS FOR PEAK HOUR FLOW

Total houses served	Peak hourly rates (gallons per minute per house)
5	8.0
10	5.0
50	3.0
100	2.0
250	1.3
500	0.8
750	0.7
1,000 or more	0.6

Amended by R.1999 d.374, effective November 1, 1999 (operative May 1, 2000).

See: 31 N.J.R. 477(a), 31 N.J.R. 3259(a).

Rewrote (c); and in Table 5.2, added Peak Hourly Rate for 1,000 or more Total Houses Served.

5:21-5.3 System design and placement

(a) System design and placement shall comply with the following construction specifications, incorporated herein by reference: all applicable NJ Department of Environmental Protection (NJDEP) rules, the American Water Works Association (AWWA) standards, and in the Pinelands Area, the Standards of the Pinelands Comprehensive Management Plan, with the strictest standards governing.

(b) Distribution mains of the overall system shall be connected into loops so that the supply may be brought to the consumer from more than one direction. In balancing loops in a design, the Hardy-Cross, or an equivalent, method shall be used (see subchapter Appendix, incorporated herein by reference). Manning roughness coefficients listed in Table 7.1 in N.J.A.C. 5:21-7.1 may be used in these calculations. Dead-end lines shall be permitted within the design of a looped system provided that there are no more than 20 dwelling units permanently, or no more than 50 dwelling units temporarily, on a dead-end line. When dead-end lines are used, they shall be provided with a hydrant or blowoff at the terminus as a means of flushing.

(c) Valves, except on a permitted dead end, shall be located on distribution mains so that no more than one hydrant would be out of service as a result of a single water main break. They shall be located in all small branches off larger mains; and where eight-inch or larger mains lines intersect, a valve shall be located in each branch. At street intersections, valves shall be located near pipe intersections for ease in finding in the event of a water main break.

(d) In addition to the above requirements, water mains shall be valved so that not more than one-quarter of a mile would be affected by a single water main break. Geared valves on 16-inch mains or larger shall be furnished.

(e) Gate valves shall be cast-iron body with double-disc gates, bronze mounted conforming to AWWA C500 or resilient-seated wedge, non-rising stem mechanical joint conforming to AWWA C509. Butterfly valves shall conform to AWWA C504. The type of valve to be used shall be as specified by the municipality or utility authority. Valve interior openings shall be full size, and valves on 16-inch mains or larger shall be geared and have suitable bypasses. Valve boxes shall be of the adjustable type with the cover marked "water" and direction of valve operation indicated.

(f) No pipe shall be placed on private property unless the owner of the land is to own or operate the pipe, or an easement deeded to the municipality or utility authority is obtained. All easements shall be a minimum of 20-foot wide unless depth of pipe, soil conditions, or additional utilities require wider. Where the easement is located adjacent to a right of way, the municipality or authority may approve a narrower easement.

(g) A building service connection shall be comprised of a corporation stop at the main, a curb stop, and a water meter. When the meter is located outside a building, an additional shut-off valve shall be installed on the discharge side of the meter. When the meter is located inside a building, valving shall be in accordance with the Plumbing Subcode of the Uniform Construction Code (N.J.A.C. 5:23-3.15). Curb stops and water meters shall be located as specified by the public or private water supplier.

1. Separate water service connections for each unit shall be utilized for detached housing where maintenance is the responsibility of the individual homeowner.

2. Common water service connections shall be allowed for multifamily housing where there is an entity, such as a homeowner's association, that is responsible for the maintenance of the common water laterals. Where common laterals are utilized, individual water shutoffs and meters shall be provided for each unit.

(h) Where water system extensions are constructed by developers and meter fees are not paid by the developer, the water meter(s) shall be furnished by the developer and shall be of a manufacture and type approved by the municipality or utility authority. The meter(s) shall read in volume units as determined by the municipality or utility authority. Where meter fees are paid by the developer, the meter(s) shall be furnished by the municipality or utility authority.

(i) Pipe size shall comply with the following requirements:

1. Water mains shall be a minimum diameter of eight inches except at the end of a permanent cul-de-sac, unless another size is required for fire flow and other criteria. A six-inch main may be used when it serves not more than 20 dwelling units and only one fire hydrant.

2. Building service connection pipe shall be a minimum diameter of three-quarter inch.

3. Design capacity of water mains shall be such as to maintain a minimum pressure of 20 pounds per square inch (psi) at street level under all flow conditions.

(j) Pipe materials used in the construction of water mains shall be cement-lined ductile iron, prestressed concrete cylinder pipe, reinforced concrete pressure pipe, or PVC pipe. All pipe and appurtenances shall comply with the applicable AWWA standards in effect at the time of application. All standards referenced in this subsection are incorporated herein by reference.

1. Ductile iron pipe, appurtenances, and fittings shall comply with ANSI/AWWA C110/A21.10 (fittings), C111/A21.11 (gasket joints), C115/A21.15 (flanged joints), and C151/A21.51 (pipe). Thickness shall be designed in accordance with ANSI/AWWA C150/A21.50. It shall be cement-mortar lined in accordance with ANSI/AWWA C104/A21.4. Joints shall be gasketed push-on joints or mechanical joints in conformance with ANSI/AWWA C111/A21.11. The exterior of the ductile iron pipe shall be covered with an asphaltic epoxy-type coating. In aggressive soils, ductile iron pipe wrapped in polyethylene in accordance with ANSI/AWWA C105/A21.5 shall be used.

2. Prestressed concrete cylinder pipe with rubber and steel joints shall conform to ANSI/AWWA C301; reinforced concrete pressure pipe (steel cylinder type) shall meet ANSI/AWWA C300; concrete pressure pipe (bar

wrapped steel cylinder type) shall meet ANSI/AWWA C303.

3. PVC pipe, appurtenances, and fittings shall conform to ANSI/AWWA C900 for pipe sizes four inches to 12 inches and shall conform to AWWA C905 for sizes 14 inches through 36 inches. Joints shall be elastomeric-gasket couplings of a corresponding size. Laboratory performance requirements, as specified in ASTM D3139, shall be met. Solvent-cement couplings shall not be permitted. PVC pipe installations shall be provided with a metallic locator tape.

4. Where transitions to flanged fittings are made, adapters approved by the municipality or water purveyor shall be used.

5. Building service connection pipe shall be type K copper or polyethylene (PE) pressure pipe that complies with ANSI/AWWA C901.

(k) Pipe bedding and backfill shall be installed in accordance with the pipe manufacturer's recommendations.

1. The municipality or the authority may require the developer to provide an opinion of a professional engineer relative to the suitability of the on-site material to be used as backfill. The municipality or authority shall rely on this opinion.

2. Where the on-site material is deemed suitable, the opinion shall specify the appropriate installation methods for the material. Where the on-site material is deemed not suitable, the opinion shall specify modification or replacement of the material and the appropriate installation for the specified material.

Amended by R.1999 d.374, effective November 1, 1999 (operative May 1, 2000).

See: 31 N.J.R. 477(a), 31 N.J.R. 3259(a).

Inserted a new (e); recodified former (e) through (j) as (f) through (k); in the new (f), added a third sentence; in the new (h), substituted a reference to volume in units for a reference to gallons and cubic feet; and rewrote the new (j).

5:21-5.4 Fire hydrants

(a) Hydrants shall be spaced to provide necessary fire flow. The average building area served per hydrant shall not exceed 120,000 square feet. In addition, the distance between any dwelling and a hydrant shall not exceed 400 feet when measured along the street right-of-way.

(b) Size, type, and installation of hydrants shall conform to the following specifications, incorporated herein by reference, as appropriate:

1. Size, type, and installation of hydrants shall be in accordance with the requirements of the municipality or the water purveyor or shall conform to the AWWA Standard for Dry Barrel Fire Hydrants, ANSI/AWWA C502. Hydrants shall have at least three outlets; one outlet shall be a pumper outlet; the other outlets shall be at least two-and-one-half-inch nominal size. The pumper

outlet shall face the street. All outlet nozzles shall be at least 12 inches above the adjoining grade. When a concrete slab is provided around the hydrant riser, the flange where the hydrant connects to the riser shall be at least two inches above adjacent grade. Street main connections shall not be less than six inches in diameter. Hose threads on outlets shall be compatible with existing municipal equipment and shall either conform to NFPA 1963 or shall match existing municipal requirements. A valve shall be provided on connections between hydrants and street mains. All pipe, fittings, and appurtenances supplying fire hydrants shall be AWWA or ASTM approved.

2. All fire hydrants shall conform to NFPA Standard 291.

Amended by R.1999 d.374, effective November 1, 1999 (operative May 1, 2000).

See: 31 N.J.R. 477(a), 31 N.J.R. 3259(a).

Rewrote (b)1.

APPENDIX

HARDY-CROSS METHOD

The Hardy-Cross method is a trial-and-error method in which the adjustments to be made in the assumed values are computed and are therefore controlled. Convergence of errors is often rapid, and sufficient precision in the results can ordinarily be had by three adjustments. Two methods may be used: the method of balancing heads or the method of balancing flows. The method of balancing heads is as follows:

1. Assume any distribution of discharge.
2. Compute the head loss in each element by means of Eq. (1): $h = kq_0^x$.
3. With due attention to sign, compute the total head loss around each elementary closed circuit: $\Sigma h = \Sigma kq_0^x$.
4. Compute also for each elementary circuit without reference to sign the sum: $\Sigma xkq_0^{(x-1)}$.
5. To balance the head in each circuit (so that $\Sigma kq^x = 0$), set up a counterbalancing flow equal to

$$\Delta = \frac{\Sigma kq_0^x \text{ (with due attention to direction of flow)}}{\Sigma xkq_0^{(x-1)} \text{ (without reference to direction of flow)}} \quad (4)$$
6. Compute the revised flows, and repeat the process until the desired accuracy is obtained.

The flow correction Δ for each circuit places the heads for that circuit substantially in balance if Δ is small. Since some elements of each circuit are common to other circuits, however, the balance of heads in each circuit is disturbed by subsequent adjustments in other circuits. Hence several traverses of the system are required before satisfactory precision is obtained. The proof of the method is as follows:

$$q = q_0 + \Delta$$

in which q = actual discharge for any element

q_0 = assumed discharge

Δ = required flow correction

Then

$$kq^x - k(q_0 + \Delta)^x = k(q_0^x + xq_0^{(x-1)}\Delta + \dots)$$

The remaining terms in the preceding expansion may be neglected if Δ is small as compared with q_0 . For a single circuit,

$$\Sigma kq^x = 0$$

and from above,

$$\Sigma kq^x = \Sigma kq_0^x + \Delta \Sigma xkq_0^{(x-1)}$$

Therefore,

$$\Delta = - \frac{\Sigma kq_0^x}{\Sigma xkq_0^{(x-1)}} \quad (4)$$

If Δ is large compared with q_0 , Eq. (4) does not give a close approximation of the value of Δ because of the neglect of the terms beyond the second term in the expansion. This neglect is not usually important, however, particularly if subsequent adjustments bring rapid convergence.

SUBCHAPTER 6. SANITARY SEWERS

5:21-6.1 Sanitary sewer system

(a) Sanitary sewer systems, where installed, shall conform to the standards contained in this subchapter.

(b) When plans for future development necessitate oversizing or grade changes, the municipality or utility authority may enter into an agreement with the developer to address the fair share of the costs of improvements not required for the proposed development.

(c) If a public sanitary sewer system will be provided to the area within a six-year period as indicated in the municipal sewer master plan, official map, or other official document, a municipality may require installation of a capped system within the road right-of-way or existing utility authority easements to service the approved lots; or, alternatively, a municipality may require a performance guarantee in lieu of the improvement. Capped sanitary sewers shall be allowed only in areas indicated for sewer service in the State of New Jersey Statewide Water Quality Management (WQM) Plans and where permitted by NJ DEP through sewer connection approval.

(d) Individual subsurface disposals systems shall comply with N.J.A.C. 7:9A-3.2 and 3.16.

(e) The applicant shall submit to the municipality or utility authority for review for compliance with this subchapter details of the planned pipes, joints, mains, laterals, and appurtenances. All materials used for sanitary sewer systems shall be manufactured in the United States, wherever available, as governed by P.L. 1982, c.107, effective date October 3, 1982. The details shall comply with all standards and specifications listed in this subchapter.

5:21-6.2 System planning, design and placement

(a) The planning, design, construction, installation, modification, and operation of any treatment works or sanitary sewer system shall be in accordance with the flow and design criteria set forth in N.J.A.C. 7:14A-23 and with the applicable NJDEP rules implementing the New Jersey Water Pollution Control Act (N.J.S.A. 58:10A-1 et seq.) and the New Jersey Water Quality Planning Act (N.J.S.A. 58:11A-1 et seq.); and, for items not covered by NJDEP rules, with ASCE Manual on Engineering Practice No. 60, incorporated herein by reference; and, in the Pinelands Area, with the Pinelands Comprehensive Management Plan and, in the coastal area, with NJDEP rules implementing the Coastal Area Facilities Review Act (N.J.S.A. 13:19-1 et seq.). Where the NJDEP accepts reduced flows, those reduced flows shall also be accepted under these rules.

(b) Sanitary sewer pumping stations shall be considered where gravity system design leads to excessive sewer depths which are not economically justifiable and shall comply with N.J.A.C. 7:14A-23.10, 11 and 12.

(c) System design and placement shall comply with the following specifications:

1. Except where otherwise specified by municipality or utility authority, sanitary sewer manholes, when located within the municipal right-of-way, shall be at or near the center line of the paved cartway, but at a five-foot minimum from the edge of the pavement. Sanitary sewer mains shall be a minimum of 10 feet from the right-of-way line.

2. Easements shall be in a form approved by the utility authority or the municipal engineer and municipal attorney. Easements shall be required for all sanitary sewer lines which are not within a public right-of-way. Easements shall be a minimum of 20 feet wide for sanitary sewers that are not more than 15 feet deep. For sewers that are more than 15 feet deep, easements shall be a minimum of 30 feet wide. The depth of the sewer shall be measured from the design invert of the pipe to the surface of the proposed final grading. Where the easement is located adjacent to a right of way, the municipality or authority may approve a narrower easement.

3. As with water lines, common sanitary sewer service may be permitted for multifamily housing where there is

an entity such as a homeowner's association that is responsible for the maintenance of the common laterals.

4. All sewers shall be designed to meet the New Jersey Department of Environmental Protection's slope standards at N.J.A.C. 7:14A-23.6(b).

5. Except where shallower depths are permitted by the municipality or utility authority, sewer lines, including force mains and laterals, shall be constructed at least three feet below the proposed grade (as measured from the top of the pipe to the grade elevation).

6. Pipe materials used in the construction of gravity sanitary sewers shall be reinforced concrete, ductile iron, PVC, or clay pipe. All pipe and appurtenances shall comply with AWWA and ASTM standards referenced in this paragraph, which are incorporated herein by reference.

i. Reinforced concrete pipe shall be used only in sizes 24 inches and larger and shall meet all the requirements of ASTM C76. All pipe shall be Class III strength installed with class C ordinary bedding, except in the following conditions where stronger pipe may be required:

(1) For depths less than three feet, measured from the top of the pipe, installed under traffic areas, Marston Class IV pipe shall be required.

(2) The presence of clay soils, poor bedding conditions, or other unusual loading conditions shall be given special consideration and the developer shall submit an engineering analysis to the municipality or authority for approval.

ii. PVC sewer pipe shall have bell and spigot ends and O-ring rubber gasketed joints, PVC pipe and fittings shall conform to ASTM D3034, with a minimum wall thickness designation of SDR 35 or shall conform to ASTM F679, F789, F794, or F949 with a designated pipe stiffness of PS-46.

(1) The plastic material from which the pipe and fittings are extruded shall be impact types of PVC, unplasticized, having high mechanical strength and maximum chemical resistance conforming to Type 1, Grade 1 of the specification for rigid polyvinyl chloride compounds, ASTM D1784.

(2) Pipe shall be free from defects, such as bubbles or other imperfections, in accordance with accepted commercial practice. Test results demonstrating that the pipe meets ASTM D2444 for impact and ASTM D2321 for deflection and pipe stiffness, shall be provided when requested by the municipality or utility authority.

(3) Joints shall conform to ASTM D3212. Rubber ring gaskets shall conform to ASTM F477. The gasket shall be the sole element depended upon to make the joint watertight.

(4) The pipe shall be installed as specified in ASTM D2321. In no case shall less than a Class III material be used for bedding and haunching material, unless approved in writing by the municipal engineer or utility authority engineer. When installing pipe in unstable soil or excessive ground water, a determination regarding special precautions, such as poured concrete slabs, shall be made by the municipal engineer or utility authority engineer.

(5) Trench cross sections shall comply with the bedding details at Figure 6.1 below.

iii. Ductile iron pipe shall be centrifugally cast in metal or sand-lined molds to ANSI/AWWA C151/A21.51. Joints shall be rubber gasketed joints that conform to ANSI/AWWA C111/A21.11 or flanged joints that comply with ANSI/AWWA C115/A21.15. Pipe shall be a minimum of Class 50. The outside of the pipe shall be coated with a uniform thickness of hot applied asphaltic coating. In corrosive soils, pipe shall be encased in polyethylene in accordance with ANSI/AWWA C105/A21.5. Ductile iron pipe shall be installed with Class C, Ordinary Bedding, when site conditions allow. The inside shall be lined with cement in accordance with ANSI/AWWA C104/A21.4 or, where hydrogen sulfide is present, ductile iron pipe with polyethylene coating that protects the interior of the pipe shall be used.

iv. Clay pipe shall comply with ASTM C700.

7. Inverted siphons and outfalls shall be constructed of ductile iron pipe or PVC pipe, as specified above. Inverted siphons shall consist of a minimum of two pipes with provisions for flushing. Flow control gates shall be provided in the chambers.

8. Force mains shall be designed in accordance with the requirements of N.J.A.C. 7:14A-23. Force mains shall be constructed of ductile iron pipe, as specified above, or PVC pipe that meets ASTM D1785 or ASTM D2241.

9. In addition to the pipe materials at N.J.A.C. 7:14A-23.6(b)5, PVC pipe shall be considered a suitable material.

10. For other than PVC pipe, pipe and manhole bedding shall be provided as specified in "Gravity Sanitary Sewer Design and Construction, ASCE Manual and Reports on Engineering Practice No. 60," prepared by the Joint Task Force of the American Society of Civil Engineers and Water Pollution Control Federation, New York, 1969. Any pipe material not covered by this manual shall be installed in accordance with the manufacturer's recommendations.

i. The municipality or the authority may require the developer to provide an opinion of a professional engineer regarding the suitability of the on-site material to be used as backfill. The municipality or authority shall rely on this opinion.

ii. Where the on-site material is deemed suitable, the opinion shall specify the appropriate installation methods for the material. Where the on-site material is deemed not suitable, the opinion shall specify modification or replacement of the material and the appropriate installation methods for the specified material.

11. Manholes shall comply with the standards in ASCE Manual on Engineering Practice No. 60, and shall meet the following requirements.

i. Manholes shall be precast concrete or concrete block. Manhole barrels shall be a minimum of four feet in diameter when serving sewers 24 inches or less in diameter, and shall be a minimum of five feet in diameter when serving sewers greater than 24 inches in diameter. Where manholes are precast, the base and first section shall be monolithically cast. Concrete block shall be coated with two coats of Portland cement mortar. Precast concrete or concrete block shall be sealed with two coats of an acceptable waterproofing tar, asphalt, or polyplastic alloy, with enough time allowed between the seal coats to bond.

ii. Masonry brick, concrete block, or half rings may be used to make vertical adjustments to rims.

iii. Where pipe size varies, crowns of pipes shall be matched, except in special conditions, as required by applicable NJDEP rules.

iv. If precast manhole barrels and cones are used, they shall conform to ASTM C478, with round rubber gasketed joints conforming to ASTM C443. Maximum absorption shall be nine percent, in accordance with ASTM C478, method A. Cracked manholes shall not be used. The top riser section of precast manholes shall terminate less than 18 inches below the finished grade to provide for proper adjustment.

v. Manhole frames and covers shall be of cast iron and shall conform to ASTM A48, Class 30, and shall be suitable for H-20 loading capacity. All manhole covers in unpaved rights-of-way or in remote areas shall be provided with a locking device, as specified by the municipality or utility authority. The word "SEWER" shall be cast integrally into the manhole cover.

vi. Manholes shall be supplied with flexible, water-tight adapters, such as inserts or gaskets, conforming to ASTM C923 and suitable for the pipe materials used.

vii. Masonry units shall conform to the following requirements:

(1) Clay or shale brick shall conform to AASHTO M114, grade MW, with the following modifications:

(A) The length of the brick shall be not less than 7.75 inches and shall be not more than 8.25 inches. The width of the brick shall be not less than 3.50 inches and not more than 3.88 inches. The depth of the brick shall be not less than 2.10 inches and not more than 2.38 inches.

(B) The maximum water absorption, by five hour boiling, shall be 14 percent based on the average of five bricks, and shall be 16 percent for individual bricks.

(2) Concrete block shall be solid, precast segmental concrete masonry units. Portland cement shall conform to ASTM C150. Concrete block shall conform to the following dimensional requirements:

(A) The blocks shall be either rectangular in shape, or shall be curved blocks with the inside and outside surfaces curved to the required radii, whichever is appropriate to the shape of the structure. The length shall be not less than 12 inches and not more than 18 inches. The height shall be not less than five inches and not more than eight inches. The width shall be not less than eight inches. Blocks of special shapes and heights may be used to allow for the reduction of cross sectional area at the cones or tops of manholes, or may be used in the top courses of all structures so that the head castings shall be set at the required elevation on a mortar bed not more than one-half inch thick without cutting the blocks. All blocks shall have an interlocking-type joint at the ends, so as to form a strong, rigid structure. All blocks shall be sound and free from all cracks or other defects.

(3) Concrete brick shall conform to the requirements of vii(2)(A) above except that the dimensions shall conform to the requirements for clay or shale brick in vii(1)(A) above.

12. Laterals and cleanouts shall comply with the following:

i. The house connection or lateral from the street main to the cleanout shall be considered an integral part of the sanitary sewer system. The type of material used for the house connection shall be as follows: four-inch cast iron soil pipe, extra heavy; four-inch PVC pipe, Schedule 40 or SDR 35; four-inch ABS plastic pipe, SDR 35; or four-inch ductile iron pipe. Common laterals for multifamily units shall be designed to have adequate conveyance capacity.

ii. Wye connections shall be the same material as the sewer main. Saddles shall be used only for connection to an existing main.

iii. Bends in house connection lines shall be made using standard fittings. A riser with a cleanout shall be provided in the lateral between the edge of the pavement and property line or within a designated easement as determined by the municipality.

iv. Inspection cleanouts or observation tees within the easement or right-of-way shall be fitted with either a metallic cap or a nonmetal cap fitted with a metallic plug that is suitable for locating the cleanout. Caps shall have a depressed or inverted nut. The inspection cleanout or observation tee shall be placed between the curb or edge of pavement and property line or within a designated easement.

v. Connections beyond the cleanout are under the jurisdiction of the Plumbing Subcode of the Uniform Construction Code (N.J.A.C. 5:23-3.15) through the Plumbing Subcode official. The pipe size and specifications shall comply with the regulations and requirements of the Plumbing Subcode of the Uniform Construction Code.

vi. As-built drawings that include the location of plumbing wyes, as supplied by the contractor, shall be submitted to the municipal engineer.

FIGURE 6.1

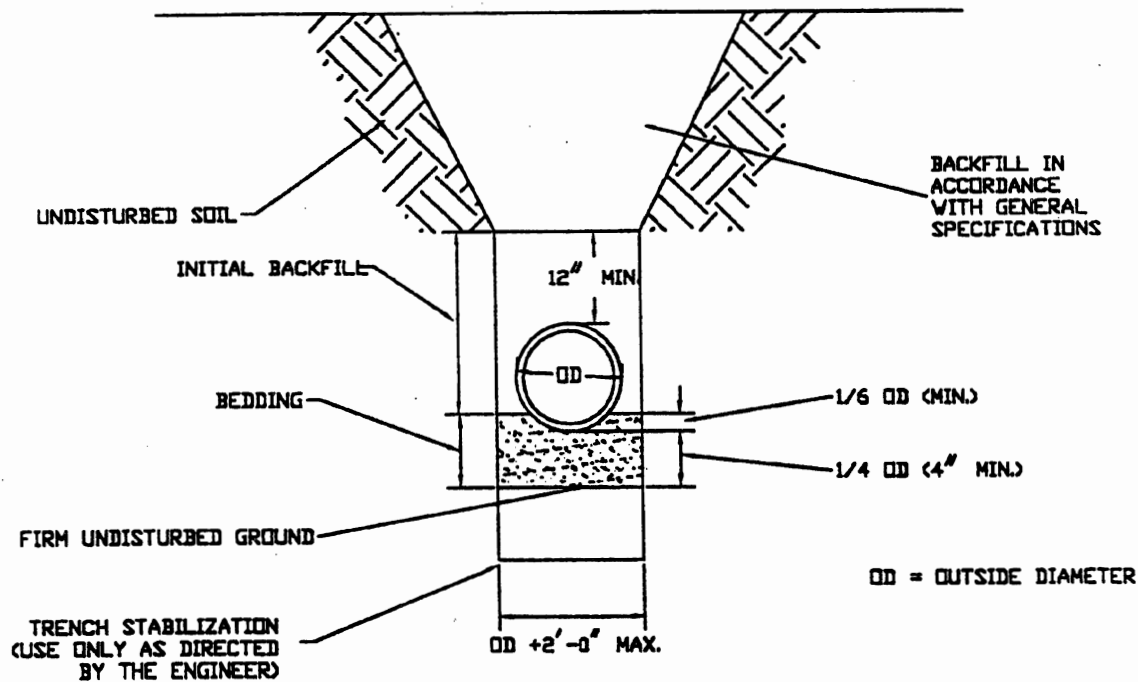

INITIAL BACKFILL AND BEDDING MATERIAL SHALL BE SOIL AGGREGATE DESIGNATION I-8 CONFORMING TO THE REQUIREMENTS OF ARTICLE 901.09 TABLE 901-2 OF THE STANDARD SPECIFICATIONS, REFERENCED EDITION, OR STONE CRUSHINGS TO CONFORM WITH A.A.S.H.T.O. DESIGNATION M43-88 (A.S.T.M. DESIGNATION D448), SIZE NO. 8, 1/8" TO 3/8" (2.36 mm TO 9.25 mm) CLEAN, FREE FLOWING AND SHALL MEET ALL A.S.T.M. C33 SPECIFICATIONS FOR QUALITY AND SOUNDNESS. THE MATERIAL SHALL BE COMPACTED TO 95% MAXIMUM DRY DENSITY IN ACCORDANCE WITH A.S.T.M. D698.

INSTALL CLASS 52 D.I.P. WHEN DEPTH OF INSTALLATION IS LESS THAN 3' OR EXCEEDS 20'.

SDR - 35 PVC SANITARY SEWER TRENCH DETAIL

NOT TO SCALE

Administrative correction.

See: 29 N.J.R. 1296(a).

Amended by R.1999 d.374, effective November 1, 1999 (operative May 1, 2000).

See: 31 N.J.R. 477(a), 31 N.J.R. 3259(a).

Rewrote the section.

Administrative correction.

See: 32 N.J.R. 684(b).

A = Cross-section area of flow in square feet

R = Hydraulic radius in feet, $R = A/P$ where P is equal to the wetted perimeter, measured in feet and defined as the length of a line of contact between the flowing water and the channel.

S = Slope of energy grade line in feet per foot

The Manning roughness coefficients used by design engineers appear in Table 7.1 in N.J.A.C. 5:21-7.2.

SUBCHAPTER 7. STORMWATER MANAGEMENT

5:21-7.1 Stormwater management: general system strategy

(a) Stormwater management systems prepared by design engineers shall emphasize a natural, as opposed to an engineered, drainage strategy.

(b) The applicability of a natural approach depends on such factors as site storage capacity, open channel hydraulic capacity, and maintenance needs and resources. N.J.A.C. 5:21-7.6(c)4 references authoritative sources on natural and nonstructural approaches. Applicability of a stormwater approach also can be limited by regulatory constraints that govern certain structures (for example, dams) or areas (for example, development in a floodplain or wetland). (See N.J.A.C. 5:21-7.5(c).)

(c) Where a municipal ordinance requires the control of runoff from a site that is the subject of a site plan or subdivision application, then the runoff shall be estimated in accordance with provisions of this subchapter. Any structures designed to control volume or rate of flow shall be designed and constructed in accordance with these provisions. Where this subchapter does not include provisions for a particular technique or method, then the design and construction shall be in accordance with best management practices listed in N.J.A.C. 5:21-7.6(b)4.

1. All stormwater collection and conveyance structures shall be designed in accordance with the provisions of this subchapter.

(d) Construction practices shall conform to Standards for Soil Erosion and Sediment Control in New Jersey, N.J.A.C. 2:90, as administered by the New Jersey Department of Agriculture.

(e) Design engineers shall determine hydraulic capacity for open-channel or closed-conduit flow based on the Manning equation, or charts/monographs based on this equation. The hydraulic capacity is termed Q and expressed as discharge in cubic feet per second as follows:

$$Q = (1.486/n) AR^{2/3}S^{1/2}$$

where

n = Mannings roughness coefficient

1. A direct application of Manning's equation may be used for piped storm sewer systems. As an option, design engineers can use a standard step backwater calculation for storm sewer systems if the use of this approach is deemed appropriate by the designer. For other than pipe storm sewer systems, design engineers shall apply Manning's equation only when there is uniform flow, as defined by the following conditions: the bottom slope of the channel, energy grade line, and water surface (hydraulic grade line) are parallel; where the flow regime is in the turbulent range of Reynolds number; and where the boundaries of the cross section of the channel do not move.

(f) Velocities in open channels, excluding water quality swales, at design flow shall not be less than 0.5 of a foot per second and not greater than a velocity that will begin to cause erosion or scouring of the channel. Design engineers shall determine permissible velocities for swales, open channels, and ditches using methods presented in Standards for Soil Erosion and Sediment Control in New Jersey, N.J.A.C. 2:90, New Jersey State Soil Conservation Committee, Division of Rural Resources, New Jersey Department of Agriculture, revised to date.

(g) Velocities in closed conduits at design flow shall be at least two feet per second but not more than the velocity that will cause erosion damage to the conduit, as per the manufacturer's specifications. Minimum allowable pipe slopes shall produce velocity of at least three feet per second when the flow depth is full or half of the pipe diameter.

(h) Design engineers shall base culvert capacity on inlet/outlet analysis, as specified in *Hydraulic Design of Highway Culverts*, Hydraulic Design Series (HDS) No. 5, Report No. FHWA-IP-85-15, U.S. Department of Transportation, Federal Highway Administration, September 1985, incorporated here in by reference.

Amended by R.1999 d.374, effective November 1, 1999 (operative May 1, 2000).

See: 31 N.J.R. 477(a), 31 N.J.R. 3259(a).

Inserted a new (c); recodified former (c) through (g) as (d) through (h); in the new (e)1, inserted "there is a uniform flow, as defined by the following conditions:" following "only when" in the last sentence; and in the new (g), substituted a reference to three feet per second for a reference to two feet per second.

Administrative correction.

See: 32 N.J.R. 684(b).

5:21-7.2 Runoff estimation techniques

(a) Watershed stormwater management requires the determination of a watershed runoff hydrograph that displays and compares the peak discharge rate and volume. Both parameters shall compare pre- and post-development conditions. The design engineer shall determine the status of the drainage area. All significant land features such as ponds, depressions, or hedgerows that increase ponding factors shall be considered by the design engineer to compute pre-development runoff. If the design engineer is able to verify that a given hydrologic condition has existed on the site for a period of at least five years prior to the time of computation, then this existing condition may be used by the design engineer to determine runoff coefficients. As an alternative, however, the design engineer should assume the drainage area in the pre-development condition to be in good hydrologic condition (if the lands are pastures, lawns, or parks), to have good cover (if the lands are woods), or to have had conservation treatment (if the lands are cultivated).

(b) Design engineers shall use the runoff hydrograph peak rate to determine the configuration and sizes of pipes, channels, and other routing or flow-control structures. They also shall use runoff volume calculations generated by the hydrograph to determine the size of detention and retention facilities.

(c) For the runoff peak rate of discharge calculation, design engineers shall have the option to choose the methodology to estimate peak rate of discharge. For relatively small drainage areas of up to one-half square mile (320 acres), the peak rate of runoff may be calculated by the Rational Method, its derivatives, or the referenced methods that follow.

1. For areas greater than 320 acres, design engineers shall calculate peak rate of runoff in accordance with the following procedures and methods, incorporated herein by reference.

i. *Urban Hydrology for Small Watersheds, Technical Release No. 55 (TR-55)*, U.S. Department of Agriculture, Soil Conservation Service, Engineering Division, as supplemented or amended to date;

ii. *Computer Program for Project Formulation—Hydrology, Technical Release No. 20 (TR-20)*, U.S. Department of Agriculture, Soil Conservation Service, Engineering Division, as supplemented or amended to date; or

iii. *The New HEC-1 Flood Hydrograph Package, Technical Paper No. 82*, Hydraulic Engineering Center, U.S. Army Corps of Engineers, used in appropriate conditions with appropriate values.

2. The equation for the Rational Method is:

$$Q_p = C I A$$

where

Q_p = the peak runoff rate in cubic feet per second

C = the runoff coefficient

I = the average rainfall intensity in inches per hour occurring at the time of concentration t_c

t_c = time of concentration in minutes

A = the size of the drainage area in acres

i. Typical C values for 100 year frequency storm events appear in Table 7.2 below. Coefficients for recurrence intervals more frequent than the 100-year storm should be reduced in accordance with Table 7.3 below. Impervious surfaces are not subject to adjustment.

ii. The Rational Method is most accurate when dealing with uniform drainage areas. Design engineers may divide nonuniform drainage areas into "uniform" sub-drainage areas and calculate the runoff from each of these areas separately, or they may use the weighted average technique for a composite drainage area. Design engineers also may use runoff coefficients from the following sources, incorporated herein by reference:

(1) *Design of Roadside Drainage Channels—Hydraulic Design Series No. 4, Report No. FHWA-EPD-86-103*, May 1965, U.S. Department of Transportation, Federal Highway Administration, as supplemented or amended to date; and

(2) *Airport Drainage, AC¹⁵⁰/5320-5B*, U.S. Department of Transportation, Federal Aviation Administration, July 1970, as supplemented or amended to date.

3. Design engineers may estimate time of concentration (t_c) with Figure 7.1, Time of Concentration nomograph from *Design Manual—Roadway*, New Jersey Department of Transportation, Division of Roadway Design, Bureau of Roadway Design Standards, May 1992, below. Use of this figure is limited to the design of storm sewer systems. For other purposes, design engineers shall use the procedures outlined in Chapter 3 of *Technical Release No. 55, Urban Hydrology for Small Watersheds (TR-55)*, U.S. Department of Agriculture, Soil Conservation Service, Engineering Division, as supplemented or amended to date.

Hydrologic Soil Group

iii. Twenty-five-year storm for culvert design where the culvert will be located in streams shown as a blue line on the New Jersey State Atlas or the United States Coast and Geodetic Survey maps. Culverts with an upstream drainage area of 50 acres or more shall be designed to accommodate a 100-year frequency storm in accordance with Flood Hazard Area Control Regulations, N.J.A.C. 7:13-2.16.

iv. Twenty-five-year storms for open channels where the upstream drainage area is less than 50 acres. When the upstream drainage area is 50 acres or more, design engineers shall design open channels to accommodate the 100-year storm, in accordance with Flood Hazard Area Control Regulations, N.J.A.C. 7:13-2.16.

5. The size of the drainage area shall include onsite and offsite lands contributing to the design point.

6. Computer software adaptations of the Rational Method or the S.C.S. TR-55 are acceptable, provided their data and graphic printout allow review and evaluation.

(d) Design engineers shall use a consistent method to calculate peak rate of runoff and volume when computing runoff hydrographs. If either TR-55, TR-20, or HEC-1 is used to calculate peak rate of runoff, then the same method shall be used to determine volume. If the rational method is used for peak flow calculations, the design engineer shall use the Modified Rational method to calculate peak volume to be used for basin routing. A maximum drainage area of 20 acres shall be used for the Modified Rational Method.

Administrative correction.
 See: 29 N.J.R. 1296(a).
 Amended by R.1999 d.374, effective November 1, 1999 (operative May 1, 2000).
 See: 31 N.J.R. 477(a), 31 N.J.R. 3259(a).
 In (b), substituted "size" for "necessity for, and sizing" in the second sentence; in (c), added a third sentence in 2i, and inserted new third and fourth sentences in the introductory paragraph of 4; in (d), inserted "when computing runoff hydrographs" at the end of the first sentence; and in Table 7.1, added a reference to Minor Streams.
 Administrative correction.
 See: 32 N.J.R. 684(b).

5:21-7.3 Runoff collection system design

(a) Design engineers shall determine pipe size based on design runoff, conduit entrance conditions, and hydraulic capacity.

(b) In general, no pipe size in the storm drainage system shall be less than 15 inches in diameter. Design engineers may use a 12-inch diameter pipe as a cross-drain to a single inlet. Design engineers shall use the Manning equation to determine hydraulic capacity of pipes.

(c) All discharge pipes shall terminate with an appropriate precast concrete or flared-end section or concrete head-wall with or without wingwalls, as conditions require. De-

sign engineers shall consider such site conditions as slope, soil stability, vegetation, grade, and size of conduit to determine whether or not to use wingwalls.

(d) Materials used in the construction of storm sewers shall be constructed of reinforced concrete, ductile iron, or corrugated polyethylene, or, when approved by the municipal engineer, corrugated metal. The most cost-effective materials shall be permitted that conform to local site conditions and reflect the relevant operations, maintenance, and system character of the municipal stormwater system. Specifications referred to, such as ASTM or AWWA, shall be the latest revision in effect at the time of application.

1. The following apply to reinforced concrete pipe:
 - i. Circular reinforced concrete pipe and fittings shall meet the requirements of ASTM C76.
 - ii. Elliptical reinforced concrete pipe shall meet the requirements of ASTM C507.
 - iii. Joint design and joint material for circular pipe shall conform to ASTM C443.
 - iv. Joints for elliptical pipe shall be bell and spigot or tongue and groove sealed with butyl, rubber tape, rubber ring gaskets, or external sealing bands conforming to ASTM C877.
 - v. All pipe shall be Class III, minimum unless loading conditions call for stronger pipe (that is, higher class).
 - vi. The minimum depth of cover over the concrete pipe shall be as designated by the American Concrete Pipe Association in Table 7.4 below as follows.

TABLE 7.4
 MINIMUM DEPTH OF COVERAGE OVER
 CONCRETE PIPE

Pipe Diameter (in inches)	ASTM Class Pipe	Minimum Cover (surface to top of pipe in inches)
12	III	17
	IV	12
	V	7
15	III	16
	IV	11
	V	7
18	III	16
	IV	10
	V	6
24	III	15
	IV	6
	V	6
	III	10

Pipe Diameter (in inches)	ASTM Class Pipe	Minimum Cover (surface to top of pipe in inches)
30	IV V	6 6
36 & above	III IV	6 6

Minimum depth of coverage as designated by the American Concrete Pipe Association.

vii. Minimum depth of cover standards for ductile iron and corrugated polyethylene pipe shall conform to manufacturer standards.

2. Ductile iron pipe shall conform to ANSI/AWWA C151/A21.51. Joints shall conform to ANSI/AWWA C111/A21.11 or ANSI/AWWA C115/A21.15 as appropriate. Pipe shall be designed in accordance with ANSI/AWWA C150/A21.50. The outside of the pipe shall be coated in accordance with ANSI/AWWA C151/A21.51, and the inside lined in accordance with ANSI/AWWA C104/A21.4. Ductile iron pipe shall be installed in accordance with AWWA C600.

3. Corrugated polyethylene pipe shall conform to AASHTO M252 for three through 10 inches and AASHTO M294 for sizes 12 inches and larger. All pipes greater than 12 inches in diameter shall be Type S, unless conditions dictate otherwise. Materials shall conform to ASTM D3350, "Standard Specification for Polyethylene Plastics Pipe and Fittings Materials." Pipe joints and fittings shall be compatible with the pipe material and shall conform to the same standards and specifications as the pipe material. Pipe couplers shall not cover less than one full corrugation on each section of pipe. Installation shall be in accordance with ASTM D2321, "Practice for Underground Installation of Thermoplastic Pipe for Sewers and Other Gravity-Flow Applications." Backfill material shall be placed in six-inch lifts and compacted to 95 percent minimum dry density, per AASHTO T99. In areas of high groundwater tables, design engineers shall check for floatation.

4. Corrugated metal pipe, when approved by the municipal engineer, shall meet the requirements and be installed in the manner specified in the subchapter appendix.

(e) Pipe bedding and backfill shall be provided as specified in *Design and Construction of Urban Stormwater Management Systems*, ASCE Manuals and Reports of Engineering Practice No. 77, 1993, incorporated herein by reference. Bedding and backfill for any pipe material not covered by this manual shall be installed in accordance with manufacturer's recommendations. The municipal engineer may require the developer to provide professional certification as to the suitability of backfill material and where such suitability does not exist, any modifications needed to use on-site material and the appropriate methods to install this material. The municipal and/or utility engineer shall rely on this certification.

(f) Maintenance easements shall be provided around stormwater facilities located outside of the public right-of-way. The size of the easement shall be dictated by working needs.

Amended by R.1999 d.374, effective November 1, 1999 (operative May 1, 2000).

See: 31 N.J.R. 477(a), 31 N.J.R. 3259(a).

In (d), inserted a reference to Table 7.4 in 1vi, rewrote 2, and rewrote the first sentence in 3.

5:21-7.4 Inlets, catch basins, manholes and outlets

(a) Design engineers shall design inlets, catch basins, and manholes in accordance with the New Jersey Department of Transportation's *Standard Specifications for Road and Bridge Construction* (1989). Design engineers shall use bicycle-safe grates. For Type A inlets, they should use a frame and single grate. Type B inlets require a frame, grate, and curb-type inlet with back piece. Type E inlets require a frame and double grate.

(b) Inlet spacing depends on the inlet capacity. Maximum distance between inlets is 400 feet. The maximum capacity of a curb inlet shall be six cubic feet per second. Area inlets in parking lots should be limited to three cubic feet per second.

(c) Manholes shall be precast concrete or concrete block coated with two coats of portland cement mortar outside the manhole. Masonry brick may be used to make vertical adjustment to rims, as long as the adjustments are 12 inches or less. In acidic soils, all manholes shall have two coats of black bitumastic waterproofing applied per manufacturer's instruction.

(d) If precast manhole barrels and cones are used, they shall conform to ASTM Specification C478, with round rubber gasketed joints, conforming to ASTM Specification C923. Both ASTM Specifications are incorporated herein by reference. Maximum absorption shall be eight percent in accordance with ASTM Specification C478, method A.

(e) If precast manholes are used, the top riser section shall terminate less than one foot below the finished grade, and the manhole cover shall be flush with the finished grade.

(f) Manhole frames and covers shall be of cast iron, conforming to ASTM Specification A48, Class 30, incorporated herein by reference, and be suitable for H-20 loading capacity. Manhole covers in remote locations may have a locking device.

(g) Outlet grates, fences, and other safety features for stormwater management facilities shall conform with New Jersey Department of Environmental Protection's Stormwater Management Rules, N.J.A.C. 7:8. Safety requirements for detention basin and other stormwater facilities are incorporated in N.J.A.C. 5:21-7.5(f)6.

(h) The channel should be, insofar as possible, a smooth continuation of the pipe. The pipe may be laid through the manhole and the top half removed by saw cut. The completed channel should be U-shaped. The channel height shall be three-fourths of the diameter of the pipe.

(i) The bench should provide good footing for a workman and a place where minor tools and equipment can be laid. It must have a slope of four to eight percent.

Administrative correction.

See: 29 N.J.R. 1296(a).

Amended by R.1999 d.374, effective November 1, 1999 (operative May 1, 2000).

See: 31 N.J.R. 477(a), 31 N.J.R. 3259(a).

5:21-7.5 Detention basins and other stormwater facilities

(a) Development shall use the best available technology to accommodate stormwater management by natural drainage strategies where possible and practicable. Detention facilities, when required or selected, shall be designed, constructed, and maintained according to the following standards.

(b) Design engineers shall coordinate structural detention requirements with nonstructural practices, such as cluster land-use development, open space acquisition, riparian buffers, and flood hazard controls.

(c) Detention and all other stormwater facilities shall conform to the New Jersey Department of Environmental Protection's Stormwater Management Rules, at N.J.A.C. 7:8-3.4. Design engineers shall also adhere to, when applicable, the stormwater design requirements in the following rules:

1. Coastal Zone Management Rules, N.J.A.C. 7:7E;
2. Dam Safety Standards, N.J.A.C. 7:20;
3. Soil Erosion and Sediment Control Standards, N.J.A.C. 2:90-1;
4. Flood Hazard Area Regulations, N.J.A.C. 7:13;
5. Pinelands Regulations, N.J.A.C. 7:50-6.81 through 6.88; and
6. Freshwater Wetlands Protection Act Rules, N.J.A.C. 7:7A.

(d) Where municipalities require the use of detention facilities, design engineers shall design the basins to accommodate site runoff generated from two-year, 10-year, and 100-year storms as routed to the basin, considered individually, unless the detention basin is classified as a dam, in which case the facility must comply with the Dam Safety Standards, N.J.A.C. 7:20.

1. These design storms shall be defined as either a 24-hour storm using Type III rainfall distribution when using U.S. Soil Conservation Service procedures (such as TR-20 or TR-55 tabular method), or the design storm

resulting in the greatest storage volume to achieve the required outflow using a design method such as the Modified Rational Method. Runoff greater than that occurring from the 100-year, 24-hour storm will be passed over an emergency spillway.

i. A map of approximate geographic boundaries for S.C.S. rainfall distributions presented on page B-2 of the June 1986 edition of TR-55 shows all of New Jersey in the Type III region. Although the May 1982 version of TR-20 does not include a standard S.C.S. 24-hour, cumulative Type III distribution rainfall table like it does for Type I, IA, and II, there is a test version (Version 2.04TEST) of the program available from the S.C.S. which does. The Type III distribution also can be manually added to a TR-20 model by using a RAINFL table.

2. Detention facilities shall be designed to accommodate runoff from the development of the site for the two-, 10-, and 100-year storm events so that pre-development peak flow rates that impact on downstream properties, watercourses, and/or drainage systems are not increased.

3. Where there is not a regional stormwater plan, as specified below in (d)4, then the design engineer shall design detention facilities such that the post-project construction peak runoff for the two-year storm event is 50 percent of the pre-project construction peak runoff rate. The post-project construction peak runoff rates for the 10 and 100-year storm events shall be 75 and 80 percent, respectively, of the pre-project construction peak runoff rates. It should be noted that these percentages only apply to the portion of the post-project runoff from the site under development. Offsite runoff may be computed at 100 percent of the pre-project rate.

4. If a watershed stormwater management plan for the region or watershed exists, approved and adopted pursuant to the New Jersey Department of Environmental Protection rules at N.J.A.C. 7:8, then the design engineer shall design stormwater management systems to conform to that plan. For some parts of the watershed, this may mean a detention basin is unnecessary.

5. If the development site is not part of a watershed stormwater management plan, then the design engineer may model the watershed to be consistent with regulations administered by the Department of Environmental Protection and shall design stormwater management facilities to conform to that model. This analysis shall include impacts of existing development and all potential future development in the drainage area. For some parts of the watershed, this may mean detention is unnecessary.

(e) Design engineers shall locate detention facilities (either "wet" or "dry") so as to not interfere with or adversely affect existing surface waters on the site or adjacent to the site. Excavation for detention facilities shall be designed to be the maximum practical distance above seasonally high groundwater elevation. In the case of "wet" detention facili-

ties, storage may only be presumed to be available above the elevation of the seasonal high groundwater. If the facility is designed as an infiltration basin, the bottom of the basin shall be a minimum of two feet above the elevation of the seasonally high water table. The determination of the seasonal high water table shall be made by the applicant's engineer.

(f) The following list of general structural criteria shall be used to design stormwater detention basins.

1. Detention components: principal basin control structure (quantity control), as follows:

i. Principal basin control structures will consist of orifice and/or weir control devices. Design engineers shall design orifices based upon the following equation:

$$Q = C A (2gH)^{0.5}$$

where

Q = the flow rate in cubic feet per second

C = 0.6 (The orifice flow coefficient "C" may vary, depending on entrance conditions. Design engineers may use other coefficients with appropriate references.)

A = cross-section area of flow in square feet

H = the vertical distance in feet between the center of the orifice and the water surface

2g = 64.4 feet per second²

To minimize the chance of clogging, orifices intended solely for runoff quantity control will be at least six inches in diameter (or its equivalent). All joints are to be watertight. In addition, trash racks and/or anti-vortex devices shall be required. When weirs are used alone or in conjunction with orifices, design engineers shall use the following equation:

$$Q = C_w L(h)^{3/2}$$

where

Q = the flow rate in cubic feet per second

C_w = 3.2 (design engineers may use other coefficients with appropriate references)

L = length of the weir in feet

h = the vertical distance in feet between water surface elevation and the crest of the weir.

All weirs shall be constructed as part of a reinforced concrete structure with appropriate grates.

ii. Eight-inch-thick, anti-seep collars are to be installed along outlet pipes. Reinforcement steel shall be No. 5 bars at 12 inches both ways, with two inches of cover on both faces (minimum).

iii. Where necessary for stability of the outlet pipe, a concrete cradle shall be provided.

iv. All principal basin control structures shall be precast or reinforced concrete. All joints are to be watertight.

v. Suitable lining shall be placed upstream and downstream of principal basin control structures, as necessary, to prevent scour and erosion. Such lining shall conform to Standards for Soil Erosion and Sediment Control in New Jersey, N.J.A.C. 2:90, promulgated by the N.J. State Soil Conservation Committee.

2. Detention components: emergency spillways, as follows:

i. Vegetated emergency spillways shall have side slopes not exceeding three horizontal to one vertical.

ii. Maximum velocities in emergency spillways shall be checked based on the velocity of the peak flow in the spillway resulting from the routed Emergency Spillway Hydrograph. The design of the emergency spillway will be based on the 100-year inflow to the basin, except for class IV dams, which shall comply with the Dam Safety Standards, N.J.A.C. 7:20 The design of the emergency spillway assumes the principal spillway is malfunctioning and will not allow any discharge or flow. Where maximum velocities exceed those contained in Table 7.5 below, suitable lining shall be provided.

iii. Where maximum velocities exceed the allowable velocities for soil stability as determined in the Standards for Soil Erosion and Sediment Control in New Jersey, N.J.A.C. 2:90, promulgated by the N.J. State Soil Conservation Committee, suitable lining should be provided. Design engineers also may check maximum velocities in emergency spillways based on the velocity of the peak flow in the spillway resulting from the routed Emergency Spillway Hydrograph. Where maximum velocities exceed those contained in Table 7.5 below, suitable lining shall be provided. Linings shall meet specifications required in Hydraulic Engineering Circular No. 15—Design of Stable Channels with Flexible Linings, published by the U.S. Department of Transportation, Federal Highway Administration or Standards for Soil Erosion and Sediment Control in New Jersey, N.J.A.C. 2:90, promulgated by the State Soil Conservation Committee, New Jersey Department of Agriculture.

TABLE 7.5

PERMISSIBLE VELOCITIES FOR EMERGENCY SPILLWAYS WITH UNIFORM STANDS FOR VARIOUS WELL-MAINTAINED GRASS COVERS

Ground Cover	Slope Percent	Permissible Velocities On:	
		Erosion-resistant soils (fps)	Easily eroded soils (fps)
Kentucky bluegrass	5-10	6	4
Lawn grass mixture	0-5	5	4
	5-10	4	3
Weeping lovegrass			
Alfalfa	0-5	3.5	2.5
Crabgrass			

Note: fps=feet per second

Designs are not limited to the ground covers shown above. Design engineers may use reinforced grass technologies and other types of ground cover in accordance with appropriate authoritative standards. Source: Soil Conservation Service, U.S. Department of Agriculture (Washington, DC: Government Printing Office, 1959). Cited in ULI-ASCE-NAHB, Residential Storm Water Management: Objectives, Principles, and Design Considerations (Washington, DC: Government Printing Office, 1975).

3. Detention components: dams, as follows:

i. Dam refers to any artificial dike, levee, or other barrier with appurtenant works that is constructed to impound water on a permanent or temporary basis and raises the water level five feet or more above the usual, mean, low-water height when measured from the downstream toe-of-dam to the emergency spillway crest, or, in the absence of an emergency spillway, the top of the dam.

ii. Design engineers shall design all dams in accordance with Dam Safety Standards, N.J.A.C. 7:20, administered by the New Jersey Department of Environmental Protection.

4. Detention basin berms and embankment ponds, as follows:

i. A detention basin berm is a water impoundment made by either constructing an embankment (a facility referred to as an embankment pond), or excavating a pit or dugout that does not qualify as a dam. Detention basin berms constructed by the second method are referred to as excavated ponds.

ii. Site conditions shall be such that runoff from the design storm can safely pass through: a natural or constructed emergency spillway designed to accept the entire 100-year flow; a combination of a principal spillway and the emergency spillway designed to ensure passage of the 100-year flow when either the principal spillway and/or the emergency spillway flows are impeded by debris; or a principal spillway designed so as to allow it to continue to function reliably, passing the 100-year flow, when impeded by debris.

(1) Drainage area of the pond shall be protected against erosion so that expected sediment does not shorten the planned effectiveness of the structure.

(2) When necessary, embankment ponds shall have foundation cutoff walls of relatively impervious material under the berm. The cutoff walls shall extend up to abutments as required and be deep enough to extend into a relatively impervious layer, or provide for a stable structure when combined with seepage control. The cutoff trench shall have a bottom width adequate to accommodate the equipment used for excavation, backfill, and compaction operations. Cutoff wall side slopes shall not be steeper than one horizontal to one vertical. The cutoff walls shall extend up to the normal water line and the minimum depth shall be at least three feet.

(3) Design engineers shall include seepage controls if pervious layers are not intercepted by the cutoff, seepage creates swamping downstream, such control is needed to insure a stable embankment, or special problems may require drainage for a stable berm. Seepage may be controlled by foundation, abutment, or embankment drains; reservoir blanketting; or a combination of these measures.

(4) The minimum top width for a berm shall be six feet. The minimum top width of dams should be 10 feet.

(5) All slopes must be designed to be stable. If needed to protect the slopes of the berm, special measures such as rock rip-rap, sand gravel, fabrics, geofabrics, geomembranes, or special vegetation shall be provided, as specified by the standards in: Guide for Design and Layout of Vegetative Wave Protection for Earth Dam Embankments, Technical Release No. 56, and Riprap for Slope Protection Against Wave Action, Technical Release No. 69. Both reports are published by the U.S. Department of Agriculture, Soil Conservation Service, and are incorporated herein by reference.

(6) The minimum elevation of the top of the settled embankment shall be one foot above the water surface in the detention basin, with the emergency spillway flowing at the design depth. The minimum difference in elevation between the crest of the emergency spillway and the settled top width of the structure shall be two feet for all berms having more than a 20-acre drainage area or more than 20 feet in effective height. Design engineers shall increase the design height of the structure by the amount needed to insure that after settlement the height of the berms equals or exceeds the design height. This increase shall not be less than five percent, except where detailed soil testing and laboratory analysis shows that a lesser amount is adequate.

(7) Design engineers shall place a pipe conduit with needed appurtenances under or through the berm except where rock, concrete, or other types of mechanical spillways are used or where the rate and duration of flow can be safely handled by a vegetated or earth spillway.

iii. The design elevation of the top of all embankments and berms shall be one foot or greater than the maximum water surface elevation in the basin, when stormwater from the 100-year flood passes over the emergency spillway. The design height, defined as the vertical distance from the top to the bottom of the deepest cut, shall be constructed to insure that the top elevation will be maintained following all settlement.

(1) When the design discharge of the principal spillway is considered in calculating peak outflow

through the emergency spillway, the crest elevation of the inlet shall be such that the full flow will be generated in the conduit before there is discharge through the emergency spillway. The inlets and outlets of the principal spillway shall be designed to function satisfactorily for the full range of flow and hydraulic head anticipated. The capacity of the pipe conduit shall be adequate to discharge long-duration, continuous, or frequent flows without flow through the emergency spillways. The pipe diameter shall be no less than six inches. If the pipe conduit diameter is larger than 10 inches, its design discharge may be considered when calculating the peak outflow rate through the emergency spillway.

(2) Pipe conduits under or through the berm shall be capable of withstanding external loading without yielding, buckling, or cracking. Flexible pipe strength shall not be less than that necessary to support the design load with the maximum of five percent deflection. The inlets and outlets shall be structurally sound and made of materials compatible with those of pipe. All pipe joints shall be made watertight by the use of couplings, gaskets, or caulking.

iv. In earthen berms and embankment ponds, acceptable pipe materials are corrugated polyethylene, reinforced concrete, polyvinyl chloride, and ductile iron. When necessary for stability, concrete and ductile pipe shall be laid in a concrete bedding. Corrugated polyethylene pipe exposed to direct sunlight shall be made of ultraviolet-resistant materials and protected by coating or shielding, or provisions for replacement should be made as necessary. Connections of corrugated polyethylene pipe to less flexible pipe or structure must be designed to avoid stress concentrations that could rupture the plastic. Design engineers shall follow specifications in Table 7.6 below for polyvinyl chloride (PVC) pipe. Design engineers shall provide for seepage control if the conduit is of smooth pipe larger than eight inches in diameter.

TABLE 7.6

ACCEPTABLE PVC PIPE FOR USE IN EARTH BERMS[†]

Normal pipe size (inches)	Schedule for standard dimension ratio(SDR)	Maximum depth of fill over pipe (feet)
4 or smaller	schedule 40	15
	schedule 80	20
	SDR 26	10
6, 8, 10, 12	schedule 40	10
	schedule 80	15
	SDR 26	10

[†] Polyvinyl chloride pipe, PVC 1120 or PVC 1220, conforming to ASTM D1785 or ASTM D2241.

Design engineers shall provide for seepage control if the conduit is of smooth pipe larger than eight inches in diameter.

v. Seepage control along pipes extending through embankments shall be controlled by use of a filter and drainage diaphragm, unless it is determined that anti-seep collars will adequately serve the purpose.

(1) The drain is to consist of sand meeting fine concrete aggregate requirements (at least 15 percent passing through the No. 40 sieve, but no more than 10 percent passing through the No. 100 sieve). If unusual soil conditions exist, design engineers shall make a special design analysis. The drain shall be a minimum of two-feet thick and extend vertically upward and horizontally at least three times the pipe diameter, and vertically downward at least 18 inches beneath the conduit invert. The drain diaphragm shall be located approximately parallel to the centerline of the embankment. The drain shall be outletted at the embankment downstream toe, preferably using a drain backfill envelope continuously along the pipe where it exits in the embankment. Protecting drain fill from the surface erosion will be necessary.

(2) When antiseep collars are used in lieu of a drainage diaphragm, they shall have watertight connection to the pipe. Maximum spacing shall be approximately 14 times the minimum projection of the collar measured perpendicular to the pipe. Collar material shall be compatible with the pipe materials. The antiseep collar(s) shall increase by 15 percent the seepage path along the pipe. When antiseep collars are used in lieu of the drainage diaphragm, the design engineers shall use the following criteria to determine the size and number of antiseep collars.

- Let V = vertical projection and minimum horizontal projection of the antiseep collar in feet.
 - Let L = length in feet of the conduit within the zone of saturation, measured from the downstream side of the riser to the toe drain or point where the phreatic line intercepts the conduit, whichever is shorter.
 - Let n = number of antiseep collars.
- The ratio of the length of the seepage (L+2nV) is to be at least 1.15. Antiseep collars should be equally spaced along part of the barrel within the saturated zone at distances of not more than 25 feet.

vi. Closed circuit spillways designed for pressure flow must have adequate antivortex devices. To prevent clogging of the conduit, an appropriate trash guard shall be installed at the inlet or riser.

vii. Emergency spillways convey the design flow safely past earth embankments when the principal or auxiliary spillway is disabled. Design engineers shall provide for an emergency spillway for each basin.

(1) Emergency spillways shall provide for passage of the design flow at a safe velocity to a point downstream where the berm will not be endangered. The maximum permissible velocity in the exit channel shall be four feet per second, where only sparse vegetative cover can be expected; where excellent vegetative cover and a vigorous sod can be expected and maintained, the maximum permissible velocity is 6 feet per second.

(2) If chutes or drops are used for the principal or emergency spillways, they shall be designed according to standards in the U.S. Department of Agriculture, Soil Conservation Service's *Engineering Manual for Conservation Practices* (1984), or the U.S. Department of Agriculture's *National Engineering Handbook*, section 5, "Hydraulics;" section 11, "Drop Spillways;" and section 14, "Chute Spillways," incorporated herein by reference. The minimum capacity of a structural spillway shall be that required to pass the peak flow expected from the design storm.

viii. For excavated basins, provisions shall be made where needed for a principal spillway, emergency spillway, and embankment in accordance with the embankment and berm criteria described in this section.

(1) Where soil conditions and safe maintenance practices allow, side slopes of the excavated basin shall be stable and no steeper than three horizontal to one vertical.

ix. The material placed in the fill shall be free of detrimental amounts of sod, roots, frozen soil, stones more than six inches in diameter (except rock fills), and other objectionable material.

(1) Drainfill shall be kept from being contaminated by adjacent soil materials during placement by either placing it in a cleanly excavated trench, or by keeping the drain at least one foot above the adjacent earthfill.

(2) Selected drainfill and backfill material shall be placed around structures, pipe conduits, and antiseep collars at about the same rate on all sides to prevent damage from unequal loading. Fill material shall be placed and spread beginning at the lowest point in the foundation and then bringing it up in continuous horizontal layers thick enough that the required compaction can be obtained. The fill shall be constructed in continuous horizontal. If openings or sectionalized fills are required, the slope of the bonding surfaces between the embankment in place and the embankment to be placed shall not be steeper than the ratio of three horizontal to one vertical. The bonding surface shall be treated the same as that specified for the foundation to insure a good bond with the new fill.

(3) The distribution and gradation of materials shall be such that no lenses, pockets, streaks, or

layers of material shall differ substantially in texture or gradation from the surrounding material. If it is necessary to use materials of varying texture and gradation, the more impervious material shall be placed in the center and upstream parts of the fill. If zoned fills of substantially differing materials are specified, the zones shall be placed according to lines and grades shown on the drawings. The complete work shall conform to the lines, grades, and elevations shown in the drawings or as staked in the field.

(4) The moisture content of the fill material shall be adequate for obtaining the required compaction. Material that is too wet shall be dried to meet this requirement, and material that is too dry shall be wetted and mixed until the requirement is met. Construction equipment shall be operated over each layer of fill to insure that the required compaction is obtained. Special equipment shall be used if needed to obtain the required compaction. If a minimum required density is specified, each layer of fill shall be compacted as necessary to obtain that density.

(5) Fill adjacent to structures, pipe conduits, and drainfill or antiseep collars shall be compacted to a density equivalent to that of the surrounding fill by hand tamping or by using manually directed power tampers or plate vibrators. Fill adjacent to concrete structures shall not be compacted until the concrete has had time to gain enough strength to support the load.

x. All permanent and temporary stabilization should be applied pursuant to the Standards for Soil Erosion and Sediment Control in New Jersey, N.J.A.C. 2:90.

xi. In a principal spillway, pipe materials shall conform to the appropriate specifications. Antiseep collars shall be made of materials compatible with that of the pipe and shall be installed according to the manufacturer's instructions. It may be firmly and uniformly bedded throughout its length, and shall be installed to the line and grade shown on the drawings.

xii. The mix design and testing of concrete shall be consistent with the size requirements of the job. Mix requirements or necessary strength shall be specified. The type of cement, air entrainment, slump, aggregate, or other properties shall be specified as necessary. All concrete is to consist of a workable mix that can be placed and finished in an acceptable manner. Necessary curing shall be specified. Reinforcing steel shall be placed as indicated on the plans and shall be held securely in place during concrete placement. Subgrades and forms shall be installed to line and grade, and the forms shall be mortar tight and unyielding as the concrete is placed.

xiii. Foundation and embankment drains, if required, shall be placed to the line and grade shown on the drawings. Detailed requirements for drain material

and any required pipe shall be shown in the drawing and specifications for the job.

xiv. Concerning excavated basins, the compacted excavation shall conform to the lines, grades, and elevations shown on the drawings or as staked in the field.

xv. Concerning embankment and excavated berms, construction operations shall be carried out so that erosion and air and water pollution are minimized, and held within legal limits. All work shall be conducted in a skillful manner. The completed job shall present a workmanlike appearance.

(1) Measures and construction methods that enhance fish and wildlife values shall be incorporated as needed and practical. Ground cover to control erosion shall be established as needed and practical. Fencing shall be provided as needed.

5. Detention facilities in flood hazard areas, as follows:

i. Detention development must comply with all applicable regulations under the Flood Hazard Area Control Act, N.J.S.A. 58:16A-50 et seq.

6. The following safety provisions shall apply to stormwater management basins and parts thereof:

i. Trash racks shall be installed at the intake to the outlet from the stormwater management basin to ensure proper functioning of the basin outlets.

ii. Trash racks shall be designed to have parallel bars with no greater than six-inch spacing. The spacing shall be designed so as not to adversely affect the hydraulic performance of the outlet pipe or structure.

iii. The average velocity of flow through a clean trash rack is not to exceed 2.5 feet per second under the full range of stage and discharge. Velocity is to be computed on the basis of the net area of opening through the rack.

iv. Any outlet structure with an overflow grate must have the grate secured but removable for emergencies and maintenance. Grate spacing shall be no greater than two inches across the smallest dimension.

v. Trash racks and overflow grates shall be constructed and installed to be rigid, durable, and corrosion resistant and shall be designed to withstand a perpendicular live loading of 300 lbs/ft sq.

vi. Every outlet structure of a basin shall have escape provisions in or on the structure. Free-standing outlet structures may be excluded at the discretion of the approving authority.

vii. Safety ledges shall be constructed on the slopes of all new retention basins with a permanent pool of water deeper than two-and-one-half feet. Ledges shall be comprised of two steps, each four to six feet in width, one located approximately two-and-one-half feet below the permanent water surface, and the second located one to one-and-one-half feet above the permanent water surface.

viii. In new stormwater management basins, maximum interior slopes for earthen dams, embankments, or berms shall not exceed three horizontal to one vertical.

ix. Municipalities or other specified agencies may grant a variance or exception from these safety standards if they determine in writing that such variance or exception will not constitute a threat to the public safety.

7. Stormwater management facilities shall be regularly maintained to ensure that they function at design capacity and to prevent health hazards associated with debris buildup and stagnant water.

i. Maintenance and upkeep responsibility depend on the ownership of the facilities. If the drains, basins and/or other features of the stormwater system in the residential development are part of a public drainage system, then the municipality or an appropriate public entity is responsible for maintenance and upkeep. If part or all of the residential stormwater management system is privately owned, then the privately owned portion of the system must be privately maintained, unless the municipality or other appropriate public agency agrees to assume responsibility for the facilities. The terms of the agreement shall be in a form acceptable to the municipal attorney and may include but are not limited to maintenance easements, personal guarantees, deed restrictions, covenants, and bonds.

ii. In cases where there is common ownership of property that is not part of a publicly owned drainage system, a homeowner's association or similar permanent entity may be established as the agent responsible for upkeep, absent an agreement with the municipality or other appropriate public entity.

Administrative correction.

See: 29 N.J.R. 1296(a).

Administrative correction.

See: 29 N.J.R. 2816(a).

Public Notice: Egg Harbor Township special area standards.

See: 30 N.J.R. 3700(a).

Amended by R.1999 d.374, effective November 1, 1999 (operative May 1, 2000).

See: 31 N.J.R. 477(a), 31 N.J.R. 3259(a).

Rewrote the section.

Administrative correction.

See: 32 N.J.R. 684(b).

5:21-7.6 Stormwater management: water quality

(a) The water quality design storm shall be defined as the one-year frequency S.C.S. Type III, 24 hour storm or 1.25 inches of rainfall falling uniformly in two hours.

(b) Where detention basins, wet basins, ponds, constructed wetlands, infiltration structures, dry wells, or other devices are used to control the quantity or rate of post development runoff, then they shall incorporate the measures required by this section in order to protect the quality of surface and subsurface waters. The water quality design storm shall be controlled by best management practices. These include, but are not limited to, the following:

1. In "dry" detention basins, provisions shall be made to ensure that the runoff from the water quality design storm is retained, such that not more than 90 percent will be evacuated prior to 18 hours. The retention time shall be considered a brim-drawdown time and therefore shall begin at the time of peak storage. The retention time shall be reduced in any case that would require an outlet size diameter of three inches or less. Therefore, three-inch-diameter orifices shall be the minimum allowed. This minimum is only for water-quality outlets. If this minimum outlet size does not allow for the detention time required, then additional techniques shall be used to remove total suspended solids.

2. In permanent ponds or "wet" basins, the water quality requirements of this ordinance shall be satisfied where the volume of permanent water is at least three times the volume of runoff produced by the water quality design storm.

3. Infiltration practices such as dry wells, infiltration basins, infiltration trenches, and buffer strips may be used to satisfy this requirement provided they produce zero runoff from the water quality design storm and allow for complete infiltration within 72 hours. Infiltration strategies shall be limited to areas where the soils are suitable to allow infiltration.

4. Suitable best management practices can be found in the following documents:

- i. Stormwater and Nonpoint Source Pollution Control, Best Management Practices Manual, State of New Jersey, Department of Environmental Protection, Office of Land and Water Planning.
- ii. Technical Manual for Land Use Regulation Program, Bureaus of Inland and Coastal Regulations, Stream Encroachment Permits, Revised September 1995, State of New Jersey, Department of Environmental Protection.
- iii. Ocean County Demonstration Study, Stormwater Management Facilities Maintenance Manual, June 1989, State of New Jersey, Department of Environmental Protection, Office of Land and Water Planning.
- iv. Any watershed stormwater management plan.

Amended by R.1999 d.374, effective November 1, 1999 (operative May 1, 2000).
See: 31 N.J.R. 477(a), 31 N.J.R. 3259(a).
Rewrote the section.

APPENDIX

CORRUGATED METAL PIPE STANDARDS

Corrugated metal pipe, when approved by the municipal engineer, shall meet the requirements and be installed in the following manner. Corrugated metal pipe for drainage structures is allowed in accordance with the map below. In areas with acid waters (shaded area on the map), design

engineers may use aluminum alloy, provided the environmental limitations below are met. In neutral/alkaline waters (unshaded on the map), aluminum, aluminum-coated steel type 2, and polymeric-coated steel may be used, provided the environmental limitations below are met. Water pH and resistivity values must fall within the ranges shown below. Samples should be measured in accordance with ASTM G51 and G57. Avoid sampling water during storm events or for two days following a storm to insure more typical readings. If there are severe corrosive conditions (pH <4), fiber-bonded steel pipe should be used.

ENVIRONMENTAL LIMITS FOR CORRUGATED METAL PIPE

Pipe type	pH	Resistivity values (ohm-cm)
aluminum	4-9	> 500
aluminum-coated type 2	5-9	>1500
polymeric coated	5-9	>1500
fiber bonded	<4	—

If the design velocity is greater than 10 feet per second, a one-half bituminous coating and paved invert in accordance with ASTM A849 (AASHTO M190) is required.

Minimum depth of coverage shall be as follows:

MINIMUM DEPTH OF COVERAGE FOR CORRUGATED METAL PIPE

Pipe diameter (inches)	Minimum cover (inches) from top of pipe to bottom of flexible payment or top of rigid pavement
12 inches to 48 inches	12 inches
54 inches of more	Per manufacturer's recommendations

Corrugated aluminum pipe shall conform to the requirements of ASTM B745 (AASHTO M196) for types I, II, IR, IIR, and III.

Corrugated aluminum-coated steel type 2 pipe shall conform to the requirements of ASTM A760 (AASHTO M36) for types I, II, IR, IIR, and III and have an aluminum-one ounce type 2 coating as specified in ASTM A929 (AASHTO M274).

Corrugated polymeric-coated steel pipe shall conform to the requirements of ASTM A762 (AASHTO M36) for types I and II and have a polymeric 10% coating as specified in ASTM A743 (AASHTO M246).

Corrugated fiber-bonded steel pipe shall conform to the requirements of ASTM A760 (AASHTO M36) for types I and II and have an aramid fiber composite coating as specified in ASTM A885. In addition, the pipe shall be bituminous coated as specified in ASTM A849 (AASHTO M190).

Corrugated metal pipe shall be fabricated with annual corrugations by riveted lap joint construction or with helical

corrugations and a continuous weld or lock seam extending from end to end of each length of pipe.

Connecting bands shall be manufactured in accordance with ASTM A760 (steel) or B745 (aluminum) and have the same base metal and coating as the corrugated metal pipe. All pipe ends shall be annularly reformed a minimum of two corrugations.

Fittings and end sections shall be of the same base metal and coating as the corrugated metal pipe.

Corrugated metal pipe shall be installed per ASTM A798 (steel) or ASTM B788.

Maximum cover and structural design of corrugated metal pipe shall be per ASTM A796 (steel) or ASTM B790.

03/05/87

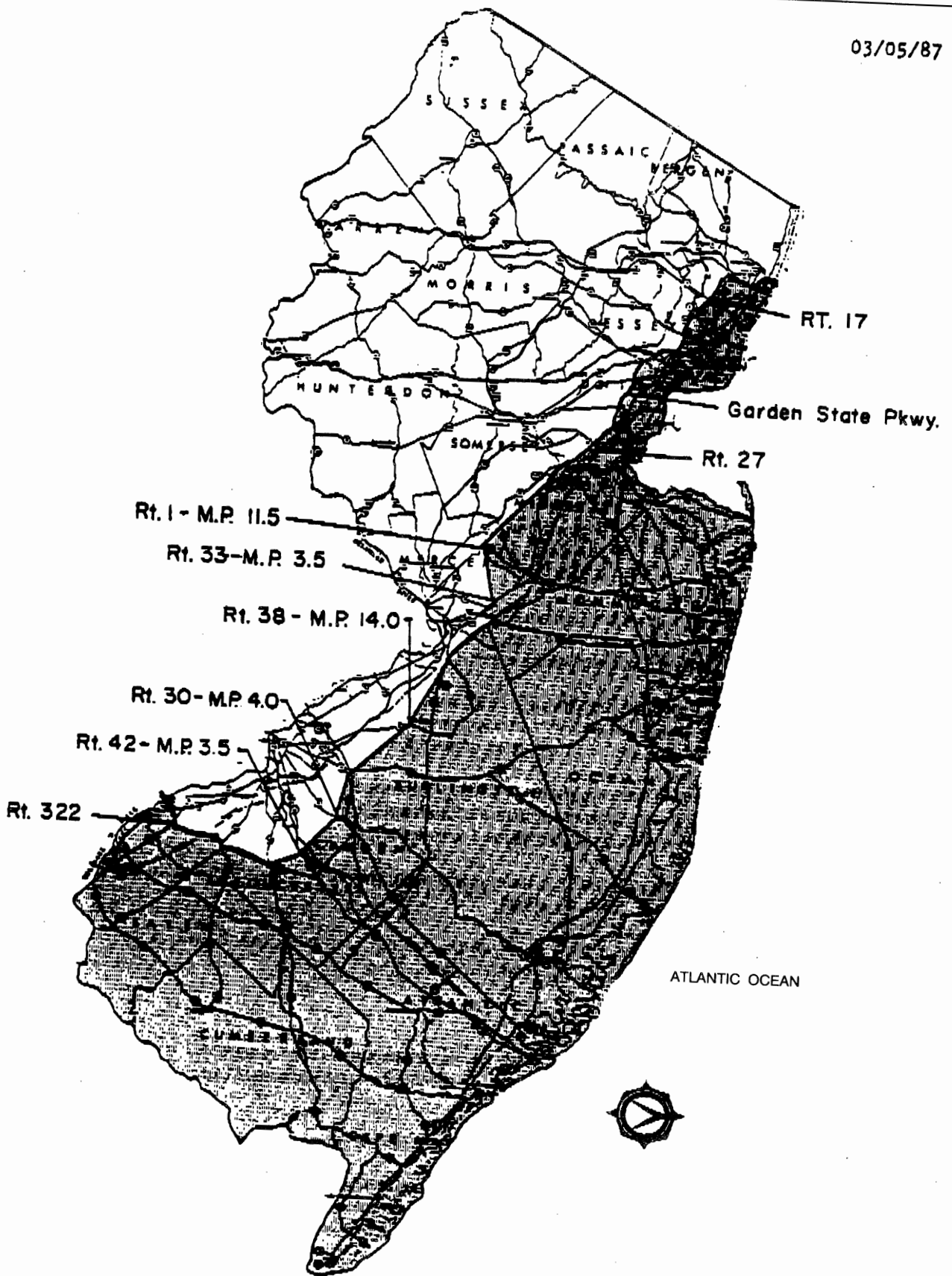

Administrative correction.
See: 29 N.J.R. 1296(a).

SUBCHAPTER 8. REFERENCED STANDARDS

5:21-8.1 Referenced standards

The following is a list of the standards referenced in this chapter. The standards are listed by the promulgating agency of the standard, the standard identification, the edition of the standard, the title of the standard, and the section(s) of this code that reference the standard.

1. American Association of State Highway and Transportation Officials (AASHTO), 444 North Capitol Street, N.W., Suite 249, Washington, DC 20001. Tel. (202) 624-5800 or (800) 231-3475.

<u>Standard reference number</u>	<u>Title</u>	<u>Referenced in N.J.A.C. section number</u>
M33-93	Standard Specification for Preformed Expansion Joint Filler for Concrete (Bituminous Type)	Figure 4.1 (Concrete Vertical Curb)
M43-88	Standard Specification for Sizes of Aggregate for Road and Bridge Construction	Figure 6.1
M114-91 M213-92	Building Brick (Solid Masonry Units Made from Clay or Shale) Standard Specification for Preformed Expansion Joint Fillers for Concrete Paving and Structural Construction (Nonextruding and Resilient Bituminous Types)	5:21-6.2(c)11vii(1) Figure 4.1 (Concrete Vertical Curb)
M252-94	Standard Specification for Corrugated Polyethylene Drainage Tubing	5:21-7.3(d)3
M294-94	Standard Specification for Corrugated Polyethylene Pipe, 12-to 36-in. Diameter	5:21-7.3(d)3
T99-94	Standard Method of Test for the Moisture Density Relations of Soils Using a 5.5-lb. (2.5 kg) Rammer and a 12-in. (305 mm) Drop	5:21-7.3(d)3
1990 Edition	Standard Specification for a Policy on Geometric Design of Highways and Streets	5:21-4.19(b)6 5:21-4.20(a) 5:21-4.20(b)

2. American Concrete Pipe Association, Suite 105, 8618 Westwood Center Drive, Vienna, Virginia 22182. Tel. (703) 821-1990. Concrete Pipe Association of New Jersey, Post Office Box 1013, Dover, New Jersey 07802-1013. Tel. (201) 328-8723.

<u>Standard reference number</u>	<u>Title</u>	<u>Referenced in N.J.A.C. section number</u>
Minimum Cover (Minimum Depth of Coverage over Concrete Pipe)	Published in Concrete Pipe Association of New Jersey Newsletter, "The Pipeline," September/October 1985; table derived from information provided by the American Concrete Pipe Association	Table 7.4

3. American Society for Testing and Materials (ASTM), 100 Barr Harbor, West Conshohocken, Pennsylvania 19428. Tel. (610) 832-9500.

Standard reference number	Title	Referenced in N.J.A.C. section number
A48-92	Standard Specification for Gray Iron Castings	5:21-6.2(c)11v 5:21-7.4(f)
C33-93	Standard Specification for Concrete Aggregates	Figure 6.1
C76-90	Standard Specification for Reinforced Concrete Culvert, Storm Drain, and Sewer Pipe	5:21-6.2(c)6i 5:21-7.3(d)1i
C150-92	Standard Specification for Portland Cement	5:21-6.2(c)11vii(2)
C443-85a (1990)	Standard Specification for Joints for Circular Concrete Sewer and Culvert Pipe, Using Rubber Gaskets	5:21-6.2(c)11iv 5:21-7.3(d)1iii
C478-90b	Standard Specification for Precast Reinforced Concrete Manhole Sections	5:21-6.2(c)11iv 5:21-7.4(d)
C507-90	Standard Specification for Reinforced Concrete Elliptical Culvert, Storm Drain, and Sewer Pipe	5:21-7.3(d)1ii
C700-91	Standard Specification for Vitriified Clay Pipe, Extra Strength, Standard Strength, and Perforated	5:21-6.2(c)6iv
C877-91	Standard Specification for External Sealing Bands for Noncircular Concrete Sewer, Storm Drain, and Culvert Pipe	5:21-7.3(d)1iv
C923-89	Standard Specification for Resilient Connectors between Reinforced Concrete Manhole Structures, Pipes, and Laterals	5:21-6.2(c)11vi 5:21-7.4(d)
D448-86	Standard Classification for Sizes of Aggregate for Road and Bridge Construction	Figure 6.1
D1784-90	Standard Specification for Rigid Poly(Vinyl Chloride) (PVC) Compounds and Chlorinated Poly(Vinyl Chloride) (CPVC) Compounds	5:21-6.2(c)6ii(1)
D1785-91	Standard Specification for Poly(Vinyl Chloride) (PVC) Plastic Pipe, Schedules 40, 80, and 120	5:21-6.2(c)8 Table 7.6
D2241-89	Standard Specification for Poly(Vinyl Chloride) (PVC) Pressure Rated Pipe (SDR Series)	5:21-6.2(c)8 Table 7.6
D2321-89	Standard Practice for Underground Installation of Thermoplastic Pipe for Sewers and Other Gravity Flow Applications	5:21-6.2(c)6ii(2) 5:21-6.2(c)6ii(4) 5:21-7.3(d)3
D2444-92	Standard Test Method for Determination of the Impact Resistance of Thermoplastic Pipe and Fittings by Means of a Tup (Falling Weight)	5:21-6.2(c)6ii(2)
D3034-89	Standard Specification for Type PSM Poly(Vinyl Chloride) (PVC) Sewer Pipe and Fittings	5:21-6.2(c)6ii
D3139-89	Standard Specification for Joints for Plastic Pressure Pipes Using Flexible Elastomeric Seals	5:21-5.3(j)3
D3212-92	Standard Specification for Joints for Drain and Sewer Plastic Pipes Using Flexible Elastomeric Seals	5:21-6.2(c)6ii(3)
D3350-93	Standard Specification for Polyethylene Plastics Pipe and Fittings Materials	5:21-7.3(d)3
F477-90	Standard Specification for Elastomeric Seals (Gaskets) for Joining Plastic Pipe	5:21-6.2(c)6ii(3)
F679-89	Standard Specification for Poly(Vinyl Chloride) (PVC) Large Diameter Plastic Gravity Sewer Pipe and Fittings	5:21-6.2(c)6ii
F789-89	Standard Specification for Type PS-46 and Type PS-115 Poly(Vinyl Chloride) (PVC) Plastic Gravity Flow Sewer Pipe and Fittings	5:21-6.2(c)6ii
F794-91	Standard Specification for Poly(Vinyl Chloride) (PVC) Profile Gravity Sewer Pipe and Fittings Based on Controlled Inside Diameter	5:21-6.2(c)6ii
F949-92	Standard Specification for Poly(Vinyl Chloride) (PVC) Corrugated Sewer Pipe with a Smooth Interior and Fittings	5:21-6.2(c)6ii

4. American Society of Civil Engineers (ASCE), 345 East 47th Street, New York, New York 10017. Tel. (212) 705-7496 or (800) 548-2723.

Standard reference number	Title	Referenced in N.J.A.C. section number
ASCE Manual on Engineering Practice No. 60 1982	Gravity Sanitary Sewer Design and Construction	5:21-6.2(a) 5:21-6.2(c)10 5:21-6.2(c)11
WEF Manual of Practice FD-20 ASCE Manuals and Reports of Engineering Practice No. 77 (1993) ©1992	Design and Construction of Urban Stormwater Management Systems	5:21-7.3(e)

5. American Water Works Association (AWWA), 6666 West Quincy Avenue, Denver, Colorado 80235. Tel. (303) 794-7711 or (800) 926-7337.

<u>Standard Reference number</u>	<u>Title</u>	<u>Referenced in N.J.A.C. section number</u>
ANSI/AWWA C104/A21.4-90	American National Standard for Cement-Mortar Lining for Ductile-Iron Pipe and Fittings for Water	5:21-5.3(j)1 5:21-6.2(c)6iii 5:21-7.3(d)2
ANSI/AWWA C105/A21.5-93	American National Standard for Polyethylene Encasement for Ductile-Iron Pipe Systems	5:21-5.3(j)1
ANSI/AWWA C110/A21.10-93	American National Standard for Ductile-Iron and Gray-Iron Fittings, 3 in. through 48 in. (75 mm through 1200 mm) for Water and Other Liquids	5:21-5.3(j)1
ANSI/AWWA C111/A21.11-90	American National Standard for Rubber-Gasket Joints for Ductile-Iron Pressure and Pipe Fittings	5:21-5.3(j)1 5:21-6.2(c)6iii 5:21-7.3(d)2
ANSI/AWWA C115/A21.15-88	American National Standard for Flanged Ductile-Iron Pipe with threaded flanges	5:21-5.3(j)1 5:21-6.2(c)6iii 5:21-7.3(d)2
ANSI/AWWA C150/A21.50-91	American National Standard for the Thickness Design of Ductile-Iron Pipe	5:21-5.3(j)1 5:21-7.3(d)2
ANSI/AWWA c151/a21.51-96	American National Standard for Ductile-Iron Pipe, Centrifugally Cast, for Water and Other Liquids	5:21-5.3(j)1 5:21-6.2(c)6iii 5:21-7.3(d)2
ANSI/AWWA C300-89	AWWA Standard for Reinforced Concrete Pressure Pipe, Steel Cylinder Type for Water and Other Liquids	5:21-5.3(j)2
ANSI/AWWA C301-92	AWWA Standard for Prestressed Concrete Pressure Pipe, Steel-Cylinder Type, for Water and Other Liquids	5:21-5.3(j)2
ANSI/AWWA C303-95	AWWA Standard for Concrete Pressure Pipe, Bar Wrapped, Steel Cylinder Type	5:21-5.3(j)2
ANSI/AWWA C500-86	AWWA Standard for Gate Valves for Water and Sewerage Systems	5:21-5.3(e)
ANSI/AWWA C502-85	AWWA Standard for Dry-Barrel Fire Hydrants	5:21-5.4(b)1
ANSI/AWWA C504-94	AWWA Standard for Rubber-Seated Butterfly Valves	5:21-5.3(e)
ANSI/AWWA C509-94	AWWA Standard for Resilient Seated Gate Valves for Water Supply Service	5:21-5.3(e)
ANSI/AWWA C600-93	AWWA Standard for Installation of Ductile-Iron Water Mains and Their Appurtenances	5:21-7.3(d)2
ANSI/AWWA C900-89	AWWA Standard for Polyvinyl Chloride (PVC) Pressure Pipe, 4 in. through 12 in., for Water Distribution	5:21-5.3(j)3
ANSI/AWWA C901-88	AWWA Standard for Polyethylene (PE) Pressure Pipe and Tubing, ½ in. through 3 in., for Water Service	5:21-5.3(j)5
ANSI/AWWA C905-88	AWWA Standard for Polyvinyl Chloride (PVC) Water Transmission Pipe Nominal Diameters 14 in. through 36 in.	5:21-5.3(j)3
AWWA M31 ©1992 Second Edition	Manual of Water Supply Practices—Distribution System Requirements for Fire Protection	5:21-5.2(e)

6. Asphalt Institute, Research Park Drive, Post Office Box 14052, Lexington, Kentucky 40512-4052. Tel. (606) 288-4960.

Standard
reference number
MS-1, 8th Edition
August 1970

Title
Thickness Design—Full-Depth
Asphalt Pavement Structures for
Highways and Streets

Referenced in
N.J.A.C. section
number
Table 4.7

7. Institute of Transportation Engineers (ITE), Suite 410, 525 School Street, S.W., Washington, D.C. 20024-2729. Tel. (202) 554-8050.

Standard
reference number
©1989

Title
Residential Street Design and Traffic
Control
Trip Generation

Referenced in
N.J.A.C. section
number
5:21-1.5(d)2

Pub. No. IR-016C
5th Edition
Fourth Printing
January 1991

5:21-4.1(b)
Table 4.1

8. Insurance Services Office, Inc. (ISO), 7 World Trade Center, New York, New York 10048. Tel. (212) 898-6000.

Standard
reference number
©1980
Edition 6-80

Title
Fire Suppression Rating Schedule

Referenced in
N.J.A.C. section
number
5:21-5.2(e)

9. National Fire Protection Association (NFPA), 1 Batterymarch Park, Quincy, Massachusetts 02269. Tel. (617) 770-3000.

Standard
reference number
Standard 291-1995

Title
Fire Flow Testing and Marking of
Hydrants

Referenced in
N.J.A.C. section
number
5:21-5.4(b)2

Standard 1963-1993

Fire Hose Connections

5:21-5.4(b)1

10. New Jersey Department of Agriculture, State Soil Conservation Committee, John Fitch Plaza, PO Box 330, Trenton, New Jersey 08625-0330. Tel. (609) 292-5540.

Standard
reference number
April 1987

Title
Standards for Soil Erosion and
Sediment Control in New Jersey

Referenced in
N.J.A.C. section
number
5:21-7.5(c)
5:21-7.5(f)3.ii

11. New Jersey Department of Environmental Protection (NJDEP), Bureau of Revenue, Maps and Publications Sales Office, 428 East State Street, Trenton, New Jersey 08625. Tel. (609) 777-1038.

Standard
reference number
June 1989

Title
Ocean County Demonstration Study—Stormwater
Management Facilities Maintenance Manual
Stormwater and Nonpoint Source Pollution Control
Best Management Practices Manual

Referenced in
N.J.A.C. section
number
5:21-7.6(c)4

September 1993

Technical Manual for Land Use Regulation Program,

5:21-7.6(c)4

Revised September 1995

Bureaus of Inland and Coastal Regulations, Stream
Encroachment Permits

Table 7.2
5:21-7.6(c)4

August 1995

Pinelands Comprehensive Management Plan
(New Jersey Pinelands Commission)

5:21-5.3(a)
5:21-6.2(a)

12. New Jersey Department of Transportation (NJDOT), 1035 Parkway Avenue, Trenton, New Jersey 08625. Tel. (609) 530-2000.

<u>Standard reference number</u>	<u>Title</u>	<u>Referenced in N.J.A.C. section number</u>
1989	Standard Specifications for Road and Bridge Construction	5:21-4.17(b) Figure 4.1 Figure 4.2 Figure 4.3
May 1992	Design Manual—Roadway (DOT's Division of Roadway Design, Bureau of Roadway Design Standards)	5:21-7.4(a) 5:21-7.2(c)2 5:21-7.2(c)3 Figure 7.1 Figure 7.2

13. New Jersey Society of Municipal Engineers (NJSME), 196 West State Street, Trenton, New Jersey 08608. Tel. (609) 393-0102.

<u>Standard reference number</u>	<u>Title</u>	<u>Referenced in N.J.A.C. section number</u>
Second Edition November 1991	Asphalt Handbook for County and Municipal Engineers	Figure 4.2 Figure 4.3 Table 4.7

14. Portland Cement Association, 5420 Old Orchard Road, Skokie, Illinois 60076-0726. Tel. (847) 966-6200

<u>Standard reference number</u>	<u>Title</u>	<u>Referenced in N.J.A.C. section number</u>
©1984	Thickness Design for Concrete Highway and Street Pavements	Table 4.7

15. United States Army Corps of Engineers, Water Resources Support Center, The Hydrologic Engineering Center, 609 Second Street, Davis, California 95616. Tel. (916) 756-1104.

<u>Standard reference number</u>	<u>Title</u>	<u>Referenced in N.J.A.C. section number</u>
†Technical Paper No. 82 May 1981	The New HEC-1 Flood Hydrograph Package	5:21-7.2(c)

16. United States Department of Agriculture (USDoA), Soil Conservation Service, Post Office Box 2890, Washington, DC 20013. Tel. (202) 205-0026.

<u>Standard reference number</u>	<u>Title</u>	<u>Referenced in N.J.A.C. section number</u>
†Technical Release 20 PB83-223768 May 1982	Computer Program for Project Formulation—Hydrology	5:21-7.2(c) 5:21-7.5(d)
†Technical Release No. 55 PB87-101580 2nd Edition June 1986	Urban Hydrology for Small Watersheds	5:21-7.2(c)1 5:21-7.2(c)3 5:21-7.2(c)6 5:21-7.5(d)1
†Technical Release No. 56 PB85-239622 December 1974	Guide for Design and Layout of Vegetative Wave Protection for Earth Dam Embankments	5:21-7.5(f)5ii
†Technical Release No. 69 PB85-245165 February 1983	Riprap for Slope Protection Against Wave Action	5:21-7.5(f)5ii
†PB85-175164/LT July 1984	Engineering Field Manual for Conservation Practices	5:21-7.5 (f)5vii
†PB 243 644/LT †PB 243 645/LT †PB 279 759/LT	National Engineering Handbook Section 5 Hydraulics Section 11 Drop Spillways Section 14 Chute Spillways	5:21-7.5(f)5vii

17. United States Department of Commerce (USDOC), Bureau of the Census, Washington, D.C. 20233. Tel. (202) 482-2000.

<u>Standard reference number</u>	<u>Title</u>	<u>Referenced in N.J.A.C. section number</u>
1975-1980 (Data tabulated by Rutgers University)	Public Use File—New Jersey	Table 4.4 Table 5.1

18. United States Department of Transportation (USDOT), Federal Highway Administration (FHWA), 820 First Street, S.E., Washington, DC 20002. Tel. (301) 322-4961.

<u>Standard reference number</u>	<u>Title</u>	<u>Referenced in N.J.A.C. section number</u>
AC150/5320-5B July 1970 †Hydraulic Engineering Circular No. 15 Report No. FHWA-EPD-86-111 PB86-184835 October 1975	Airport Drainage Design of Stable Channels with Flexible Linings	5:21-7.2(c)1 5:21-7.5(f)3ii
†Report No. FHWA-TS-79-225 PB83-259903 August 1979	Design of Urban Highway Drainage, The State of the Art	Table 7.3
†Hydraulic Design Series No. 4 Report No. FHWA-EPD-86-103 May 1965 (Reprinted March 1983)	Design of Roadside Drainage Channels	5:21-7.2(c)1
†Hydraulic Design Series No. 5 Report No. FHWA-IP-85-15 PB86-196961 September 1985 ‡1988 Edition	Hydraulic Design of Highway Culverts Manual on Uniform Traffic Control Devices for Streets and Highways	5:21-7.1(h) 5:21-4.13(a)

19. Urban Land Institute, Suite 500 West, 1025 Thomas Jefferson Street, N.W., Washington, D.C. 20007-5201. Tel. (800) 321-5011.

<u>Standard reference number</u>	<u>Title</u>	<u>Referenced in N.J.A.C. section number</u>
ULI-ASCE-NAHB 1975	Residential Storm Water Management: Objectives, Principles, and Design Considerations	Table 7.5

† Documents obtainable from the National Technical Information Service, Springfield, Virginia 22161. Tel. (703) 487-4650.

‡ Documents obtainable from the United States Government Printing Office, Superintendent of Documents, Post Office Box 371954, Pittsburgh, Pennsylvania 15250-7954. Tel. (202) 512-1800.

Administrative correction.

See: 29 N.J.R. 1296(a).

Administrative correction.

See: 29 N.J.R. 2816(a).

Amended by R.1999 d.374, effective November 1, 1999 (operative May 1, 2000).

See: 31 N.J.R. 477(a), 31 N.J.R. 3259(a).

Rewrote the section.

Administrative correction.

See: 32 N.J.R. 684(b).