

90 RS28

1980b

FHWA/NJ-81/001
81-001-7799, ITEM 3.

BREAKAWAY CABLE TERMINAL EVALUATION

FINAL REPORT

BY

ROBERT F. BAKER

DEPARTMENT LIBRARY
N.J. DEPT OF TRANSPORTATION
TRENTON, NEW JERSEY

MAY 1980

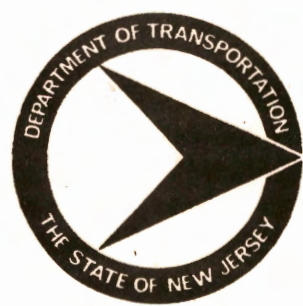

Prepared By
New Jersey Department of Transportation
Division of Research and Demonstration
In Cooperation With
U.S. Department of Transportation
Federal Highway Administration
New Jersey State Library

1. Report No FHWA/NJ-81/001	2. Government Accession No	3. Recipient's Catalog No	
4. Title and Subtitle Breakaway Cable Terminal Evaluation		5. Report Date May, 1980	6. Performing Organization Code
		8. Performing Organization Report No 81-001-7799	
7. Author(s) Robert F. Baker	9. Performing Organization Name and Address New Jersey Department of Transportation 1035 Parkway Avenue Trenton, New Jersey		10. Work Unit No
12. Sponsoring Agency Name and Address Federal Highway Administration Washington, D.C.			11. Contract or Grant No NJ HPR 7799 Item 3
12. Sponsoring Agency Name and Address Federal Highway Administration Washington, D.C.		13. Type of Report and Period Covered Final Report	
		14. Sponsoring Agency Code	
15. Supplementary Notes			
16. Abstract <p>On the recommendation of the Federal Highway Administration the New Jersey Department of Transportation selected the "Breakaway Cable Terminal" (BCT) for use as a guiderail end treatment in 1976. The selected design included 6" x 8" wood posts, an unstiffened buffer end, a bossed bearing plate and a one-piece anchor plate. The objective of this study was an evaluation of the in-service performance of BCTs. Thirteen impacts between vehicles and BCTs were evaluated for accident performance. The results of the in-service evaluation were compared with the full scale crash tests previously conducted by the Southwest Research Institute.</p> <p>The New Jersey in-service experience was similar to the initial tests by SwRI and the BCT is warranted for flared guiderail installations. Small car spearing occurred with end-on impacts (no flare) on straight guiderail sections. A recommendation was made to reinforce the unstiffened buffer end on straight guiderail sections.</p> <p>In several instances the spliced rail sections did not facilitate rail separation from the posts probably causing the stiffened rail to penetrate (spear) the vehicle. A recommendation was made to replace the two twelve and a half foot sections with one twenty-five foot section essentially eliminating the splice. Vehicle rebounding occurred and was apparently due to the operators' reactions at the time of impact. In some instances curbs and shoulder berms appeared to cause ramping of the vehicle on impact. Recommendations were made to closely follow the SwRI provisions for the BCT installation.</p>			
17. Key Words Guiderail end treatment Safety		18. Distribution Statement Copies available on request	
19. Security Classif. (of this report) Unclassified	20. Security Classif. (of this page) Unclassified	21. No. of Pages 43	22. Price

*

'

'

*

Notice

This publication is disseminated in the interest of information exchange.

The opinions, findings and conclusions expressed in the publication are those of the author and not necessarily those of the New Jersey Department of Transportation or the Federal Highway Administration.

This report does not constitute a standard, specification or regulation.

•

•

/

,

,

•

•

Table of Contents

	<u>Page</u>
List of Figures, Pictures and Tables	v
Summary and Conclusions	1
Recommendations	4
Introduction	7
BCT Development	8
Effect of Vertical Curbing on Guiderail Performance	20
Discussion of Monitoring Experience	21
Miscellaneous BCT Damage	28
Estimation of Recovery Area Behind BCT	29
References	31
Appendix	32

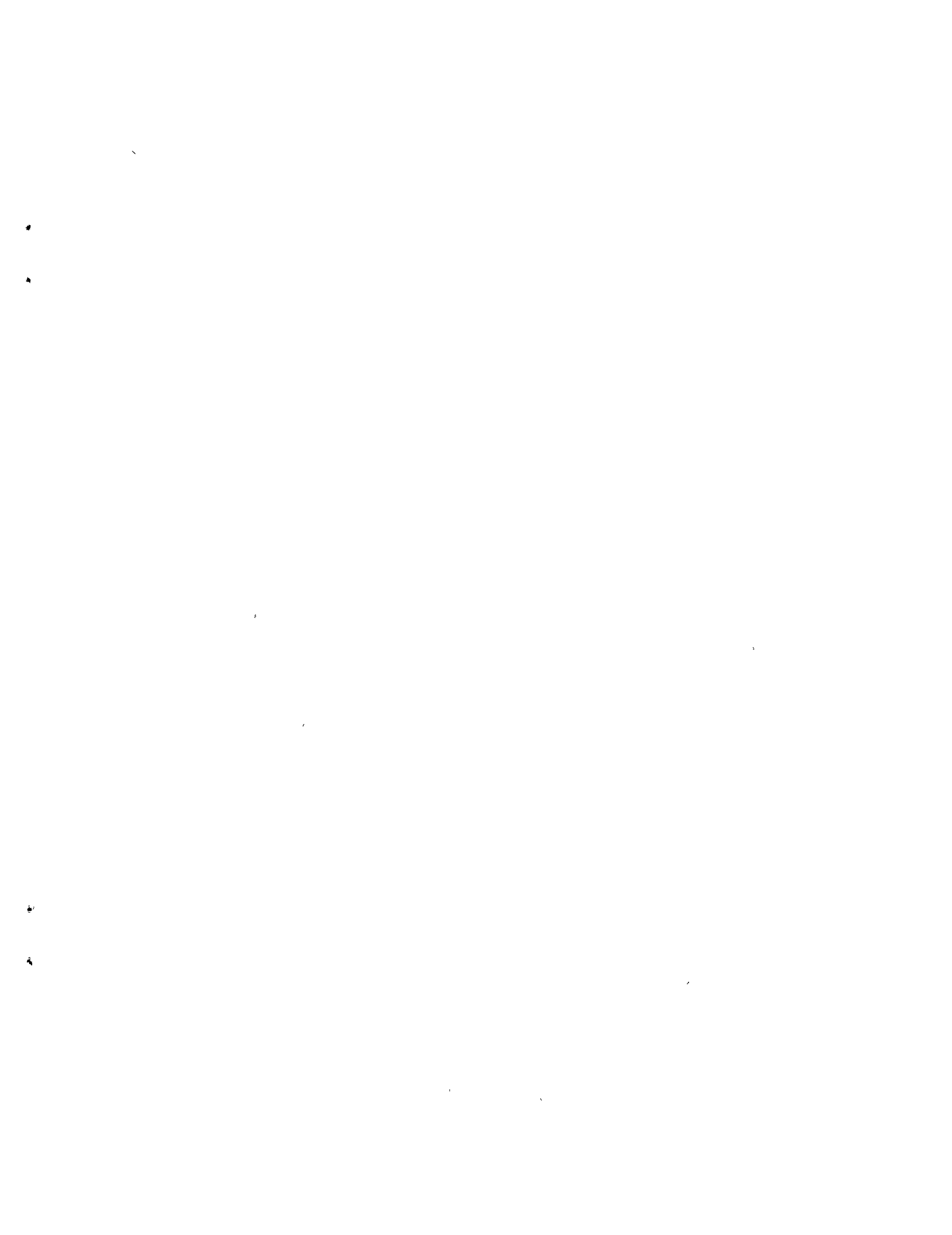

List of Figures, Pictures and Tables

<u>Figure</u>	<u>Page</u>
1 - Installation Drawing of Breakaway Cable Terminal	9
2 - Crash Test Results (flared guiderail)	13
3 - Crash Test Results (downstream impact)	14
4 - Crash Test Results (straight guiderail)	16
5 - New Jersey Breakaway Cable Terminal Design	19
6 - Recovery Area	30

<u>Picture</u>	
1 - Speared Chevrolet Vega	27

<u>Table</u>	
1 - Breakaway Cable Terminal Concept Performance Principles	10

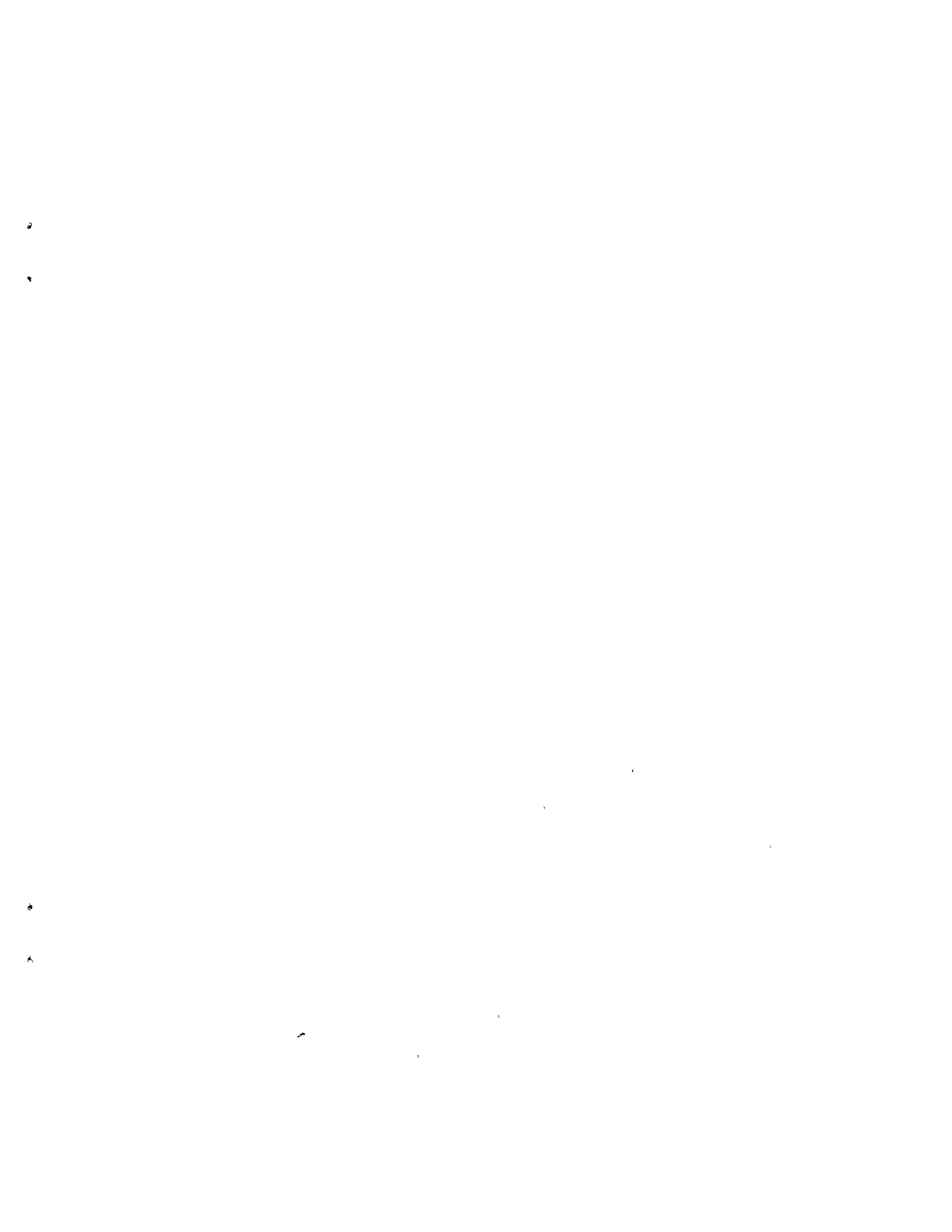

Summary and Conclusions

On the recommendation of the Federal Highway Administration the New Jersey Department of Transportation adopted the Breakaway Cable Terminal (BCT) for use as a guiderail end treatment in 1976. Concurrent with that action, the Federal Highway Administration requested a two year monitoring period to evaluate the in-service performance of the terminal. The BCT guiderail end treatment is designed specifically to prevent vehicle spearing, to redirect errant vehicles and to minimize hazard to vehicle occupants.

The Southwest Research Institute conducted full-scale crash tests (Ref. 1 and 2) to evaluate preliminary BCT designs. Initial crash tests evaluated the angle impact with a flared guiderail, the downstream impact to test anchorage strength and the end-on impact with a straight guiderail section. Additional component testing emphasized several design modifications which culminated in the present BCT design. This design incorporates the 6" x 8" wood posts, the undiaphragmed buffer end (on flared guiderail), a bossed bearing plate and one piece anchor plate. (See Figure 5 in text.)

The New Jersey in-service impact experience is compared to the three preliminary Southwest Research Institute's full-scale crash tests. The New Jersey experience was similar to the three SwRI tests, however, small car spearing was found to occur with end-on impacts on straight guiderail sections (parallel to the roadway). The following summation emphasizes the important aspects of thirteen impacts for which adequate documentation could be obtained.

The vehicle spearing phenomena occurred in three cases where the undiaphragmed BCT was installed on a straight guiderail section. (Accident cases #7,8,10) The vehicles were a subcompact, a compact and a van with small engines, and no substantial mass in the engine compartment to impact an object. Apparently, as a consequence of this condition the guiderail was able to penetrate vehicle. In large vehicles (Accident cases #11,12,13) air conditioning units, V-8 engines and other engine compartment components provide a substantial mass to impact the BCT and prevent spearing. Since the small vehicles do not possess a high engine compartment mass, the BCT must be designed to provide for this condition. Undiaphragmed BCTs apparently do not provide sufficient distribution of impact load for the lighter subcompacts. Instead, when the subcompacts impact the BCT, it appears that the flimsy unsupported buffer nose collapses and the guiderail becomes a spear. The diaphragmed buffer nose provides greater mass for load distribution during the small car impacts.

The rebound phenomena occurred in two cases. (Accident cases #3,6) The rebound phenomena is the reaction of the vehicle after impact and is a springing back on collision. In both cases, the vehicle rebounded across the opposite roadway and presented a possibility for secondary collision. The rebounding phenomena is believed to be explained by the corrective reaction of the vehicle operator at the time of impact.

Separation of the guiderail from washerless retainer bolts did not occur in all cases. This is believed to have been caused by the overlap stiffness of the two 12 foot rails at the third post. The rail must separate from the post to reduce the column loading on the rail. By providing a single 25 foot rail section, the overlap stiffness will be reduced and the rail should separate from the bolt.

Pushed over (dislodged) concrete footings occurred in three cases. (Accident cases #5,11,13) All three cases were newly installed with loose backfill. The displaced footing is caused by incomplete compaction of the soil around the footing.

Vehicle ramping occurred in two cases. (Accident cases #1,9) The impacting vehicle ramps, i.e., apparently climbs upon the top of the guiderail, when the guiderail is behind a vertical curb or on a berm. In the most severe case of ramping (Accident case #9), the vehicle rode on top of guiderail and overturned. In the other case (Accident case #1), the vehicle ramped and impacted on top of the BCT. The Southwest Research Institute (Ref. 1, pg. 45) recommended that the installation of the BCTs be avoided on berms or immediately behind vertical curbs.

Recommendations

The Department's use of the Breakaway Cable Terminal guiderail end treatment is warranted in specific applications. Ideally, the present design with undiaphragmed buffer end and 6"x8" wood posts should be installed on a parabolic flared (horizontal) guiderail. However, the New Jersey straight horizontal flare of 15:1 is acceptable for median and shoulder installations.

The application of the present BCT design (see Figure 5 in text) should reflect careful attention to the following aspects of installation which significantly influence the terminal's performance:

1. Horizontal-end flare is essential to minimize W-beam stiffness and facilitate end hit penetration behind the guiderail reducing the potential for spearing.

2. Recovery areas immediately behind the BCT and along the probable vehicle path for expected end hit penetration should be free of obstructions. The minimum recovery area and probable area of vehicle penetration are defined from this study and Southwest Research Institute's research by the diagonal line from the edge of the traveled way through the point of theoretical end of guiderail need to the obstruction, and a line parallel to that line running six feet from the end of the BCT to the line of the obstruction. (See Figure 6 in text.) Engineering judgment should be exercised where sufficient recovery areas are not possible. Such solutions as extension of the length of need, clearing and regrading the site, removing and installing protective barriers should be considered.

3. Installation site constraints. For optimum performance of the BCT, the terrain should be level and as free of impediments as possible. The use of BCTs on raised shoulder berms (or islands) or immediately behind vertical curbs is not recommended by Southwest Research Institute (Ref. 1, pg. 45) and the New Jersey Department of Transportation's monitoring experience. However, the California Department of Highways indicates that guiderail should not be installed behind a vertical curb which exceeds 6" in height. Using engineering judgment, existing BCTs behind vertical curbs greater than 6" should be considered for corrective action.

The concrete footing in the first post is essential for guiderail post anchorage in downstream impact conditions. Loose soil around the concrete footings should be adequately compacted to insure post anchorage.

The spearing potential of straight guiderail, parallel to the roadway, is definitely real. After three confirmed spearings, it is recommended that the Department avoid applications of BCTs on the straight guiderail. However, in areas where the BCT cannot be flared, and a straight installation is unavoidable, a desirable configuration would be one that has the undiaphragmed buffer end replaced by a diaphragmed buffer end and contains a 25 foot rail section to eliminate the splice stiffness. The steel diaphragmed buffer end was tested by Southwest Research Institute (Ref. 2, pg. 56) in straight end-on impacts with a 4000 lb. vehicle. The vehicle was not speared because the stiffened buffer end distributed the impact load over a larger area than the undiaphragmed buffer end.

A problem statement should be submitted to the National Cooperative Highway Research Program requesting additional tests to redesign the BCT for straight guiderail installations. This program should include crash tests with light subcompact and mini vehicles. The test program should investigate possible modifications to the buffer end to reduce the spearing potential and modifications to facilitate the separation of the rail and third post. As stated above, the SwRI tested a 25 foot rail to eliminate the stiffened splice at the third post. However, this length of rail is difficult to handle when making maintenance repairs. Of particular concern is the problem of safely transporting the rail to the repair site.

Another area of concern is the use of the BCT behind existing vertical curbs and raised berms. Modifications to the guiderail height and minimum horizontal distance between guiderail and curb must be determined for maximum BCT performance.

The final problem area involves the location of obstacles behind the BCT in the vehicle recovery area. In urban areas the obstacle can often not be removed and sufficient space is not available for an attenuation system. In such instances, an alternate protective system should be developed to minimize the damage incurred by vehicles striking it.

An NCHRP research project should include full-scale testing of suggested solutions and such tests should emphasize the small, lightweight vehicles which are coming into increased use today.

Introduction

The unprotected end of the W-Beam guiderail has been shown to be hazardous to an errant vehicle. The untreated W-Beam guiderail has penetrated the passenger compartment in numerous end-on impacts causing serious personal injury. A solution to the problem is the "Breakaway Cable Terminal", (BCT) which is named for the design principle.

On the recommendation of the Federal Highway Administration, the first BCTs on New Jersey guiderails were installed in spring 1976. Since this type of end treatment was essentially new in New Jersey, the Department agreed to participate in the Federal Highway Administration's national monitoring effort of the BCTs performance. The monitoring effort included field inspection of all accident sites, pictures of the vehicles and the sites, accident reports for every reported impact with each BCT or with connected guiderail within 75 feet of a BCT. This data were recorded on a special form designed for reporting such accidents. The Department's Maintenance forces served as the first line surveillance group with accident reports being completed by the Division of Research and Development. An example of the form used in reporting these accidents is shown in the Appendix.

The initial monitoring effort included fifty BCT installations on various construction projects. When the monitoring of the fifty BCTs on various projects became logistically difficult, four specific construction projects of BCT safety improvements were selected instead of the original fifty BCTs on various projects. The four construction projects were (1) Route N.J. 57, Sections 1A, 2A, 3A, and 4B, (2) Route I-287,

Sections 11F and 12F, (3) Route U.S. 206, Sections 6A and 7A, and (4) five sites in rural Burlington county. Each BCT was assigned a unique number and inspected for concurrence with construction specifications. After an inactive period of BCT impacts on the four projects, the Division of Research and Development requested that maintenance personnel additionally monitor all BCT impacts in District 1 (Hunterdon, Warren, Morris, Somerset and Sussex Counties). Due to the enormous number of BCTs in District 1, numbering and initial inspection was not performed on these BCTs.

BCT Development

The National Cooperative Highway Research Program sponsored the development of twelve various end terminal concepts. From the twelve concepts, three guiderail terminals were selected for evaluation and full scale crash tests. After preliminary evaluation, the "breakaway cable terminal" concept was finalized and full scale crash tests were performed to evaluate the dynamic performance of the BCT design principles which are shown in Table 1.

The design objectives of the BCT and the basis for the Department's functional evaluation of the BCT is specifically to prevent vehicle spearing, to redirect errant vehicles and to minimize hazard to vehicle occupants on impact. An early design of the BCT is shown in Figure 1.

Table 1

Breakaway Cable Terminal Concept Performance Principles*

Component or Feature	Design Function	
	End-On Impacts (Flared)	Downstream Impacts
1. End Post	Post "breaks away" at bored hole, releasing cable, thus minimizing spearing forces.	Post is designed to transfer breaking strength of cable to the concrete footing.
(a) Bearing Plate	No Function	Distribute horizontal forces from cable to post. Size was determined from breaking strength of southern pine.
2. Buffer Nose	Diaphragmed nose distributes loads over a large area; thus reducing chances of rail penetrating into passenger compartment. Unstiffened nose has no function.	No Function

*Table 1- Breakaway Cable Terminal Concept Performance Principles, NCHRP Report 129, Guardrail Crash Test Evaluation, Highway Research Board, 1972 p. 6

3. Anchor Cable

Cable does not perform for end-on impacts, but it is essential that it does not develop spearing forces in W-Beam.

Cable transfers tensile forces from beam to end post. Proper anchorage is essential for angle impacts downstream from the end.

4. Concrete Footing

Restricts movement of post.

Distribute loads from end post to soil.

5. End Flare

Induce eccentric loads for end-on impacts, thus bending beam away from vehicle.

No Function

In conjunction with the National Cooperative Highway Research Program, the Southwest Research Institute (SwRI) conducted Phase I crash tests^(1,2) to evaluate the terminal's performance for (1) end-on impact with flared end, i.e., essentially, an angle impact which produces an eccentrically loaded column, (2) an angular impact downstream from the terminal and (3) end-on impact on a straight guiderail, i.e., essentially column loaded.

The first test (Figure 2) was conducted to evaluate the performance of an end-on impact with a parabolically flared guiderail, i.e., eccentrically loaded. The BCT design was similar to Figure 1 except that the nose was filled with vermiculite concrete to maintain nose geometry and to distribute forces over a large section of the vehicle. A 4138 lb., 1965 Ford sedan impacted the nose at 61 mph at 0 degrees from the typical rail line. (This is approximately 20 degrees to the flare BCT.) The end post and second post broke at the breakaway holes as designed. The vermiculite-filled nose and the W-beam rotated about the third post to the rear of the installation. The vehicle was "redirected" behind the guiderail and appeared dynamically stable during impact and deceleration.

The second test (Figure 3) was conducted to evaluate the anchorage strength of the terminal assembly. The BCT design was similar to Figure 1 with the exception of a vermiculite-filled nose. The 4000 lb. vehicle impacted the guiderail at an angle of 15 degrees at 59 mph. The initial point of impact was four (4) feet downstream from the second post. The vehicle was redirected with a rebound distance of 49 feet and braked to a

Figure 2

**CRASH TEST RESULTS ADAPTED FROM GUIDERAIL
CRASH TEST EVALUATION, NCHRP REPORT 129
HIGHWAY RESEARCH BOARD, 1972**

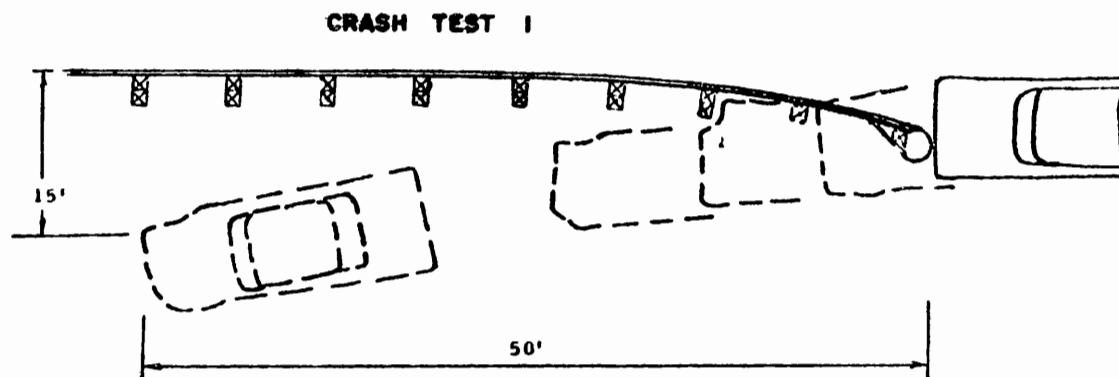

Test Installation .. Flared Terminal*
Posts 8 x 8 Timber
Post Spacing 6.25 ft
Rail Standard 12ga W beam
Length of Installation 87.5 ft
Ground Condition Dry

Test No. 130
Date 6-11-71
Vehicle 1965 Ford
Vehicle Weight .. 4138 lbs
Impact Speed 61 mph
Impact Angle 0 deg**

*Flared terminal for NCHRP Report 118 System G4W, see Figure A 20
**Measured from typical rail line

Figure 3

CRASH TEST RESULTS ADAPTED FROM GUIDERAIL
CRASH TEST EVALUATION, NCHRP REPORT 129
HIGHWAY RESEARCH BOARD, 1972

CRASH TEST 2

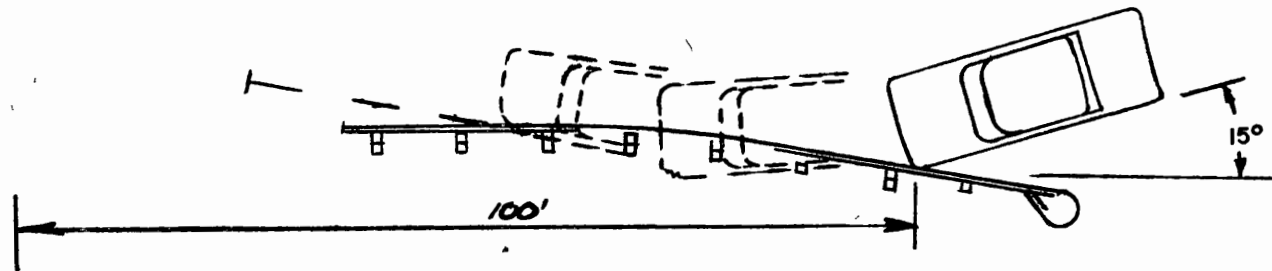

Test Installation ... Flared Terminal*
Posts 8 x 8 Timber
Post Spacing 6.25 ft
Rail Standard 12ga. W beam
Length of Installation 87.5 ft
Ground Condition Dry

Test No. 131
Date 7-17-71
Vehicle 1963 Ford
Vehicle Weight .. 4000 lbs
Impact Speed ... 59.4 mph
Impact Angle 15 deg

*Flared terminal for NCHRP Report 118 System G4W, see Figure A-20

stop 108 feet from the initial point of impact. The cable anchor system, end posts, and foundation were not damaged in the test.

The installation for the third test (Figure 4) was similar to the previous tests with the exception that steel diaphragms replaced the vermiculite concrete for stabilizing the terminal nose and the flat plate washers were eliminated from the first 6 posts to achieve rail separation from the post. The horizontal flare was eliminated; essentially, the BCT and guiderail installation were parallel to the roadway and column loaded.

A 4,100 lb. vehicle impacted the terminal end at 58.5 mph and at an angle of 0 degrees. The end post broke through the bored hole and initially the rail remained straight until 0.3 seconds into the test when the rail began to flex immediately before the fourth post. At 0.4 seconds, with first section of rail still straight, the vehicle began an upward pitch of 17 degrees. The vehicle came to rest 34 feet from the initial point of impact.

The omission of the flat plate washers achieved rail separation from the first 6 posts. However, in the initial 0.3 seconds of the test, the rail remained straight and penetrated the vehicle's engine compartment. If the vehicle did not have a substantial mass in the engine compartment, the rail would have penetrated into the passenger's compartment.

The initial tests demonstrated the design performance of the BCT concept. For end-on impacts, the curvature of the flared terminal introduces eccentric vehicle forces into the rail, thereby reducing the column strength of the rail and reducing the magnitude of the vehicle forces. The downstream impact to test the anchorage strength indicated

Figure 4.

CRASH TEST RESULTS ADAPTED FROM GUIDERAIL
CRASH TEST EVALUATION, NCHRP REPORT 129
HIGHWAY RESEARCH BOARD, 1972

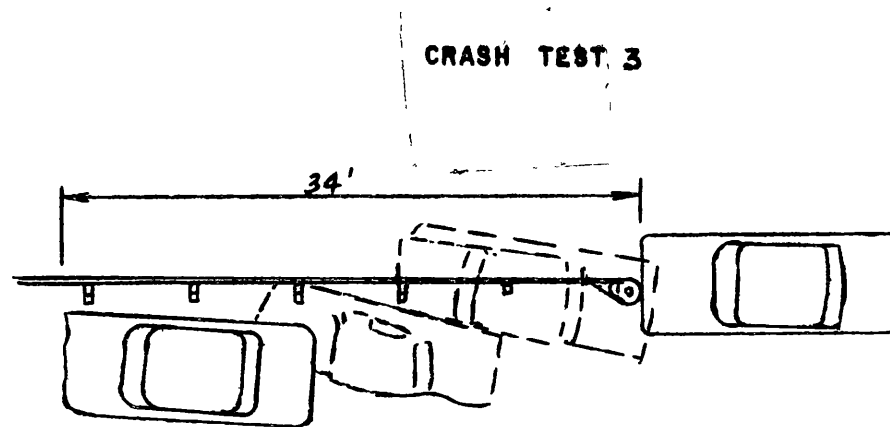

Test installation ... Straight Terminal*
Posts 8 x 8 Timber
Post Spacing 6.25 ft
Rail Standard 12ga. W beam
Length of Installation 87.5 ft
Ground Condition Wet

Test No. 132
Date 8-16-71
Vehicle 1964 Ford
Vehicle Weight .. 4100 lbs
Impact Speed ... 58.5 mph
Impact Angle 0 deg

*Straight terminal for NCHRP Report 118 System G4W, see Figure A-20

that the cable, anchorage plate and bearing plate retained the rail. For the end-on impact on the parallel guiderail, the vehicle pitched upward and came to rest behind the guiderail. The column strength of the rail was evident by the late flexing of the unrestrained rail.

After additional Phase I tests with steel posts and subcompact vehicles, the breakaway cable terminal (Figure 1) which utilized two 8 x 8 inch timber posts set in concrete footings, was recommended for trial in-service use. Its performance was satisfactory except for low speed, end-on (flared) impacts with subcompact vehicles. Subsequently, the objectives of the second phase of the NCHRP Project 22-2 were component tests to improve the performance of the BCT for end-on (flared) impacts with small cars and to refine the BCT design for improved economy. The component tests resulted in the development of steel breakaway terminal posts to utilize slip bases and the elimination of diaphragm plates in the buffer nose to minimize costs.

Verified by pendulum tests and additional component testing, second phase design modifications were suggested for the timber post BCT terminals. The first two timber posts were changed from 8 x 8 inches to 6 x 8 inches and the bearing plate was modified by increasing the thickness to 3/4 inch and by adding a 3 inch boss at the bottom and a 1 inch boss at the top. The redesigned bearing plate provides the necessary anchor strength for the 6 x 8 inch post on downstream impacts. Later, Research by California⁽²⁾ suggests that a flat symmetrical bearing plate will be sufficient to retain the anchor.

Other significant modifications to the BCT were: (1) a one piece anchor plate to replace the more costly welded anchor plate to secure the cable to the rail element, (2) the height of the hole in the first and second post above the concrete footing was lowered to 4 inches to reduce the possibility of snagging a small vehicle on the portion of the sheared off post extruding above the concrete foundation, and (3) steel diaphragms were eliminated from the nose element. The diaphragms were found to not only increase cost of the nose, but to present certain difficulties in hot dip galvanizing. The latter problem was circumvented by adding weep holes which allow the zinc to drain.

The Southwest Research Institute demonstrated in five crash tests that the use of a BCT nose assembly without diaphragm plates was considered satisfactory. However, none of these tests investigated the unstiffened nose assembly with wood posts and small subcompact cars. Additionally, the unstiffened nose and wood posts were not tested for an end-on impact on a straight section of guiderail parallel to the roadway.

The current New Jersey BCT design (Figure 5) incorporates the 6 x 8 inch wood posts with a breakaway hole 4 inches from the top of concrete, bossed bearing plate, welded anchor plate and undiaphragmed nose on flared guiderail installations. A diaphragmed nose and 25 foot rail to replace the two 12 foot sections are used on guiderail installation which parallel the roadway. The flat plate washers which retain the guiderail to the post are eliminated on the first 37½ feet of the BCT installation.

Effect of Vertical Curbing on Guiderail Performance

Crash tests involving vertical curbs placed in front of guiderails are reported by Beaton and Field⁽³⁾. The 6" vertical curb had little effect on either the rise or redirection of the vehicle. However, striking the 8" vertical curb caused an immediate dynamic jump by the vehicle. The tests by Beaton and Field of the California Department of Highways were with 1951 - 1955 4000 lb. vehicles.

Discussion of Monitoring Experience

Initial construction problems with BCT installations were encountered on several guiderail projects. Specific problems included oversized buffer ends, improper height of the breakaway hole in the first two posts, upside down bearing plates and the placement of retainer washers between the retainer bolts and the guiderail. The oversized buffer ends were replaced, bearing plates uprighted and retainer washers removed for the first 37'-5" of guiderail. A tolerance of + 0 inches - ½ inch from the center of the breakaway hole to the top of the concrete footing was initiated to facilitate height requirements.

Maintenance problems were encountered with wood post removal after an impact. California⁽²⁾ experimented with styrofoam pads between the post and concrete footing. It was concluded that the pads did not significantly improve the ability to remove the broken posts.

During the two year monitoring period, thirty-three BCT impacts were investigated by the Division of Research & Development. From the thirty-three impacts which the Department investigated, thirteen BCT impacts are discussed in this report. In the remaining twenty impacts, accident information was incomplete due to the unavailability of the impact date of damaged BCTs. Without an accident date, it was impossible to obtain the Motor Vehicle accident reports and inspect the vehicle. In some cases, the BCT was repaired before the Division of Research made an inspection.

The thirteen BCT accident cases with adequate accident information are compared with BCT crash test performance of the SwRI. In review, the first SwRI crash test was essentially at an angle to the BCT and guiderail. The second SwRI crash test was a downstream impact to determine the anchor strength capability. The third SwRI crash test was an end-on impact at 0 degrees to the guiderail.

The following five BCT accident cases (Appendix A-1 through A-5) of angle impacts, i.e., an eccentric loading, were similar to the first SwRI crash test. The vehicles in the five cases impacted the buffer nose at angles between 20-30 degrees to the BCT. The New Jersey guiderail design uses a straight horizontal flare of 15:1. Two BCT impacts (Accident cases #2&3) in the following discussion were on horizontally flared guiderail sections. The other three impacts (Accident cases #1,4&5) were on straight guiderail (parallel to the roadway). The approximate impact angle was determined from skid marks and an engineering evaluation at the site.

Case #1: A 1969 Volkswagon beetle impacted a BCT at a point immediately behind the buffer nose connection at the first post. The BCT was installed in a gore area behind an 8-inch vertical curb which probably ramped the vehicle causing it to impact the buffer nose connection at bumper height. The vehicle bent the rail between the first and second post, and broke the first post at ground level below the breakaway hole. The vehicle passed behind the guiderail and sustained substantial front and undercarriage damage. The driver was injured seriously.

Case #2: A 1971 Chevrolet struck a BCT at the buffer end. The BCT was installed on a shoulder berm and horizontally flared. The vehicle compressed the undiaphragmed buffer end and split the post vertically through the center. The vehicle sustained slight damage and passed behind the guiderail. No injuries were reported.

Case #3: A 1975 Pontiac impacted a BCT at the buffer end. The BCT was installed on a horizontally flared guiderail in the median. The vehicle compressed the undiaphragmed buffer end and broke the first post at ground level below the breakaway hole and fractured the top of the post. Although retaining washers were eliminated, the rail remained attached to the second wood post and the steel posts. The vehicle sustained front damage to the radiator and engine. After the impact, the vehicle rebounded into the opposite roadway. No injuries were reported.

Case #4: A 1976 Ford impacted a BCT at the buffer end. The BCT was installed behind an 8-inch vertical curb on a guiderail section parallel to the roadway. The slow moving vehicle broke the first post at ground level and bent the guiderail between the first and second post. The rail separated from the second wood post but did not separate from the steel posts. The vehicle was damaged moderately in the front and right front fender. No injuries were reported.

Case #5: A 1964 Rambler impacted a BCT at the buffer end. The BCT was installed on the shoulder berm directly in front of a utility pole. The vehicle compressed the undiaphragmed buffer end

and pulled the concrete footing from the ground without breaking the post. The vehicle impacted the utility pole immediately behind the BCT. The four vehicle occupants were injured seriously.

Two incidents of BCT impacts occurred downstream from a BCT. In these two accident cases, automobiles impacted twenty-five feet downstream from the BCT. The rail separated from steel posts and the vehicles were redirected away from the guiderail. The BCTs in both incidents were not damaged; i.e., the anchor cable of the BCT retained the guiderail. Division of Motor Vehicles accident reports were not available for the above cases.

The following eight BCT accident cases (Appendix A6-A-13) of end on impacts were similar to the third SwRI crash test. The guiderail installations are parallel to the roadway, and the vehicle impacts the buffer nose at a 0 degree angle to the guiderail, i.e., the guiderail is column loaded.

Case #6: A 1972 Chevrolet impacted the diaphragm buffer nose as described above. The BCT was located at the edge of the roadway behind an 8-inch vertical curb. The vehicle split vertically the first post through the retainer bolt and pushed the buffer nose behind the broken post. The vehicle sustained front end damage to the radiator and engine. After the impact, the vehicle rebounded across the two-lane road into a front yard. The road was snow covered. No injuries were reported.

Case #7: A 1973 Ford Van impacted an undiaphragmed BCT. The BCT was located behind an 8-inch vertical curb. The vehicle broke the first and second post at ground level. Although it was not possible to locate the vehicle for inspection, the following statement was made by the investigating officer, "vehicle struck guiderail forcing rail through grill of vehicle and out rear of driver's door". The driver was injured moderately.

Case #8: A 1972 Dodge Dart impacted an undiaphragmed BCT. The BCT was located at the edge of the roadway. The vehicle broke the first and second wood posts. Although the retainer washers were eliminated, the guiderail did not separate from the steel posts. The straight guiderail penetrated into the engine compartment and pushed the fire wall into the passenger seat. (The column loaded rail section did not bend away from the vehicle.) The driver was injured seriously.

Case #9: A 1970 Chrysler impacted an undiaphragmed BCT. The BCT was located on the road berm. The vehicle broke the first post above the bearing plate (the bearing plate remained in place after the accident). The second post was broken at ground level. The third, fourth and fifth steel posts were pushed over. The concrete footing of the first post was cracked vertically. The rail was pushed down and separated from the washerless retainer bolts. The buffer end was torn off. It was reported by the investigating officer that the "vehicle rode on top of the guiderail for 80 feet" before overturning down an embankment. The vehicle was severely damaged. The driver was injured seriously.

Case #10: A 1972 Chevrolet Vega impacted an undiaphragmed BCT. The BCT was located at the edge of the roadway on a straight guiderail section, i.e., without horizontal flare. The vehicle broke the first and second wood posts at ground level. The guiderail speared the vehicle into the driver's seat pushing the driver's seat backward. Picture #1 shows the speared Vega: Note position of guiderail. The vehicle was severely damaged. The rail remained straight and did not separate from the washerless retainer bolts on the steel posts. The driver was injured seriously.

Case #11: A 1977 Chevrolet impacted an undiaphragmed BCT. The BCT was located behind an 8" vertical curb. The vehicle pushed over the first wood post and concrete footing and compressed the buffer end. The vehicle damage was confined to the engine compartment. The driver and a passenger were injured moderately.

Case #12: A 1977 Chevrolet Van impacted an undiaphragmed BCT. The BCT was located behind an 8-inch vertical curb. The vehicle broke the first and second wood posts at ground level. The guiderail was bent at the buffer end connection to the guiderail. The vehicle sustained extensive front end damage. Guiderail penetration into the vehicle was prevented by a large V-8 engine, an air-conditioning unit and radiator. The driver was injured moderately.

Case #13: A 1972 Plymouth Satellite impacted an undiaphragmed BCT. The BCT was located at the edge of the roadway. The vehicle fractured the first wood post and dislodged the concrete footing. The second concrete footing was also dislodged. The guiderail was bent at the buffer end connection to the guiderail. The vehicle was damaged extensively in the front and right side. The driver hit the windshield and was injured seriously.

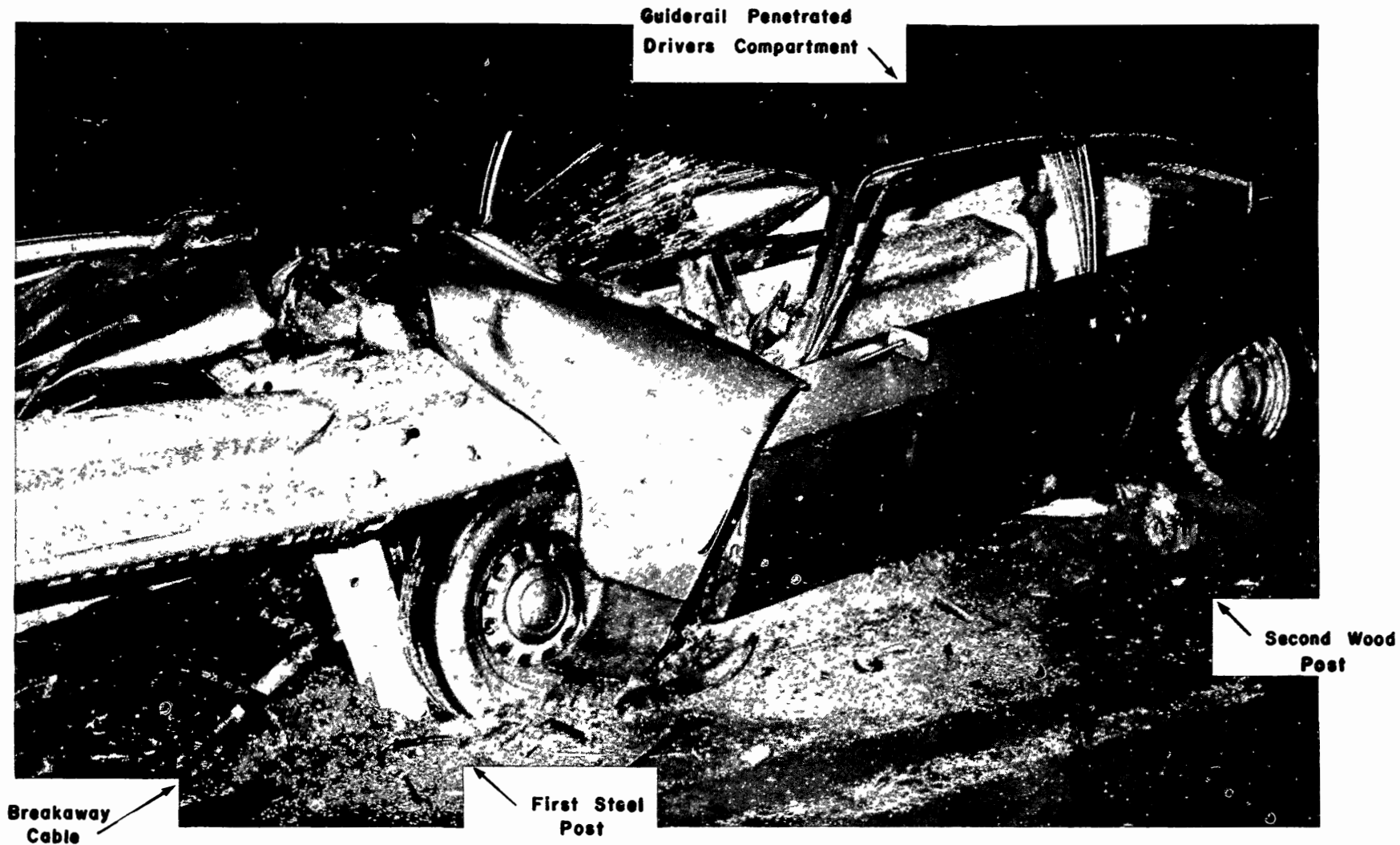

PICTURE 1
SPEARED CHEVROLET VEGA

Miscellaneous BCT Damage

Six minor accident cases of BCT impacts were reported to the Division of Research. A minor case is an impact that results in minor damage to the BCT. In the six cases, the undiaphragmed buffer end was compressed or deformed, probably by an automobile impact. The posts were not damaged in five cases. In one case, the post was split vertically through the retaining bolt but the post was not broken off. It was reported that several diaphragmed BCTs were damaged by mowers and snowplows. Two mower or snowplow damaged BCTs were inspected and it was concluded that the damage was substantially less than would have occurred with undiaphragmed BCTs. The undiaphragmed buffer ends will require replacement whereas the damage incurred by the diaphragmed buffer ends will not require their replacement.

Estimation of Recovery Area Behind BCT

The probable vehicle path for expected end hit penetration is shown in Figure 2, Page 13 from the Southwest Research Institute's crash tests. The SwRI test shows the vehicle passing 15 feet behind the guiderail after progressing 50 feet from the BCT. The Department's monitoring experience approximates the SwRI test result. However, actual measurements of vehicle penetration behind the guiderail by the Department was not practical because accident information was second hand and after the fact. The Department's monitoring efforts

only provided information on skid marks and tire tracks to determine the probable vehicle path.

The probable vehicle path closely approximates the clear distance defined by the length of need as determined by the Department's guiderail guidelines. The determination of the Department's length of need and probable vehicle path are shown in Figure 6. The probable path and recovery area are shown by the cross-hatched area and are defined by the diagonal line from the edge of the traveled way through the theoretical end of guiderail need to the obstruction and the line parallel to the above line running tangent to a six foot radius from the end of the BCT to the depth of the obstruction.

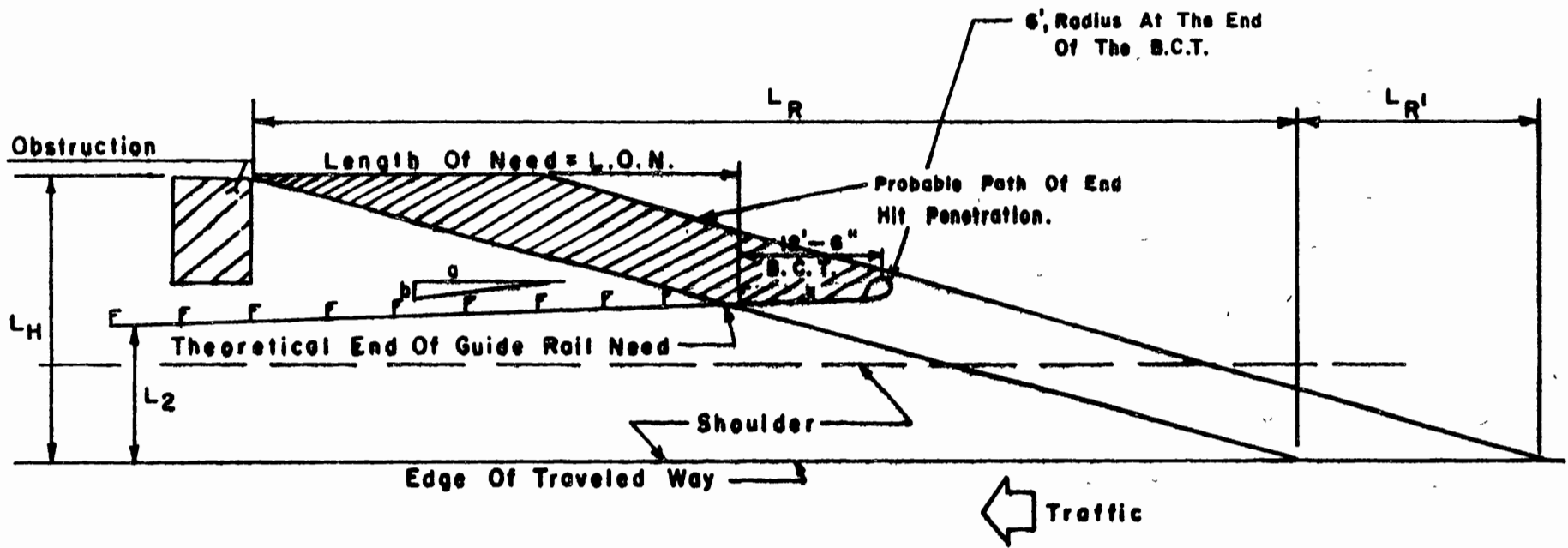

Figure 6 Recovery Area
 Probable Path Of End Hit Penetration

REFERENCES

1. Bronstad, M. E. and Miche, J. D., "Development and Crash Test Evaluation of Traffic Barrier Terminals, Phase II", Southwest Research Institute, Final Report, June 1975.
2. Bronstad, M. E. and Miche, J. D., "Guardrail Crash Test Evaluation; New Concepts and End Designs", National Cooperative Highway Research Program, Report 129, 1972.
3. Beaton, John L. and Field, Robert N., "Dynamic Full-Scale Tests of Median Barriers", HRB Bulletin 266, 1960.

APPENDIX A

**New Jersey Breakaway Cable Terminal
Accident Reporting Forms**

Appendix A-1

BREAKAWAY CABLE TERMINAL
ACCIDENT REPORTING FORM

DATE December 23, 1976 BCT # 22E2.0L1

ROUTE N.J. 57 and U.S. 22 LOCATION gore area (behind curb)

WEATHER clear ROAD CONDITIONS dry

BCT DESIGN 8"x 8" posts, diaphragmed buffer end

DAMAGE first post, rail, anchor cable in place, buffer not damaged

VEHICLE TYPE 1969 Volkswagon DAMAGE right front and under carriage

INJURIES The driver was seriously injured and taken to the hospital.

COMMENTS: The vehicle impacted the terminal at the buffer-end rail connection point striking the first post which broke away on a diagonal below and above the breakaway hole. The cable remained in place. This BCT is located behind a curb which probably caused the vehicle to vault impacting the BCT at the bumper level of the vehicle.

Vehicle was inoperative. Extensive damage to the undercarriage and front and right side occurred as the vehicle was contained by the bent rail.

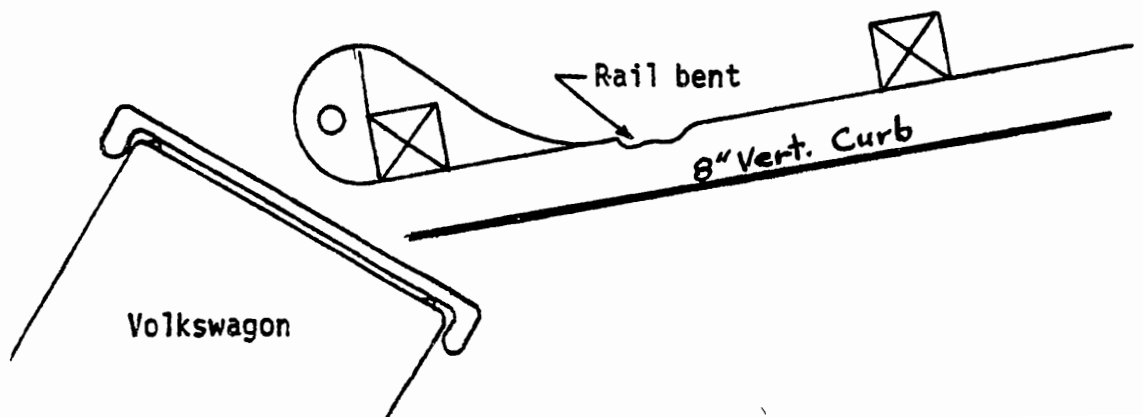

Appendix A-2

BREAKAWAY CABLE TERMINAL
ACCIDENT REPORTING FORM

DATE February 11, 1977 BCT # 541 W-TP-R1

ROUTE Co. Route 541 & Turnpike LOCATION along berm

WEATHER clear ROAD CONDITIONS icy

BCT DESIGN 6" x 8" posts, oversized buffer end

DAMAGE buffer end, broke first post but did not release cable

VEHICLE TYPE Chevrolet DAMAGE left front

INJURIES None

COMMENTS: Minor accident - The vehicle's left front impacted the BCT and glanced off as shown below. The berm was not graded and caused the vehicle to ride over the buffer end. County was notified to grade berm to obtain proper height for BCT.

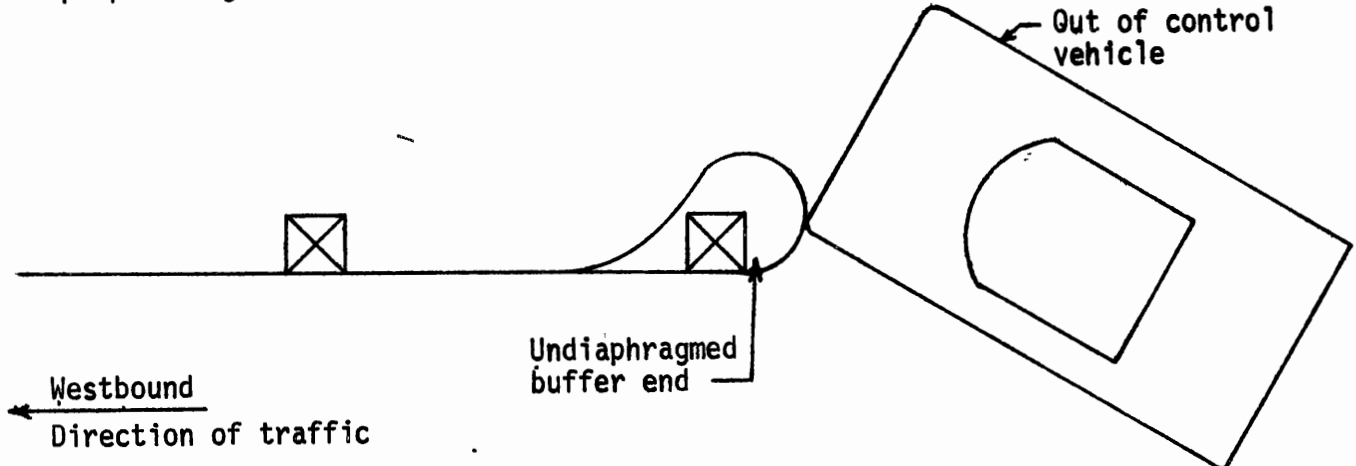

Probable Impact of BCT

Appendix A-3

BREAKAWAY CABLE TERMINAL
ACCIDENT REPORTING FORM

DATE June 19, 1977 BCT # 287 N 42.3 L1

ROUTE I-287 LOCATION Northbound - median

WEATHER Clear ROAD CONDITIONS Dry

BCT DESIGN 6" x 8" posts, no diaphragms

DAMAGE Buffer end was flattened and post was broken below breakaway
hole and at top of post

VEHICLE TYPE 1975 Pontiac DAMAGE Front - Radiator and Engine

INJURIES None

COMMENTS: (pictures of vehicle are not available)
Vehicle swung in this direction after impact

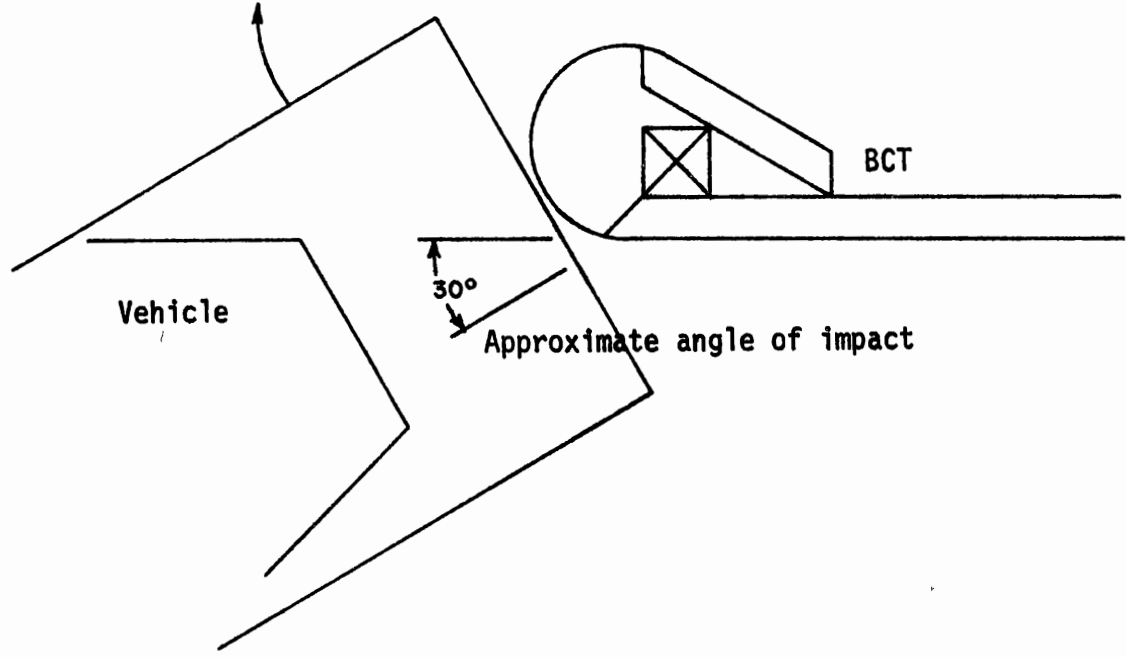

Appendix A-5

BREAKAWAY CABLE TERMINAL
ACCIDENT REPORTING FORM

DATE April 27, 1979 BCT # _____

ROUTE 22, Eastbound M.P. 407 LOCATION Greenbrook Twp.

WEATHER _____ ROAD CONDITIONS _____

BCT DESIGN Undiaphragmed buffer end, 6"x 8" wood posts

DAMAGE Broke first post, dislodged footing, crushed buffer end.

VEHICLE TYPE Rambler 1964 DAMAGE Front (hit pole)

INJURIES Serious injury to driver and passengers

COMMENTS:

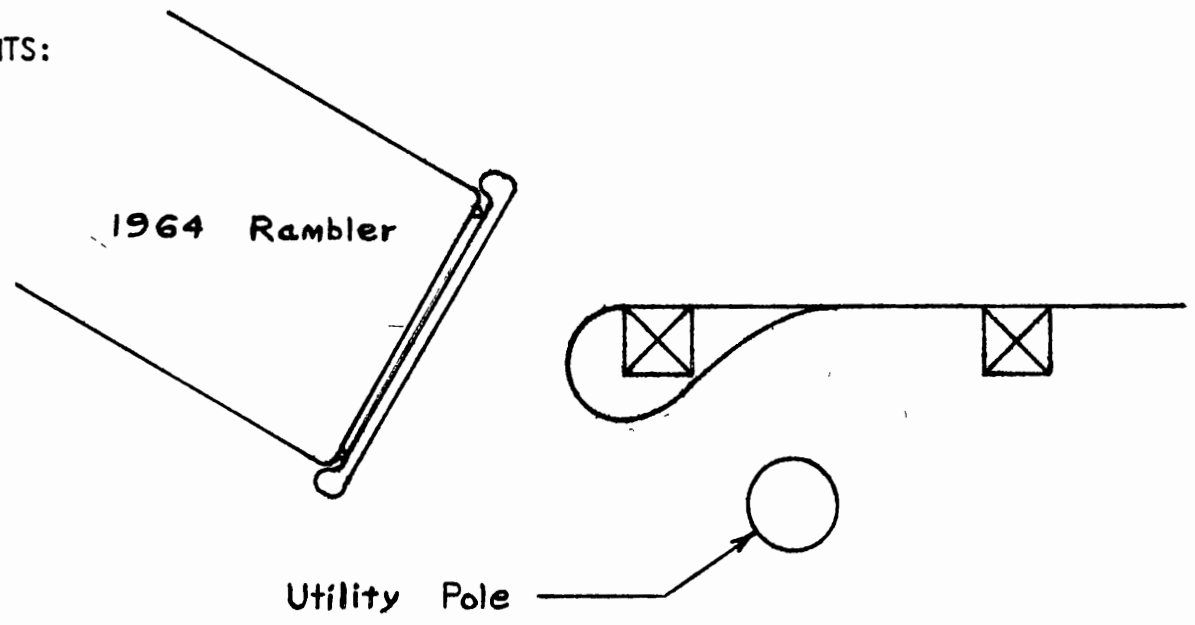

Appendix A-6

BREAKAWAY CABLE TERMINAL
ACCIDENT REPORTING FORM

DATE January 9, 1978 BCT # _____

ROUTE 57 Eastbound M.P. 14 LOCATION Anderson

WEATHER Snow ROAD CONDITIONS Snow covered

BCT DESIGN Diaphragm, 8"x 8" posts

DAMAGE First post split down the center, guard rail pulled away from second post.

VEHICLE TYPE Chevrolet 1972 DAMAGE Right front

INJURIES None

COMMENTS: Vehicle going eastbound impacted BCT on southside of road and swung across road onto private property on north side of road. (Foreman repaired BCT before Research personnel could take photos. Foreman pulled post out of concrete footing and replaced new post in old footing.)

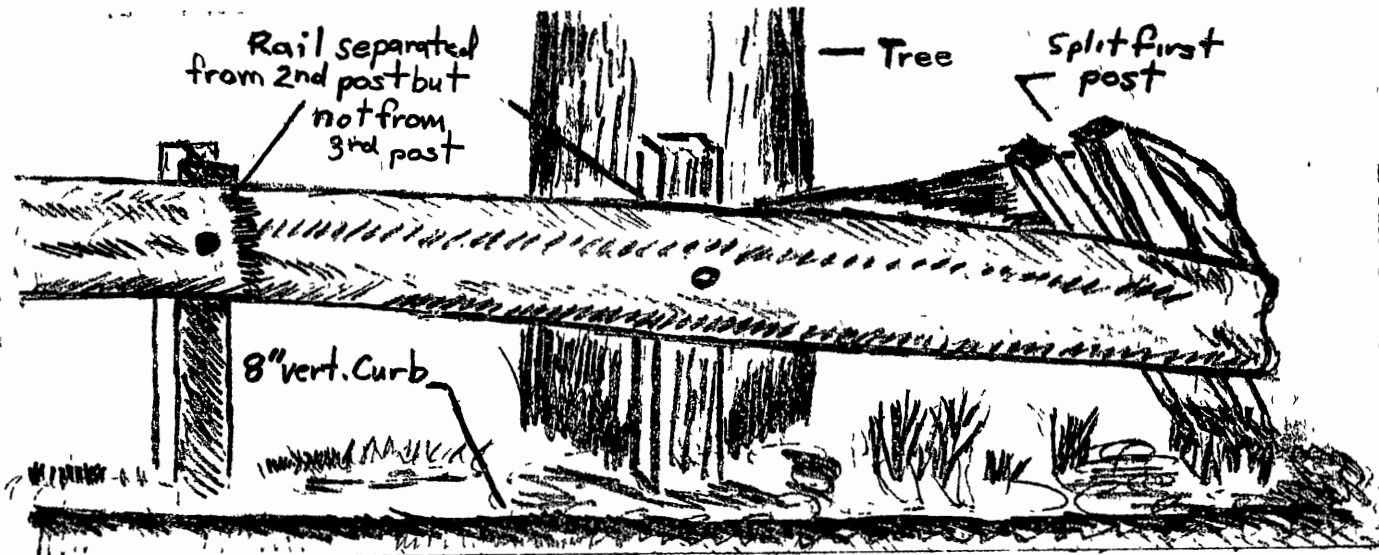

Appendix A-7

BREAKAWAY CABLE TERMINAL
ACCIDENT REPORTING FORM

DATE October 10, 1978 BCT # _____

ROUTE Rt. 22, W'bd. M.P. 34.2 LOCATION Bridgewater Twp.

WEATHER Clear ROAD CONDITIONS Clear and dry

BCT DESIGN Without diaphragm, 6" x 8" post

DAMAGE Unknown - Damaged BCT was removed before investigation

VEHICLE TYPE Ford (Van)

DAMAGE Speared "through grill of vehicle and out rear of driver's door"

INJURIES Driver - moderate injury - hospital

COMMENTS: Straight guiderail

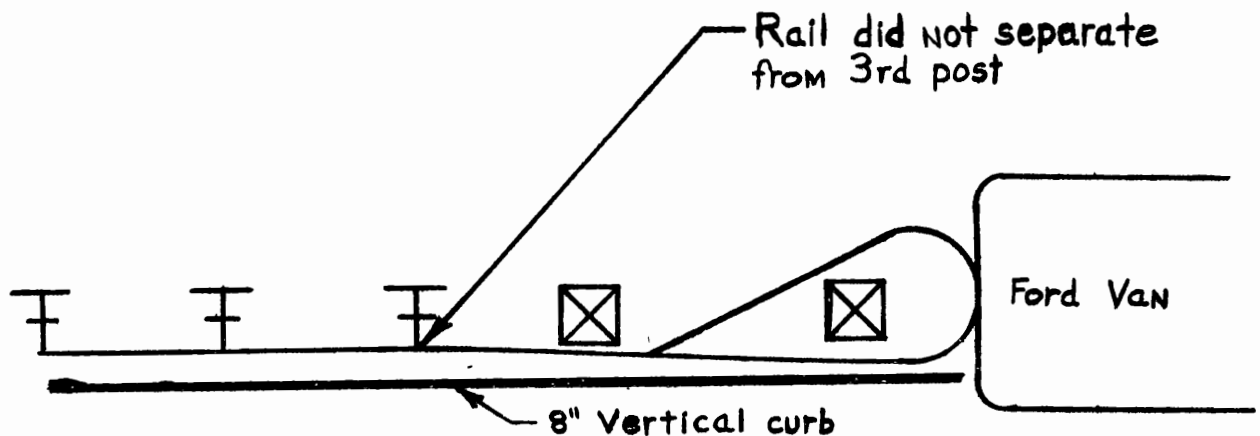

Appendix A-8

BREAKAWAY CABLE TERMINAL
ACCIDENT REPORTING FORM

DATE November 13, 1978 BCT # _____

ROUTE Rt. 94, N'bd. M.P. 32.2 LOCATION Hardyston Twp.

WEATHER Clear ROAD CONDITIONS Clear, dry

BCT DESIGN Without diaphragm, 6" x 8" posts

DAMAGE Broke off first two posts, crushed buffer end.

VEHICLE TYPE Dodge Dart DAMAGE Vehicle speared

INJURIES Head and chest

COMMENTS: There is a high probability that anyone in the passenger's seat would have been killed. Vehicle went under guiderail and BCT.

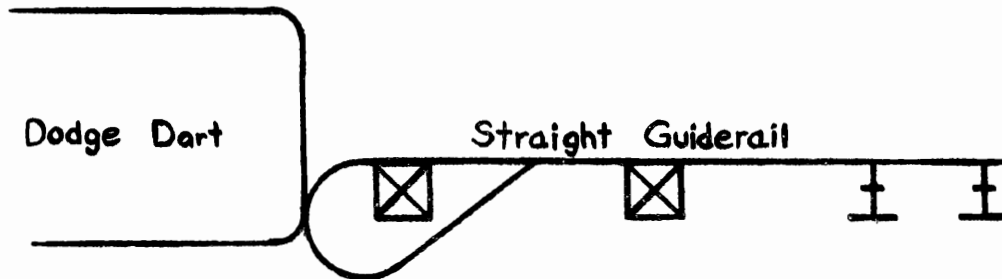

Appendix A-9

BREAKAWAY CABLE TERMINAL
ACCIDENT REPORTING FORM

DATE November 25, 1978 BCT # _____

ROUTE I-80, W.B. M.P. 11.5 LOCATION Hope Twp., Warren Co.

WEATHER Clear ROAD CONDITIONS Dry

BCT DESIGN Undiaphragmed buffer end, 6" x 8" post

DAMAGE Broke both wood posts, bent over three steel posts, broke footing on first post.

VEHICLE TYPE Chrysler 1970 DAMAGE Left front - Totalled

INJURIES Moderate injuries to driver

COMMENTS: The vehicle hit the BCT and rode 80 ft. on top. Vehicle overturned and came to rest on the four wheels.

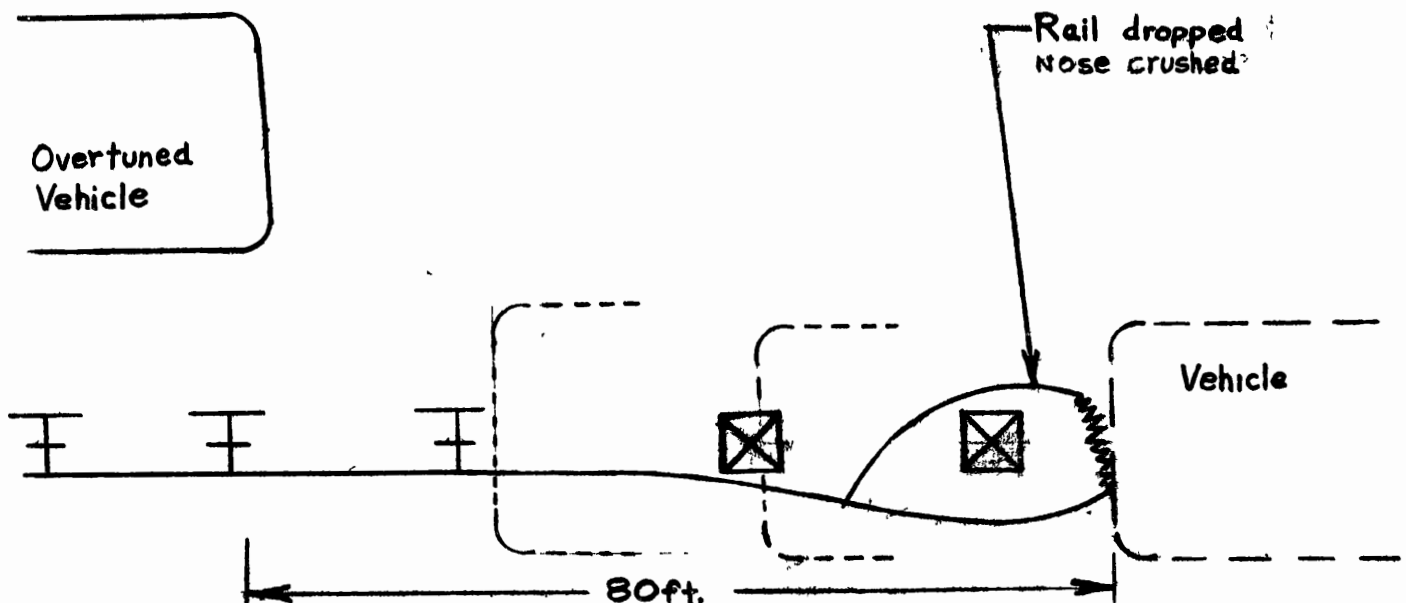

Appendix A-10

BREAKAWAY CABLE TERMINAL
ACCIDENT REPORTING FORM

DATE December 8, 1978 BCT # _____

ROUTE 94, N.B. M.P. 32.2 LOCATION Hardyston Twp. Sussex Co.

WEATHER Rain ROAD CONDITIONS Wet

BCT DESIGN Without diaphragm, 6" x 8" posts

DAMAGE Impact broke off the first two posts. Buffer end was crushed and

W-rail remained straight.

VEHICLE TYPE Chevy Vega DAMAGE Entire front half of vehicle

INJURIES Serious Injury to driver - taken to hospital

COMMENTS: (The investigators did not pursue an inquiry into the driver's precise condition. However, the driver was not killed.) The BCT speared the vehicle and penetrated the driver's compartment to the front seat back. Guiderail was installed parallel to roadway.

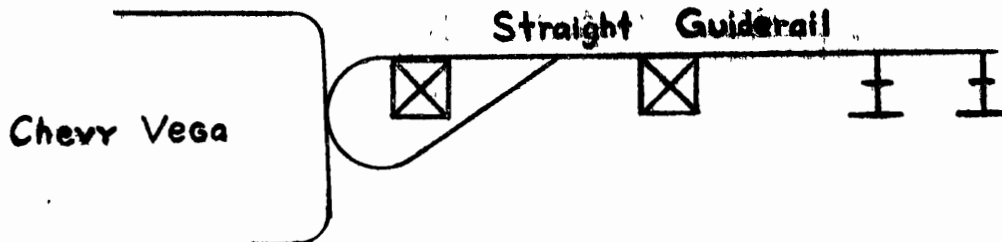

Appendix A-11

BREAKAWAY CABLE TERMINAL
ACCIDENT REPORTING FORM

DATE December 5, 1978 BCT # _____

ROUTE I-80 Westbound M.P. 18 LOCATION Allamuchy Twp. Warren Co.

WEATHER Clear ROAD CONDITIONS Dry

BCT DESIGN Undiaphragm buffer end, 6" x 8" posts

DAMAGE Did not break first post but pushed over post and footing and loosened second post footing.

VEHICLE TYPE Chevrolet 1977 DAMAGE Vehicle Totalled

INJURIES Driver and passenger - moderate injury

COMMENTS:

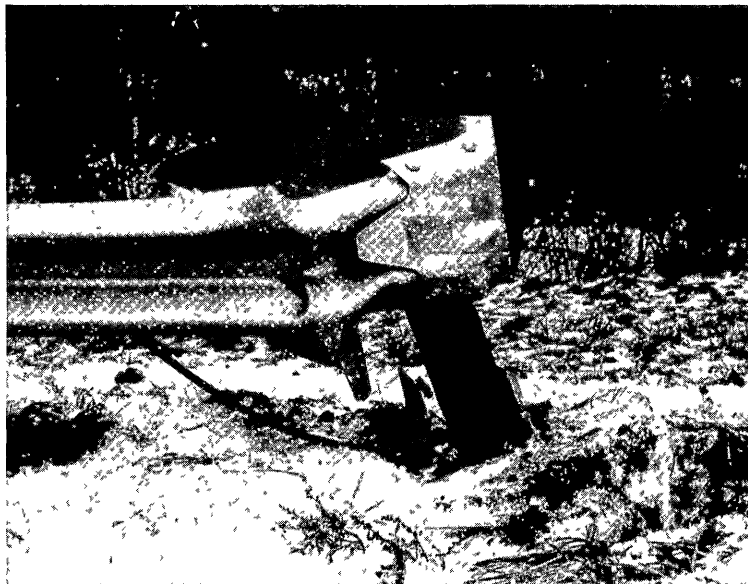

Pushed over
footing

Appendix A-12

BREAKAWAY CABLE TERMINAL
ACCIDENT REPORTING FORM

DATE December 13, 1978

BCT # _____

ROUTE 202-206 SB M.P. 272

LOCATION Bridgewater Township, Somerset

WEATHER Clear

ROAD CONDITIONS Dry

BCT DESIGN Undiaphragmed buffer end, 6"x8" posts

DAMAGE First post split (did not break at breakaway hole) and broke away.

Second post also broke. Rail bent behind buffer end.

VEHICLE TYPE Chevy Van

DAMAGE Front

INJURIES Head injuries

COMMENTS: The bulk of the vehicle (air conditioning unit, radiator and V-8 engine) prevented guiderail penetration of the vehicle.

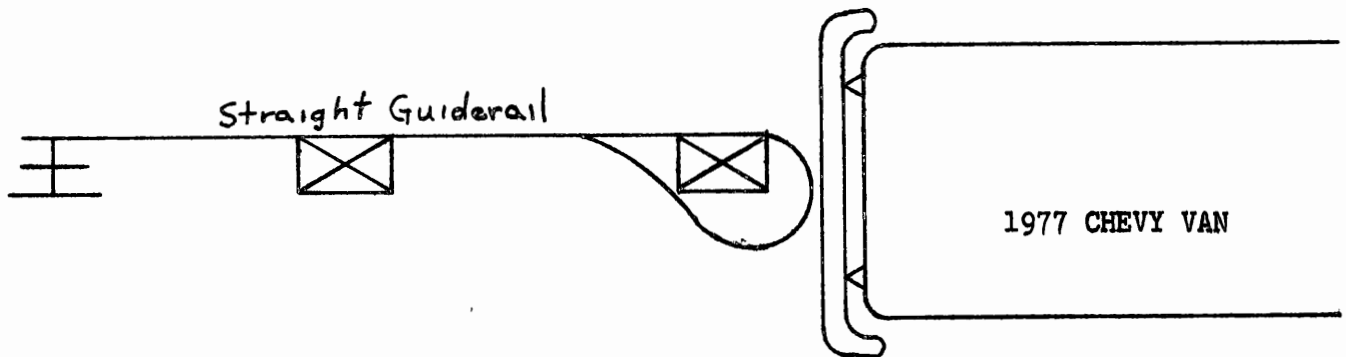

Appendix A-13

BREAKAWAY CABLE TERMINAL

ACCIDENT REPORTING FORM

DATE April 8, 1979 BCT # _____

ROUTE U.S. 206, Northbound M.P. 63.15 LOCATION Montgomery Township

WEATHER Clear ROAD CONDITIONS Dry

BCT DESIGN 6"x8" wood post, undiaphragmed buffer end

DAMAGE Broke first post, moved concrete footing (1st & 2nd post),

rail bent at junction of terminal connector & rail.

VEHICLE TYPE Plymouth Satellite DAMAGE Right front-penetration to firewall

INJURIES Driver - serious head injuries

COMMENTS:

