



State of New Jersey
THE PINELANDS COMMISSION
PO Box 359
NEW LISBON, NJ 08064
(609) 894-7300
www.nj.gov/pinelands



PHILIP D. MURPHY
Governor
TAHESHA L. WAY
Lt. Governor

General Information: Info@pinelands.nj.gov
Application Specific Information: AppInfo@pinelands.nj.gov

LAURA E. MATOS
Chair
SUSAN R. GROGAN
Executive Director

MEMORANDUM

To: CMP Policy & Implementation Committee

From: Gina A. Berg *gab*
Director, Land Use Programs

Date: April 18, 2024

Subject: April 26, 2024 Committee meeting

Enclosed please find the agenda for the Committee's upcoming meeting on Friday, April 26, 2024. We have also enclosed the following:

- The minutes from the Committee's February 23, 2024 meeting; and
- Executive Director's Report on Manchester Ordinance 24-02, Adopting the Redevelopment Plan for Block 62, Lots 30 and 31.01

The Committee meeting will be conducted in-person and via teleconference. Specific access information will be provided to all Committee members in a separate email. The public is invited to attend the meeting in-person or view and participate in the meeting through the following YouTube link:

www.youtube.com/c/PinelandsCommission



State of New Jersey
THE PINELANDS COMMISSION
PO Box 359
NEW LISBON, NJ 08064
(609) 894-7300
www.nj.gov/pinelands



PHILIP D. MURPHY
Governor
TAHESHA L. WAY
Lt. Governor

General Information: Info@pinelands.nj.gov
Application Specific Information: AppInfo@pinelands.nj.gov

LAURA E. MATOS
Chair
SUSAN R. GROGAN
Executive Director

CMP POLICY & IMPLEMENTATION COMMITTEE MEETING

April 26, 2024 – 9:30 a.m.

This meeting will be held in-person and virtually

Richard J. Sullivan Center for Environmental Policy and Education
Terrence D. Moore Conference Room
15C Springfield Road
New Lisbon, New Jersey

Watch the meeting on the Pinelands Commission YouTube channel:

www.youtube.com/c/PinelandsCommission

To Provide Public Comment, Please Dial: 1-929-205-6099 Meeting ID: 868 2262 3897

Agenda

1. Call to Order
2. Adoption of minutes from the February 23, 2024, CMP Policy & Implementation Committee meeting
3. Review of the Executive Director's report on Manchester Township Ordinance 24-02, Adopting the Redevelopment Plan for Block 62, Lots 30 and 31.01
4. Update on the Pinelands Preservation Summit & Pinelands Conservation Fund (PCF) Grant Round
5. PCF Stewardship Monitoring Report
6. Public Comment

CMP POLICY & IMPLEMENTATION COMMITTEE MEETING

This meeting was conducted both remotely and in-person.
The public could view/comment through Pinelands Commission YouTube link:

www.youtube.com/c/PinelandsCommission

Richard J. Sullivan Center
15C Springfield Rd
New Lisbon, New Jersey 08064
February 23, 2024 – 9:30 a.m.

MINUTES

Members in Attendance: Chair Laura E. Matos, Alan W. Avery, Jr., Theresa Lettman, Mark S. Lohbauer, Douglas Wallner

Members Absent: Jerome H. Irick

Other Commissioners Present: Jessica Rittler Sanchez (*as a non-member of the Committee, Commissioner Rittler Sanchez did not vote on any matter*)

Staff Present: Gina Berg, John Bunnell, Ernest Deman, April Field, Susan R. Grogan, Brad Lanute, Paul Leakan, Stacey P. Roth, and Steven Simone. Also in attendance was Alexis Franklin with the Governor's Authorities Unit.

1. Call to Order

Chair Matos called the meeting to order at 9:41 a.m.

2. Adoption of minutes from the November 29, 2023 CMP Policy & Implementation Committee Meeting

Commissioner Wallner moved the adoption of the November 29, 2023 meeting minutes. Commissioner Avery seconded the motion. Commissioners Avery, Lohbauer, Matos and Wallner voted to adopt the minutes. Commissioner Lettman abstained. The motion passed.

3. Adoption of minutes from the January 26, 2024 CMP Policy & Implementation Committee Meeting

Commissioner Lohbauer moved the adoption of the January 26, 2024 meeting minutes. Commissioner Lettman seconded the motion. The motion passed unanimously.

4. Presentation on Evesham Memorandum of Agreement (MOA) – Black Run Preserve Trails

Executive Director Susan R. Grogan introduced Kevin Rijs, the Community Development Director for Evesham Township, who then presented an overview of the project that will require a deviation Memorandum of Agreement from the Commission to proceed. Mr. Rijs introduced

other representatives of Evesham Township and the Pinelands Preservation Alliance who are involved in the project. He introduced Rich Kerr, Evesham Township Superintendent of Sports Turf and Open Space, Sean Kane-Holland, Pinelands Preservation Alliance, Carleton Montgomery, Pinelands Preservation Alliance, and Tim Staszewski, from Remington and Vernick (Township Engineer.)

Mr. Rijs presented a proposal for improving the trails at the Black Run Preserve so that they are compliant with the American Disabilities Act (ADA). He said the improvements would include approximately 4,000 linear feet of trail grading and stabilization with crushed stone, installation of a bridge to cross a former levee that has been breached, and creation of two ADA-compliant parking areas. (The presentation is available [here](#).) The project would also map and document trails and include improved signage to encourage the public to stay on and only use designated trails. He said that the existing 700+ acre municipal park draws people not only from Evesham Township but also regionally. He noted that the Township had received a stewardship grant to maintain the trails. He said that the Pinelands Preservation Alliance and the Friends of Black Run Preserve will be partners in implementing the improvements. He said extensive wetlands and wetlands buffers cover much of the park but particularly in the northwest section where the trail improvements are planned. Improvements to the trails that are located in wetlands or wetlands buffers would not be permitted under the standards of the Pinelands Comprehensive Management Plan (CMP) and for that reason the Township is seeking a deviation MOA from the Commission. He said much of the work will be completed by the Friends of the Black Run Preserve group on a volunteer basis.

Sean Kane-Holland reviewed the importance of the project to the for inclusivity and accessibility to people with disabilities in Evesham Township. He said more than 4,000 people with disabilities live in Evesham Township. He said the park will be improved with educational kiosks and signage. He showed examples of similar trails at county and state parks.

Kevin Rijs continued noting that offset opportunities exist onsite. Restoration of the Municipal Utilities infiltration basins and the creation of rain gardens are being considered. It is approximately eight acres.

ED Grogan asked to review the map where the proposed trail improvements would occur. She said the map shows that most of the trail is in wetlands and wetlands buffers. For that reason, the MOA process is necessary rather than a traditional Public Development Approval and will allow for grading and surfacing in wetlands, which is a deviation from CMP standards.

Carleton Montgomery, Executive Director of the Pinelands Preservation Alliance, discussed the choice of stone proposed for trail surfacing. He said the stone will not change the chemistry of the wetlands around the trail.

Tim Staszewski said that since the Township received the Commission's September 27, 2023 letter, it has made significant efforts to document trails and features that were permitted and those that were completed without application to the Commission, complete wetlands delineations, phase one environmental surveys and engineering plans for this project.

ED Grogan asked for confirmation that the entire parcel is preserved subject to Green Acres restrictions. Ms. Grogan noted that portions of the site were the subject of a previous MOA affecting the southern portion of the Preserve. She said the site has an extensive history with the Pinelands Commission.

Mr. Rijs said the entire park is preserved and that it has been on the municipal Recreation and Open Space Inventory.

Stacey Roth, Chief, Legal and Legislative Affairs asked for details on the planned length and width of the bridge. Mr. Staszewski said that the final length is to be determined because the bridge will reconnect a 30 foot by 8 foot section of former cranberry bog levee damaged by beaver activity. Additional study is needed to determine where the bridge footing can be installed, and that will determine the final length of the bridge.

Ms. Roth asked whether the proposed improvements would occur in phases.

Mr. Staszewski said that for the purposes of this MOA the Township is looking at all three park sections. The Township had originally focused on just the western section because it had received trail improvement grants from the NJDEP. However, after discussions with the Commission staff, they decided to include the entire site in this MOA proposal.

ED Grogan said that staff encouraged this comprehensive approach.

Ms. Roth asked for details on the anticipated offsets.

Mr. Rijs said the Township is considering restoration of the infiltration lagoons formerly used by the Municipal Utilities Authority. Rich Kerr added that the restoration would involve removal of invasive species and the plastic lagoon liners and revegetation with native species. Separately, the Evesham Township Environmental Commission is considering work in the Aerohaven area to revegetate and protect the area from future off-road vehicle damage.

Commissioner Wallner asked whether an environmental impact assessment has been completed for the approach to, and installation of, the bridge and which side of the approach to the bridge would be used for access by construction equipment. He said the trails in that section are narrow and in pristine environments.

Mr. Staszewski responded that construction access would likely come from the Tomlinson Mill side where the trails are wider and more suitable. He said the section of trail between Kettle Run and the proposed bridge is well-established, but they are proposing to resurface that section.

Commissioner Rittler Sanchez asked for clarification of any plans for the more southerly berm on the former cranberry bogs. She also asked whether the width of the trail approaching the bridge will accommodate turnaround for wheelchairs or other mobility devices.

Mr. Staszewski said there is no proposal to reconnect the more southerly berm because of existing use by wildlife.

Mr. Kane-Holland confirmed that the trails are wide enough to allow wheelchairs to turn around.

Commissioner Lohbauer asked what the total length of trails will be.

Mr. Staszewski said the total length is 4,620 linear feet.

Commissioner Lohbauer asked what the Township's timeline is for making the improvements.

Mr. Rijs said that the Township is moving forward as efficiently as possible, and that engineering and documentation of the existing trails will be completed fairly quickly.

ED Grogan reviewed the next steps in the MOA process. She said that if the P&I Committee is supportive, then this proposal would go to the full Commission, potentially in April. She said more work on stormwater management and other design details is needed and that will determine when the proposal would be ready for the full Commission. She said that the MOA public process includes holding a public hearing and takes time. She said that Ms. Roth will be working with the Township to finalize the details.

Commissioner Lohbauer made a motion to support the MOA proposal and send it to the full Commission. Commissioner Wallner seconded the motion. All voted in favor.

5. Discussion: Pinelands Conservation Fund Priorities and Acquisition Target Areas

Prior to the start of the presentation and discussion, Commissioner Avery said that he is the Chair of the Ocean County Natural Lands Trust, which may submit a project for funding through the Pinelands Conservation Fund (PCF). He recused himself from this discussion and left the meeting.

Gina Berg, Director of Land Use Programs, made a presentation (available [here](#)) on recommended changes to the criteria used to evaluate projects that are submitted to the Commission for acquisition funding through the PCF. She said that projects must be located in the acquisition target areas of either the Section 502 Fund areas or the Acquisition Target Areas identified by the Commission. She discussed prioritization of grassland habitats as directed by the source of funding from the South Jersey Transportation Authority Agreement. She reviewed other criteria including size of the project, connectivity with previously preserved lands and habitats, climate change impacts from flooding and fire hazard, and stewardship plans. She said that a new criterion was recommended this year to consider environmental justice communities with multiple environmental stressors. She said the goals of the recommended changes are to increase participation over recent years' PCF rounds, address environmental justice initiatives, continue to build successful stewardship, and to support climate mitigation goals identified by the Climate Committee by adding two expanded or new acquisition target areas. She said projects intended to preserve and maintain grassland habitats would receive additional points. She also noted that environmental justice communities and the stressors are identified by the New Jersey Department of Environmental Protection (NJDEP).

Ms. Berg discussed a suggested change to the funding award for projects that set aside funds for specific stewardship plans. The award could be increased to as much as 40% of acquisition costs for those projects with specific stewardship plans. The goal of this funding change is to potentially create a better grant proposal for a future America the Beautiful grant, but also to create incentives for acquisition and stewardship.

Ms. Berg reviewed the anticipated schedule for the PCF grants. She said staff are seeking authorization to use the recommended changes to the evaluation matrix and funding. She said staff is planning to hold the second annual Permanent Land Protection Summit in April when the new evaluation criteria, target areas, and funding structure will be rolled out. The Request for Projects would open in early May and the deadline for proposals would be in September. Project recommendations are intended to be brought to the Committee in October.

Commissioner Wallner asked if projects are limited to grassland acquisition. Ms. Berg said projects are not limited to grassland habitats, but that grassland projects will score higher using the suggested criteria.

Commissioner Rittler Sanchez asked how any potential allocation of Pinelands Development Credits (PDCs) are affected by land preservation. Ms. Berg said that the PDCs may be severed prior to preservation and that any PDCs that are not severed would be extinguished and no longer allocated to the preserved land. ED Grogan said where PDCs are severed prior to acquisition, the value of the land is reduced because the development rights are severed. She added that lands preserved through PDC severance typically are not submitted for acquisition funding through PCF because they are already preserved.

Commissioner Lettman asked if PDCs are required for development in the new acquisition target area in Pemberton Township's Regional Growth Area.

ED Grogan said that the area is residentially zoned but that PDCs are not mandatory for development in that area and noted that the assigned density is lower, and any future development is constrained by wetlands and wetlands buffers.

Commissioner Lohbauer commended the staff for objectively assessing the management area boundaries. He said incorporating the acquisition target areas helps achieve more of the Commission's goals.

Commissioner Rittler Sancez asked if the additional 7% funding is sufficient to address stewardship needs. Ms. Berg said that the additional funding is meant to be an incentive for preservation and stewardship and that it likely will not cover all costs of that stewardship plan. ED Grogan said that we are looking for other grant funding to help with stewardship.

Commissioner Lohbauer made a motion to approve the evaluation criteria, funding structure and added acquisition target areas. Commissioner Wallner seconded the motion. All voted in favor.

6. Public Comment

Carlton Montgomery, Pinelands Preservation Alliance, asked whether there is any natural grassland in the Pinelands Area. He asked if acquisition of a former soybean field that would be converted to grassland habitat would be considered for funding.

Ms. Berg said that those types of acquisition would be ideal for this evaluation matrix.

Emile DeVito of the New Jersey Conservation Foundation spoke about witnessing dump trucks hauling fill in to a site in Pemberton Township. He said the area and volume of fill was very large and included construction debris. He said trucks were coming from Essex and Union Counties. He notified the NJDEP and the Township. He said that the property representative indicated the fill was to support agricultural use of the property. He said the area had not been in agricultural use for decades. He said NJDEP staff from Solid Waste that visited the site did not have the authority to issue a stop work order. He said the Township representatives indicated that additional information had to be collected to determine whether a violation occurred. He said a notice of violation was issued on Friday but that the exact number of loads and volume of fill is unknown. He said that the Pinelands Commission needs enforcement authority to stop these types of violations.

Russell Juelg of the New Jersey Conservation Foundation and New Jersey Plant Partnership said he appealed to the Commission to update the list of threatened or endangered plant species. He encouraged the Commission to begin making science-based changes to the list and to adopt a method for incorporating future updates on a routine basis.

Jason Howell of the Pinelands Preservation Alliance said that the NJDEP Park Service has made progress on developing a road map for Wharton State Forest. He said the Commission resolution establishing a maximum baseline of roads in Wharton State Forest adopted in 2017 used USGS topographic maps as the basis for the baseline. He said it would be helpful if the Commission clarified the intent of the resolution regarding whether the roads on the topographic maps should be the only roads in Wharton.

Commissioner Lettman asked that a copy of the resolution be sent to her.

ED Grogan noted that the resolution is available on the Commission's website and staff can share a link to the resolution.

Commissioner Lohbauer said that public comments illustrate a serious problem with the Commission having to rely on other agencies to enforce the standards of the CMP. He said it would be appropriate to improve a line of communication with NJDEP to ensure action on violations such as the described dumping.

There being no other business, Commissioner Lohbauer moved to adjourn the meeting. Commissioner Lettman seconded the motion. All voted in favor. The meeting was adjourned at 11:08 a.m.

Certified as true and correct:



Gina A. Berg,
Director, Land Use Programs

Date: February 29, 2024



Township of Evesham

"Respecting Diversity, Preserving Dignity"

Mayor Jaclyn Veasy - Councilwoman Heather Cooper - Councilwoman Ginamarie Espinoza - Councilman Eddie Freeman, III - Councilwoman Patricia Hansen

984 Tuckerton Road • Marlton • NJ 08053 • 856-983-2900 • www.evesham-nj.org



CMP Policy and Implementation Committee Meeting 9:30 a.m Friday, February 23, 2024

1. Township of Evesham request for a potential Memorandum of Agreement (MOA) with the Pinelands Commission for the Municipal Park known as the Black Run Preserve (BRP).

2. BRP Municipal Park:
 - a. 700+ acre Municipal Park located in the southern section of the Township. As the entire park is listed on the municipal Recreation Open Space Inventory (ROSI) it is also subject to NJDEP Green Acres requirements in addition to Pinelands Commission regulations.

General Notes & Data Sources:
 This Geographic Information System (GIS) Recreation and Open Space Inventory (ROSI) Map is for demonstration purposes only, any use of this product with respect to accuracy and precision shall be the sole responsibility of the end user.
 The areas shown on this ROSI map are referenced, in part, from ground surveys, aerial surveys and recorded plans, and documents, and are to be used for approximate location purposes only.
 Water bodies: NJDEP NHD Dataset, 2002.
 NJDOT Roads: NJGN, 2017.
 Additional cadastral GIS mapping data, such as, waterways, roadways, etc. was obtained from the New Jersey Geographic Information Network (NJGIN), the New Jersey Department of Transportation (NJDOT), the New Jersey Department of Environmental Protection (NJDEP), the New Jersey Office of Information Technology (NJGIT), and the New Jersey Office of GIS (NJOGIS). The data was obtained and provided by the various New Jersey Departments at the New Jersey Geographic Information Network (NJGIN) <https://njgis-newjersey.opendata.arcgis.com>. This secondary product has not been verified by (NJGIN/NJGIT/NJOGIS/NJDOT/NJDEP) and is not state-authorized.
 All positions are based on the following:
 • NAD 83 (horizontal datum)
 • New Jersey State Plane Coordinate System
 • English units (feet)
 The geodetic accuracy and precision of the Geographic Information System (GIS) data contained in this mapping has not been developed nor verified by a professional licensed land surveyor and shall not be nor is intended to be used in matters requiring delineation and location of true ground horizontal and/or vertical controls.

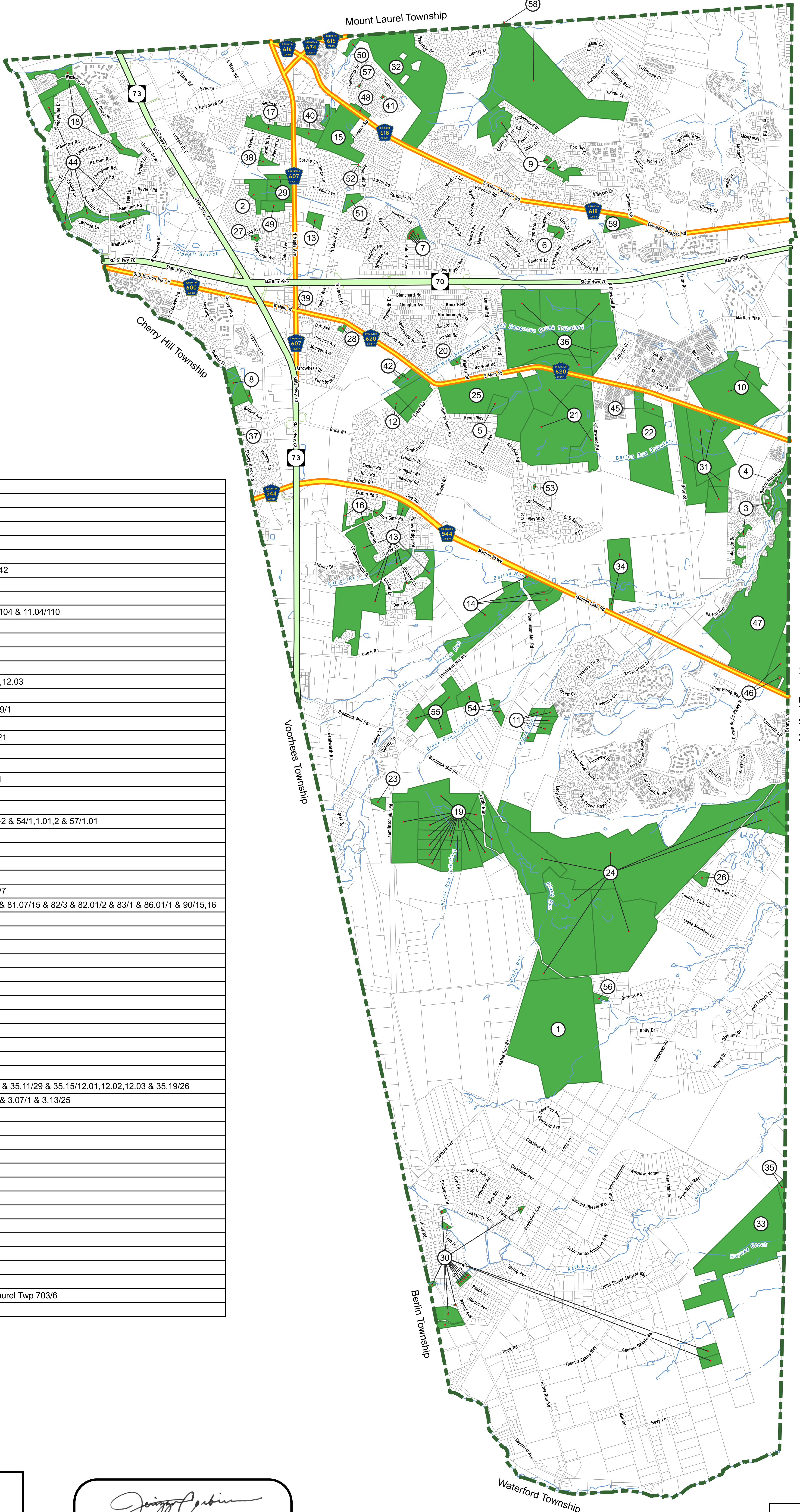
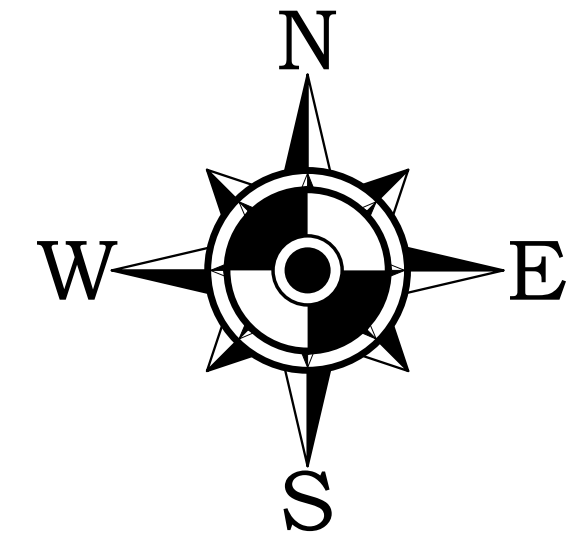

Map Key	Park Name	Block/Lot
1	Aerohaven	57/1
2	Baker Tract	20.15/6
3	Barton Run	44.17/1 & 44.19/57
4	Barton Run Lake	44.23/2.04
6	Heathrow Park	13.23/33
7	Cambridge Park	13.06/22,23,24,25,42
5	Brush Hollow	29/2
8	Carrefour	24.24/2.02,101
9	Country Farms	11.01/174 & 11.02/104 & 11.04/110
10	Croft Farm	31/8.07,9
11	Density Transfer	41/19,20,21,23,26
12	Downs Tract	26/10-11
13	Eisenhower Park	10/3.06
14	Evans Tract	40/2 & 41/12,12.01,12.03
15	Evesboro Downs	9/9.02
16	Glen Eayre	33.07/28,29 & 33.09/1
17	Greenlane Farms	7.04/41
18	Greentree Village	1.08/34,76 & 3.30/21
19	Hamilton Georgetown Road	47/2 & 48/4-16
20	Heritage	28.16/10
21	Indian Springs	29/3,3.01 & 29.12/1
22	Johnston Tract	30/2
23	Kenilworth	49/5
24	Kings Grant II	47/1 & 52/1 & 53/1-2 & 54/1,1.01,2 & 57/1.01
25	Koppenhaver Tract	29/1
26	Little Mill	54.04/22
27	London Square Park	20.11/25
28	Kain Memorial Park	4.11/5
29	Marlgreen Tract	6.17/11.01 & 20.15/7
30	Marlon Lakes	81.04/18-22,56,60 & 81.07/15 & 82/3 & 82.01/2 & 83/1 & 86.01/1 & 90/15,16
31	Memorial Park	44/5-8,11.01
32	Musulin	11/1
33	Pachoango	90/11
34	Project Heal Camp	38/6,16.01
35	Rancocas Watershed	90/9,9.01
36	Savich Tract	28.20/6-10
37	Tara	34.07/7
38	The Maples	6.15/1
39	Town Clock	4.05/17.05
40	Vineyards	9.01/124,190
41	Westbury Chase Park	8.06/18
42	Wiley Tract	26/8-9
43	Willow Ridge	35.03/4 & 35.09/31 & 35.11/29 & 35.15/12.01,12.02,12.03 & 35.19/26
44	Woodstream	1.01/2 & 3.01/1,44 & 3.07/1 & 3.13/25
45	Morrison Parcel	30/2.04
46	Barton Road	44.31/2-3
47	Vacant Land	44.26/110
48	Open Space	8.07/26
49	Open Space	20.07/1
50	Church Rd Farm	8.18/5
51	Park	13.64/13
52	Open Space	13.64/53
53	Vacant Land	38.02/1
54	Density Transfer	42/16,18,23
55	Density Transfer	46/1,3,4
56	Open Space	57/3.04
57	Tot Lot	8.02/30
58	Park (Formerly Beagle Club)	11.52/2 & Mount Laurel Twp 703/6
59	Open Space	18/3

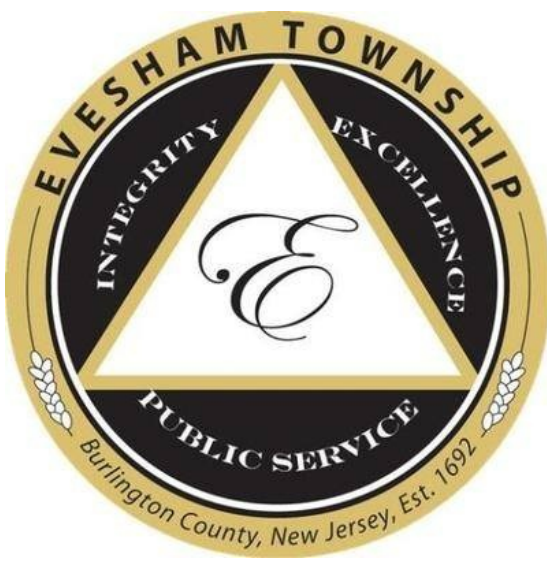

Recreational and Open Space
Evesham Township
 Burlington County New Jersey
 September 17th, 2021 Scale 1:1500
REMINGTON & VERNICK ENGINEERS
 2059 SPRINGDALE ROAD, CHERRY HILL, NJ 08003
 (856) 795-9595, FAX (856) 795-1882, RVE.COM
 Certificate of Authorization: 24 02 2800390
 Excellence • Innovation • Service

Jenizza Corbin
 DATE: 12/15/2022
JENIZZA CORBIN, PP
 NJ PROFESSIONAL PLANNER NO. 33L100681200

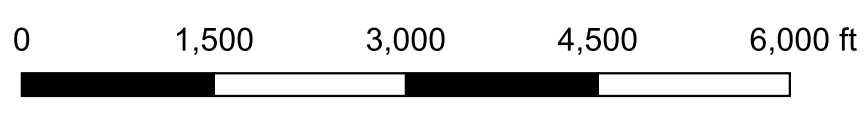

Legend

- Open Space/Park
- Parcel
- Stream
- Waterbody
- Municipal Boundary
- State Highway
- County Road
- Ramp

REVISIONS

NO.	DESCRIPTION	DATE	BY	CHK
1	Added Former Beagle Club & 387 Evesboro-Medford Road	Dec 7 th , 2022	ES	KZ
2				
3				
4				

REVISIONS				
NO.	DESCRIPTION	DATE	BY	CHK BY
1	TRAIL MAP	8/22/22	KT	
2	FORMATTING	9/21/22	LP	
3	FORMATTING	9/27/22	LP	
4	FORMATTING	12/7/2023	ES	
5	FORMATTING	1/4/2024	ES	

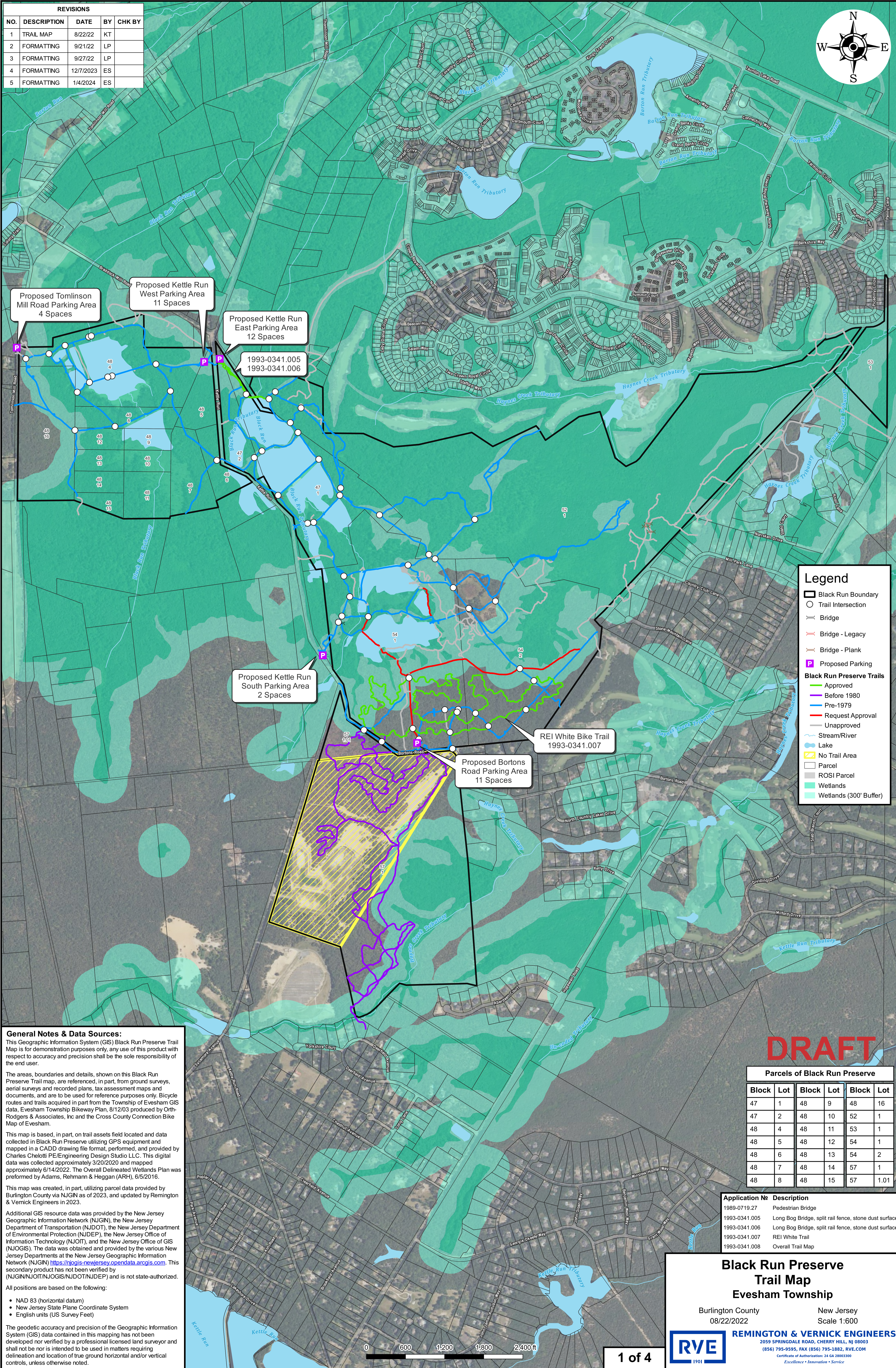
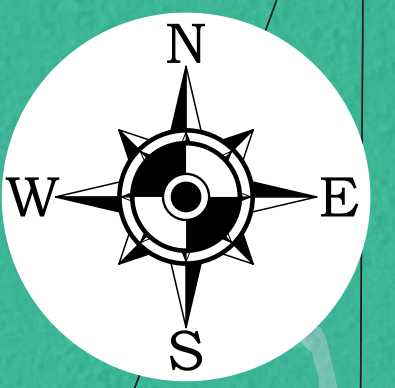

Proposed Tomlinson Mill Road Parking Area
4 Spaces

Proposed Kettle Run West Parking Area
11 Spaces

Proposed Kettle Run East Parking Area
12 Spaces

1993-0341.005
1993-0341.006

Proposed Kettle Run South Parking Area
2 Spaces

Proposed Bortons Road Parking Area
11 Spaces

REI White Bike Trail
1993-0341.007

Legend	
	Black Run Boundary
	Trail Intersection
	Bridge
	Bridge - Legacy
	Bridge - Plank
	Proposed Parking
Black Run Preserve Trails	
	Approved
	Before 1980
	Pre-1979
	Request Approval
	Unapproved
	Stream/River
	Lake
	No Trail Area
	Parcel
	ROSI Parcel
	Wetlands
	Wetlands (300' Buffer)

General Notes & Data Sources:
This Geographic Information System (GIS) Black Run Preserve Trail Map is for demonstration purposes only, any use of this product with respect to accuracy and precision shall be the sole responsibility of the end user.

The areas, boundaries and details, shown on this Black Run Preserve Trail map, are referenced, in part, from ground surveys, aerial surveys and recorded plans, tax assessment maps and documents, and are to be used for reference purposes only. Bicycle routes and trails acquired in part from the Township of Evesham GIS data, Evesham Township Bikeway Plan, 8/12/03 produced by Orth-Rodgers & Associates, Inc and the Cross County Connection Bike Map of Evesham.

This map is based, in part, on trail assets field located and data collected in Black Run Preserve utilizing GPS equipment and mapped in a CADD drawing file format, performed, and provided by Charles Chelotti PE/Engineering Design Studio LLC. This digital data was collected approximately 3/20/2020 and mapped approximately 6/14/2022. The Overall Delineated Wetlands Plan was performed by Adams, Rehmann & Heggan (ARH), 6/5/2016.

This map was created, in part, utilizing parcel data provided by Burlington County via NJGN as of 2023, and updated by Remington & Vernick Engineers in 2023.

Additional GIS resource data was provided by the New Jersey Geographic Information Network (NJGIN), the New Jersey Department of Transportation (NJDOT), the New Jersey Department of Environmental Protection (NJDEP), the New Jersey Office of Information Technology (NJGIT), and the New Jersey Office of GIS (NJOGIS). The data was obtained and provided by the various New Jersey Departments at the New Jersey Geographic Information Network (NJGIN) <https://njgis-newjersey.opendata.arcgis.com>. This secondary product has not been verified by (NJGIN/NJOT/NJOGIS/NJDOT/NJDEP) and is not state-authorized.

All positions are based on the following:

- NAD 83 (horizontal datum)
- New Jersey State Plane Coordinate System
- English units (US Survey Feet)

The geodetic accuracy and precision of the Geographic Information System (GIS) data contained in this mapping has not been developed nor verified by a professional licensed land surveyor and shall not be nor is intended to be used in matters requiring delineation and location of true ground horizontal and/or vertical controls, unless otherwise noted.

DRAFT

Parcels of Black Run Preserve					
Block	Lot	Block	Lot	Block	Lot
47	1	48	9	48	16
47	2	48	10	52	1
48	4	48	11	53	1
48	5	48	12	54	1
48	6	48	13	54	2
48	7	48	14	57	1
48	8	48	15	57	1.01

Application No	Description
1989-0719.27	Pedestrian Bridge
1993-0341.005	Long Bog Bridge, split rail fence, stone dust surface
1993-0341.006	Long Bog Bridge, split rail fence, stone dust surface
1993-0341.007	REI White Trail
1993-0341.008	Overall Trail Map

Black Run Preserve Trail Map
Evesham Township
Burlington County New Jersey
08/22/2022 Scale 1:600

REMINGTON & VERNICK ENGINEERS
2059 SPRINGDALE ROAD, CHERRY HILL, NJ 08003
(856) 795-9595, FAX (856) 795-1882, RVE.COM
Certificate of Authorization: 24 GA 28003300
Excellence • Innovation • Service

REVISIONS				
No	DESCRIPTION	DATE	BY	CHK BY
1	Added wetlands with buffer, fixed trail alignment and distance	2/5/2024	ES	
2	Added additional proposed features	2/15/2024	ES	
3				
4				

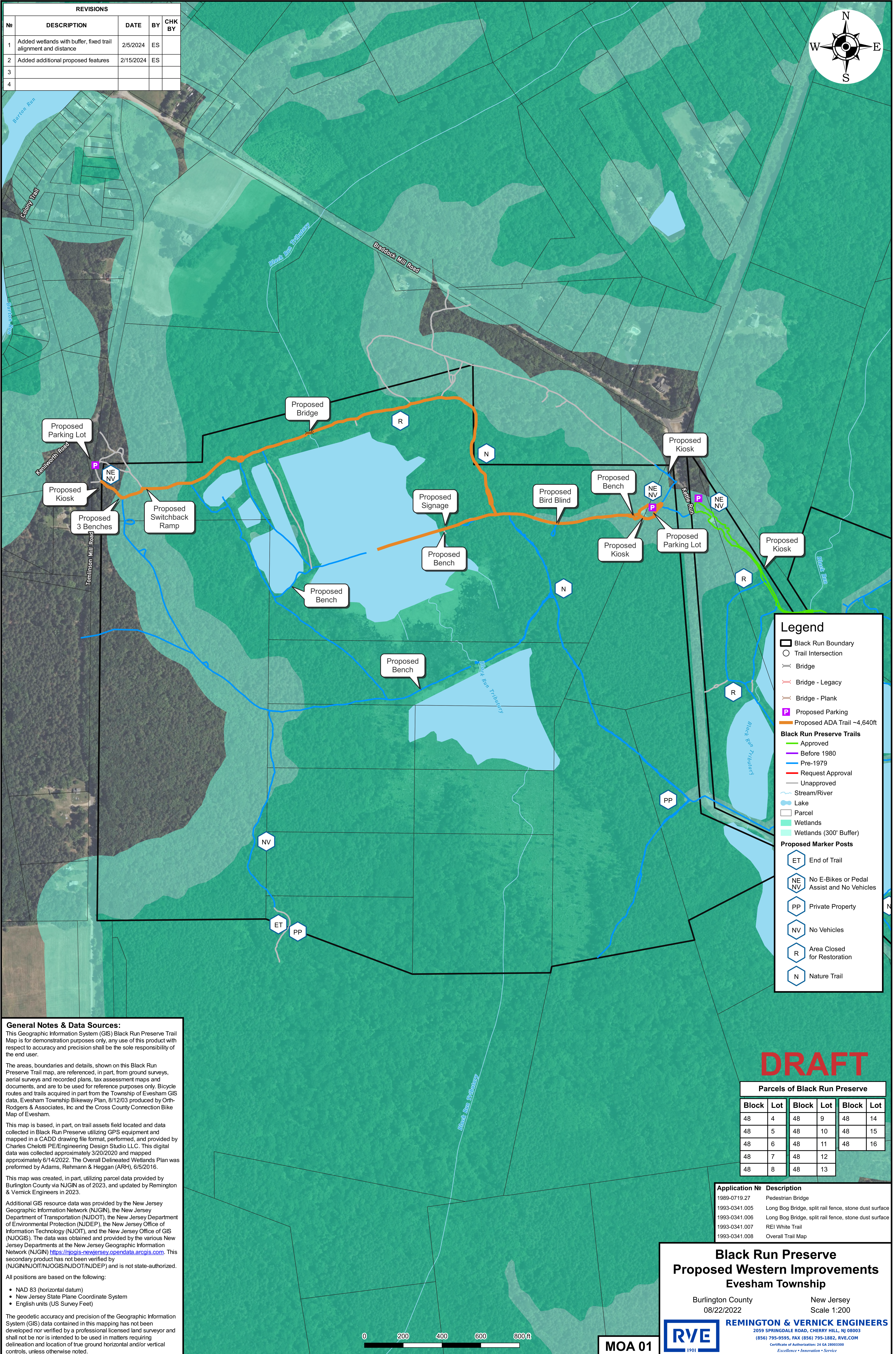
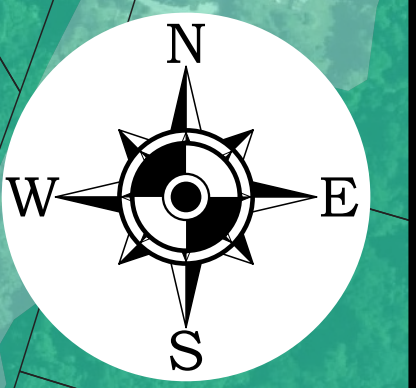

Legend

- Black Run Boundary
- Trail Intersection
- Bridge
- Bridge - Legacy
- Bridge - Plank
- Proposed Parking
- Proposed ADA Trail ~4,640ft
- Black Run Preserve Trails**
 - Approved
 - Before 1980
 - Pre-1979
 - Request Approval
 - Unapproved
- Stream/River
- Lake
- Parcel
- Wetlands
- Wetlands (300' Buffer)
- Proposed Marker Posts**
 - ET End of Trail
 - NE NV No E-Bikes or Pedal Assist and No Vehicles
 - PP Private Property
 - NV No Vehicles
 - R Area Closed for Restoration
 - N Nature Trail

General Notes & Data Sources:
 This Geographic Information System (GIS) Black Run Preserve Trail Map is for demonstration purposes only, any use of this product with respect to accuracy and precision shall be the sole responsibility of the end user.

The areas, boundaries and details, shown on this Black Run Preserve Trail map, are referenced, in part, from ground surveys, aerial surveys and recorded plans, tax assessment maps and documents, and are to be used for reference purposes only. Bicycle routes and trails acquired in part from the Township of Evesham GIS data, Evesham Township Bikeway Plan, 8/12/03 produced by Orth-Rodgers & Associates, Inc and the Cross County Connection Bike Map of Evesham.

This map is based, in part, on trail assets field located and data collected in Black Run Preserve utilizing GPS equipment and mapped in a CADD drawing file format, performed, and provided by Charles Chelotti PE/Engineering Design Studio LLC. This digital data was collected approximately 3/20/2020 and mapped approximately 6/14/2022. The Overall Delineated Wetlands Plan was performed by Adams, Rehmann & Heggan (ARH), 6/5/2016.

This map was created, in part, utilizing parcel data provided by Burlington County via NJGN as of 2023, and updated by Remington & Verrick Engineers in 2023.

Additional GIS resource data was provided by the New Jersey Geographic Information Network (NJGN), the New Jersey Department of Transportation (NJDOT), the New Jersey Department of Environmental Protection (NJDEP), the New Jersey Office of Information Technology (NJOT), and the New Jersey Office of GIS (NJOGIS). The data was obtained and provided by the various New Jersey Departments at the New Jersey Geographic Information Network (NJGN) <https://njgis-newjersey.opendata.arcgis.com>. This secondary product has not been verified by (NJGIN/NJOT/NJOGIS/NJDOT/NJDEP) and is not state-authorized.

All positions are based on the following:

- NAD 83 (horizontal datum)
- New Jersey State Plane Coordinate System
- English units (US Survey Feet)

The geodetic accuracy and precision of the Geographic Information System (GIS) data contained in this mapping has not been developed nor verified by a professional licensed land surveyor and shall not be nor is intended to be used in matters requiring delineation and location of true ground horizontal and/or vertical controls, unless otherwise noted.

DRAFT

Parcels of Black Run Preserve

Block	Lot	Block	Lot	Block	Lot
48	4	48	9	48	14
48	5	48	10	48	15
48	6	48	11	48	16
48	7	48	12		
48	8	48	13		

Application # Description

1989-0719.27	Pedestrian Bridge
1993-0341.005	Long Bog Bridge, split rail fence, stone dust surface
1993-0341.006	Long Bog Bridge, split rail fence, stone dust surface
1993-0341.007	REI White Trail
1993-0341.008	Overall Trail Map

**Black Run Preserve
 Proposed Western Improvements
 Evesham Township**

Burlington County New Jersey
 08/22/2022 Scale 1:200

REMINGTON & VERRICK ENGINEERS
 2059 SPRINGDALE ROAD, CHERRY HILL, NJ 08003
 (856) 795-9595, FAX (856) 795-1882, RVE.COM
 Certificate of Authorization: 24 GA 28003300
 Excellence • Innovation • Service

RVE 1901

MOA 01

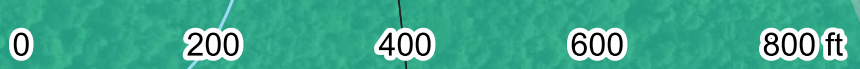

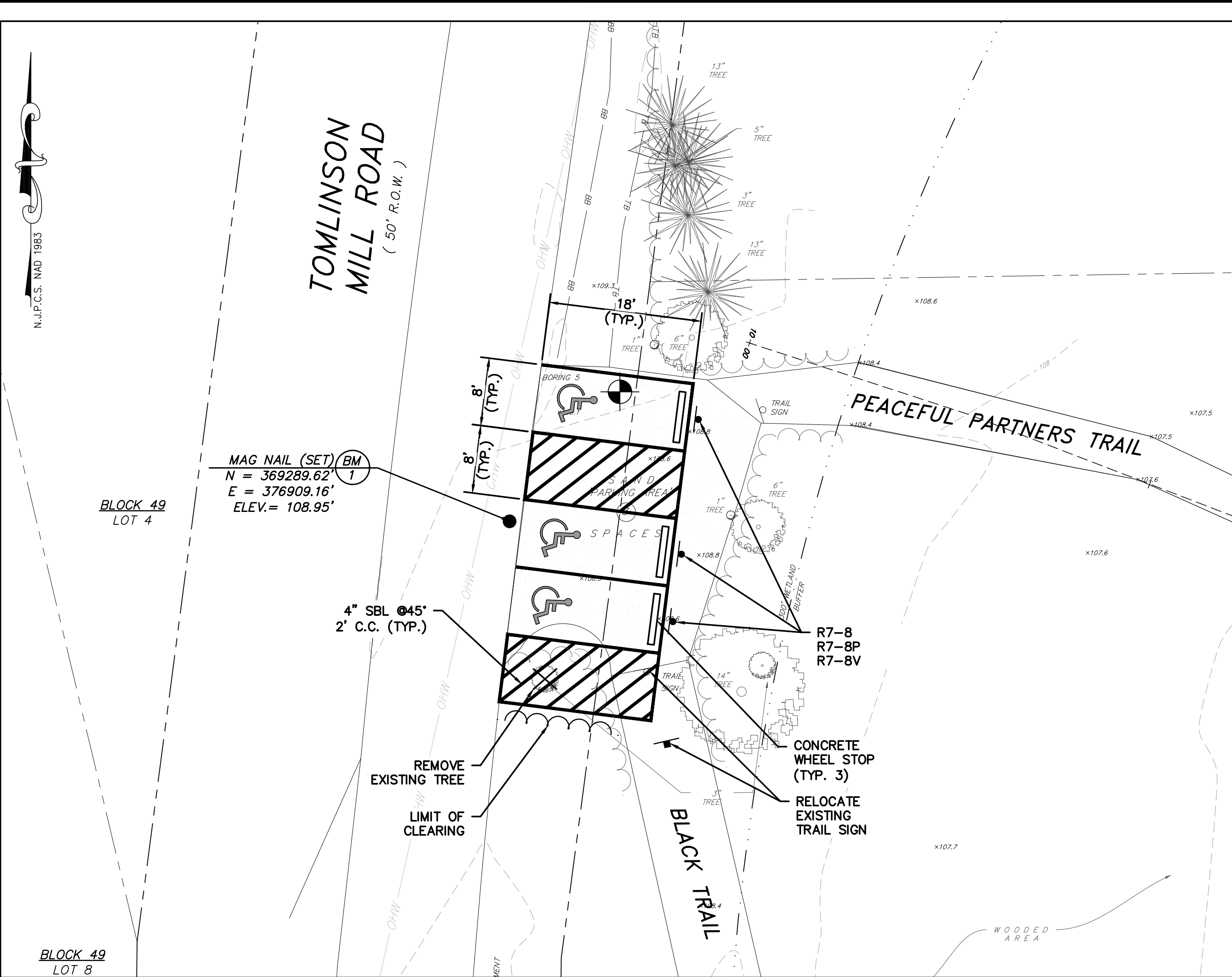

GENERAL NOTES

- CONTRACTOR SHALL VERIFY ALL DIMENSIONS AND EXISTING CONDITIONS IN THE FIELD PRIOR TO THE START OF THE CONSTRUCTION, ANY ERRORS OR DISCREPANCIES SHALL BE BROUGHT TO THE ATTENTION OF THE ENGINEER IMMEDIATELY.
- LOCATION OF EXISTING UTILITIES ARE APPROXIMATE AND MUST BE VERIFIED IN THE FIELD PRIOR TO THE START OF CONSTRUCTION.
- THE CONTRACTOR SHALL USE EXCAVATED MATERIALS FOR BACKFILL UNLESS OTHERWISE DIRECTED BY THE ENGINEER.
- ALL PAVED AND CONCRETE AREAS DISTRIBUTED DURING CONSTRUCTION SHALL BE RESTORED TO EXISTING CONDITION AT LEAST EQUAL TO THAT WHICH EXISTED PRIOR TO THE START OF CONSTRUCTION.
- ALL GRASSED OR WOODED AREAS DISTRIBUTED DURING CONSTRUCTION SHALL BE TOPSOILED AND SEEDED.
- ALL FILL SHALL BE PLACED IN 12" LAYERS AND THOROUGHLY COMPACTED TO THE SATISFACTION OF THE ENGINEER. IF BORROW FILL IS REQUIRED, IT SHALL BE SUBJECT TO THE APPROVAL OF THE ENGINEER.
- THE CONTRACTOR SHALL BE RESPONSIBLE FOR THE LOCATION AND PRESERVATION OF THE UNDERGROUND AND SURFACE UTILITIES AND STRUCTURES AT OR ADJACENT TO THE SITE OF CONSTRUCTION AND IT SHALL BE AT HIS OWN EXPENSE TO REPAIR OR REPLACE ANYTHING THAT HE DAMAGES.
- ALL CONSTRUCTION DETAILS NOT SHOWN SHALL BE IN ACCORDANCE WITH N.J.D.O.T. STANDARDS AS DETAILED IN:
 - "STANDARD ROADWAY CONSTRUCTION/TRAFFIC CONTROL/BRIDGE CONSTRUCTION DETAILS, 2016."
 - "ELECTRICAL BUREAU STANDARD DETAILS: 2007,"
 INCLUDING ALL APPLICABLE BASELINE DOCUMENT CHANGES AND APPENDICES. THESE DETAILS MAY BE PURCHASED THROUGH THE N.J.D.O.T. PLANS AND SPECIFICATION CENTER AT:
 1035 PARKWAY AVENUE,
 TRENTON, NEW JERSEY
 08625-0600
 (TELEPHONE: 1-609-530-2098)
- SEPARATE PAYMENT WILL NOT BE MADE FOR SAW CUTTING OF ANY KIND, BUT THE COST SHALL BE INCLUDED IN THE VARIOUS ITEMS OF THE PROPOSAL.
- PAYMENT FOR JOINT MATERIAL FOR ALL CONCRETE WORK WILL NOT BE MEASURED BUT SHALL BE INCLUDED IN THE VARIOUS ITEMS OF THE PROPOSAL.
- TRAFFIC CONTROL SHALL BE IN ACCORDANCE WITH THE LATEST DETAILS TCD-1 THROUGH TCD-5.
- THE CONTRACTOR SHALL BE RESPONSIBLE FOR ALL UTILITY MARK OUTS AND COMPLIANCE WITH ALL FEDERAL, STATE AND LOCAL CODES AND REGULATIONS.
- THE CONTRACTOR IS RESPONSIBLE FOR OBTAINING ALL NECESSARY PERMITS FOR CONSTRUCTION FROM THE APPROPRIATE GOVERNMENT AGENCIES, WHERE APPLICABLE.
- THE CONTRACTOR SHALL ADJUST THE POSITION OF ANY AND ALL PROPOSED STRUCTURES AND PLANTINGS TO ACCOMMODATE EXISTING UTILITIES AND BUILDING FEATURES. THE LANDSCAPE ARCHITECT SHALL BE CONTACTED WITH ANY QUESTIONS AND/OR CONCERNS.
- THE CONTRACTOR SHALL COORDINATE BENCH TYPE, PURCHASE AND INSTALLATION WITH OWNER.
- THE CONTRACTOR IS RESPONSIBLE FOR THE REMOVAL OF ALL DEBRIS AND EXCESS MATERIALS FROM THE JOB SITE.

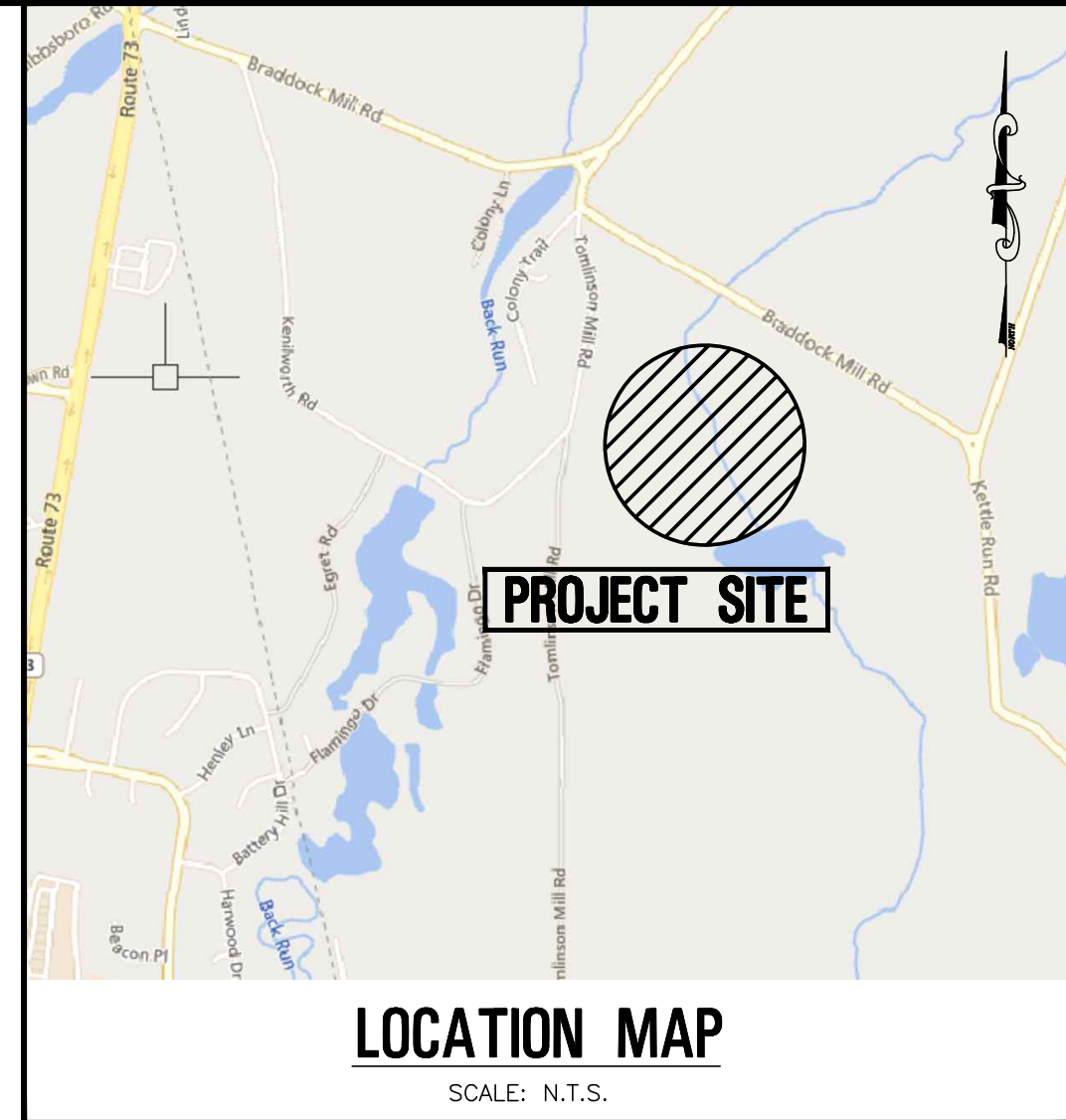

RVE
1901
REMINGTON & VERNICK ENGINEERS
2059 SPRINGDALE ROAD
CHERRY HILL, NJ 08003
(856) 795-9595, FAX (856) 795-1882
WEB ADDRESS : RVE.COM
Certification of Authorization: 24 GA 28003300
Excellence • Innovation • Service

DATE: _____
TIMOTHY R. STASZEWSKI
 NJ PROFESSIONAL ENGINEER LIC. NO. 47542

SURVEY NOTES & REFERENCES:

- THE HORIZONTAL DATUM IS BASED ON THE NEW JERSEY STATE PLANE COORDINATE SYSTEM (NAD-1983) AND THE VERTICAL DATUM IS BASED ON NAVD-1988 - 2012A ADJ. (ADD 1.17 FEET TO THESE ELEVATIONS TO CONVERT TO NGVD-1929 DATUM)
- PROPERTY AND RIGHT-OF-WAY LINES SHOWN ON THESE PLANS ARE APPROXIMATE LOCATIONS BASED ON THE CURRENT TAX MAPS OF THE TOWNSHIP OF CHERRY HILL, CAMDEN COUNTY, NEW JERSEY. PROPERTY AND RIGHT-OF-WAY LINES ARE SHOWN FOR GRAPHICAL INFORMATION ONLY AND HAVE NOT BEEN FIELD VERIFIED.
- EXISTING TOPOGRAPHIC CONDITIONS WERE SURVEYED BY REMINGTON & VERNICK ENGINEERS UNDER THE SUPERVISION OF CHARLES E. ADAMSON, N.J.P.L.S. LICENSE NO. 42627. THE SURVEY WORK WAS COMPLETED ON AUGUST 24 & SEPTEMBER 12, 2023. ADDITIONAL TOPOGRAPHIC SURVEY COMPLETED JANUARY 11, 2024.
- WETLAND DELINEATION & LOCATION PERFORMED BY REMINGTON & VERNICK ENGINEERS ON AUGUST 15, 2023.
- THIS PLAN AND SURVEY DOES NOT CERTIFY TO THE LOCATION, BOTH HORIZONTAL AND VERTICAL, OF ANY UNDERGROUND UTILITY OR STRUCTURE THAT WAS NOT EXPOSED FOR DIRECT MEASUREMENT.

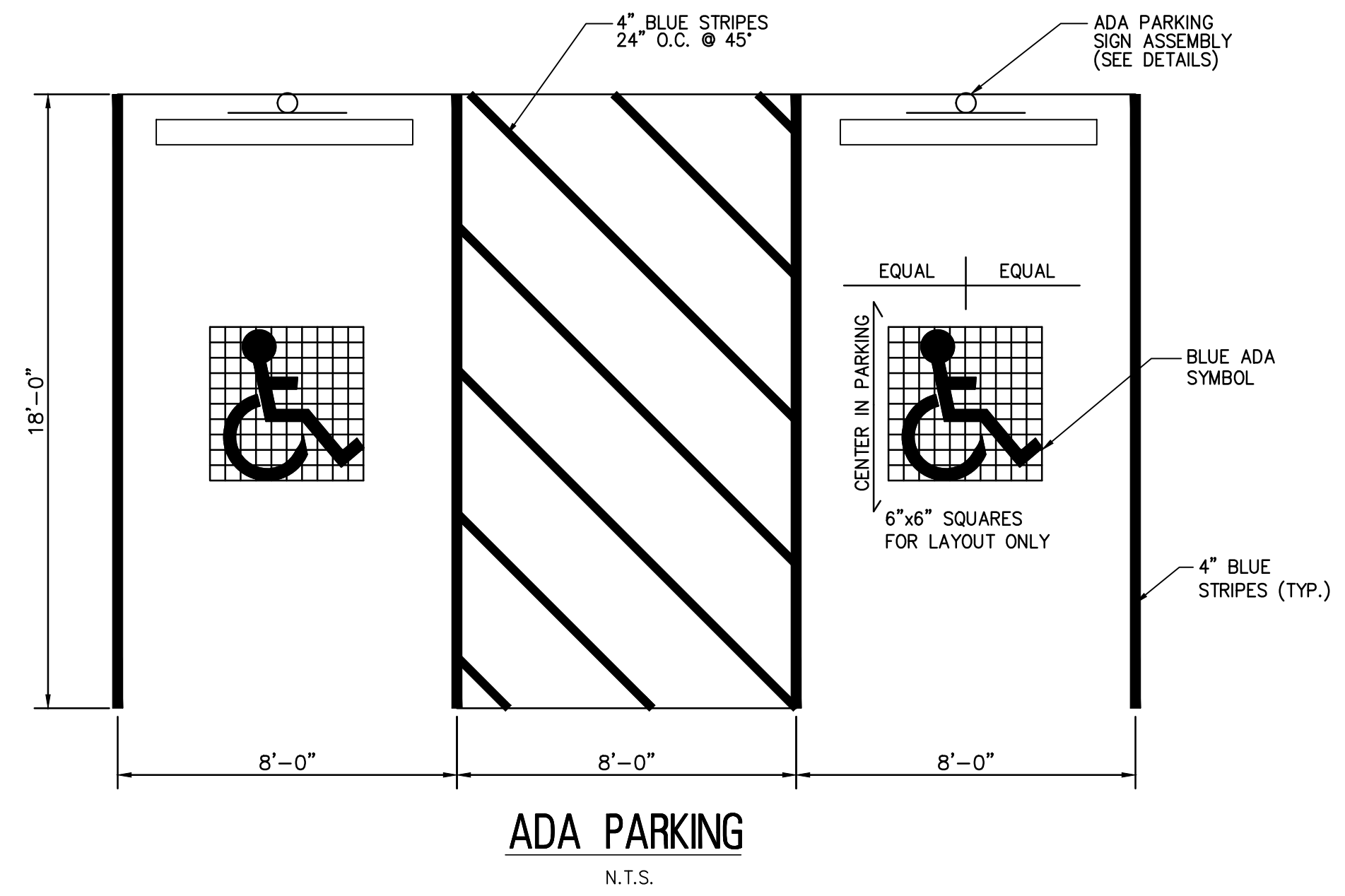
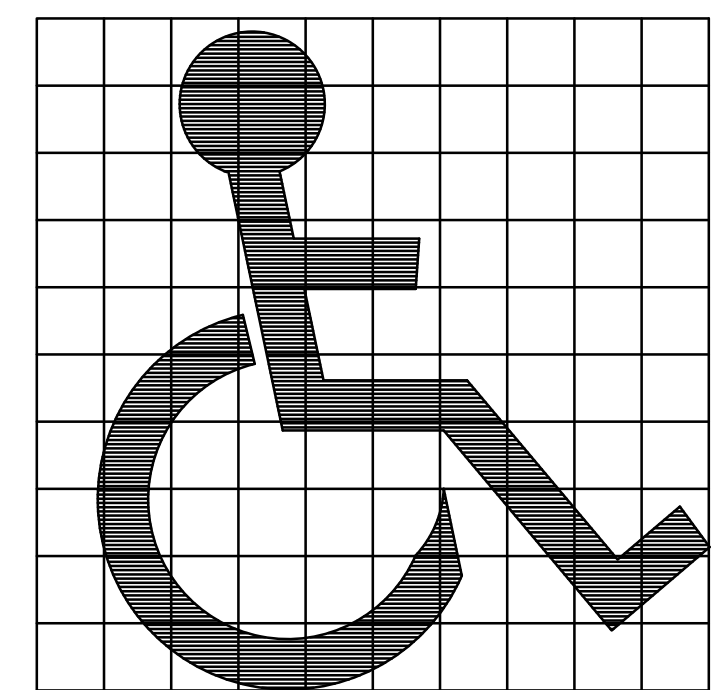
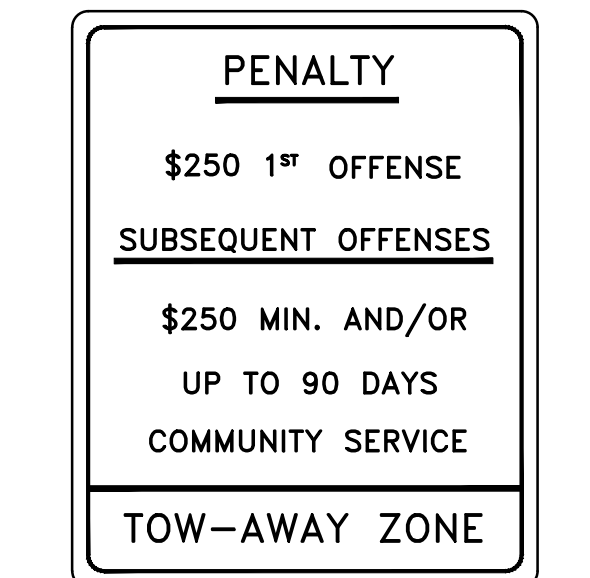
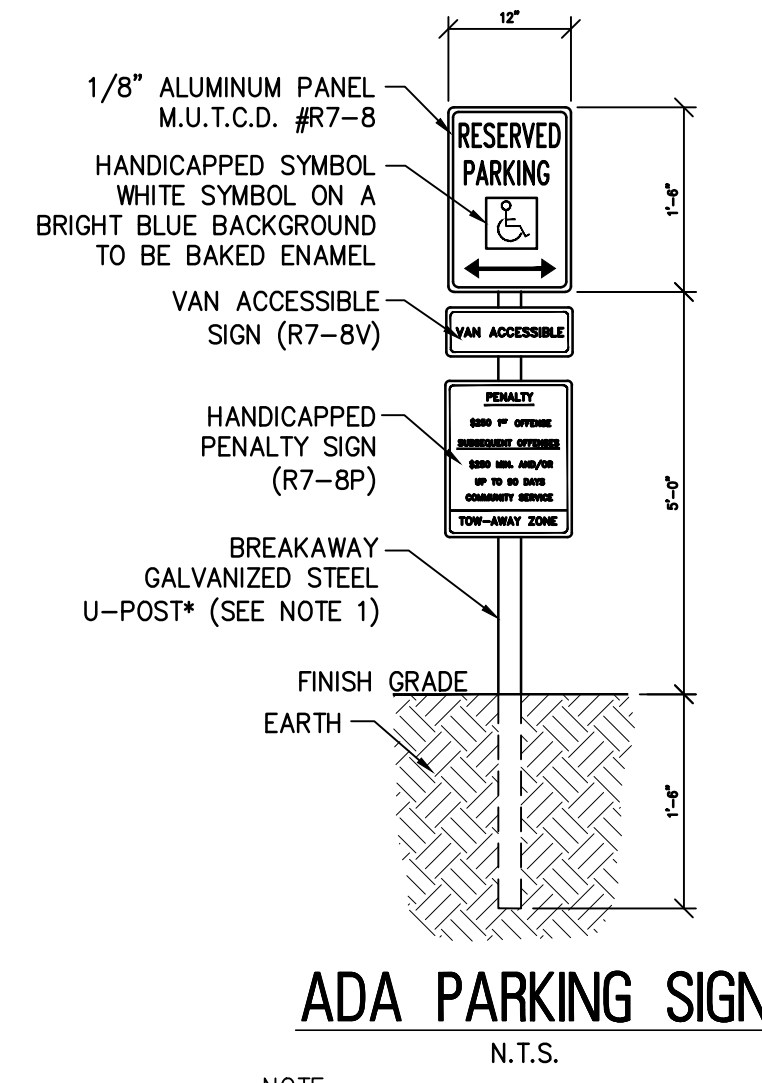
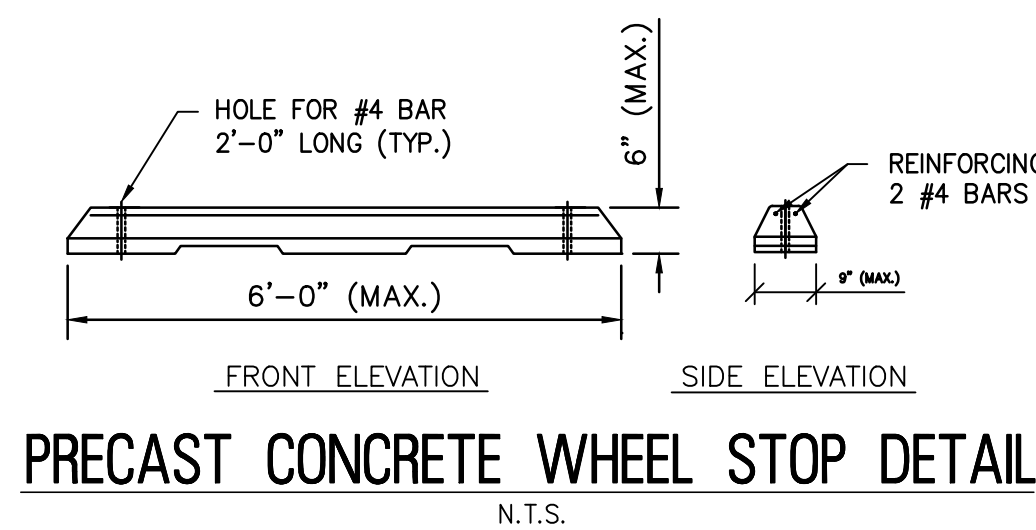
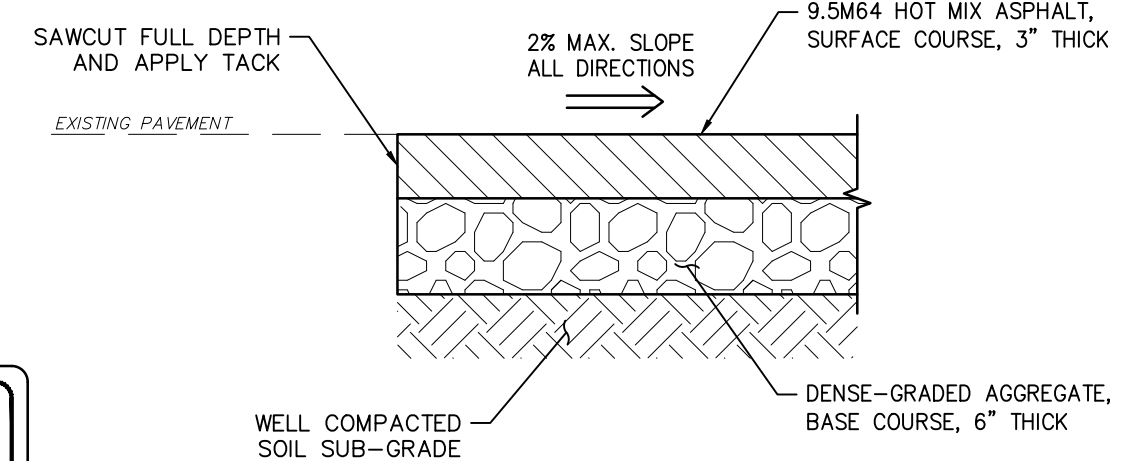

PLANS WHICH DO NOT BEAR AN EMBOSSED SEAL ARE NOT VALID.

ALL DOCUMENTS PREPARED BY REMINGTON & VERNICK ENGINEERS AND AFFILIATES ARE INSTRUMENTS OF SERVICE IN RESPECT OF THE PROJECT. THEY ARE NOT INTENDED OR REPRESENTED TO BE SUITABLE FOR REUSE BY OWNER OR OTHERS ON EXTENSIONS OF THE PROJECT OR ON ANY OTHER PROJECT. ANY REUSE WITHOUT WRITTEN VERIFICATION OR ADAPTATION BY REMINGTON & VERNICK ENGINEERS AND AFFILIATES FOR THE SPECIFIC PURPOSE INTENDED WILL BE AT OWNERS SOLE RISK AND WITHOUT LIABILITY OR LEGAL EXPOSURE TO REMINGTON & VERNICK ENGINEERS AND AFFILIATES, AND OWNER SHALL INDEMNIFY AND HOLD HARMLESS REMINGTON & VERNICK ENGINEERS AND AFFILIATES FROM ALL CLAIMS, DAMAGES, LOSSES AND EXPENSES ARISING OUT OF OR RESULTING THEREFROM.

NO.	REVISION	DATE	BY	CHK

CONSTRUCTION PLAN
 BLACK RUN RESERVE
 TOMLINSON MILL ROAD TRAIL IMPROVEMENTS
 BURLINGTON COUNTY
 EVESHAM BOROUGH
 NEW JERSEY

DRAWN BY:	DESIGN BY:	CHECKED BY:	SCALE:
J.J.M.	T.R.S.	T.R.S.	AS NOTED
DATE:	01/2024		
JOB No.:	03131246		

1 of 1

REVISIONS				
NO.	DESCRIPTION	DATE	BY	CHK BY
1	TRAIL MAP	8/22/22	KT	
2	FORMATTING	9/21/22	LP	
3	FORMATTING	9/27/22	LP	
4	FORMATTING	12/7/2023	ES	
5	FORMATTING	1/4/2024	ES	

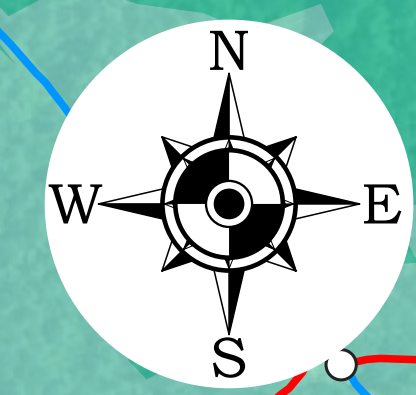

Proposed Kettle Run South Parking Area
2 Spaces

Proposed Bortons Road Parking Area
11 Spaces

REI White Bike Trail
1993-0341.007

Legend	
	Black Run Boundary
	Trail Intersection
	Bridge
	Bridge - Legacy
	Bridge - Plank
	Proposed Parking
Black Run Preserve Trails	
	Approved
	Before 1980
	Pre-1979
	Request Approval
	Unapproved
	Stream/River
	Lake
	No Trail Area
	Parcel
	ROSI Parcel
	Wetlands
	Wetlands (300' Buffer)

General Notes & Data Sources:
This Geographic Information System (GIS) Black Run Preserve Trail Map is for demonstration purposes only, any use of this product with respect to accuracy and precision shall be the sole responsibility of the end user.

The areas, boundaries and details, shown on this Black Run Preserve Trail map, are referenced, in part, from ground surveys, aerial surveys and recorded plans, tax assessment maps and documents, and are to be used for reference purposes only. Bicycle routes and trails acquired in part from the Township of Evesham GIS data, Evesham Township Bikeway Plan, 8/12/03 produced by Orth-Rodgers & Associates, Inc and the Cross County Connection Bike Map of Evesham.

This map is based, in part, on trail assets field located and data collected in Black Run Preserve utilizing GPS equipment and mapped in a CADD drawing file format, performed, and provided by Charles Chelotti PE/Engineering Design Studio LLC. This digital data was collected approximately 3/20/2020 and mapped approximately 6/14/2022. The Overall Delineated Wetlands Plan was performed by Adams, Rehmann & Heggan (ARH), 6/5/2016.

This map was created, in part, utilizing parcel data provided by Burlington County via NJGN as of 2023, and updated by Remington & Vernick Engineers in 2023.

Additional GIS resource data was provided by the New Jersey Geographic Information Network (NJGIN), the New Jersey Department of Transportation (NJDOT), the New Jersey Department of Environmental Protection (NJDEP), the New Jersey Office of Information Technology (NJOT), and the New Jersey Office of GIS (NJOGIS). The data was obtained and provided by the various New Jersey Departments at the New Jersey Geographic Information Network (NJGIN) <https://njgis-newjersey.opendata.arcgis.com>. This secondary product has not been verified by (NJGIN/NJOT/NJOGIS/NJDOT/NJDEP) and is not state-authorized.

All positions are based on the following:

- NAD 83 (horizontal datum)
- New Jersey State Plane Coordinate System
- English units (US Survey Feet)

The geodetic accuracy and precision of the Geographic Information System (GIS) data contained in this mapping has not been developed nor verified by a professional licensed land surveyor and shall not be nor is intended to be used in matters requiring delineation and location of true ground horizontal and/or vertical controls, unless otherwise noted.

DRAFT

Parcels of Black Run Preserve			
Block	Lot	Block	Lot
57	1	57	1.01

Application No	Description
1989-0719.27	Pedestrian Bridge
1993-0341.005	Long Bog Bridge, split rail fence, stone dust surface
1993-0341.006	Long Bog Bridge, split rail fence, stone dust surface
1993-0341.007	REI White Trail
1993-0341.008	Overall Trail Map

**Black Run Preserve
Southern Section (Aerohaven)
Trail Map**

Evesham Township

Burlington County New Jersey
08/22/2022 Scale 1:200

REMINGTON & VERNICK ENGINEERS
2059 SPRINGDALE ROAD, CHERRY HILL, NJ 08003
(856) 795-9595, FAX (856) 795-1882, RVE.COM
Certificate of Authorization: 24 GA 28003300
Excellence • Innovation • Service

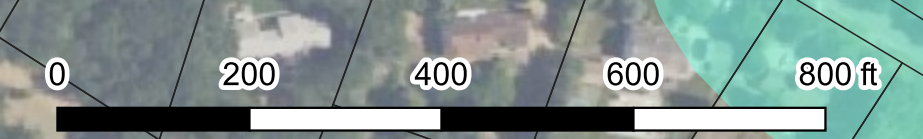



Township of Evesham "Respecting Diversity, Preserving Dignity"

Mayor Jaclyn Veasy - Councilwoman Heather Cooper - Councilwoman Ginamarie Espinoza - Councilman Eddie Freeman, III - Councilwoman Patricia Hansen

984 Tuckerton Road • Marlton • NJ 08053 • 856-983-2900 • www.evesham-nj.org

3. Proposed MOA Summary:

In effort to address the overall permitting status of the 700+ acre park, the Township proposes to keep moving forward to document all the trails, parking areas, and items within the park to the Township is seeking permission to remain (kiosk signage and benches). As evidenced by historic aerial imagery most of the trails have existed in the BRP since pre 1979. Additionally, the request includes an existing trail (shown in red on the overall map for the southern section) for permission to remain.

The request includes consideration for direction to continue moving forward with a MOA project that will include approval of the following:

- 1) Western Section: Change in existing trail material surface from earthen to crushed gravel (as was approved for Pemberton Lakes Trail). 4,640 linear feet @ a width of 5 feet, the proposed disturbance is 23,200 square feet, or 0.53 acres. The proposed trail improvements would make the existing trail firm, stable and flat from side to side so it is more accessible to individuals with mobility issues.
- 2) Western Section: Installation of one pedestrian ADA compliant bridge to reconnect two existing trails (that are proposed to be include ADA upgrades).



Township of Evesham "Respecting Diversity, Preserving Dignity"

Mayor Jaclyn Veasy - Councilwoman Heather Cooper - Councilwoman Ginamarie Espinoza - Councilman Eddie Freeman, III - Councilwoman Patricia Hansen

984 Tuckerton Road • Marlton • NJ 08053 • 856-983-2900 • www.evesham-nj.org

- 3) To permit existing park amenities to remain including board walks, kiosk signage at parking area, park signage, and benches. To allow additional newly proposed park amenities including park signage and benches as appropriate.
 - 4) To permit 5 existing parking areas to remain and to include changes in surface material to allow the installation of ADA compliant parking spaces.
 - 5) To permit the existing trail shown in red (southern section) to remain.
4. Partners involved in this effort to address permitting within the BRP:
- i. Evesham Township
 - ii. Friends of Black Run Preserve
 - iii. Pinelands Preservation Alliance

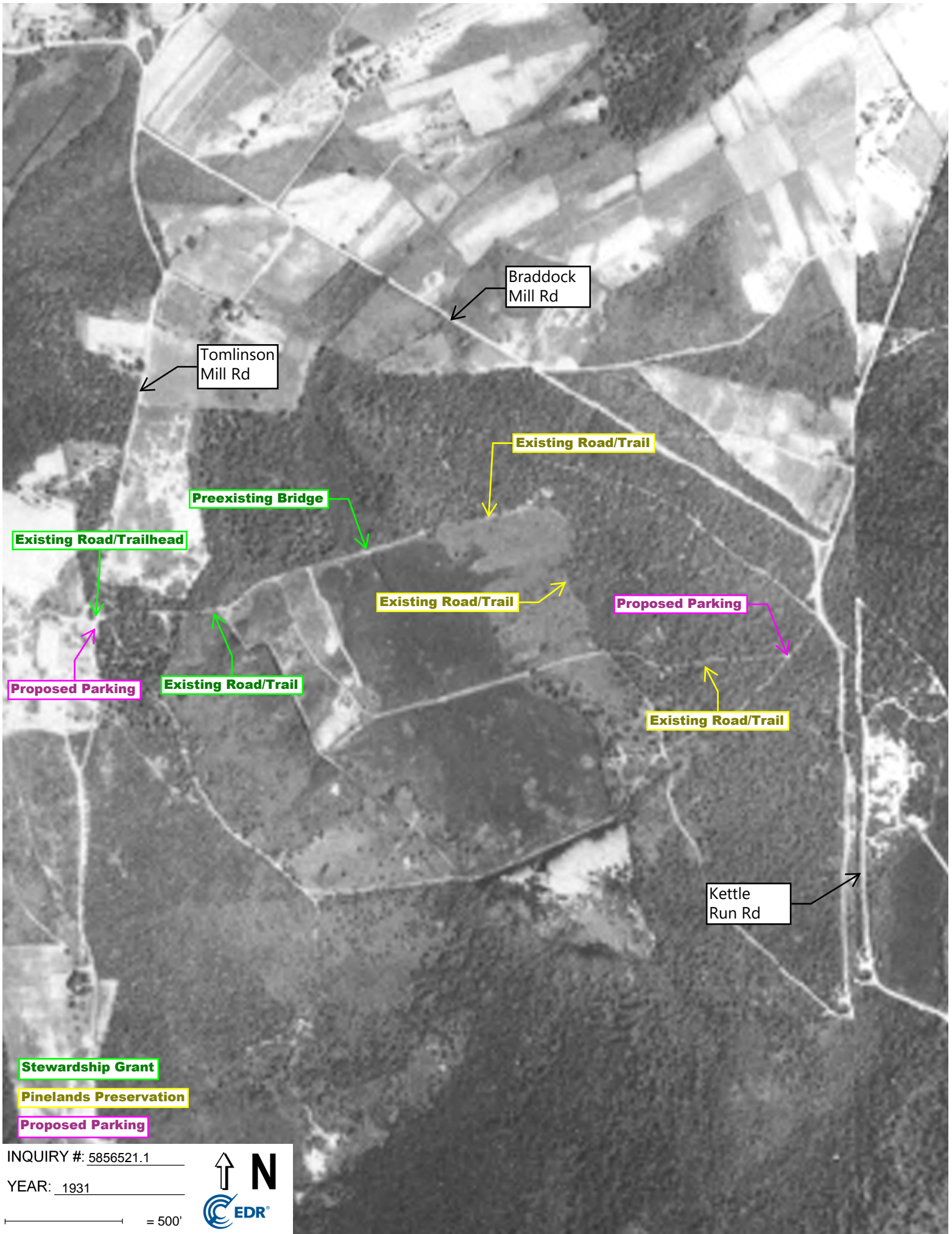

Braddock Mill Rd

Tomlinson Mill Rd

Existing Road/Trail

Preexisting Bridge

Existing Road/Trailhead

Existing Road/Trail

Proposed Parking

Proposed Parking

Existing Road/Trail

Existing Road/Trail

Kettle Run Rd

Stewardship Grant

Pinelands Preservation

Proposed Parking

INQUIRY #: 5856521.1

YEAR: 1931

Scale bar: = 500'



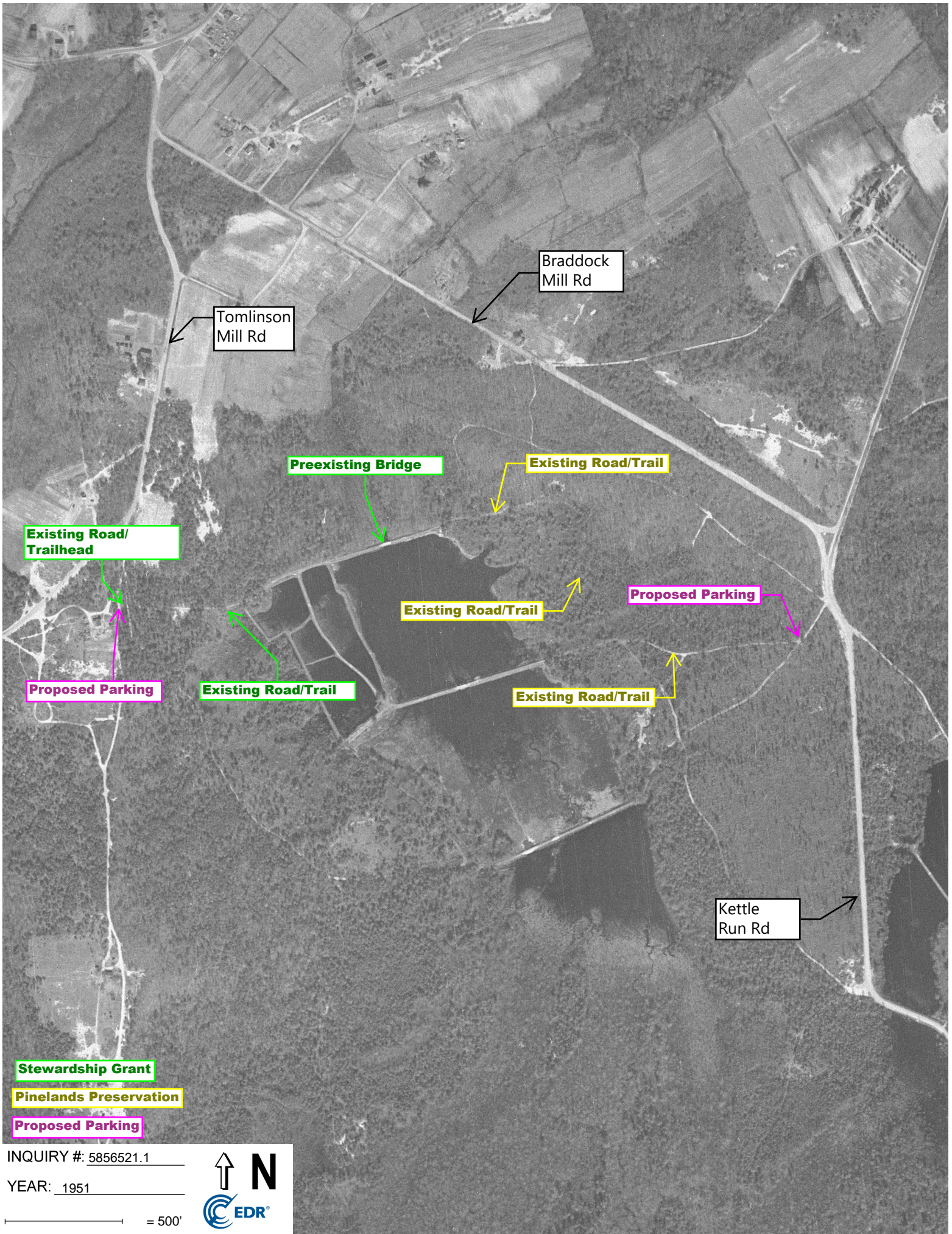

Braddock Mill Rd

Tomlinson Mill Rd

Preexisting Bridge

Existing Road/Trail

Existing Road/Trailhead

Existing Road/Trail

Proposed Parking

Proposed Parking

Existing Road/Trail

Existing Road/Trail

Kettle Run Rd

Stewardship Grant

Pinelands Preservation

Proposed Parking

INQUIRY #: 5856521.1

YEAR: 1951

— = 500'



Black Run Preserve Accessibility Trail Enhancement



PINELANDS
PRESERVATION
ALLIANCE



Proposal by Pinelands Preservation Alliance and Evesham Twp.

The importance of this project

1. Create an inclusive low-impact recreation site for the community.
2. Promote community health and wellness.
3. Provide a safe space for gathering and activity for everyone.
4. Encourage low-impact activity for all members of the community.
5. Provide inclusive access to conserved wild areas with great scenic views.
7. Help all residents connect with Evesham's natural places.
8. Improve overall value of the preserve for the community.

Scouting the Site



Scouting the Site



Scouting the Site



Why do the work: Health, Recreation, Education, Community Connection



Why do the work: Health, Recreation, Education, Community Connection



Why do the work: Health, Recreation, Education, Community Connection



Examples of Similar Work: County Park Level



Boundary Creek – Burlington County Parks

Examples of Similar Work: County Park Level



Eno's Pond – Ocean County Parks

Examples of Similar Work: State Park Level



Wharton State Forest, Batsto Village –
Red Trail



Atsion Recreation Area – Red/Blue
Trail

Examples of Similar Work: State Park Level



Brendan T. Byrne State Forest – Cranberry Trail



Township of Evesham

"Respecting Diversity, Preserving Dignity"

Mayor Jaclyn Veasy - Councilwoman Heather Cooper - Councilwoman Ginamarie Espinoza - Councilman Eddie Freeman, III - Councilwoman Patricia Hansen

984 Tuckerton Road • Marlton • NJ 08053 • 856-983-2900 • www.evesham-nj.org

5. Offset Approximate Work Area = 8+ Acres. Restoration of former MUA basins.

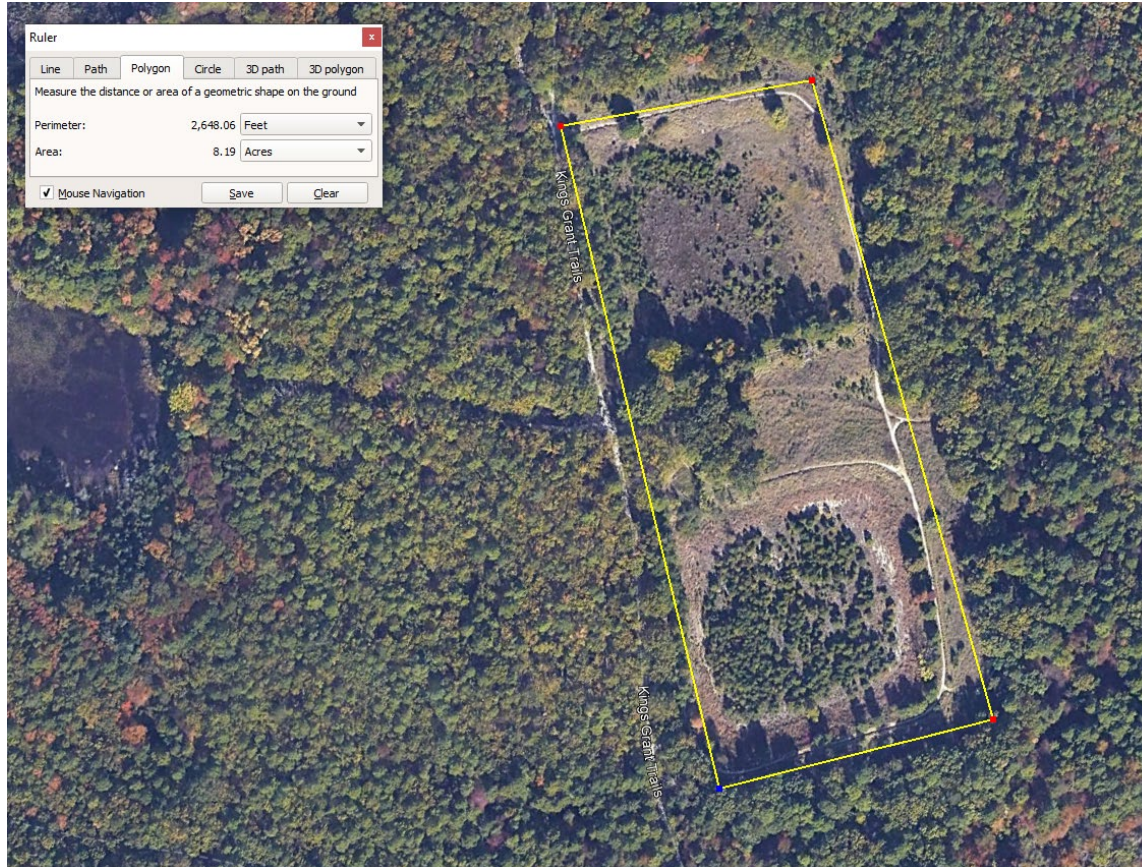

Pinelands Conservation Fund Priorities, Funding & Schedule

Policy & Implementation Committee
February 23, 2024

Background

- Permanent land protection:
 - 51% of Pinelands Area
- 20 Planning & Section 502 Acquisition Target Areas
 - All appropriated Federal funding for Section 502 areas expended
 - Rely on PCF to achieve Permanent Land Protection goals (\$9.5 M/8,971 acres preserved to date)
- Additional \$3 M funding added to PCF through SJTA MOA 2019-2024
- PCF acquisition priorities revised in 2021, but few projects

Land Acquisition Priorities -2021

- Grassland habitats
- Impacts of climate change
 - Fire hazard
 - Flood hazard
 - Carbon sequestration
- “Traditional” acquisitions
 - 502 Fund Areas
 - 20 Acquisition Target Areas

Grassland Focus Area

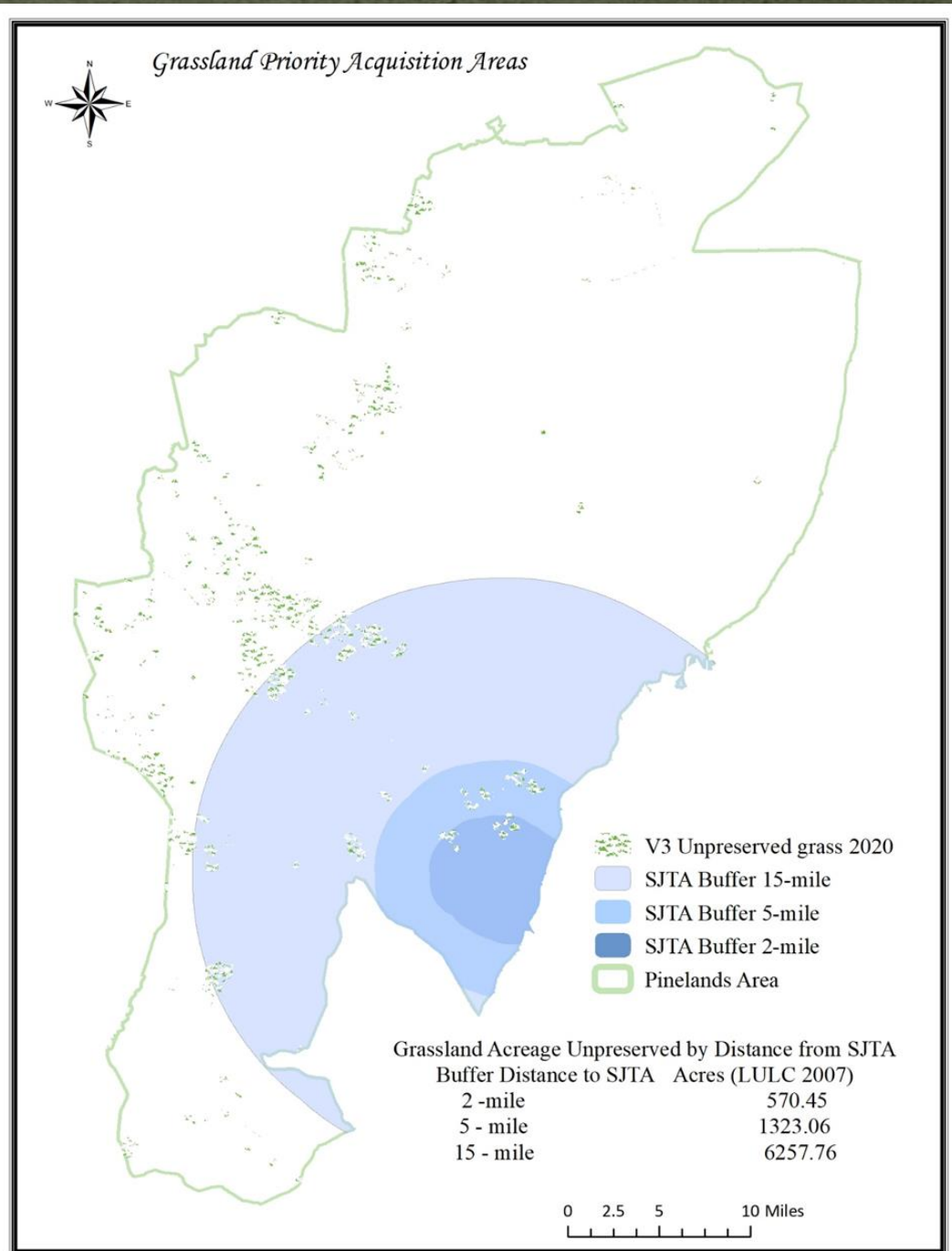

Project Evaluation Matrix

2021 & 2022

Factor	Low (1)	Medium (3)	High (5)
Location: Is the project in PCF focus area	In RGA, Town, Village or Rural Development Area AND none of the designated focus areas	In designated focus areas and PAD, SAPA, APA or Forest Area	Within a five-mile radius of SJTA and inside the State Pinelands Area
T&E Habitats:	No state/federal T&E habitat per NJDEP Landscape Model AND no NJPC and ENSP sightings	T&E habitat exists based upon NJDEP Landscape model and/or NJPC and ENSP sightings	Grassland habitat exists based upon NJDEP Landscape model and/or NJPC and ENSP sightings
Size:	Less than 50 acres	Between 50 and 100 acres	100 acres or more; add 3 additional points if greater than 500 acres
Contiguity:	Greater than one mile from preserved habitat or open space	Less than one mile from known grassland T&E habitats but not contiguous	Contiguous with preserved habitat or open space
Partner Contribution:	67.7% of acquisition costs	At least 75% acquisition costs	Greater than 75% acquisition costs
Long-Term Maintenance Capability:	No monitoring or maintenance plan/ no identified land steward	Proposed Monitoring and maintenance plan; Not previously implemented	Established Monitoring and maintenance program / Gov't. agency or NGO is prepared to manage land
Climate Change Mitigation:	Flood hazard mitigation	Wildfire Management	Carbon Sequestration/ Storage
Purpose:	Historic Preservation	Open Space	T & E or Climate Change

Extra points for carbon sequestration involving Atlantic cedar swamps.

2024 Changes

Goals to be
achieved

- Increase project participation over recent years' PCF rounds
- Support climate mitigation identified by Climate Committee PMA boundary analysis
- Address environmental justice initiatives
- Continue to build successful stewardship of preserved lands
- Add two Acquisition Target “planning” areas

Project Priorities - 2024

Acquisition target areas

- Climate committee recommendations for one expanded and one new acquisition target area
 - Maurice River Township – Port Elizabeth-Bricksboro Village
 - Pemberton Township – RGA

Priority Matrix changes

- Add PCF criteria for location in or adjacent to overburdened communities
- Maintenance agreement
- Additional points awarded for grassland maintenance objective

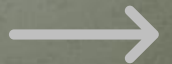

Expanded Acquisition Target Area

- Came from Pinelands Management Area analysis for climate change impacts
- Endorsed by the Climate Committee

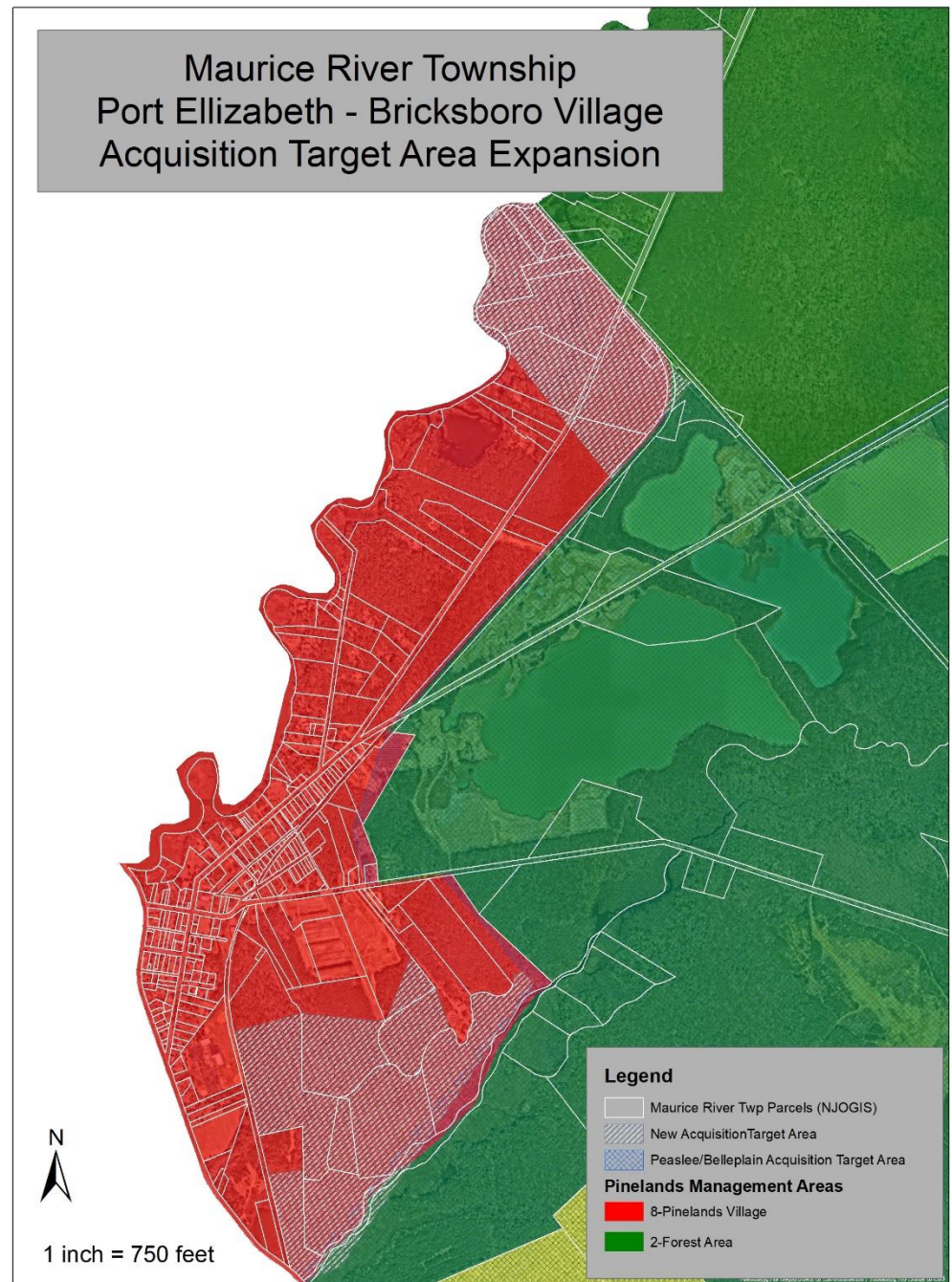

New Acquisition Target Area

- Came from Pinelands Management Area analysis for climate change impacts
- Endorsed by the Climate Committee

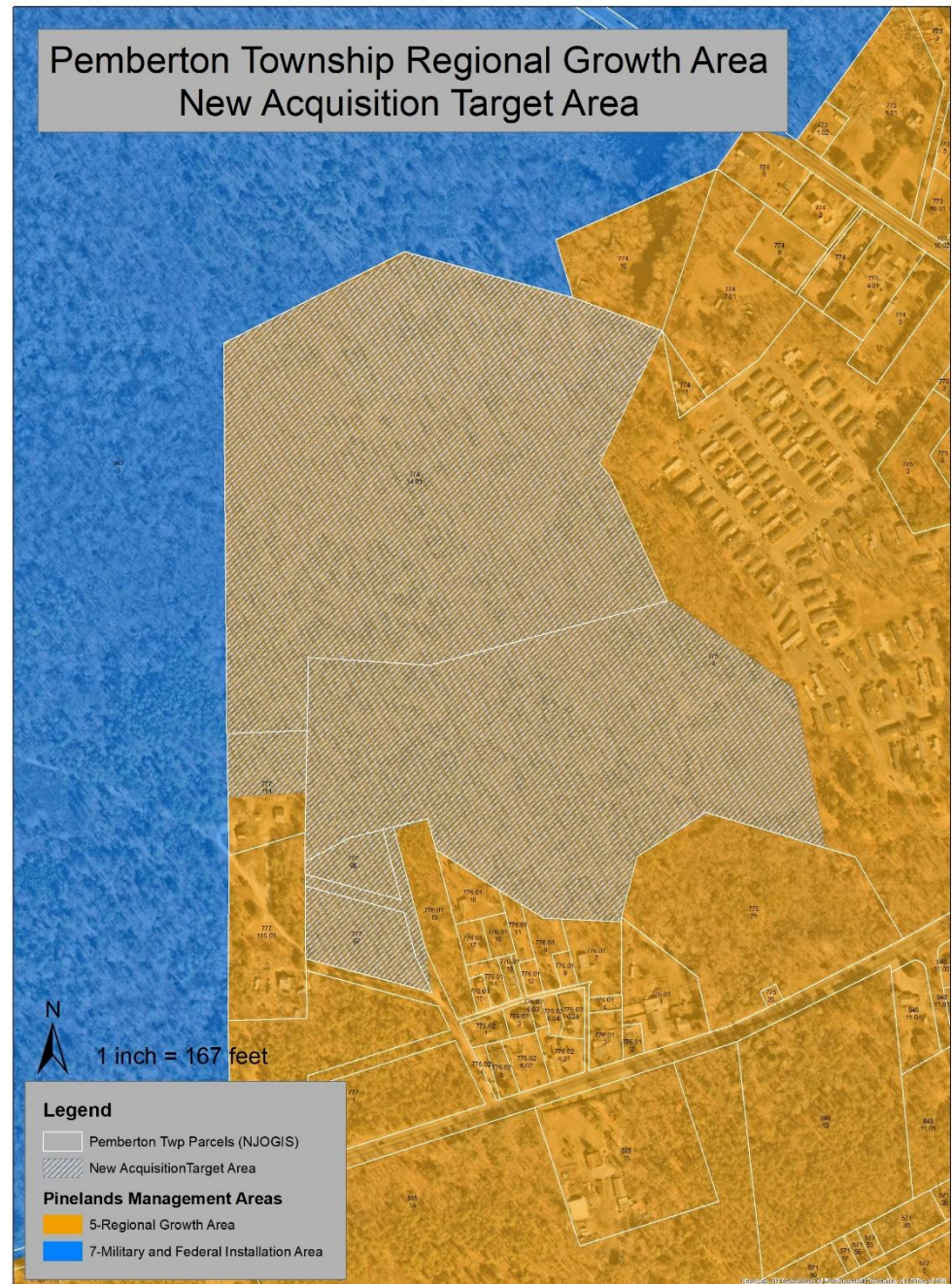

Project Evaluation Matrix

2024

Factor	Low (1)	Medium (3)	High (5)
Location ¹ : Is the project in PCF focus areas for flood or wildfire	In RGA, Town, Village or Rural Development Area AND one of the designated focus areas	In designated focus areas and PAD, SAPA, APA or Forest Area	Within a five-mile radius of SJTA and inside the State Pinelands Area
T&E Habitats ² :	No state/federal T&E habitat per NJDEP Landscape Model AND no NJPC and ENSP sightings	T&E habitat exists based upon NJDEP Landscape model and/or NJPC and ENSP sightings	Grassland habitat exists based upon NJDEP Landscape model and/or NJPC and ENSP sightings
Size:	Less than 50 acres	Between 50 and 100 acres	100 acres or more; add 3 additional points if greater than 500 acres
Contiguity:	Less than one mile from preserved open space	Less than one mile from known grassland T&E habitats but not contiguous	Contiguous with preserved habitat or open space
Partner Contribution:	66.7% of acquisition costs	At least 75% of acquisition costs	Greater than 75% of acquisition costs
Maintenance & Stewardship:	Written maintenance /stewardship plan	Written maintenance/ stewardship plan and specific stewardship project proposal	Written maintenance/ stewardship plan and agreement to partner on future grant proposal for stewardship projects
Environmental Justice Communities Stressors ³ :	One stressor identified	Three or four stressors identified	More than five stressors identified

Add'l Evaluation Notes

- Projects must be located in Section 502 acquisition target areas or in one of the Pinelands Commission identified 21 acquisition target areas
- An additional three points will be awarded for projects that are intended to preserve open space with the objective of maintaining grassland habitat.
- Environmental Justice Community stressors are identified by NJDEP and include: high ozone, heavy traffic, known contaminated sites, solid waste facilities, and impaired surface water among other stressors.

Funding Structure Changes

- Enhance stewardship success
 - Increase traditional 33% PCF match for projects with specific stewardship plans
 - Allow partner to set aside funds for stewardship
 - No change in funding for other projects
- Build a better grant proposal (future ATB?)
 - Identify sites
 - Partners
 - Projects
 - Costs
 - Benefits

Permanent Land Protection Schedule (2024)

- P & I Authorization of PCF Priorities - February
- Preservation Summit – early April
- Report on Summit – April P & I Committee
- Open application round ~ early May
- Deadline for submitting proposals ~ September
- Project Recommendations to P & I ~ October



RESOLUTION OF THE NEW JERSEY PINELANDS COMMISSION

NO. PC4-24-_____

TITLE: Issuing an Order to Certify Manchester Township Ordinance 24-02, Adopting the Redevelopment Plan for Block 62, Lots 30 and 31.01

Commissioner _____ **moves and Commissioner** _____
seconds the motion that:

WHEREAS, on July 8, 1983, the Pinelands Commission fully certified the Master Plan and Land Use Ordinances of Manchester Township; and

WHEREAS, Resolution #PC4-83-59 of the Pinelands Commission specified that any amendment to the Township's certified Master Plan and codified Land Use Ordinances be submitted to the Executive Director in accordance with N.J.A.C. 7:50-3.45 (Submission and Review of Amendments to Certified Master Plans and Land Use Ordinances) of the Comprehensive Management Plan to determine if said amendment raises a substantial issue with respect to conformance with the Pinelands Comprehensive Management Plan; and

WHEREAS, Resolution #PC4-83-59 further specified that any such amendment shall only become effective as provided in N.J.A.C. 7:50-3.45 of the Comprehensive Management Plan; and

WHEREAS, on January 22, 2024, Manchester Township adopted Ordinance 24-02, adopting a Redevelopment Plan for Block 62, Lots 30 and 31.01, both of which are located in a Pinelands Regional Growth Area; and

WHEREAS, the Pinelands Commission received a certified copy of Ordinance 24-02 on February 15, 2024; and

WHEREAS, by letter dated March 7, 2024, the Executive Director notified the Township that Ordinance 24-02 would require formal review and approval by the Pinelands Commission; and

WHEREAS, a public hearing to receive testimony on Ordinance 24-02 was duly advertised, noticed and remotely held on April 3, 2024, at 9:30 a.m. with live broadcast on the Pinelands Commission's public YouTube channel and opportunity for the public to call-in during the live broadcast; and

WHEREAS, the Executive Director has found that Ordinance 24-02 is consistent with the standards and provisions of the Pinelands Comprehensive Management Plan; and

WHEREAS, the Executive Director has submitted a report to the Commission recommending issuance of an order to certify that Ordinance 24-02, adopting the Redevelopment Plan for Block 62, Lots 30 and 31.01, is in conformance with the Pinelands Comprehensive Management Plan; and

WHEREAS, the Commission's CMP Policy and Implementation Committee has reviewed the Executive Director's report and has recommended that Ordinance 24-02 be certified; and

WHEREAS, the Pinelands Commission has duly considered all public testimony submitted to the Commission concerning Ordinance 24-02 and has reviewed the Executive Director's report; and

WHEREAS, the Pinelands Commission accepts the recommendation of the Executive Director; and

WHEREAS, pursuant to N.J.S.A. 13:18A-5h, no action authorized by the Commission shall have force or effect until ten (10) days, Saturdays, Sundays and public holidays excepted, after a copy of the minutes of the meeting of the Commission has been delivered to the Governor for review, unless prior to expiration of the review period the Governor shall approve same, in which case the action shall become effective upon such approval.

NOW, THEREFORE BE IT RESOLVED that

1. An Order is hereby issued to certify that Manchester Township Ordinance 24-02, adopting the Redevelopment Plan for Block 62, Lots 30 and 31.01, is in conformance with the Pinelands Comprehensive Management Plan.
2. Any additional amendments to Manchester Township’s certified Master Plan and Land Use Ordinances shall be submitted to the Executive Director in accordance with N.J.A.C. 7:50-3.45 to determine if said amendments raise a substantial issue with respect to the Comprehensive Management Plan. Any such amendment shall become effective only as provided in N.J.A.C. 7:50-3.45.

Record of Commission Votes

	AYE	NAY	NP	A/R*		AYE	NAY	NP	A/R*		AYE	NAY	NP	A/R*
Avery					Lettman					Rittler Sanchez				
Asselta					Lohbauer					Wallner				
Christy					Mauriello					Matos				
Holroyd					Meade									
Irick					Pikolycky									

*A = Abstained / R = Recused

Adopted at a meeting of the Pinelands Commission

Date: _____

Susan R. Grogan
Executive Director

Laura E. Matos
Chair



State of New Jersey
 THE PINELANDS COMMISSION
 PO Box 359
 NEW LISBON, NJ 08064
 (609) 894-7300
 www.nj.gov/pinelands



PHILIP D. MURPHY
 Governor
 TAHESHA L. WAY
 Lt. Governor

General Information: Info@pinelands.nj.gov
 Application Specific Information: AppInfo@pinelands.nj.gov

LAURA E. MATOS
 Chair
 SUSAN R. GROGAN
 Executive Director

Report on Manchester Township Ordinance 24-02, Adopting the Redevelopment Plan for Block 62, Lots 30 and 31.01

April 26, 2024

Township of Manchester
 1 Colonial Drive
 Manchester, NJ 08759

Findings of Fact

I. Background

The Township of Manchester is located in the northern portion of the Pinelands Area in northwestern Ocean County. Pinelands municipalities adjacent to Manchester Township include the Borough of Lakehurst and the Townships of Berkeley, Jackson, Lacey, Plumsted, and Toms River in Ocean County, and the Townships of Pemberton and Woodland in Burlington County.

On July 8, 1983, the Pinelands Commission fully certified the Master Plan and Land Use Ordinances of Manchester Township applicable to that portion of the municipality located in the state-designated Pinelands Area.

In 2003, the Commission organized the Toms River Corridor Task Force to develop a plan for protecting critical natural resources in the Toms River watershed of Jackson and Manchester Townships. The project area covered approximately 2,000 acres of Manchester Township and 15,000 acres of Jackson Township. The Task Force was comprised of 19 representatives from government planning and environmental agencies, non-profit conservation groups, and others, and received expert support from technical advisors on botany, herpetology, geology, hydrology and other key fields. The Task Force produced a report entitled, A Regional Natural Resource Protection Plan for the Toms River Corridor¹. This Plan recommended use of a combination of planning, zoning and resource protection tools for the area. A series of Pinelands management area redesignations were proposed to provide greater protection of water quality and critical wildlife habitat. Enhanced buffers and establishment of connectors between large areas of undeveloped and protected habitat were also recommended, along with reductions in housing density, mandatory cluster development and enhanced permanent land protection efforts. On

¹ The Regional Natural Resource Protection Plan for the Toms River Corridor may be accessed at the following link:
https://www.nj.gov/pinelands/landuse/recent/toms/toms_river_corridor.pdf

March 12, 2004, the Pinelands Commission endorsed the Toms River Corridor Plan via Resolution No. PC4-04-22.

Between 2004 and 2008, Manchester and Jackson Townships amended their master plans and ordinances to implement the management area and zoning changes recommended in the Toms River Corridor Plan, resulting in significant decreases in permitted development intensities throughout the region. In total, 1,100 acres of Jackson's Pinelands Villages were redesignated to either Forest Area or Rural Development Area, 760 acres of Jackson's Rural Development Area were redesignated to Forest Area, and 725 acres of Jackson and Manchester Township's Regional Growth Area were redesignated to Rural Development Area. Additionally, both municipalities adopted requirements for the establishment of upland wildlife corridors along the main stem of the Toms River and the Ridgeway Branch. Finally, the Commission helped to fund the permanent protection of nearly 900 acres within the Toms River Corridor by providing grants from the Pinelands Conservation Fund to the Ocean County Natural Lands Trust and the Trust for Public Land.

On January 22, 2024, Manchester Township adopted Ordinance 24-02, approving a Redevelopment Plan for Block 62, Lots 30 and 31.03, both of which are located in a Pinelands Regional Growth Area. The Pinelands Commission received a certified copy of Ordinance 24-02 on February 15, 2024.

By letter dated March 7, 2024, the Executive Director notified the Township that Ordinance 24-02 would require formal review and approval by the Pinelands Commission.

II. Master Plans and Land Use Ordinances

The following ordinance has been submitted to the Pinelands Commission for certification:

- * Ordinance 24-02, Adopting the Redevelopment Plan for Block 62, Lots 30 and 31.01, introduced on January 2, 2024 and adopted on January 22, 2024.

This ordinance has been reviewed to determine whether it conforms with the standards for certification of municipal master plans and land use ordinances as set out in N.J.A.C. 7:50-3.39 of the Pinelands Comprehensive Management Plan (CMP). The findings from this review are presented below. The numbers used to designate the respective items correspond to the numbers used to identify the standards in N.J.A.C. 7:50-3.39.

1. Natural Resource Inventory

Not applicable.

2. Required Provisions of Master Plans and Land Use Ordinances Relating to Development Standards

Redevelopment Plan for Block 62, Lots 30 and 31.01

Ordinance 24-02 adopts the Redevelopment Plan for Block 62, Lots 30 and 31.01, dated December 28, 2023. The two lots that compose the new redevelopment area are approximately 224 acres in area. The redevelopment area is bordered by an existing rail line to the southeast, a

tributary to the Ridgeway Branch of the Toms River to the southwest, a parcel preserved by Ocean County to the north, and a recycling center and asphalt plant to the northwest in Jackson Township (see Exhibit #1). The redevelopment area is the site of a former resource extraction operation that was intermittently mined between the late 1970s and mid-1990s. The site is currently vacant. An age-restricted community known as Renaissance Village is located to the east of the existing rail line, outside the Pinelands Area. An existing, private, two-lane road known as Freemont Avenue traverses the northern border of the redevelopment area. The Renaissance Village community has easement rights to use Freemont Avenue for secondary access from dawn until dusk. The entirety of the redevelopment area is located in the Township's Pinelands Environmental Development-1 (PED-1) District, which is within a Pinelands Regional Growth Area.

The goals of the Redevelopment Plan are: to make productive use of a vacant, former mining site; to increase and diversify the Township's tax base with private, non-residential development; to protect and conserve sensitive environmental areas; to take advantage of the tract's accessibility to U.S. Route 9, State Routes 37 and 70, and the Garden State Parkway; to encourage development of local warehouse uses, for which there is a high regional demand; and to design a non-residential development that has minimal impacts on residential and environmental areas.

To those ends, the Redevelopment Plan establishes an optional overlay zoning district encompassing the entire redevelopment area. The underlying PED-1 District remains in effect, and development may occur in accordance with the requirements of the PED-1 District if this redevelopment plan is not implemented. Permitted uses in the optional overlay zone include light industrial uses, warehouses, distribution centers, wholesaling, flex space, indoor recreation, scientific and research facilities, business or professional offices, and indoor agriculture. Conditionally permitted uses include online commerce businesses, with both order fulfillment and direct-to-consumer retail sales operations, and outdoor recreation.

For those uses other than outdoor recreation, a maximum gross floor area of 1,200,000 square feet is permitted within the redevelopment area. Outdoor recreation uses are limited to 4 acres and must be associated with the adjacent Renaissance residential community. The redevelopment plan contains various standards for setbacks, parking and circulation requirements, landscaping, lighting, noise mitigation, signs, fences and walls. The plan also requires that all buildings of 100,000 square feet or more be designed and constructed to support rooftop solar installation in accordance with state law (P.L. 2021, c. 290). All development in the redevelopment area is subject to the minimum environmental standards set forth in the Township's land use ordinance and the CMP.

For non-residential development other than outdoor recreation, Pinelands Development Credits (PDCs) are required to be redeemed at a rate of one quarter (1/4) PDC for every 11,500 square feet of gross floor area. For outdoor recreation, PDCs are required to be redeemed at a rate of one quarter (1/4) PDC for every 1.34 acres of conditionally permitted outdoor recreation use.

The redevelopment plan includes a concept plan. In recognition of known critical habitat for threatened and endangered species within the redevelopment area, a conservation area is proposed and rendered on the concept plan (see Exhibit #2). Prior to any development commencing under the redevelopment plan, a conservation area must be permanently protected through deed restriction. No development shall be permitted in the deed-restricted conservation

area, except for the removal of Freemont Avenue as required by the redevelopment plan. The concept plan shows an 88-acre conservation area that is contiguous with the preserved lands to the north of the redevelopment area. The exact delineation of the conservation area will be established during application review by the Pinelands Commission and the Manchester Township Planning Board. Also depicted in the concept plan, as required by the redevelopment plan, is the realignment of Freemont Avenue outside of the depicted conservation area.

The Pinelands Environmental Development District and the Toms River Corridor Plan

The Townships of Manchester and Jackson both established a Pinelands Environmental Development (PED) District as recommended in the Toms River Corridor Plan (see Exhibit #3). In January of 2008, the Commission certified Manchester Ordinance 07-018 establishing the PED-1 and PED-9 districts in Manchester. In November of 2007, the Commission certified Jackson Township Ordinance 07-06, which established a PED-1 and PED-9 districts in Jackson Township along the border and contiguous with its Manchester Township counterparts. In both municipalities, the PED-1 District was located in a Regional Growth Area and the PED-9 District was located in a Rural Development Area.

The PED-1 and PED-9 districts, spanning approximately 615 acres across both municipalities, were the site of multiple former resource extraction operations. The zoning districts were established to allow for the coordinated development of contiguous lands spanning political boundaries in a manner that would maximize the protection of threatened and endangered species habitat while still allowing development on less critical portions of the tract. The establishment of the PED-9 districts in both municipalities required the redesignation of approximately 387 acres from Regional Growth Area to Rural Development Area. Additionally, as recommended by the Toms River Corridor Plan, these four zoning districts incorporated special requirements and incentives to direct permitted development away from areas identified as habitat for threatened and endangered species. This included mandatory clustering of residential units as well as incentives to concentrate all development potential to the PED-1 District in Manchester Township.

The PED-1 District in Manchester Township, which aligns with the boundaries of the redevelopment area under review, permits single family detached units, clustered on 1-acre lots, at a maximum density of one unit per 3.2 acres, with the remainder of the parcel dedicated as open space. The PED-1 District also permits the development of a planned retirement community (PRC). The PRC option is in accordance with the MDG, et al. vs. Manchester Township Settlement Agreement, which was the result of a builder's remedy lawsuit. The PRC option permits the development of up to 350 market rate age-restricted units and a maximum of 35 affordable age-restricted and non-age restricted units. The units are permitted to be either attached or detached single family dwellings, with the remainder of the PED-1 District and all of the PED-9 District in Manchester Township deed restricted as open space. The PRC option also allowed for the clustering of an additional 250 age-restricted units and an additional 25 affordable units from contiguous lands in Jackson Township's PED-1 and PED-9 districts. The lands in Jackson Township would also need to be deed restricted as open space and an intergovernmental agreement between the two municipalities would be required. The PRC option thus allowed for a total of up to 660 units.

Subsequent to establishment of the PED-1 and PED-9 zoning districts, all lands in the PED-9 districts in both Manchester and Jackson Townships were acquired and permanently preserved

by the Trust for Public Land, with funding from the Pinelands Conservation Fund, and the Ocean County Natural Lands Trust.

Residential Zoning Capacity and the Use of Pinelands Development Credits

As noted above, if the redevelopment plan is not implemented, the underlying PED-1 District regulations remain in effect. Therefore, the residential zoning capacity of Manchester Township's Regional Growth Area theoretically remains unchanged. The current residential zoning capacity of the parcels subject to the redevelopment plan is 385 units. As a result of the preservation of the lands within Jackson Township's PED-9 District, there is no longer an opportunity to transfer additional residential development to Manchester Township's PED-1 District.

Based on recent development application activity, there is a strong likelihood that the redevelopment area will be developed exclusively for non-residential use if Ordinance 24-02 is certified. Therefore, Commission staff considered whether the Regional Growth Area portion of the redevelopment area is appropriate for non-residential development and whether the PDC program would be negatively impacted by the expected loss in residential development potential in that area.

Over the years, the lands included in the redevelopment area have been included in various zoning districts. At one time, the larger of the two lots was zoned POR-LI (Pinelands Office, Research and Light Industrial) while the adjacent smaller lot was zoned PR-40 (Pinelands Single-Family Residential) (see Exhibit #3). Both were rezoned to the new PED-1 District in 2007 when the Township implemented the recommendations of the Toms River Corridor Plan and a builders remedy (affordable housing) settlement agreement that called for residential development on the two lots. Given the surrounding land uses, it seems clear that a wide variety of residential and nonresidential uses would be appropriate as part of the Township's overall zoning plan.

Thus, the primary issue for the Commission's consideration is the impact of the redevelopment plan on the PDC program. Importantly, the redevelopment plan includes a PDC requirement for permitted non-residential development in recognition of the potential elimination of up to 385 residential units and opportunities for the use of up to 105 PDC rights if the area is developed for nonresidential use. When a municipality has determined that an area is appropriate for residential development in its Regional Growth Area, zoned it for residential uses and established a PDC obligation, the Commission must carefully evaluate proposals to rezone for strictly non-residential uses with a careful eye to the impacts to the Pinelands Development Credit Program. As discussed in Section 8 below, the PDC requirements for the redevelopment area ensure that the PDC program is not negatively impacted by these amendments.

Ordinance 24-02 is consistent with the land use and development standards of the Comprehensive Management Plan. Therefore, this standard for certification is met.

3. Requirement for Certificate of Filing and Content of Development Applications

All development in the redevelopment area remains subject to the application requirements and procedures in the Township's certified land use ordinance including the need to obtain a

Certificate of Filing from the Pinelands Commission and to meet the minimum application submission requirements.

This standard for certification is met.

4. Requirement for Municipal Review and Action on All Development

All development in the redevelopment area remains subject to the municipal development review procedures in the Township's certified land use ordinance.

This standard for certification is met.

5. Review and Action on Forestry Applications

Not applicable.

6. Review of Local Permits

All development in the redevelopment area remains subject to municipal development review procedures in the Township's certified land use ordinance.

This standard for certification is met.

7. Requirement for Capital Improvement Program

Not applicable.

8. Accommodation of Pinelands Development Credits

N.J.A.C. 7:50-3.39(a)8 specifies that in order to be certified by the Commission, municipal land use ordinances must provide for sufficiently residentially zoned property in the Regional Growth Area to be eligible for an increase in density to accommodate Pinelands Development Credits (PDCs) as provided for in N.J.A.C. 7:50-5.28(a)3.

As noted in Section 2 above, Manchester's certified PED-1 District permits planned retirement communities with a maximum of 350 market-rate age-restricted units and 35 affordable age-restricted units. In the PED-1 District, PDCs must be acquired and redeemed for 30 percent of the non-income restricted housing units in any planned retirement community. This provides an opportunity for the use of up to 105 rights (26.25 full Credits). As noted in Section 2 above, the redevelopment plan establishes an optional zoning overlay. Therefore, if the redevelopment plan is not implemented, the existing PDC provisions and PDC potential remain unchanged.

However, if the redevelopment plan is implemented, any non-residential development permitted under the redevelopment plan is required to redeem PDCs at a rate of one quarter (1/4) PDC for

every 11,500 square feet of gross floor area within principal use and conditional use buildings, except for conditionally permitted outdoor recreation uses. Conditionally permitted outdoor recreation uses are required to redeem PDCs at a rate of 1/4 PDC for every 1.34 acres.

To evaluate whether the PDC requirements of this redevelopment plan adequately protect the Pinelands Development Credit Program, staff evaluated the potential level of PDC redemption under the redevelopment plan. The redevelopment plan permits a maximum gross floor area of 1,200,000 square feet. This equates to a PDC potential of 105 PDC rights (26 full credits) based on the redevelopment plan's PDC provisions, which is equivalent to the PDC potential of 105 rights under the existing PED-1 District. For the four acres of conditionally permitted outdoor recreational uses, an additional 3 rights would be required.

The CMP focuses on the use of PDCs as a means of increasing permitted residential densities in Regional Growth Areas. However, N.J.A.C. 7:50-5.28(a)7i expressly authorizes municipalities to adopt bonus or incentive programs for Regional Growth Area that go beyond the minimum required by the CMP, provided that such programs do not interfere with or otherwise impair the municipality's obligation to provide sufficient opportunities for the use of PDCs. While this provision has not often been used in association with nonresidential development, four other municipalities (Berlin, Monroe, Waterford, and Winslow Townships) previously adopted PDC requirements applicable to nonresidential uses in their commercial and industrial zones. The Commission found that the Berlin, Monroe, Waterford, and Winslow Township ordinances represented an appropriate exercise of municipal flexibility that did not interfere with any other CMP standards and certified them on that basis. Manchester Township Ordinance 24-02 adopts a similarly creative approach, one that facilitates the municipality's redevelopment goals while ensuring that all CMP standards, particularly those related to the PDC program, continue to be met.

This standard for certification is met.

9. Referral of Development Applications to Environmental Commission

All development in the redevelopment area remains subject to the municipal development review procedures in the Township's certified land use ordinance, including the referral of any application to the Township Environmental Commission for review and comment.

This standard for certification is met.

10. General Conformance Requirements

Ordinance 24-02 is consistent with the standards and provisions of the Pinelands Comprehensive Management Plan. Therefore, this standard for certification is met.

11. Conformance with Energy Conservation

Not applicable.

12. **Conformance with the Federal Act**

Ordinance 24-02 is consistent with the standards and provisions of the Pinelands Comprehensive Management Plan. No special issues exist relative to the Federal Act. Therefore, this standard for certification is met.

13. **Procedure to Resolve Intermunicipal Conflicts**

The redevelopment area is located along Manchester Township's municipal boundary with Jackson Township (see Exhibit #1). The redevelopment area abuts Jackson Township's PED-1 and PED-9 districts, both described in Section 2 above, as well as the Pinelands Manufacturing-1 (PM-1) District, which is located in the Regional Growth Area. The PM-1 District permits a variety of industrial uses, including the warehousing or storage of goods and products. The existing recycling center and asphalt plant to the northwest of the redevelopment area are located in the PM-1 District. It is also noted that the single lot within the Jackson Township PED-1 District is in common ownership with the lots in the redevelopment area. Therefore, intermunicipal conflicts are not anticipated and this standard for certification is met.

Public Hearing

A public hearing to receive testimony concerning Manchester Township's application for certification of Ordinance 24-02 was duly advertised, noticed and held on April 3, 2024 at 9:30 a.m. Mr. Lanute conducted the hearing, which was held remotely and broadcasted live on the Pinelands Commission's public YouTube channel. The public was provided the opportunity to call-in during the public hearing to provide testimony. Oral testimony was provided by the following individuals:

Karen Argenti, Vice Chair, Manchester Township Environmental Commission, provided information that was also submitted as written comment (See Exhibit #4).

Mark Rohmeyer, Township Engineer, Manchester Township, stated that his office worked with the developer on the redevelopment plan and that the Township is in support of the redevelopment plan.

Heidi Yeh, Pinelands Preservation Alliance (PPA), stated that PPA is generally supportive of the adaptation of the Pinelands Development Credit (PDC) program to require PDC purchases for commercial and industrial uses instead of just residential development. However, PPA objects to the way that redevelopment provisions of the municipal land use law are abused for deforestation projects like this. PPA understands that the Pinelands Commission is not responsible for whether something qualifies for redevelopment or not, but sees this particular plan manifesting some of the problems with the current redevelopment laws. For example, the land in the northern portion of the property that was previously disturbed for resource extraction will be preserved, while the untouched, forested portion of the site will be "redeveloped." PPA understands that there are concerns with threatened and endangered species that are known to be utilizing the northern portion, but PPA would like to see a thorough snake study to be performed that includes the forested parcel to the south. PPA does not want the upland forest to be sacrificed to compensate for the more apparent limitations of the former extraction site.

Emile DeVito, New Jersey Conservation Foundation (NJCF), stated that NJCF supports everything that Ms. Yeh stated during her testimony. Mr. DeVito provided information that was also submitted as written comment (See Exhibit #5).

Written comments on Ordinance 24-02 were accepted through April 5, 2024 and were received from the following individuals:

Karen Argenti, Vice Chair, Manchester Township Environmental Commission, on behalf of the Manchester Township Environmental Commission (Exhibit #4)

Emile DeVito, Ph.D., New Jersey Conservation Foundation (Exhibit #5)

Executive Director's Response

Comments provided by Ms. Argenti, Ms. Yeh, and Mr. DeVito raised concerns about development within the wooded area of the parcel. As provided in Ms. Argenti's comments, the Manchester Township Environmental Commission supports protecting the existing wooded area of the parcel, limiting warehouse development to those portions of the redevelopment area that have been previously mined, and maintaining the existing location and configuration of Freemont Avenue. Mr. DeVito noted that Northern Pine Snake hibernacula could occur anywhere in the forested patch of the parcel, and that portions of the wooded patch would be excellent habitat for Northern Pine Snake hibernacula. Ms. Yeh and Mr. DeVito both called for thorough snake surveys in the forested area of the parcel.

As noted in Section 2 above, the redevelopment plan requires a conservation area to be deed-restricted prior to any development on the parcel. The location of the proposed conservation area rendered in the redevelopment plan aligns with the existing mined areas of the parcel (see Exhibit #2). While a complete application has yet to be submitted to the Pinelands Commission for a warehouse development, extensive threatened and endangered species surveys have been conducted within the redevelopment area as part of prior development applications. Critical habitat for threatened and endangered animal species as well as threatened and endangered plant populations were found in the previously mined area. The proposed conservation area appropriately aligns with those findings. As noted in Section 2 above, the exact delineation of the conservation area will be established during application review by the Pinelands Commission and the Manchester Township Planning Board. The need for any further surveying within the redevelopment area would be determined during the review of any forthcoming application for development under this redevelopment plan if certified by the Commission.

Ms. Argenti also commented that the materials reviewed by the Manchester Environmental Commission showed proposed stormwater management facilities that are inconsistent with CMP stormwater management regulations and the Township's stormwater management regulations.

It is important to note that any application for development within the redevelopment area will need to demonstrate consistency with the minimum environmental standards of the Pinelands CMP, including those for stormwater management. The Commission has yet to receive a complete development application for any development proposed under this redevelopment plan.

Conclusion

Based on the Findings of Fact cited above, the Executive Director has concluded that Ordinance 24-02, adopting the Redevelopment Plan for Block 62, Lots 30 and 31.01, complies with the Comprehensive Management Plan standards for the certification of municipal master plans and land use ordinances. Accordingly, the Executive Director recommends that the Commission issue an order to certify Ordinance 24-02 of Manchester Township.

SRG/DBL/KLE/CMT
Attachments

Manchester Township Ordinance 24-02

- Pinelands Management Areas**
- Rural Development Area
 - Regional Growth Area
- Legend:**
- Municipal Boundaries
 - Redevelopment Area
 - Municipal Zoning Boundary

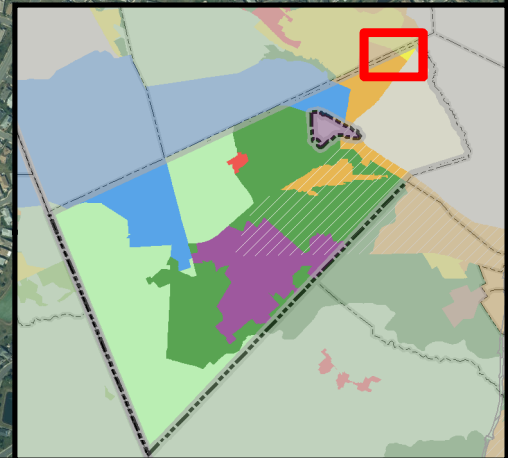
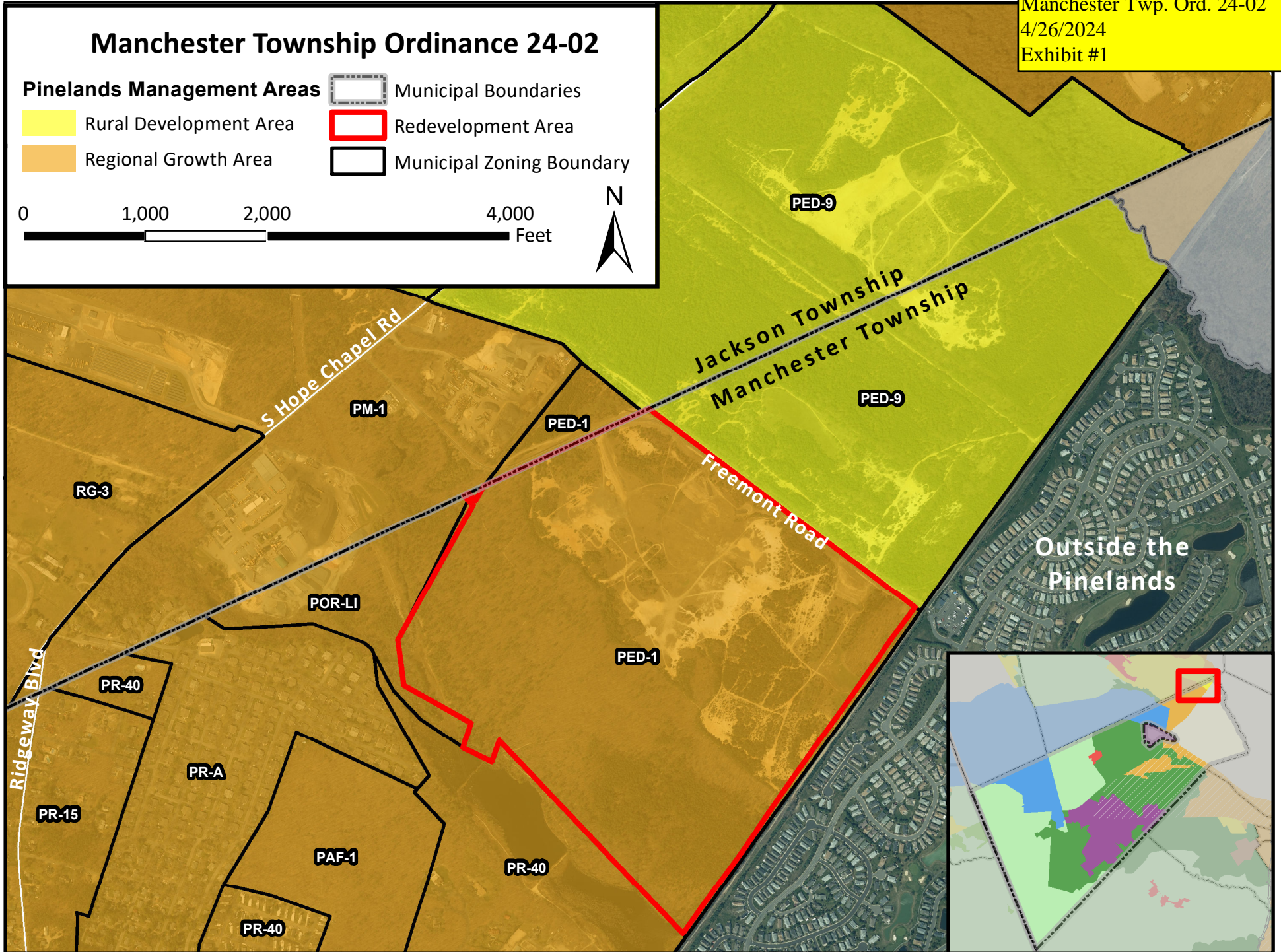
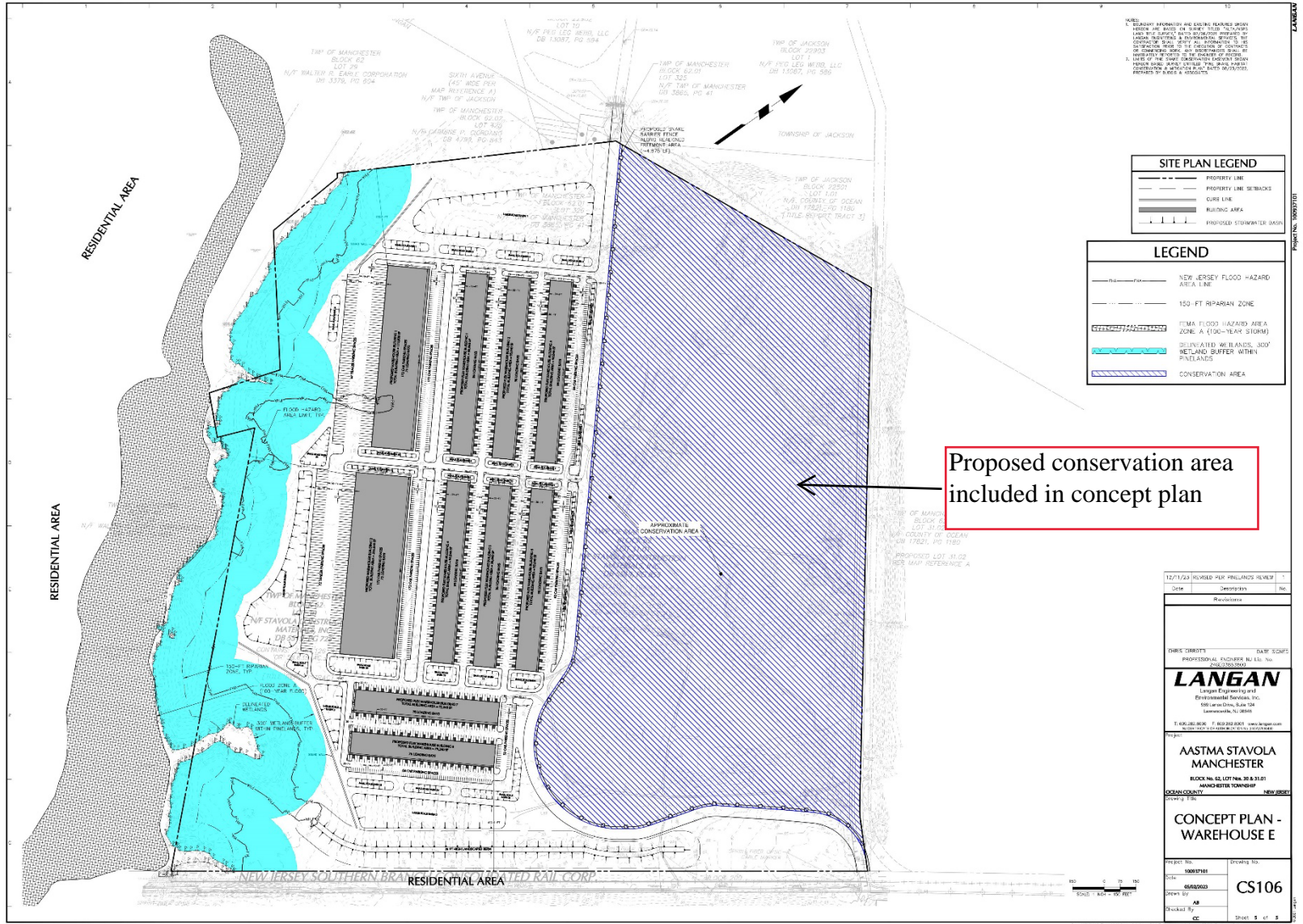

Figure 6 – Illustrative Concept Plan



Code	Description	Rev
Revisions		
TITLE SHEET'S PLUM SCOPES PROFESSIONAL ENGINEERS No. E.C. No. 2501202001		
LANGAN Langan Engineering and Environmental Services, Inc. 100 Lewis Drive, Suite 100 Lenoirville, NJ 08849		
PROJECT NO. 17-00000001-0000-0000 PROJECT NAME: AASTMA STAVOLA MANCHESTER		
BLOCK No. 62, LOTS No. 30 & 31.01 MANCHESTER TOWNSHIP		
CONCEPT PLAN - WAREHOUSE E		
PROJECT NO.	DATE	SCALE
17-00000001-0000-0000	04/26/2024	AS SHOWN
PROJECT NO.	DATE	SCALE
17-00000001-0000-0000	04/26/2024	AS SHOWN
PROJECT NO.	DATE	SCALE
17-00000001-0000-0000	04/26/2024	AS SHOWN

Excerpt Map from
A Regional Natural Resource Protection Plan for the Toms River Corridor (2004)

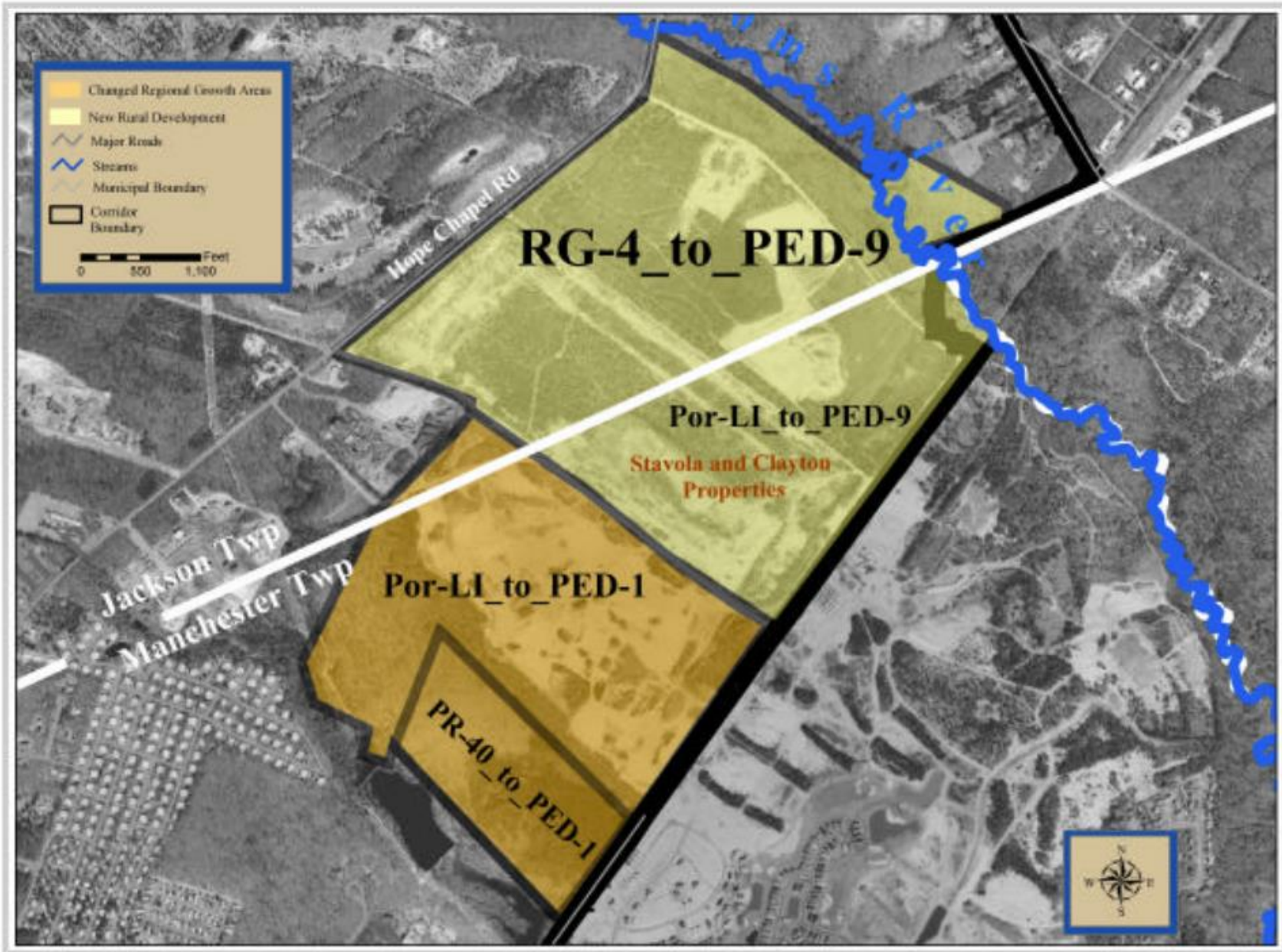

Figure 12. Proposed Changes Associated with the Planned Environmental Development (PED) Zone.

Comments submitted by Karen Argenti, Vice Chair,
Manchester Township Environmental Commission

Manchester Environmental Commission of Manchester Township comments for
New Jersey Pinelands Commission April 3, 2024 Public Hearing on
Manchester Township Ordinance 24-02 Redevelopment Plan for B62, L30 & 31.01

On behalf of the Manchester Environmental Commission of Manchester Township, please accept these comments to the New Jersey Pinelands Commission for the public hearing on April 3, 2024 at 9:30 am on Manchester Township Ordinance 24-02 concerning whether or not the ordinance is in conformance with the Pinelands Comprehensive Management Plan (CMP). Ordinance 24-02 adopts the Redevelopment Plan for Block 62, Lots 30 & 31.01, dated December 28, 2024.

The redevelopment area contains two lots spanning approximately 224 acres. The redevelopment area is currently vacant, but was the site of a former resource extraction operation. It is located within the Township's Pinelands Environmental Development-1 (PED-1) District. The PED-1 District is located within a Pinelands Regional Growth Area.

According to the 2023 CMP (7:50-5.13 (e.) page 111), "Regional Growth Areas are areas of existing growth or lands immediately adjacent thereto which are capable of accommodating regional growth influences while protecting the essential character and environment of the Pinelands, provided that the environmental objectives of Subchapter 6 are implemented through municipal master plans and land use ordinances."

COMMENTS

Three areas concern the Manchester Environmental Commission (MEC): alternative review of site and road location, stormwater management, natural resources protection for T&E, water, and air. We can not speak to the procedures for the redevelopment plan.

ALTERNATIVE REVIEW OF SITE & ROAD LOCATION

MEC commented to the Planning Board and the Town Council concerning the choice of building on the forested land next to the wetland and in a flood plain; and a stormwater plan that used a 100% footprint rather than 30%. An alternative would be to use the former resource extraction operation site, which would allow the use of the existing road and not include the increase new impervious surfaces for the roadway and the forested site. In our opinion, that would be a redevelopment plan. Moreover, by agreeing to cover the entire site with warehouses and motor vehicle surfaces with no set aside to mitigate the impact of increased runoff due to increased impervious surfaces and truck traffic emissions, is not reasonable or responsible.

STORMWATER MANAGEMENT PLAN

The applicant has provided a drawing of the site including a large basin off the other lot section which is also forested. This was approved by the Town Council despite the fact that the recent Stormwater Ordinance is up to date with the Pinelands Commission. There was no discussion of using Green Infrastructure despite the town's adoption of the latest ordinance in the Pinelands -- §245-84. Stormwater management in areas within Pinelands Management Area. [Added 4-28-2008 by Ord. No. 08-013; amended 4-10-2023 by Ord. No. 23-04]

This ordinance clearly identifies that "Flood control, groundwater recharge, erosion control and pollutant reduction shall be achieved using stormwater management measures, *including green infrastructure* best management practices (BMPs) and nonstructural stormwater management strategies. *Green infrastructure* BMPs and low-impact development should be utilized to meet the goal of

Manchester Environmental Commission of Manchester Township comments for
New Jersey Pinelands Commission April 3, 2024 Public Hearing on
Manchester Township Ordinance 24-02 Redevelopment Plan for B62, L30 & 31.01

maintaining natural hydrology to reduce stormwater runoff volume, reduce erosion, encourage infiltration and groundwater recharge, and reduce pollution. *Green infrastructure* BMPs and low-impact development should be developed based upon physical site conditions and the origin, nature and the anticipated quantity, or amount, of potential pollutants. Multiple stormwater management BMPs may be necessary to achieve the established performance standards for water quality, quantity, and groundwater recharge contained in this section.”

The ordinance continues that the “purpose of this section is to establish, within the Pinelands Area portion of Manchester Township, minimum stormwater management requirements and controls as authorized by the Pinelands Protection Act (N.J.S.A. 13:18A-1 et seq.) and consistent with the Pinelands Comprehensive Management Plan (CMP) (N.J.A.C. 7:50-1.1 et seq.) and the New Jersey Department of Environmental Protection (NJDEP) Stormwater Management Regulations (N.J.A.C. 7:8-1.1 et seq.). If there are any conflicts between a provision required by the Pinelands CMP and a provision required by the NJDEP, *the Pinelands CMP provision shall apply.*” (*emphasis added*)

NATURAL RESOURCES PROTECTION

Manchester Natural Resources Inventory and the New Jersey GeoWeb describes both areas protected as the Occupied Habitat **Rank 3** for the Northern Pine Snake. The NJ GeoWeb describes Land Use as EXTRACTIVE MINING and Cover Type as BARREN LAND. If this is chosen, arrangements should be made for the protection and mitigation of that species during construction.

NJ GeoWeb Landscaping Layer shows the Forested section Land Use as a Mixed DECIDUOUS FOREST (>50% CROWN CLOSURE), with a Land Use Cover Type as Forest including Atlantic White Cedar. This section is south west of the Mining site, with occupied habitat **Rank 4** for the Northern Pine Snake and the Timber Rattlesnake, as well as near wetlands. This site should be preserved. See new map attached. This info was presented in the Natural Resources Inventory <https://manchestertwp.com/wp-content/uploads/2021/01/Manchesters-Natural-Resource-Inventory-2020.pdf> and commented on before the Planning Board and Town Council.

CONCLUSION

As stated, the MEC has appeared before both the Manchester Planning Board (PB) and Town Council (TC) to discuss these issues.

Presented by Karen Argenti, Commissioner Vice Chair

Attached NJ GeoWeb map
 Hearing Notice
 May 1, 2023 Letter from NJ Pinelands to applicant (referred to in their proposal)
 MEC Comments to PB on November 6, 2023– 5 pp with attachments – no answer
 MEC Letter to NJ Pinelands on the T&E – not answered
 Emil DeVito’s Comments read into the record of the TC, December 18, 2023
 TC December 18, 2023 item
 Karen Argenti’s MEC Comments to the TC, December 18, 2023
 Pinelands Preservation Alliance & NJ Conservation Foundation Letter to DCA,
 March 25, 2024

NJ-GeoWeb Manchester B62 L30 & 31.01



3/28/2024, 4:12:10 PM

- County Boundaries
- Municipalities
- Rank 1 - Habitat specific requirements
- Rank 2 - Special Concern
- Rank 3 - State Threatened
- Rank 4 - State Endangered
- SBH - Pinelands - Landscape Project

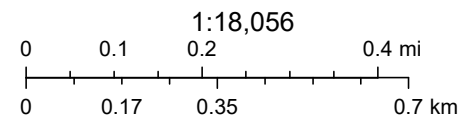

Map data © OpenStreetMap contributors, CC-BY-SA



State of New Jersey
 THE PINELANDS COMMISSION
 PO Box 359
 NEW LISBON, NJ 08064
 (609) 894-7300
 www.nj.gov/pinelands



WILLIAM D. MURPHY
 Governor
 EILA Y. OLIVER
 Lt. Governor

General Information: Info@pinelands.nj.gov
 Application Specific Information: AppInfo@pinelands.nj.gov

LAURA E. MATOS
 Chair
 SUSAN R. GROGAN
 Executive Director

May 1, 2023

Michael Gross, Esq. (via email)
 Giordano Halleran & Ciesla
 125 Half Mile Road, Suite 300
 Red Bank NJ 07701

Re: Application # 1981-1470.009
 Block 62, Lots 30 & 31.01
 Manchester Township

Dear Mr. Gross:

We have reviewed the information submitted on March 22, 2023 regarding the potential residential development of the above referenced 225 acre parcel.

The submitted information included a Proposed Conservation Area plan prepared by Langan Engineering and Environmental Services, Inc. and dated February 14, 2023. The plan depicts the conceptual realignment of Freemont Avenue, the removal of the existing paved cartway of Freemont Avenue and the establishment of an 88 acre conservation area on the parcel. These design techniques are proposed to avoid irreversible impact on habitats that are critical to the survival of local populations of known threatened plant and animal species. The proposed design results in an approximately 100 acre "development area."

Provided the development is limited to the approximately 100 acre "development area" and outside of both the proposed 88 acre conservation area and the required 300 foot buffer to wetlands, based upon currently available information, the proposed development would be consistent with the threatened and endangered species protection standards.

If you have any questions, please contact me.

Sincerely,

 Charles M. Horner, P.P.
 Director of Regulatory Programs

Project Description

Manchester Township Block 62, Lots 30, & 31.01. There is one street, Fremont Avenue, a dirt road currently. Located in the Pinelands area of town, it is zoned PED-1 and was deemed an Area in Need of Redevelopment last year. It is now in the Plan Development. The current proposal is to declare the mine area an 88-acre Conservation District, and develop the forested area. It is at the edge of town at the intersection of Jackson and near Toms River. It is adjacent to a big development called The Renaissance which uses Fremont as its emergency exit only. There is a railroad somewhere.

We checked the T & E in the [2020 Manchester Natural Resource Inventory](#), and it has the Landscape Project where two areas ranked 3 (abandoned mine) and 4 (forest and wetland). Pp 38-40

Landscape Project Data

The NJDEP Endangered and Non-Game Species Program created the Landscape Project as an ecosystem level approach to identifying and protecting species habitat in the state. The Program divides the State into six regions: Atlantic Coastal Landscape, Delaware Bay Landscape, Piedmonts Plains Landscape, Pinelands Landscape, Skylands Landscape, and Marine Region. Manchester Township falls entirely within the Pinelands Landscape.

The Pinelands landscape encompasses portions of Ocean, Monmouth, Burlington, Camden, Gloucester, and Atlantic Counties. The Pinelands consists of agricultural lands, coniferous, deciduous and mixed forests, wooded wetlands, scrub and shrub wetlands, and cedar swamps. Within the Manchester Township, there are approximately 43,741 acres of ecologically sensitive habitat.

The program identifies critical habitat areas and ranks them by the presence of priority, threatened or endangered species. The habitat areas are given a Rank between 1 and 5.

Rank 1 is assigned to species-specific habitat patches that meet habitat-specific suitability requirements such as minimum size or core area criteria for endangered, threatened or special concern wildlife species, but that do not intersect with any confirmed occurrences of such species. Rank 1 habitat patches without documented occurrences are not necessarily absent of imperiled or special concern species. Patches with a lack of documented occurrences may not have been systematically

surveyed. Thus, the Rank 1 designation is used for planning purposes, such as targeting areas for future wildlife surveys.

Manchester Township has approximately 852.0 acres of Rank 1 habitat within its borders. The majority of the habitat area is located adjacent to the Ridgeway Branch, Union Branch and the Toms River, in the south east corner of the Township. Additional Rank 1 habitat areas are scattered throughout central portion of the Township.

Rank 3 is assigned to species-specific patches containing one or more occurrences of State threatened species. State threatened species are species which are an indigenous nongame wildlife species of New Jersey designated pursuant to the Endangered and Nongame Species Conservation Act, N.J.S.A.23:2A et. seq., and its implementing rules, N.J.A.C. 7:25-4.17, as most recently amended. Threatened species are generally defined to be species that may become endangered if conditions surrounding them begin or continue to deteriorate. Manchester Township has approximately 5,370.7 acres of Rank 3 habitat.

Within the Rank 3 habitat in the Township, the following species have been located:

- Barred Owl (Aves/State Threatened)
- Dotted Skipper (Insecta)
- Eastern Kingsnake (Reptilia)
- Fowler's Toad (Amphibia)
- Northern Pine Snake (Reptilia / State Threatened)
- Pine Barrens Bluet (Insecta)
- Pine Barrens Tree Frog (Amphibia / State Threatened)
- Two-spotted Skipper (Insecta)

Rank 4 is assigned to species-specific habitat patches with one or more occurrences of State endangered species. State endangered species are species included on the list of endangered species at N.J.A.C. 7:25-4.13 and any species or subspecies of wildlife appearing on any Federal endangered species list. The Endangered and Nongame Species Conservation Act (N.J.S.A. 23:2A et seq.) defines an endangered species (with respect to wildlife) to be a species or subspecies of wildlife whose prospects for survival or recruitment are in jeopardy or are likely within the foreseeable future to become so due to any of the following factors: (1) the destruction, drastic modification, or severe curtailment of its habitat, or (2) its overutilization for scientific, commercial or sporting purposes, or (3) the effect on it of disease, pollution, or predation, or (4) other natural or manmade factors affecting its prospects of survival or recruitment within the State, or (5) any combination of the foregoing factors. The term shall also be deemed to include any species or subspecies of wildlife appearing on any Federal endangered species list.

Manchester has approximately 36,047.3 acres of Rank 4 habitat. The following species have been located:

- American Bittern (Aves / State Endangered)
- Arogos Skipper (Insecta / State Endangered)
- Bald Eagle (Ave / State Endangered)
- Barred Owl (Aves / State Threatened)
- Black-throated Green Warbler (Aves)

The following table gives a breakdown of each of the habitat ranks found in the Township.

NJDEP Landscape Project Habitat Rankings		
Rank	Acres	Percentage
Rank 1: Habitat Specific Requirements	852.0	1.9%
Rank 2: Special Concern	1,271.8	2.9%
Rank 3: State Threatened	5,370.7	12.3%
Rank 4: State Endangered	36,047.3	82.4%
Rank 5: Federal Listed	199.0	0.5%
Total	43,740.8	100.0%

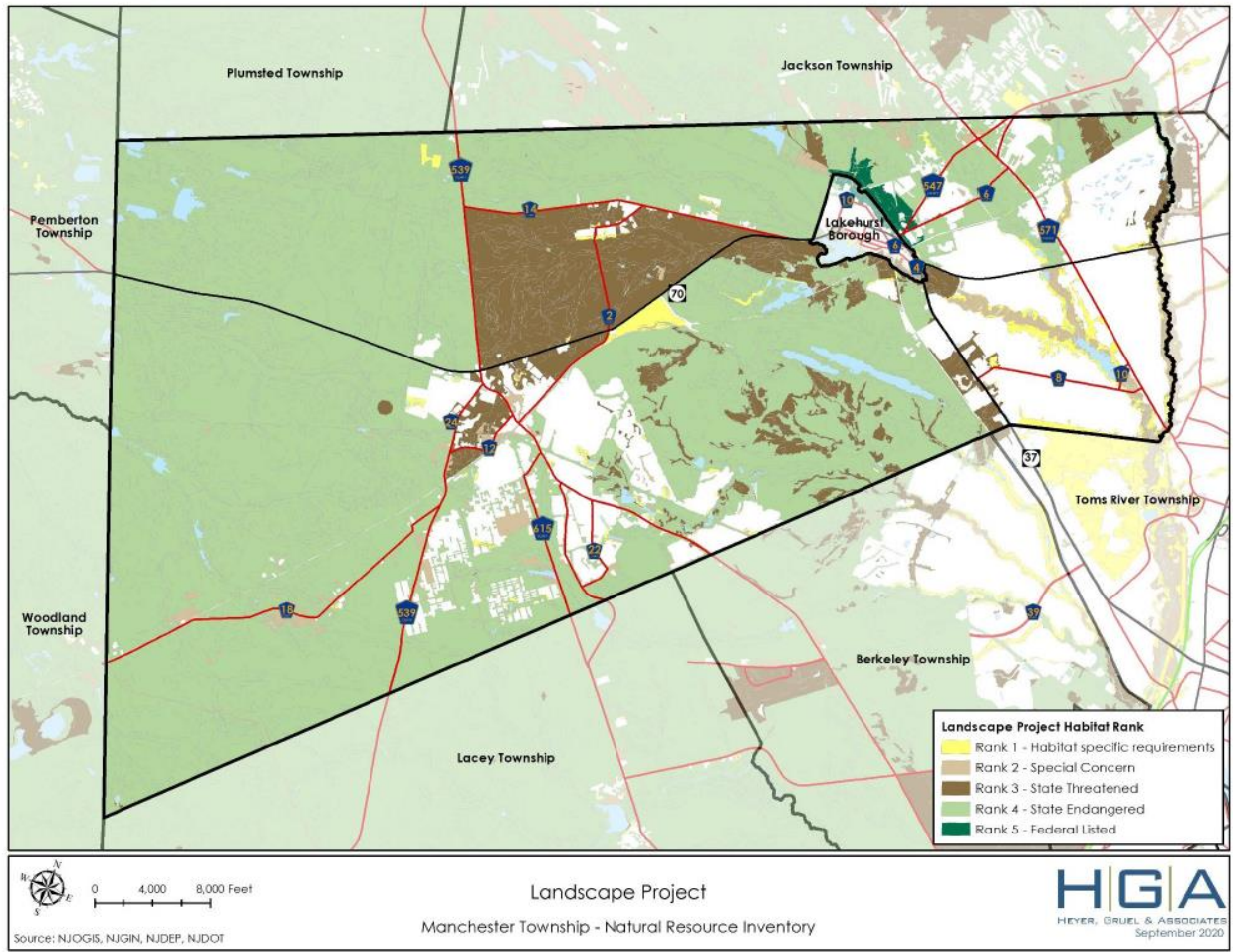

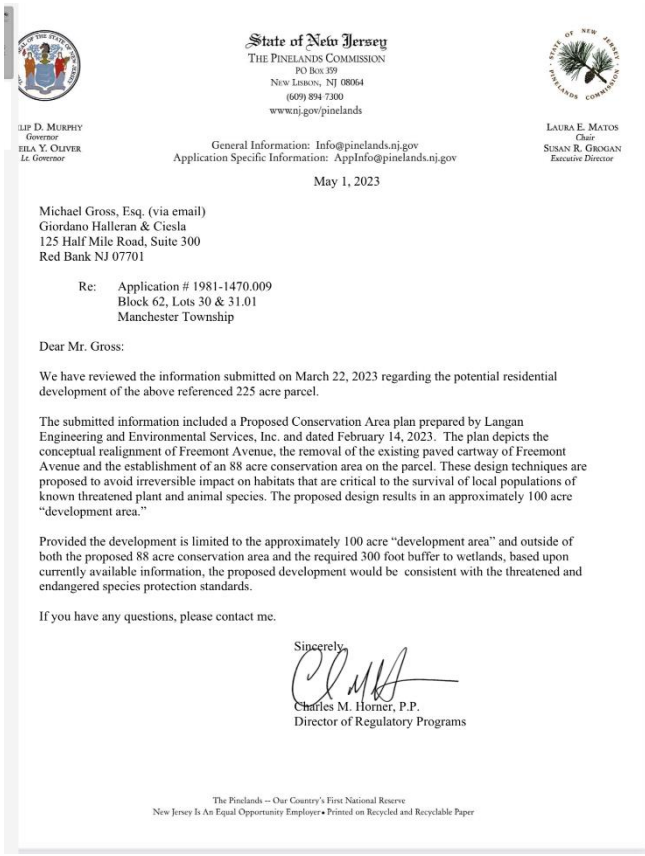

We have a letter from the Pinelands concerning the Conservation Area, which is a bit vague. There is no formal application at the Pinelands yet.

They are building a large warehouse hub in place of the right to build 200-300 senior housing which no one wants. Below are photos of the new plan and an aerial view



Image redacted due to the inclusion of sensitive information regarding the location of threatened and endangered species

Questions from the Environmental Commission at their October 24, 2023 meeting

1. Is this the final plan? What other alternatives did they review?
2. Why did they choose to build on the forested land abutting the tributary of the Toms River that flows to Pine Lake?
3. Why not build on the abandoned mine? This side is the real area-in-need-of-redevelopment, and perhaps a cleanup. It does not meet the goal of protecting the environment in the Master Plan.
4. Why not choose to review an alternative plan. The 100-acre forest contributes to lowering greenhouse gas, has endangered (not just threatened) species on the property, is natural perhaps even the original native growth, and meets the goal of protecting the environment.
5. Can the applicant provide the study that shows there is a regional demand for storage warehouses?
6. Can the applicant explain why there are basins on the property and not green infrastructure as required by the NJ DEP?
7. Can the applicant explain how their proposed stormwater basin will clean the runoff before it goes into the groundwater?
8. Who is going to take care of the trees and the proposed basin?
9. Can the applicant provide the drawing that they use with the Pinelands Commission to discuss the Conservation Area?
10. Will the site have to put up snake fencing?

Manchester Environmental Commission Letterhead

December 5, 2023

Susan R. Grogan, Executive Director
State of New Jersey Pinelands Commission
PO Box 08064
New Lisbon, NJ 08064 via email Susan.Grogan@pinelands.nj.gov

Re: Application # 1981-1470.0009
 Block 62, Lots 30 & 31.01, Manchester Township

Dear Executive Director Grogan,

We are reaching out, on behalf of the Manchester Township Environmental Commission, to request a full and comprehensive environmental study for pine snakes and potentially other “rare species” within an environmentally sensitive area.

The property is recognized for its unique biodiversity and is home to a population of pine snakes (*Pituophis melanoleucus*), a species that plays a crucial role in maintaining ecological balance. Pine snakes are listed as a species of concern, and their presence in the aforementioned area raises questions about the potential impact of human activities on their long-term habitat.

Several factors contribute to the urgency of conducting an environmental study in this region. These include, but are not limited to, ongoing development projects, changes in land use, and potential threats to the pine snake population. The purpose of the study is to assess the current status of the pine snake population, identify their habitats and breeding grounds, and evaluate any potential threats or disruptions to their ecosystem. As of right now the building on this specific site is projected to be in the forested area rather than the deforested area, which is a major concern of the Manchester Township Environmental Commission. This concern is coupled with the necessary breeding areas of the pine snake.

An in-depth environmental study will provide valuable insights into the ecological health of the area and guide future planning and development decisions to ensure the preservation of this vital habitat. The study should be conducted by qualified environmental experts with expertise in herpetology and ecology, and it should encompass a thorough examination of the potential impacts of proposed and existing projects on the pine snake population. The study should be for a full season in 2024 and include drift fences and radio-tracking of captured rare reptile species.

We understand the importance of balancing environmental conservation with responsible development, and I believe that a comprehensive environmental study will serve as a foundation for informed decision-making. We kindly request that the New Jersey Pinelands Commission allocates resources and coordinates with relevant environmental agencies to initiate this study promptly.

Sincerely Yours,

Gabrielle Fox

Gabrielle Fox, Chair

Karen Argenti

Karen Argenti, Vice Chair

c. Bethany Williams

Did you know that the temperature of the Equator is always 80 degrees? Sometimes it goes to 86. Of course, it is surrounded by the rain forest and has 140 inches of rain per year. While we are facing the risk of a three-day 100-degree heat wave many times in a summer, the Equator never gets out of the 80's.

We now experience the new normal of more intense weather & catastrophic flooding. No accident of Nature; increased flooding and storm damage are driven by the greater heat load carried by the atmosphere, the work of human hands and industry's global scale. This is the most serious problem we face—an emergency extending far beyond the capacity of present infrastructure.

Ecological development can make a difference to better hold water with enhanced soils sustaining denser, more vibrant vegetation, and establishing living baselines for existing carbon sequestration using Nature as the measure. You see, **Concrete and iron** used to produce housing, commercial or industrial structures create large quantities of CO₂ during manufacturing, exacerbating the “urban heat island effect” when built. **Meadows, trees, and wetland restorations connecting green infrastructure & water together** not only cool the air but also creates a sink for this carbon. It is important to build right, protecting the future.

I come before you tonight to discuss the AINR on B62 L30 & 31.01. I see that the planning board has reviewed the proposed plan to build where there is a forest and not in the area that was in need of redevelopment. The Environmental Commission has discussed this project at several of our meetings and find that we do not have enough information currently.

1. The applicant noted the presence of the pine snake and other endangered species, but fails to identify the location for the nests of the habitat (page 14 of July 2022 Study). Because of this, we have requested that the Pinelands Commission preform a study.

“The property is recognized for its unique biodiversity and is home to a population of pine snakes (*Pituophis melanoleucus*), a species that plays a crucial role in maintaining ecological balance. ...

Several factors contribute to the urgency of conducting an environmental study in this region. These include, but are not limited to, ongoing development projects, changes in land use, and potential threats to the pine snake population. The purpose of the study is to assess the current status of the pine snake population, identify their habitats and breeding grounds, and evaluate any potential threats or disruptions to their ecosystem. ...

..... The study should be conducted by qualified environmental experts with expertise in herpetology and ecology, and it should encompass a thorough examination of the potential impacts of proposed and existing projects on the pine snake population. The study should be for a full season in 2024 and include drift fences and radio-tracking of captured rare reptile species.”

2. Application into the Pinelands Commission was submitted the Tuesday after Thanksgiving.

3. The Wetland LOI was just submitted to neighbors.

Approving this project is premature. There is not enough information to decide. Please vote NO.

"There is almost certainly critical winter hibernation (denning) habitat in the forest that is threatened with clearing, and only a proper pine snake study with drift fences and radio-telemetry can reveal the actual critical habitat situation. If development proceeds without such a study, *habitat critical to the survival of a local population of a threatened species would likely be destroyed.*" -Emile DeVito, Ph.D., Manager of Science, NJ Conservation Foundation

12/18/23

AN ORDINANCE OF THE TOWNSHIP OF MANCHESTER, COUNTY OF OCEAN, STATE OF NEW JERSEY, APPROVING THE REDEVELOPMENT PLAN FOR BLOCK 62, LOTS 30 AND 31.01

WHEREAS, the Governing Body of the Township of Manchester, County of Ocean, New Jersey ("Governing Body") has designated an area known as Block 62, Lots 30 and 31.01 on Township of Manchester Tax Maps including rights of way (the "Redevelopment Area"), as an area in need of redevelopment; and

WHEREAS, the Governing Body intends to adopt a redevelopment plan to provide specific provisions for the redevelopment of the Redevelopment Area; and

WHEREAS, the Governing Body has referred the proposed Redevelopment Plan ("Redevelopment Plan") to the Township of Manchester Planning Board for review and recommendation; and

WHEREAS, the Governing Body has received the recommendation of the Planning Board and has conducted a public hearing on the proposed Redevelopment Plan; and

NOW, THEREFORE, BE IT ORDAINED by the Governing Body of the Township of Manchester, County of Ocean, State of New Jersey, that:

SECTION 1. Pursuant to the Authority granted to the Governing Body by N.J.S.A. 40A:12A-7, the Redevelopment Plan, dated October 9, 2023, prepared by Morgan Engineering LLC is on file at the Office of the Township Clerk and can be reviewed by the public during normal business hours.

SECTION 2. Pursuant to the provisions of N.J.S.A. 40A:12-7c, the Redevelopment Plan shall constitute an overlay zoning district within the redevelopment area. The official Township Zoning Map shall be amended to henceforth coincide with the Redevelopment Plan.

SECTION 3. An Ordinance or parts of Ordinances inconsistent with the provisions of this Ordinance are hereby repealed as to such inconsistency only.

SECTION 4. If any provision of this Ordinance is declared invalid, such invalidity shall not affect the other provisions of this Ordinance. Furthermore, the other provisions of this Ordinance are deemed to be severable and remain in full force and effect.

SECTION 5. This Ordinance shall take effect after final approval and publication according to law.

NOTICE

NOTICE IS HEREBY GIVEN that the foregoing Ordinance was introduced and passed by the Township Council of the Township of Manchester on first reading at a meeting held on the **10th day of October 2023 at 6:00 p.m.** The Ordinance will be considered for second and final reading at a meeting of the Township Council which is scheduled for **18th day of December, 2023 at 6:00 p.m.** or as soon thereafter as the matter may be reached, at the Municipal Building located at 1 Colonial Drive, Manchester, New Jersey 08759, at which time the public is invited to ask questions, raise objections, or provide public comment with regard to the proposed adoption of this Ordinance.

Teri Giercyk, RMC/CMC
Municipal Clerk

PUBLIC NOTICE

Pursuant to N.J.A.C. 7:50-3.45, the New Jersey Pinelands Commission will conduct a public hearing on Manchester Township Ordinance 24-02. Comments are being sought on whether the ordinance is in conformance with the Pinelands Comprehensive Management Plan (CMP).

Ordinance 24-02 adopts the Redevelopment Plan for Block 62, Lots 30 & 31.01, dated December 28, 2024. The redevelopment area contains two lots spanning approximately 224 acres. The redevelopment area is currently vacant, but was the site of a former resource extraction operation. It is located within the Township's Pinelands Environmental Development-1 (PED-1) District. The PED-1 District is located within a Pinelands Regional Growth Area.

The Redevelopment Plan permits light industrial uses, warehouses, distribution centers, wholesaling, flex space, indoor recreation, scientific or research facilities, business or professional offices and indoor agriculture. The Redevelopment Plan conditionally permits online commercial businesses as well as outdoor recreation. The plan includes various development standards related to lot area and bulk, vegetative buffering, parking, design, lighting, and signage. Lastly, any non-residential development permitted under the redevelopment plan is required to redeem Pinelands Development Credits (PDCs) at a rate of one quarter (1/4) PDC for every 11,500 square feet of gross floor area within principal use and conditional use buildings, except for conditionally permitted outdoor recreation uses. Conditionally permitted outdoor recreation uses are required to redeem PDCs at a rate of 1/4 PDC for every 1.34 acres.

As such, Ordinance 24-02 directly relates to CMP standards and must be formally reviewed and approved by the Pinelands Commission before it may take effect.

The hearing will be conducted remotely and broadcast live on the Commission's YouTube channel at the following time:

Date: Wednesday, April 3, 2024
Time: 9:30 a.m.

To view the hearing, visit <https://www.youtube.com/live/aXJigPbLakc?feature=shared>. The public may provide comment during the hearing by calling 929-205-6099 and using Meeting ID: 811 9421 4707.

The public may submit written comment by email (preferred), regular mail, or facsimile by Friday, April 5, 2024, to:

Planning Office
Pinelands Commission
PO Box 359
New Lisbon, NJ 08064
Facsimile: (609) 894-7330
Email: planning@pinelands.nj.gov or through the Commission's website at <https://www.nj.gov/pinelands/home/contact/public.shtml>

The documents and supporting materials are available electronically for public inspection on the Commission's website or upon request by contacting the Pinelands Commission at planning@pinelands.nj.gov.



PINELANDS
PRESERVATION
ALLIANCE

Bishop Farmstead
17 Pemberton Rd
Southampton NJ 08088
609-858-8860

ppa@pinelandsalliance.org
www.pinelandsalliance.org

March 25, 2024

Jacquelyn A. Suárez
State of NJ Department of Community Affairs
101 South Broad Street
PO Box 800
Trenton, NJ 08625-0800

Re: Review of Ordinance 24-02 Adopting the Redevelopment Plan for Block 62, Lots 30 & 31.01 (non-condemnation)

Dear Acting Commissioner Suárez,

We request that the Department of Community Affairs review the Manchester Township Redevelopment Plan adopted through ordinance 24-02 and not grant approval of the Township's determination that this area is in need of redevelopment. This is another example of the perverse way that redevelopment provisions of the municipal land use law are being abused. Allowing the 'redevelopment' of undeveloped land undermines the intention of the law to incentivize the revitalization of derelict land that is truly in need of redevelopment. This particular plan for 224 acres of Pinelands land epitomizes the problems with our current redevelopment laws, as the northern portion of the property that was previously disturbed as a resource extraction site (lot 31.01) will be preserved, while the untouched forested portion of the site (primarily lot 30) will be 'redeveloped'. This plan to develop via deforestation in lieu of actual redevelopment is a farcical exploitation of New Jersey's laws. The DCA should not approve this plan as redevelopment, and should close the loopholes that allow the widespread abuse of redevelopment laws in New Jersey.

At the very least, this plan should not be granted the benefits that accompany a redevelopment designation, because developers should not be given incentives to destroy undeveloped forests. The developer was likely advised to avoid the mined area altogether to simplify the approval process. There are threatened & endangered species concerns associated with the former resource extraction site: the patchwork of open fields, sandlots, and trees has created attractive nesting habitat for pine snakes. However, a thorough enough study would likely reveal the intact upland forest that is adjacent to the former mines to also be critical habitat for these snakes. Focusing development on the forest ignores

the critical habitat value for hibernation that the adjoining upland mature forest also provides for the population of the threatened snake species. A thorough study of this population has yet to be done. The upland forest should not be sacrificed to compensate for the more apparent limitations of the former extraction site.

This redevelopment plan is part of a troubling trend in southern New Jersey, whereby redevelopment is often used to target undeveloped forests, while truly derelict properties sit unused nearby. Please revisit our October 10, 2023 letter concerning a similar abuse of the redevelopment law in Pemberton Township. The current manifestation of the law is just a giveaway to developers that sacrifices both the environment and smart growth principles. Please change the redevelopment law to restore its originally intended function to revitalize New Jersey communities, starting with the revocation of Manchester Township Ordinance 24-02.

Sincerely,

Heidi Yeh, Ph.D.
Pinelands Preservation Alliance

Emile DeVito, Ph.D.
New Jersey Conservation Foundation

From: Emile DeVito <emile@njconservation.org>
Sent: Wednesday, April 3, 2024 2:12 PM
To: Planning, PC [PINELANDS] <planning@pinelands.nj.gov>
Subject: [EXTERNAL] Comments on Manchester Township Ordinance 24-02

Highly Likely Pine Snake Critical Habitat for Winter Hibernacula at the proposed Manchester Twp. site - Block 62, lots 30 and 31.01.

The entire area within the yellow highlight on the map below is a generally south-facing slope - high in the uplands, with deciduous canopy being prominent. Thus, it has excellent *insolation* for warmth during late fall, winter, and early spring, making it an excellent site for hibernacula for northern pine snake, since pine snakes emerge on warm days and bask at the surface to fight bacteria and pathogens. While this is the most likely area to contain pine snake hibernacula, *hibernacula could also occur anywhere in this entire forest patch - in any upland forest habitat that is well-above the high water table associated with nearby wetlands and the stream corridor.*

With a well-designed survey, pine snake adults should be captured using an extensive network of drift fences, and neonates captured via corrals around nest sites, and all pine snakes captured must be radio-tracked. Neonates can be radio-tracked from hatching in early September to find their winter hibernacula, which are usually different than adults and fairly close to nest sites. Winter corrals must be erected around neonate hibernacula so that neonates can be recovered in the spring upon emergence, since their small transmitters will have run out of power and must be removed. Adults must be captured in the network of drift fence traps and tracked through *at least 2 autumns*, because they often use different hibernacula in successive years. Unless this is done properly, it is impossible to determine critical habitat associated with winter hibernacula.

All current published research and ongoing Pinelands Commission staff research points to the necessity for such an intensive study to determine critical habitat. Any study short of this protocol would be irresponsible, as a proper picture of critical habitat for northern pine snake could not be obtained.

Respectfully submitted,
Emile DeVito, Ph.D., New Jersey Conservation Foundation

