

# NEW JERSEY

0000 F R-175, -  
STATE LIBRARY  
LAW DIVISION  
PO BOX 1898  
TRENTON, NJ 08625

# REGISTER

## IN THIS ISSUE— “INDEX OF PROPOSED RULES”

VOLUME 14 NUMBER 20  
October 18, 1982 Indexed 14 N.J.R. 1125-1180  
(Includes rules filed through October 1, 1982)

*The New Jersey Register supplements the New Jersey Administrative Code. See the Index of Adopted Rules on Page 1105 of the October 4 issue for the Registers that should be retained as an update to the Administrative Code.*

## TABLE OF RULES IN THIS ISSUE

### RULE PROPOSALS

CIVIL SERVICE	
Overtime Committee Rules .....	1126(a)
COMMUNITY AFFAIRS	
Uniform Construction Code: Periodic inspection fees ..	1129(a)
ENVIRONMENTAL PROTECTION	
Coastal resource and development .....	1129(b)
Floodway delineations in Somerset-Union counties ..	1131(a)
Floodway delineations in Hunterdon County .....	1131(b)
Floodway delineations in Mercer County .....	1132(a)
Floodway delineations in Mullica River Basin .....	1133(a)
Floodway delineations in Monmouth County .....	1134(a)
Construction of wastewater treatment facilities .....	1135(a)
Water quality: Underground injection control .....	1136(a)
Hazardous waste management .....	1137(a)
Hazardous waste management .....	1138(a)
HIGHER EDUCATION	
State college auxiliary organizations .....	1141(a)
HUMAN SERVICES	
Pharmacy Manual: Appendices B, C, and D .....	1142(a)
Second opinion requirement on certain surgery .....	1143(a)
Local assistance board appointments .....	1144(a)
LABOR	
Wage and hour: “Administrative” defined .....	1145(a)
LAW AND PUBLIC SAFETY	
Attendance fee for driver improvement school .....	1145(b)

Restoration fee for motor vehicle license .....	1146(a)
Thoroughbred rules .....	1146(b)
Harness racing: Vaccination; respiratory bleeding ....	1147(a)
PUBLIC UTILITIES	
Board proceedings and ex parte communications .....	1148(a)
STATE	
Voter registration: Timely filing .....	1148(b)
TREASURY—GENERAL	
Alternate Benefit Program: Salary agreements and deductions .....	1149(a)
PERS: Ineligibility; contributory insurance rates; interfund transfers .....	1150(a)
PERS: Beneficiary designation; purchases .....	1151(a)
TREASURY—TAXATION	
Pre-audit payment of inheritance tax .....	1153(a)

### RULE ADOPTIONS

AGRICULTURE	
Brucellosis testing for intrastate movement .....	1154(a)
EDUCATION	
Vocational education safety standards .....	1154(b)
ENVIRONMENTAL PROTECTION	
Correction: Coastal resources and development .....	1155(a)

(Continued on Back Cover)

# RULE PROPOSALS

## CIVIL SERVICE

(a)

### CIVIL SERVICE

#### Overtime Committee Rules

**Proposed New Rule: N.J.A.C. 4:6**  
**Proposed Repeal: N.J.A.C. 4:6**

Authorized By: Overtime Committee (President of the Civil Service Commission, State Treasurer and Director of the Division of Budget and Accounting), Peter J. Calderone, Director, Division of Administrative Practices and Labor Relations.

Authority: N.J.S.A. 52:14-17.13 and -17.14.

**Interested persons** may submit in writing, data, views or arguments relevant to the proposal on or before November 17, 1982. These submissions, and any inquiries about submissions and responses, should be addressed to:

Peter J. Calderone, Director  
 Division of Administrative  
 Practices and Labor Relations  
 CN 312  
 Trenton, NJ 08625

The Overtime Committee thereafter may adopt this proposal without further notice (see: N.J.A.C. 1:30-3.5). The adoption becomes effective upon publication in the Register of a notice of adoption.

This proposal is known as PRN 1982-400.

The agency proposal follows:

#### Summary

The Overtime Committee rules contained in N.J.A.C. 4:6 are being repealed in their entirety and new rules are being proposed since the revisions are too extensive for the amendment process. The proposed rules conform to rule format standards and are written

in plain English. Several substantive changes have been made to conform to statutory language and incorporate long standing practice.

The practices which have been incorporated into the proposed rules are: the Overtime Committee may approve alternate workweeks for overtime purposes administratively (N.J.A.C. 4:6-2.1); part-time employees are granted overtime compensation for work in excess of the workweek established for their title (N.J.A.C. 4:6-3.4); casual employees are not eligible for overtime compensation (N.J.A.C. 4:6-3.5 and 6.6); hour for hour compensation may be granted to eligible employees for time spent in training beyond normal work hours (N.J.A.C. 4:6-5.2); overtime compensation shall be granted for travel related to overtime assignments while hour for hour compensation may be granted for travel related to normal work assignments (N.J.A.C. 4:6-5.3); in exceptional emergencies, overtime compensation may be granted to certain NL (non-limited) employees and the rule concerning compensable work may be suspended (N.J.A.C. 4:6-5.5); and NL employees may be granted hour for hour time off for holiday work (N.J.A.C. 4:6-6.3).

Clarifications which have been made are: "comparable amounts of time off" means time off to a maximum of hour for hour (N.J.A.C. 4:6-3.2); once an employee is eligible for overtime in a workweek, additional one-half hour units of overtime in that week will be credited towards overtime compensation (N.J.A.C. 4:6-4.1); and an employee may not be required to take time off without pay during a workweek to reduce hours of compensable overtime (N.J.A.C. 4:6-4.3).

Summer hours (N.J.A.C. 4:6-5.5) have been deleted since this practice no longer exists. Classification related matters (N.J.A.C. 4:6-4.1 et seq) are not repeated since these items are not regulated by the Overtime Committee.

#### Social Impact

The proposed new Overtime Committee rules will have minimal social impact since they generally are a codification of existing law, rule and administrative practice. The proposed rules will, however, facilitate easier and more comprehensive understanding of how State employees will be compensated in overtime situations.

#### Economic Impact

The proposed new Overtime Committee rules will have minimal economic impact since they generally are a codification of existing law, rule and administrative practice.

## NEW JERSEY REGISTER

The official publication containing notices of proposed rules and rules adopted by State agencies pursuant to the New Jersey Constitution, Art. V, Sec. IV, Para. 6 and the Administrative Procedure Act, N.J.S.A. 52:14B-1 et seq. Issued monthly since September 1969, and twice-monthly since November 1981.

Material published in the New Jersey Register is the property of the State of New Jersey. However, it may be copied, reproduced or republished by any person for any purpose whatsoever without permission, providing that no such reproduction or republication shall bear the title "New Jersey Register" or "Official Rules Publication" without the written permission of the Director, Office of Administrative Law.

The New Jersey Register (USPS 442-950) is published the first and third Monday of each month by Administrative Publications of the Office of Administrative Law, CN 301, Trenton, New Jersey 08625. Telephone: (609) 292-6060. Subscriptions, payable in advance, are one year, \$40 (\$75 by First Class Mail); back issues when available, \$3.50 each. Make checks payable to Administrative Publications.

POSTMASTER: Send address changes to: New Jersey Register, CN 301, Trenton, New Jersey 08625. Second Class Postage paid at Trenton, New Jersey and additional mailing offices.

*The NEW JERSEY ADMINISTRATIVE CODE is published on a continuing basis by Administrative Publications of the Office of Administrative Law. Subscription rates for this 31-volume, regularly updated set of all State administrative rules are available on request. The Code is sold either in the full set or in one to three volumes depending on the Department coverage desired.*

**Full text** of the proposal follows (the text proposed for repeal may be found in the Civil Service Manual at N.J.A.C. 4:6).

**CHAPTER 6  
OVERTIME COMMITTEE RULES**

**SUBCHAPTER 1. AUTHORITY AND PURPOSE**

**4:6-1.1 Authority**

The Overtime Committee is composed of the State Treasurer, the President of the Civil Service Commission and the Director of the Division of Budget and Accounting in the Department of Treasury. The Committee shall adopt rules regulating overtime compensation for State employees (see N.J.S.A. 52:14-17.13 and 17.14).

**4:6-1.2 Purpose**

The purpose of the Overtime Committee is to establish eligibility for overtime compensation and insure the equitable application of the statutory overtime provisions.

**SUBCHAPTER 2. DEFINITIONS**

**4:6-2.1 Words and phrases defined**

“Base salary” means the employee’s rate of pay exclusive of any additional payments or allowances.

“Casual employee” means an employee appointed pursuant to a personnel action request for special projects, peak workloads or other operational necessities where the work period is intermittent, irregular or of short duration not exceeding six months within a one year period of initial date of appointment.

“Fixed workweek title” means a title specified in the State Compensation Plan as having a 35 or 40 hour workweek. Such titles have regular work hours.

“Holiday” means a legal holiday or a special holiday declared by the Governor.

“Non-limited (NL) title” means a title specified in the State compensation plan as having an NL or NL4 workweek. Such titles have irregular or variable work hours.

“Overtime compensation” means cash compensation at a rate representing 1 1/2 times the employee’s hourly rate of base salary or compensatory time off at the rate of 1 1/2 hours for each hour worked beyond the normal workweek.

“Part-time employee” means an employee who works a portion of the time specified for a fixed workweek title and is paid at the hourly rate of the annual base salary for the title.

“Seven day coverage position” means a position assigned to an area where work coverage is required on a seven day basis throughout the year.

“Workweek” means the period beginning 12:01 A.M. Saturday and ending midnight the following Friday except in those instances where the Overtime Committee has approved an alternate workweek for overtime purposes for employees engaged in seven day operations.

**SUBCHAPTER 3. ELIGIBILITY**

**4:6-3.1 Fixed workweek titles**

Employees in fixed workweek titles shall be eligible for overtime compensation for time worked in excess of the normal workweek.

**4:6-3.2 Non-limited (NL) titles**

Employees in non-limited (NL) titles shall not be eligible for overtime compensation. Employees in this category may, at the discretion of the appointing authority, be compensated for unusual work time requirements through either a provision for flexible work time patterns or a grant of comparable amounts of time off to a maximum of one hour for each hour of unusual work time. They shall have no claim or entitlement to cash compensation.

**4:6-3.3 State Police**

The Overtime Committee may, upon the request of the Office of Employee Relations, authorize overtime payments for State Police law enforcement officers.

**4:6-3.4 Part-time employees**

Part-time employees shall be eligible for overtime compensation only when they work beyond the normal workweek established for full-time employees in their titles.

**4:6-3.5 Casual employees**

Casual employees shall not be eligible for overtime compensation.

**SUBCHAPTER 4. CONDITIONS FOR AWARDED OVERTIME COMPENSATION**

**4:6-4.1 Compensable overtime**

(a) An employee shall only be eligible for overtime compensation when:

1. S/he is in pay status for the full number of hours in his/her normal workweek; and

2. S/he works at least one hour beyond the normal workweek.

(b) Once an employee is eligible for overtime compensation in a workweek, additional overtime in that workweek shall be credited in units of one-half hour.

(c) Work credited toward overtime compensation must represent one-half hour units of continuous work beyond a normal work day.

**4:6-4.2 Rate of cash compensation**

Cash compensation for overtime work shall be at a rate representing 1 1/2 times an hourly proration of an employee’s base annual salary. An overtime rate conversion table shall be published with the State Compensation Plan.

**4:6-4.3 Reduction of compensable overtime**

An appointing authority shall not require an employee to take time off without pay during a workweek to reduce the number of hours of compensable overtime for that week.

**4:6-4.4 Compensable work**

To be eligible for overtime compensation, work must be covered by the job specification for the employee’s title except as provided in N.J.A.C. 4:6-5.5(a)2.

**SUBCHAPTER 5. SPECIAL CIRCUMSTANCES**

**4:6-5.1 On call situations**

Employees in fixed workweek titles who are required either to live on or be near the premises of their work station or to be on call for emergency situations beyond their usual work hours shall be eligible for overtime compensation only for the time spent in the actual performance of work duties.

**4:6-5.2 Training**

(a) Employees shall not be eligible for overtime compensation for time spent beyond their normal work hours while in training. However, if employees in fixed workweek titles are mandated by an appointing authority to attend training programs and actual formal training and/or related travel extends beyond the normal work hours, the appointing authority may, at its discretion, authorize compensation for the additional time to a maximum rate of hour for hour. The additional compensation may be in the form of cash or time off.

**4:6-5.3 Travel**

(a) Employees shall be eligible for overtime compensation for travel beyond the normal work hours when it is related to assignments for which overtime compensation is authorized and the assignments are contiguous to the normal work day. Normal commutation time shall not be included.

(b) Employees shall not be eligible for overtime compensation for travel to or from work assignments performed during normal work hours. An appointing authority, after deducting normal commutation time, may authorize compensation for the additional time spent in travel by employees in fixed workweek titles to a maximum rate of hour for hour. The additional compensation may be in the form of cash or time off.

#### 4:6-5.4 Overlap shift security time

Department of Corrections personnel in fixed workweek titles who have custodial responsibility during their full shift and must be on duty for an additional period of time each day while the counting of inmates is verified by the succeeding shift shall be entitled to overtime compensation for this additional time. The provisions of N.J.A.C. 4:6-4.1 shall not apply in this situation.

#### 4:6-5.5 Exceptional emergencies

(a) When an agency head declares that s/he is faced with an exceptional emergency involving a critical service disruption that poses a danger to health or safety, s/he may authorize:

1. Overtime compensation for non-limited (NL) employees in titles with established salary ranges below range 35 performing emergency related work. For these circumstances only, employees in non-limited (NL) titles shall be deemed to have a 40 hour workweek.

2. Exceptions to N.J.A.C. 4:6-4.4.

(b) An agency head shall file with the Overtime Committee (c/o President, Civil Service Commission) two reports concerning an exceptional emergency as follows:

1. Within seven calendar days of the declaration of the exceptional emergency, a fully detailed justification for the declaration. The report shall describe the critical services which could have been or were disrupted and what dangers were posed to health or safety.

2. Within 30 calendar days of the conclusion of the exceptional emergency, a list of the names, titles and hours of work designation of employees who performed emergency related work on an overtime basis. The report shall also include the number of hours of emergency related overtime work performed by each employee.

(c) These provisions shall not apply to work performed beyond the normal work hours on emergency maintenance, construction, snow removal or other related work in situations which constitute unreasonable safety hazards to the public, employees, other persons or property of the State. The Civil Service Commission shall establish special project rates for these circumstances.

### SUBCHAPTER 6. HOLIDAY PAY

#### 4:6-6.1 Work on a holiday

Work performed on a holiday shall be treated as work in excess of the regular workweek. Therefore, employees in titles eligible for overtime compensation shall be entitled to overtime compensation for holiday work even though they may not be paid for a full workweek.

#### 4:6-6.2 Fixed workweek titles

Full-time and part-time employees in fixed workweek titles shall be entitled to overtime compensation in addition to their regular rate of compensation for all work performed on a holiday except as provided in N.J.A.C. 4:6-6.5.

#### 4:6-6.3 Non-limited (NL) titles

Employees in non-limited (NL) titles are not entitled to overtime compensation for work performed on a holiday. However, those in titles below that of agency head may, at the discretion of the appointing authority, be granted comparable time off to a maximum of hour for hour for such work in addition to their regular rate of compensation.

#### 4:6-6.4 Seven day coverage positions

(a) The following shall govern overtime compensation for full-time and part-time employees in fixed workweek titles who are employed in a seven day coverage operation:

1. If a holiday occurs on a regular day of an employee and s/he works, the employee is entitled to overtime compensation for all work performed on the holiday in addition to the regular rate of compensation.

2. If a holiday occurs on a regular day of an employee, s/he shall be given an additional day off in the same workweek. If, as the result of an emergency, the employee is required to work on the additional day, s/he shall be entitled to overtime compensation for all work performed on the additional day.

3. If a holiday occurs on a regular workday of an employee and the employee does not report for duty, s/he is only entitled to receive regular base pay, if otherwise eligible, for a sick, vacation or administrative leave day.

#### 4:6-6.5 Personal preference days

A part-time or full-time employee in a fixed workweek title and an appointing authority may agree that the employee shall work on a holiday in exchange for a specified day of personal preference off. If the employee is required to work on the specified personal preference day, s/he shall be entitled to overtime compensation for all hours worked on the personal preference day as if that day were the holiday.

#### 4:6-6.6 Casual employees

(a) Casual employees shall not be entitled to overtime compensation for work performed on a holiday.

(b) Casual employees shall not be entitled to any form of compensation for a holiday not worked.

### SUBCHAPTER 7. APPOINTING AUTHORITY RESPONSIBILITIES

#### 4:6-7.1 Development of regulations

(a) The appointing authority shall develop regulations for administering overtime that are consistent with this chapter and at a minimum provide for:

1. Procedures for written authorization and approval by the appointing authority or his/her designee in advance of overtime to be worked. Whenever circumstances are such that prior authorization is not possible, the overtime must be authorized in writing immediately thereafter;

2. Records of approved overtime requests and work accomplished;

3. Systems for continuous and periodic review of overtime requirements with a view toward devising methods to accomplish the work during regular work time; and

4. Procedures for departmental directors, bureau chiefs and supervisors to follow in the authorization of either compensatory time or cash payment for overtime.

(b) A copy of each department's procedures and written interpretations and any subsequent changes are to be filed with the Overtime Committee (c/o President, Civil Service Commission) and approved prior to promulgation.

#### 4:6-7.2 Reporting requirements

For budget requests, the appointing authority shall provide an annual summary to include the extent and justification for overtime required during the past fiscal year, current fiscal year and the extent and justification of anticipated overtime during the next fiscal year. The latter shall be supported by a description of the work programs to be accomplished, the amount of hours and money involved, the circumstances dictating that it be overtime, and alternatives that would permit accomplishment of the overtime work on regular time. The instructions for the above shall be included in the "Manual for Preparation of Budget Request" which

## PROPOSALS

is published and distributed to all State Agencies by the Division of Budget and Accounting in the Department of Treasury. The appointing authority shall file a copy of this summary with the Overtime Committee (c/o President, Civil Service Commission).

### 4:6-7.3 Records

Upon demand, the appointing authority shall make available to the Overtime Committee or its representative all records and accounts of overtime work at the time(s) and location(s) specified.

### 4:6-7.4 Payroll procedures

Procedures for payment of compensable overtime will be published as amendments to the Payroll Manual.

## COMMUNITY AFFAIRS

### (a)

### DIVISION OF HOUSING

#### Uniform Construction Code Departmental Periodic Reinspection Fees

#### Proposed Amendment: N.J.A.C. 5:23-4.20

Authorized By: John P. Renna, Commissioner, Department of Community Affairs.

Authority: N.J.S.A. 52:27D-124.

**Interested persons** may submit in writing, data, views or arguments relevant to the proposal on or before November 17, 1982. These submissions, and any inquiries about submissions and responses, should be addressed to:

Michael L. Ticktin, Esq.  
Administrative Practice Officer  
Division of Housing  
CN 804  
Trenton, NJ 08625

The Department of Community Affairs thereafter may adopt this proposal without further notice (see: N.J.A.C. 1:30-3.5). The adoption becomes effective upon publication in the Register of a notice of adoption.

This proposal is known as PRN 1982-398.

The agency proposal follows:

#### Summary

Inspection fees are being established for those inspections performed by the Department that are required by this chapter to be performed at frequent intervals. These fees are for elevators, escalators and moving walks, dumbwaiters, hazardous uses and place of assembly, cross connections and backflow preventers subject to testing and sprinklers. The increases are necessary in order to make the department's enforcing agency function self-supporting. The Department believes that it is fair and reasonable that this function be self-supporting because local Code enforcement by the Department under the Uniform Construction Code Act only exists where a municipality has requested the Department to assume that function in substitution for local enforcement, which is locally-supported in those municipalities that enforce the Code themselves. The rest of the State's taxpayers should not have to subsidize any municipality that chooses not to enforce the Code with its own employees. The Department does not expect that the increases in the fees will be so significant as to have a material adverse effect upon builders or property owners.

## ENVIRONMENTAL PROTECTION

### Social Impact

By charging a fee that reasonably reflects the cost to the Department performing the inspections, the Department will not have to pass this cost on to other payers of fees or the public through the General State Treasury.

### Economic Impact

There will be an economic impact on property owners who have their premises inspected and who will be required to pay the appropriate fees. The State will gain an economic benefit since the fees charged will make the inspection program self-supporting thereby preventing the expenditure of State funds.

**Full text** of the proposal follows (additions indicated in boldface thus).

### 5:23-4.20 Department fees

(a)-(b) (No change.)

(c) Departmental (enforcing agency) fees:

1.-9, (No change.)

**10. Fees for the periodic reinspection by the Department of equipment and facilities granted a certificate of approval for a specified duration in accordance with N.J.A.C. 5:23-2.23 shall be as follows:**

i. For elevators, escalators and moving walks requiring reinspection every six months, the fee shall be \$30.00.

ii. For dumbwaiters requiring reinspection every 12 months, the fee shall be \$15.00.

iii. For hazardous uses and places of assembly requiring reinspection every three months, the fee shall be \$10.00 for occupancies of up to 12,000 square feet and \$5.00 for each additional 10,000 square feet.

iv. For cross connections and backflow preventers that are subject to testing, requiring reinspection every three months, the fee shall be \$20.00 for each device when they are tested (thrice annually) and \$50.00 for each device when they are broken down and tested (once annually).

v. For sprinklers requiring reinspection every 12 months, the fee shall be \$100.00 for systems of up to 100 sprinkler heads and \$5.00 for each 150 additional sprinkler heads.

## ENVIRONMENTAL PROTECTION

### (b)

### DIVISION OF COASTAL RESOURCES

#### Coastal Resource and Development Policies Limited Growth Area; Low Intensity Development

#### Proposed Amendments: N.J.A.C. 7:7E-5.3, 5.6 and 5.7

Authorized By: Robert E. Hughey, Commissioner,  
Department of Environmental Protection.

Authority: N.J.S.A. 13:1D-9, 13:19-10, 13:9A-2 and  
12:5-3.

DEP Docket No.: 051-82-09.

A **public hearing** concerning this proposal will be held on Tuesday, November 9, 1982 at 1:30 P.M. at:

Labor and Industry Building
Room 702
John Fitch Plaza
Trenton, NJ 08625

For further information, call (609) 292-9762.

Interested persons may submit in writing, data, views or arguments relevant to the proposal on or before November 17, 1982. These submissions, and any inquiries about submissions and responses, should be addressed to:

Allan B. Campbell, Chief
Bureau of Coastal Planning and Development
Division of Coastal Resources
CN 401
Trenton, NJ 08625

The Department of Environmental Protection thereafter may adopt this proposal without further notice (see: N.J.A.C. 1:30-3.5). The adoption becomes effective upon publication in the Register of a notice of adoption.

This proposal is known as PRN 1982-409.

The agency proposal follows:

Summary

The Division of Coastal Resources proposes to amend its rules on Coastal Resource and Development Policies to clarify the circumstances under which large-scale residential developments are acceptable in Limited Growth Regions. This clarification is intended to correct some confusion that has existed concerning the present wording.

Limited Growth Regions are regions which contain large areas of environmentally sensitive land. Generally, only infill development is acceptable in a Limited Growth Region, with the exception of large-scale residential developments, which are defined (at N.J.A.C. 7:7E-7.2(i)) as freestanding, planned developments including at least 500 dwelling units.

Social Impact

This proposed amendment will clarify existing rules. Therefore, no social impact is anticipated.

Economic Impact

No economic impact is anticipated for the same reason that no social impact is anticipated.

Full text of the proposal follows (additions indicated in boldface thus; deletions indicated in brackets [thus]).

7:7E-5.3 Coastal growth rating

(a) Introduction: The coastal zone is classified into 13 different regions on the basis of the varied pattern of existing coastal development and natural and cultural resources. For the regions, DEP uses three broad regional growth strategies:

1.-2. (No change.)

3. Limited Growth Region: This region contains large environmentally sensitive areas. Generally, only infill development is acceptable here[.], with the exception of development which meets the requirements of the Large-Scale Residential Development Policy (N.J.A.C. 7:7E-7.2(i)).

(b)-(o) (No change.)

7:7E-5.6 Definition of acceptable intensity of development

(a)-(c) (No change.)

(d) Low Intensity Development: At this level of development intensity, the existing conditions of the site are not to be disturbed, except for [selective removal of vegetation for agricultural use or maintenance purposes. Also, no grading, paving or structures would be allowed except for agriculture rated use. Typically the landscape of Low Intensity Development areas would be rural,

agricultural, or forest, as shown below in the photomaps. An exception to this general rule is the removal of vegetation for agricultural or silvicultural purposes or for recreational use that does not disturb soils. Unless the vegetation is in a special area, the following figures are applicable.] very low density development compatible with agriculture, forestry and rural residential uses, which meets the following intensity requirements.

Table with 5 columns: Low Intensity Development, Structures and Impervious Paving, Structures and Permeable Paving, Herb and Shrub, Forest. Rows: Maximum, Minimum.

7:7E-5.7 Land Acceptability Tables

(a) (No change.)

(b) Rationale: The Land Acceptability Tables represent a striking of balances between the environmental sensitivity and development potential of sites, and balances among regions, in order to indicate both which land areas are appropriate locations for development and how the design of the development should use the land features of the site.

1.-2. (No change.)

3. Limited Growth Areas (Delaware Bayshore, Mullica-Southern Ocean, Great Egg Harbor River Basin): The general policy in these areas is that conservation is more important than development and environmental sensitivity is therefore weighed more heavily than in other areas. In the Delaware Bayshore, the concern is the conservation of agricultural land. In the Mullica-Southern Ocean and Great Egg Harbor River Basin regions the concern is conservation of the natural environment. The spread of development must, therefore, be highly restricted.

Areas 1 and 2: These areas show moderate intensity development acceptable in sites with high development potential. This allows a limited amount of growth within existing settlements especially where development had leapfrogged in the past leaving pockets of undeveloped land. Moderate intensity development is also acceptable in large-scale residential developments which meet the requirements of the Large-Scale Residential Development Policy (N.J.A.C. 7:7E-7.2(i)).

Areas 3 to 9: In these areas development is restricted in Limited Growth Regions either because the lower development potential implies ribbon or scattered sprawl in conflict with the subregional growth policy, or to conserve the environmentally sensitive areas which are more valuable in Limited Growth Regions than elsewhere.

(c) (No change.)

(a)

**DIVISION OF WATER RESOURCES**

**Flood Hazard Area Delineations  
Flood Delineations of Streams in North  
Plainfield and Somerville Boroughs,  
Somerset County and Plainfield, Union  
County**

**Proposed Amendment: N.J.A.C. 7:13-1.11**

Authorized By: Robert E. Hughey, Commissioner,  
Department of Environmental Protection.  
Authority: N.J.S.A. 13:1D-1 et seq. and 58:16A-50 et  
seq.  
DEP Docket No.: 050-82-09.

A public hearing concerning this rule will be held on November  
10, 1982 at 10:00 A.M. at:  
North Plainfield Municipal Building  
263 Somerset Street  
North Plainfield, NJ 07061

Interested persons may submit in writing, data, views or  
arguments relevant to the proposal on or before November 17,  
1982. These submissions, and any inquiries about submissions and  
responses, should be addressed to:  
Clark Gilman  
Bureau of Flood Plain Management  
Division of Water Resources  
CN 029  
1911 Princeton Avenue  
Trenton, NJ 08625

The Department of Environmental Protection thereafter may adopt  
this proposal without further notice (see: N.J.A.C. 1:30-3.5). The  
adoption becomes effective upon publication in the Register of a  
notice of adoption.  
This proposal is known as PRN 1982-413.

The agency proposal follows:

**Summary**

This proposed amendment provides for the application of rules  
and regulations concerning the development and use of land in  
designated floodways to portions of the streams located within  
North Plainfield and Somerville Boroughs, and the City of  
Plainfield. Regulations of delineated flood hazard areas are  
designed to preserve flood carrying capacity and to minimize the  
threat to the public safety, health and general welfare.

**Social Impact**

This proposed delineation applies added flood protection to the  
following areas within the Raritan River Basin: Boroughs of North  
Plainfield, Somerville and Watchung, within Somerset County and  
the City of Plainfield, within Union County.

**Economic Impact**

This proposed amendment will have only a minor economic  
impact. The proposed delineation would more clearly define the  
flood hazard area thus resulting in less requirements for flood  
insurance. Minor reductions of property value could result by  
restricting future development in the floodway and requiring  
elevated construction designs in flood fringe areas. However,  
minor property value diminution would be offset by the savings to  
governmental bodies and private homeowners due to little or no

future rehabilitation and rescue expenditures from flood damage in  
the delineated area.

Full text of the proposal follows (additions indicated in boldface  
thus).

7:13-1.11 Delineated floodways

(a)-(c) (No change.)

(d) A list of delineated streams in the Passaic-Hackensack Basin  
and a list of delineated streams in the Raritan Basin follow:

**The floodway and flood hazard area of the Green Brook from  
Jefferson Avenue to the upstream Plainfield City Boundary at  
Terrill Road within the Boroughs of North Plainfield and  
Watchung, Somerset County and the City of Plainfield, Union  
County; Stony Brook from its confluence with Green Brook  
upstream to the North Plainfield-Watchung municipal  
boundary, within North Plainfield Borough and the Raritan  
River from the downstream to upstream municipal boundary  
of Somerville Borough, within the Borough of Somerville,  
Somerset County; and by adding to it the floodway and flood  
hazard area of Cedar Brook from the downstream Plainfield  
City Boundary upstream to Steele Avenue, within the City of  
Plainfield, Union County; Peters Brook from its confluence  
with the Raritan River to the upstream Somerville Borough  
municipal boundary, Ross Brook from its confluence with  
Peters Brook upstream to Routes 202-206, all within the  
Borough of Somerville, Somerset County.**

(e)-(i) (No change.)

OFFICE OF ADMINISTRATIVE LAW NOTE: A map  
delineating the flood hazard area described in this notice was  
submitted as part of the Department's notice of proposed rule. This  
map can be inspected at:

Bureau of Flood Plain Management  
Division of Water Resources  
1911 Princeton Avenue  
CN 029  
Trenton, NJ 08625

or

Office of Administrative Law  
Administrative Filings  
88 East State Street  
CN 301  
Trenton, NJ 08625

(b)

**DIVISION OF WATER RESOURCES**

**Flood Hazard Area Delineations  
Flood Delineations Along the Stony Brook  
within the Township of East Amwell,  
Hunterdon County**

**Proposed Amendment: N.J.A.C. 7:13-1.11**

Authorized By: Robert E. Hughey, Commissioner,  
Department of Environmental Protection.  
Authority: N.J.S.A. 13:1D-1 et seq. and 58:16A-50 et  
seq.  
DEP Docket No.: 049-82-09.

A public hearing concerning this rule will be held on November  
15, 1982 at 10:00 A.M. at:

Division of Water Resources  
 Conference Room A  
 1474 Prospect Street  
 Trenton, NJ

Bureau of Flood Plain Management  
 Division of Water Resources  
 1911 Princeton Avenue  
 CN 029  
 Trenton, NJ 08625

**Interested persons** may submit in writing, data, views or arguments relevant to the proposal on or before November 17, 1982. These submissions, and any inquiries about submissions and responses, should be addressed to:

Clark Gilman  
 Bureau of Flood Plain Management  
 Division of Water Resources  
 CN 029  
 1911 Princeton Avenue  
 Trenton, NJ 08625

or

Office of Administrative Law  
 Administrative Filings  
 88 East State Street  
 CN 301  
 Trenton, NJ 08625

(a)

The Department of Environmental Protection thereafter may adopt this proposal without further notice (see: N.J.A.C. 1:30-3.5). The adoption becomes effective upon publication in the Register of a notice of adoption.

This proposal is known as PRN 1982-414.

The agency proposal follows:

**Summary**

This proposed amendment provides for the application of rules and regulations concerning the development and use of land in designated floodways to portions of the Stony Brook, as described above. Regulations of delineated flood hazard areas are designed to preserve flood carrying capacity and to minimize the threat to the public safety, health and general welfare.

**Social Impact**

This proposed delineation applies added flood protection to the following areas within the Raritan River Basin: the Townships of East Amwell and West Amwell, within Hunterdon County.

**Economic Impact**

This proposed amendment will have only a minor economic impact. The proposed delineation would more clearly define the flood hazard area thus resulting in less requirements for flood insurance. Minor reductions of property value could result by restricting future development in the floodway and requiring elevated construction designs in flood fringe areas. However, minor property value diminution would be offset by the savings to governmental bodies and private homeowners due to little or no future rehabilitation and rescue expenditures from flood damage in the delineated area.

**Full text** of the proposal follows (additions indicated in boldface thus).

7:13-1.11 Delineated floodways

(a)-(c) (No change.)

(d) A list of delineated streams in the Passaic-Hackensack Basin and a list of delineated streams in the Raritan Basin follow:

**The floodway and flood hazard area of approximately 1,650 feet of the Stony Brook (downstream) from 2,000 feet downstream of Linvale Road within the Township of East Amwell.**

(e)-(i) (No change.)

OFFICE OF ADMINISTRATIVE LAW NOTE: A map delineating the flood hazard area described in this notice was submitted as part of the Department's notice of proposed rule. This map can be inspected at:

**DIVISION OF WATER RESOURCES**

**Flood Hazard Area Delineations  
 Flood Delineations Along the Delaware River,  
 Shabakunk Creek, West Branch Shabakunk  
 Creek, Little Shabakunk Creek, Stony  
 Brook, Benden's Brook and Rock Brook**

**Proposed Amendment: N.J.A.C. 7:13-1.11**

Authorized By: Robert E. Hughey, Commissioner,  
 Department of Environmental Protection.  
 Authority: N.J.S.A. 13:1D-1 et seq. and 58:16A-50 et  
 seq.  
 DEP Docket No.: 048-82-09.

A **public hearing** concerning this rule will be held on November 16, 1982 at 10:00 A.M. at:

Division of Water Resources  
 Conference Room A  
 1474 Prospect Street  
 Trenton, NJ

**Interested persons** may submit in writing, data, views or arguments relevant to the proposal on or before November 17, 1982. These submissions, and any inquiries about submissions and responses, should be addressed to:

Clark Gilman  
 Bureau of Flood Plain Management  
 Division of Water Resources  
 CN 029  
 Trenton, NJ 08625

The Department of Environmental Protection thereafter may adopt this proposal without further notice (see: N.J.A.C. 1:30-3.5). The adoption becomes effective upon publication in the Register of a notice of adoption.

This proposal is known as PRN 1982-415.

The agency proposal follows:

**Summary**

This proposed amendment provides for the application of rules and regulations concerning the development and use of land in designated floodways to portions of the Delaware River and the Shabakunk Creek and some of its tributaries, as described above. Regulations of delineated flood hazard areas are designed to preserve flood carrying capacity and to minimize the threat to the public safety, health and general welfare.

**Social Impact**

This proposed delineation applies added flood protection to the

following areas within the Delaware and Raritan River Basin: Townships of Ewing, Lawrence, Hopewell and the Boroughs of Hopewell, Pennington and Hightstown, all within Mercer County, New Jersey.

**Economic Impact**

This proposed amendment will have only a minor economic impact. The proposed delineation would more clearly define the flood hazard area thus resulting in less requirements for flood insurance. Minor reductions of property value could result by restricting future development in the floodway and requiring elevated construction designs in flood fringe areas. However, minor property value diminution would be offset by the savings to governmental bodies and private homeowners due to little or no future rehabilitation and rescue expenditures from flood damage in the delineated area.

**Full text** of the proposal follows (additions indicated in boldface thus).

7:13-1.11 Delineated floodways

(a)-(b) (No change.)

(c) A list of the delineated streams in the Delaware Basin follows:

**The floodway and flood hazard area of the Delaware River from the downstream corporate limit in Ewing upstream to the Hopewell Township, Mercer County corporate limit; Shabakunk Creek from 1,800 feet downstream of Colonial Lake Dam upstream to Bull Run Road; West Branch Shabakunk Creek from its mouth at the junction with the Shabakunk Creek upstream to a point 2,000 feet upstream of Carlton Avenue; the Little Shabakunk Creek from approximately 500 feet above its confluence with Assunpink Creek upstream 16,950 feet to the Rider College Driveway culvert immediately upstream from the Reading Railroad tracks; Rocky Brook from U.S. Route 130 upstream 7,100 feet through a portion of Peddie Lake; the Stony Brook tributary to the Millstone River from Province Line Road upstream to State Route 518; and Beden's Brook from a point 360 feet downstream of Province Line Road upstream to a driveway culvert 300 feet downstream of the Route 518 culvert in Hopewell Borough and add to it the floodway and flood hazard area of Jacobs-Ewing Creek from its confluence with the Delaware River upstream to Scotch Road within the Townships of Ewing and Hopewell, Mercer County, New Jersey.**

(d)-(i) (No change.)

OFFICE OF ADMINISTRATIVE LAW NOTE: A map delineating the flood hazard area described in this notice was submitted as part of the Department's notice of proposed rule. This map can be inspected at:

Bureau of Flood Plain Management  
 Division of Water Resources  
 1911 Princeton Avenue  
 CN 029  
 Trenton, NJ 08625

or

Office of Administrative Law  
 Administrative Filings  
 88 East State Street  
 CN 301  
 Trenton, NJ 08625

(a)

**DIVISION OF WATER RESOURCES**

**Flood Hazard Area Delineations  
 Flood Delineations Along the Batsto River  
 and Skit Branch**

**Proposed Amendment: N.J.A.C. 7:13-1.11**

Authorized By: Robert E. Hughey, Commissioner,  
 Department of Environmental Protection.  
 Authority: N.J.S.A. 13:1D-1 et seq. and 58:16A-50 et  
 seq.  
 DEP Docket No.: 047-82-09.

A public hearing concerning this rule will be held on November 18, 1982 at 10:00 A.M. at:

Township of Washington  
 Municipal Building  
 River Road  
 Greenbank, NJ

Mailing Address:  
 Township of Washington  
 Municipal Building  
 R.D. 2/P.O. Box 235  
 Egg Harbor, NJ

Interested persons may submit in writing, data, views or arguments relevant to the proposal on or before November 18, 1982. These submissions, and any inquiries about submissions and responses, should be addressed to:

Clark Gilman  
 Bureau of Flood Plain Management  
 Division of Water Resources  
 CN 029  
 Trenton, NJ 08625

The Department of Environmental Protection thereafter may adopt this proposal without further notice (see: N.J.A.C. 1:30-3.5). The adoption becomes effective upon publication in the Register of a notice of adoption.

This proposal is known as PRN 1982-416.

The agency proposal follows:

**Summary**

This proposed amendment provides for the application of rules and regulations concerning the development and use of land in designated floodways to portions of the Batsto River and Skit Branch. Regulations of delineated flood hazard areas are designed to preserve food carrying capacity and to minimize the threat to the public safety, health and general welfare.

**Social Impact**

This proposed delineation applies added flood protection to the following areas within the Mullica River Basin: Townships of Shamong and Washington, Burlington County and the Wharton State Forest.

**Economic Impact**

This proposed amendment will have only a minor economic impact. The area subject to this proposed flood hazard area delineation is relatively undeveloped. Few existing structures will be affected by this amendment. The proposed delineation would more clearly define the flood hazard area thus resulting in less requirements for flood insurance. Minor reductions of property

value could result by restricting future development in the floodway and requiring elevated construction designs in flood fringe areas. However, minor property value diminution would be offset by the savings to governmental bodies and private homeowners due to little or no future rehabilitation and rescue expenditures from flood damage in the delineated area.

**Full text** of the proposal follows (additions indicated in boldface thus).

7:13-1.11 Delineated floodways

- (a)-(g) (No change.)
- (h) A list of delineated streams in the Mullica River Basin follow:

**The flood hazard area of the Batsto River from its confluence with the Mullica River upstream to Carranza Road and Skit Branch from its mouth at the confluence with the Batsto River upstream to Carranza Road within the Townships of Shamong and Washington, Burlington County and the Wharton State Forest.**

- (i) (No change.)

OFFICE OF ADMINISTRATIVE LAW NOTE: A map delineating the flood hazard area described in this notice was submitted as part of the Department's notice of proposed rule. This map can be inspected at:

Bureau of Flood Plain Management  
Division of Water Resources  
1911 Princeton Avenue  
CN 029  
Trenton, NJ 08625

or

Office of Administrative Law  
Administrative Filings  
88 East State Street  
CN 301  
Trenton, NJ 08625

**(a)**

**DIVISION OF WATER RESOURCES**

**Flood Hazard Area Delineations  
Flood Delineations Along Wreck Pond Brook,  
Hannabrand Brook Tributary, Shark River  
and its Tributaries of Jumping Brook and  
Branch "E", Hog Swamp Brook, Poplar  
Brook, Whale Pond Brook, Turtle Mill  
Brook and Little Silver Creek**

**Proposed Amendments: N.J.A.C. 7:13-1.11**

Authorized By: Robert E. Hughey, Commissioner,  
Department of Environmental Protection.  
Authority: N.J.S.A. 13:1D-1 et seq. and 58:16A-50 et  
seq.  
DEP Docket No.: 046-82-09.

A public hearing concerning this rule will be held on November 19, 1982 at 10:00 A.M. at:

Police Headquarters  
Bailey's Corner Road and Allaire Road  
Wall Township, NJ 07719

**Interested persons** may submit in writing, data, views or arguments relevant to the proposal on or before November 19, 1982. These submissions, and any inquiries about submissions and responses, should be addressed to:

Clark Gilman  
Bureau of Flood Plain Management  
Division of Water Resources  
CN 029  
Trenton, NJ 08625

The Department of Environmental Protection thereafter may adopt this proposal without further notice (see: N.J.A.C. 1:30-3.5). The adoption becomes effective upon publication in the Register of a notice of adoption.

This proposal is known as PRN 1982-417.

The agency proposal follows:

**Summary**

This proposed amendment provides for the application of rules and regulations concerning the development and use of land in designated floodways to portions of the Wreck Pond Brook and the Shark River and some of their tributaries. Regulations of delineated flood hazard areas are designed to preserve flood carrying capacity and to minimize the threat to the public safety, health and general welfare.

**Social Impact**

This proposed delineation applies added flood protection to the following areas within the Delaware River Basin: Townships of Wall, Neptune, Tinton Falls and Ocean, and the Boroughs of Deal, Long Branch, West Long Branch, Oceanport and Little Silver all within Monmouth County.

**Economic Impact**

This proposed amendment will have only a minor economic impact. The proposed delineation will more clearly define the flood hazard area thus resulting in less requirements for flood insurance. Minor reductions of property value could result by restricting future development in the floodway and requiring elevated construction designs in flood fringe areas. However, minor property value diminution would be offset by the savings to governmental bodies and private homeowners due to little or no future rehabilitation and rescue expenditures from flood damage in the delineated area.

**Full text** of the proposal follows (additions indicated in boldface thus).

7:13-1.11 Delineated floodways

- (a)-(b) (No change.)
- (c) A list of delineated streams in the Delaware Basin follows:

**The floodway and flood hazard area of the Wreck Pond Brook from Old Mill Pond Road to 4,320 feet upstream of Martins Road in Wall Township, Monmouth County; Hannabrand Brook from its confluence with Wreck Pond Brook upstream to the intersection of Route 34 and Allenwood Road in Wall Township, Monmouth County; Shark River from Route 18 upstream to Shafto Road in Wall, Neptune and Tinton Falls Townships, Monmouth County; Tributary E from its confluence with Shark River to 4,400 feet upstream of Wyckoff Road in Wall Township, Monmouth County; Jumping Brook from its confluence with Shark River upstream to Jumping Brook Road in Neptune Township, Monmouth County; Hog Swamp Brook from Monmouth Road to 1,400 feet upstream of Route 18 in Ocean Township, Monmouth County; Poplar**

**Brook from its confluence with the Atlantic Ocean to 300 feet downstream of Roller Road in the Borough of Deal and Ocean Townships, Monmouth County; Whale Pond Brook from its confluence with the Atlantic Ocean to the upstream Borough of Long Branch Boundary in the Borough of Long Branch, Monmouth County; Turtle Mill Brook from its confluence with the Branchport Creek upstream to Monmouth Road in the Boroughs of West Long Branch and Oceanport, Monmouth County; Little Silver Creek from Seven Bridges Road to the upstream Borough of Little Silver Boundary in the Borough of Little Silver, Monmouth County.**

(d)-(i) (No change.)

OFFICE OF ADMINISTRATIVE LAW NOTE: A map delineating the flood hazard area described in this notice was submitted as part of the Department's notice of proposed rule. This map can be inspected at:

Bureau of Flood Plain Management  
 Division of Water Resources  
 1911 Princeton Avenue  
 CN 029  
 Trenton, NJ 08625

or

Office of Administrative Law  
 Administrative Filings  
 88 East State Street  
 CN 301  
 Trenton, NJ 08625

**(a)**

**DIVISION OF WATER RESOURCES**

**Water Pollution Control  
 Construction of Wastewater Treatment  
 Facilities**

**Proposed New Rules: N.J.A.C. 7:14-2.13,  
 2.14 and 2.15**

Authorized By: Robert E. Hughey, Commissioner,  
 Department of Environmental Protection.  
 Authority: N.J.S.A. 58:10A-4, -5(d) and 58:25-8.  
 DEP Docket No.: 043-82-09

Interested persons may submit in writing, data, views or arguments relevant to the proposal on or before November 17, 1982. These submissions, and any inquiries about submissions and responses, should be addressed to:

Anthony Ricigliano, P. E., Assistant Director  
 Construction Grants Administration  
 Division of Water Resources  
 Department of Environmental Protection  
 CN 029  
 Trenton, NJ 08625  
 609-292-0950

The Department of Environmental Protection thereafter may adopt this proposal without further notice (see: N.J.A.C. 1:30-3.5). The adoption becomes effective upon publication in the Register of a notice of adoption.

This proposal is known as PRN 1982-410.

The agency proposal follows:

**Summary**

The Division of Water Resources has prepared these proposed rules with the advice and cooperation of local governments and

professional and trade associations. These rules, concerning trench excavation used as backfill, equipment charges and extra work, and substantial and final completion of pipe projects, further standardize certain procedures in the wastewater treatment facilities construction process. See the adopted new rules on this subject at 14 N.J.R. 1155(b), this issue.

**Social Impact**

These rules will affect local governments, sewerage and utilities authorities, engineering consultants, and construction contractors. These interests will have uniform procedures to follow to comply with regulatory or grant requirements.

**Economic Impact**

In general, these rules may decrease cost to governmental agencies, owners, grantees, consultants, and contractors due to standardization of procedures. Unnecessary and redundant work will in many cases be eliminated. No other economic impact is anticipated.

Full text of the proposed new rules follows.

7:14-2.13 Trench excavation used as backfill

(a) Unacceptable trench or excavation backfill materials are materials which may cause damage to piping systems and/or cannot be compacted/consolidated to yield the desired density as specified in the Bid Documents. The use of the excavated materials in the trench backfill will be governed by the following standards:

1. Clay, organics and silt shall be used as a trench backfill material if in conformance with the project specifications. The project specifications shall address the use of the above soil types for their use as a trench backfill material with special consideration given to the location, that is rights-of-way, easements, roadways, and unimproved areas. The owner/engineer shall require sufficient soils testing to determine the suitability of these trench backfill materials.

2. Hard materials (blacktop, concrete, stone, and rock) may be used in the backfill of a trench if provided for in the contract documents. These materials MAY ONLY BE PLACED IN THE MIDZONE of the trench in such a manner so as not to cause any potential hazard to the pipe or create voids that will cause adverse settlement. Special considerations should be given to the location, that is rights-of-way, easements, roadways and unimproved areas. The MIDZONE is defined as that portion of the trench beginning two feet above the top of the pipe, after compaction of the pipe envelope, to a point two feet below the final road or ground surface. The size of hard materials placed in the MIDZONE are limited to a maximum size of 12 inches in any direction.

3. Trees, stumps and frozen material shall never be used in the trench backfill.

(b) In the event that procedures specified in (a) above are not adhered to, the Department may require that all materials not conforming to the contract documents shall be eliminated from the backfill and spoiled to a spoil site approved by the Department in accordance with the New Jersey Solid Waste Management Act.

7:14-2.14 Construction equipment charges and Extra Work

(a) The contractor is entitled to all identifiable direct job equipment cost associated with Extra Work. The current issue of "Rental Rate for Construction Equipment" (Blue Book) shall be utilized to establish cost for construction equipment.

(b) Where the contractor utilizes contractor owned equipment, there shall be no additional overhead and profit factor applied to the rate charged for equipment costs. The overhead and profit allowance included in N.J.A.C. 7:14-2.7 do not apply to contractor owned equipment rates charged for Extra Work as identified above.

(c) Where the contractor utilizes equipment not owned by the contractor, overhead and profit rates established in N.J.A.C. 7:14-2.7 shall be applied to the equipment rental costs.

7:14-2.15 Substantial and Final Completion of pipe projects; guarantee

(a) Substantial Completion is that date certified by the engineer when the construction of the project or a functional part thereof is sufficiently completed, in accordance with the Contract Documents, so that the project or a part can be utilized for the purpose for which it was intended.

1. When all or a part of the work is substantially complete, the contractor shall, in writing to the owner and the engineer, certify that such work is substantially complete and request that the engineer issue a Certificate of Substantial Completion. Within a reasonable time thereafter, the owner, contractor and engineer shall make an inspection of the work to determine the status of completion. If the engineer considers the work substantially complete, the engineer will prepare and deliver to the owner a Certificate of Substantial Completion which shall fix the date of Substantial Completion.

2. If the engineer does not consider the work substantially complete, he shall notify the contractor in writing, giving his reason therefore and listing the items to be completed or corrected.

3. The contractor shall warrant and guarantee, for a period of one year from the date of Substantial Completion or such other period as specified in the contract documents, that the completed work is free from defects due to faulty materials, equipment, or workmanship, and the contractor shall promptly make corrections as may be necessary by reason of such defects, including the repair of any damage to other parts of the work resulting from such defects. The engineer shall give notice of observed defects with reasonable promptness. In the event that the contractor fails to make such repairs, adjustments, or other work that may be necessary by such defects, within a reasonable time, the owner may do so and charge the contractor the cost thereby incurred, including all direct and indirect costs. The Performance Bond and Payment Bond will remain in full force and effect through the guarantee period.

(b) Final Completion is that date at which the work has been completed, all defective work has been corrected, and clean-up has been accomplished. Unless a Certificate of Substantial Completion has been issued, the guarantee period shall begin upon certification by the engineer of Final Completion.

(a)

## DIVISION OF WATER RESOURCES

### Water Quality Management Underground Injection Control Program

#### Proposed Amendments: N.J.A.C. 7:14A-1.9, 5.11, 5.13, 5.15 and 5.16

Authorized By: Robert E. Hughey, Commissioner,  
Department of Environmental Protection.  
Authority: N.J.S.A. 58:10A-4, 58:4A-4.1, 58:12A-4.  
DEP Docket No.: 052-82-09.

Interested persons may submit in writing, data, views or arguments relevant to the proposal on or before November 17, 1982. These submissions, and any inquiries about submissions and responses, should be addressed to:

Philip Yeany  
Office of Regulatory Affairs  
Department of Environmental Protection  
CN 402  
Trenton, NJ 08625

Any inquiries about this proposal may also be made by calling Mr. Yeany at (609) 292-2689.

The Department of Environmental Protection thereafter may adopt this proposal without further notice (see: N.J.A.C. 1:30-3.5). The adoption becomes effective upon publication in the Register of a notice of adoption.

This proposal is known as PRN 1982-411.

The agency proposal follows:

#### Summary

The Department has submitted to the U.S. Environmental Protection Agency (EPA) a proposal for the assumption by the State of primacy for the Underground Injection Control (UIC) Program. The purpose of the UIC Program is to control the subsurface emplacement of fluids by well injections that may endanger underground sources of drinking water. The proposed amendments would alter the New Jersey Pollutant Discharge Elimination System (NJPDES) Regulations, N.J.A.C. 7:14A, in order to meet EPA's UIC Program requirements for State assumption. (See 40 CFR Part 123.)

The proposed amendment to the definition of "permit" and "permit by rule" is needed to clearly identify the Department's utilization of the permit by rule as applied to the UIC Program. The permit by rule is used to permit Class V injection wells.

The proposed amendments to the definition of "packer" and to N.J.A.C. 7:14A-5.11, 5.13, 5.15, and 5.16 are necessary inasmuch as the NJPDES Regulations for the UIC Program are required by Federal law to be equivalent to or more stringent than the Federal program standards. (See the Federal Safe Drinking Water Act, 42 U.S.C. 300f et seq.) The proposed redefinition of the term "packer" will subject more types of these devices to Department review. (See 40 CFR 146.03.) As proposed, N.J.A.C. 7:14A-5.11 would be changed so that in analyzing the need for corrective action for Class III injection wells, NJDEP must consider the overall effect of a project rather than the discrete effect of each well. (See 40 CFR 122.44.) The proposed amendment to N.J.A.C. 7:14A-5.13 broadens the criteria which the Department will use in determining what corrective or preventive action must be taken by a permit applicant. Under the new criteria the Department would have to consider not only the toxicity of native fluids, injected fluid and by-products at injection but also the mutagenicity and pathogenicity of the fluids and by-products. (See 40 CFR 146.07.) The proposed change to N.J.A.C. 7:14A-5.15 will modify the minimum operating requirements for Class II injection wells by deleting an exemption from the requirements. (See 40 CFR 146.32.) The modification to N.J.A.C. 7:14A-5.16 broadens the criteria for determining the number, location, construction and frequency of monitoring of monitoring wells to be used for Class III wells. Under the new criteria the Department would have to consider not only the toxicity of injected fluid, the formation water, and the process by-products, but also the mutagenicity and pathogenicity of the fluid, water, and by-products. (See 40 CFR 146.32.)

#### Social Impact

The proposed amendments will apply greater safeguards to underground sources of drinking water by conforming State regulations concerning the UIC Program to the requirements of Federal law and regulations.

#### Economic Impact

Minimal economic impact will result from the proposed amendment inasmuch as it is intended to conform the State regulatory requirements with that of the Federal program.

#### Environmental Impact

The proposed amendments will have a small but significant beneficial environmental impact. By proposing and adopting these rules, the State will qualify for the assumption of primacy for the UIC Program. This will enable NJDEP to control discharges which might endanger underground sources of drinking water.

**Full text** of the proposal follows (additions indicated in boldface **thus**; deletions indicated in brackets [thus]).

7:14A-1.9 Definitions

As used in this chapter, the following words and terms shall have the following meanings.

“Packer” means a device lowered into a well [which can be expanded] to produce a [water tight] **fluid-tight** seal.

“Permit” means an authorization, license, or equivalent control document issued by the Department to implement the requirements of this chapter even where any or all of the conditions of the permit have been stayed. Permit does not include [UIC authorization by rule or] any permit which requires EPA review pursuant to 40 CFR Part 123.75, such as a “draft permit” or a “proposed permit”.

“Permit by rule” means a provision of this chapter stating that a “facility or activity” is deemed to have a RCRA or NJPDES permit if it meets the requirements of the [provisions] **applicable regulations**.

7:14A-5.11 Corrective or preventive action

(a) (No change.)

(b) Requirements:

1.-3. (No change.)

**4. Class III wells only: When setting corrective action requirements, the Department shall consider the overall effect of the project on the hydraulic gradient in potentially affected USDWs and the corresponding changes in potentiometric surface(s) and flow direction(s) rather than the discrete effect of each well. If a decision is made that corrective action is not necessary based on the determination above, the monitoring program required in N.J.A.C. 7:14A-5.16(c)2 shall be designed to verify the validity of such determinations.**

7:14A-5.13 General criteria and standards

(a) (No change.)

(b) Corrective or preventive action: In determining the adequacy of corrective action proposed by the applicant under N.J.A.C. 7:14A-[5.12] **5.11** and in determining the additional steps needed to prevent fluid movement into underground sources of drinking water, the following criteria and factors shall be considered by the Department:

1. [Toxicity] **Nature** and volume of the injected fluids;
  2. [Toxicity] **Nature** of native fluids or by-products of injection;
  - 3.-9. (No change.)
- (c)-(d) (No change.)

7:14A-5.15 Criteria and standards applicable to Class II wells

(a)-(b) (No change.)

(c) Operating, monitoring, and reporting requirements:

1. Operating requirements: Operating requirements shall, at a minimum, specify that:

i. [Except during well stimulation for enhanced recovery wells, injection] **Injection** pressure at the well head shall not exceed a maximum which shall be calculated so as to assure that the pressure in the injection zone during injection does not initiate new fractures or propagate existing fractures in the injection zone. In no case shall injection pressure initiate fractures in the confining zone or cause the movement of injection or formation fluids into an underground source of drinking water.

ii. (No change.)

2.-3. (No change.)

7:14A-5.16 Criteria and standards applicable to Class III wells

(a) (No change.)

(b) Construction requirements:

1.-8. (No change.)

9. In determining the number, location, construction and frequency of monitoring of the monitoring wells the following criteria shall be considered:

i.-iv. (No change.)

v. The [toxicity] **nature** and volume of the injected fluid, the formation water, and the process by-products; and

vi. (No change.)

(c) (No change.)

(a)

**DIVISION OF WATER RESOURCES**

**DIVISION OF WASTE MANAGEMENT**

**Pollutant Discharge Elimination System  
Hazardous Waste Management**

**Proposed Amendments: N.J.A.C. 7:14A-4.2  
and 4.3**

Authorized By: Robert E. Hughey, Commissioner,  
Department of Environmental Protection.  
Authority: N.J.S.A. 58:10A-1 et seq. and 13:1E-1 et seq.  
DEP Docket No.: 044-82-09.

**Interested persons** may submit in writing, data, views or arguments relevant to the proposal on or before November 17, 1982. These submissions, and any inquiries about submissions and responses, should be addressed to:

Ellen Radow, Chief  
Water Quality Management Element  
Division of Water Resources  
CN 029  
Trenton, NJ 08625

The Department of Environmental Protection thereafter may adopt this proposal without further notice (see: N.J.A.C. 1:30-3.5). The adoption becomes effective upon publication in the Register of a notice of adoption.

This proposal is known as PRN 1982-412.

The agency proposal follows:

**Summary**

This proposal amends N.J.A.C. 7:14A-4 of the NJPDES Regulations to allow a facility which is regulated pursuant to Section 402 of the Federal Water Pollution Control Act to be classified as an industrial waste management facility, where hazardous waste generated from intracompany/intrastate sources is used as a chemical agent or for biological seeding.

The Department adopted the major portion of the “Hazardous Waste Regulations” on October 8, 1981 (see 13 N.J.R. 706(b)). These regulations require any person who treats, stores, or disposes of hazardous waste to obtain a hazardous waste facility permit or an industrial waste facility permit. The industrial waste management facility permit was designed to require substantive compliance by facilities which treat or dispose of hazardous waste and are presently regulated by the Division of Water Resources pursuant to the New Jersey Pollutant Discharge Elimination System Regulations, N.J.A.C. 7:14A (that is, land application of hazardous waste, disposal of hazardous waste in surface impoundments, underground injection of hazardous waste, and treatment of hazardous waste in a wastewater treatment facility provided this waste is generated intrastate and intracompany). One of the proposed amendments (N.J.A.C. 7:14A-4.2(a)) clarifies the

regulations to provide that if any of the facilities that treat or dispose of hazardous waste, and are regulated by NJPDES, also receive any hazardous waste from intercompany or interstate sources, that facility is a hazardous waste facility and is subject to primary regulation by the Division of Waste Management pursuant to N.J.A.C. 7:26.

The second amendment (N.J.A.C. 7:14A-4.3) reinforces the Department's commitment to encourage recycling of hazardous materials. Specifically, the Department finds that where a hazardous waste, which is generated intrastate, could be used as a substitution for a chemical agent in a wastewater treatment process, such an agent may be utilized provided there is an approved modification of the discharge (NJPDES) permit. The NJPDES permit will be the monitoring device to assure that there is quality control when hazardous waste is used as a substitute for the chemical agent. In addition, any generator of hazardous waste is required to complete a manifest to accompany the shipment. The facility which receives the hazardous waste must then keep records of the waste accepted and utilized in the wastewater treatment unit.

#### Social Impact

The regulation of the treatment, storage and disposal of hazardous waste addresses an ever increasing public concern that such activities should be performed not only in an environmentally sound manner but with foremost concern for public health and safety. These proposed amendments recognize these concerns and therein clarify that when any hazardous waste is accepted from intercompany and interstate sources, often on a commercial basis, the Department imposes its most stringent requirements. This type of treatment, storage and disposal of hazardous waste requires a person to comply with the Hazardous Waste Regulations, N.J.A.C. 7:26, and with the Federal regulations promulgated under the Resource Conservation and Recovery Act of 1976. It is especially important for the Department to clarify this point, since the Environmental Protection Agency has recently adopted additional regulations for land treatment of hazardous waste, (40 CFR Parts 264 and 265, dated July 13, 1982). The Department finds that the State "Hazardous Waste Regulations" (N.J.A.C. 7:26), "NJPDES Regulations" (N.J.A.C. 7:14A), and newly adopted Federal regulations represent a comprehensive program to regulate land disposal of hazardous waste.

In terms of the use of hazardous waste in a treatment unit, the Department proposes an amendment to promote the reuse of hazardous waste. This is important so that the total amount of hazardous waste that needs to be disposed of may be reduced. This proposal allows a company to use hazardous waste in the wastewater treatment unit only where there has been an amendment to the discharge permit, which will not become final until there has been an opportunity for public comment. The discharge permit process will provide the Department an opportunity to thoroughly review any application for use of a hazardous waste as a substitution for a chemical agent in a wastewater treatment unit. Any necessary modification of the permit, including monitoring of the effluent, can be made in the course of this process. Thus, the Department is able to fulfill two important objectives: regulation of the treatment of hazardous waste and the promotion of the reuse of hazardous waste.

#### Economic Impact

Many companies in New Jersey have manufacturing processes which result in a strong acid waste which must be neutralized prior to discharge into waters of the State. However, the most common product used to neutralize strong acid may require control of increased amounts of suspended solids. An alternate method to neutralize strong acid is the use of caustic which is soluble in water, and thus does not present a problem by increasing the amount of suspended solids. However, the use of raw caustic is cost prohibitive since it is five times more expensive than lime. Another reason that caustic is not used is that it is a by-product of chlorine

production which has been significantly reduced due to the economy and the environmental problems associated with its production and disposal. To the extent that similar chemical agents may be substituted or used for biological seeding in treatment units, there may be similar economic savings and in some cases such reuse of waste may result in payment to those facilities which reuse such waste.

**Full text** of the proposal follows (additions indicated in boldface **thus**; deletions indicated in brackets [thus]).

#### 7:14A-4.2 Scope

(a) Specific inclusions: An industrial waste management facility (IWMF) **treats, stores, or disposes of hazardous waste which is received exclusively from intracompany and intrastate sources and includes the following:**

1. Wastewater treatment units which are subject to regulation under Section 402 or 307(a) of the Federal Act and that:

i.-ii (No change.)

iii. [The hazardous wastewater is exclusively received from intracompany and intrastate sources.] **Meet the definition of "tank".**

2. The treatment [or], storage **or disposal** of hazardous waste in a surface impoundment; and

3.-4. (No change.)

**5. Notwithstanding the provisions of (a)1 above, an IWMF may receive hazardous waste from intrastate/intracompany sources provided that:**

i. **A modification of the NJPDES/DSW or SIU permit is obtained pursuant to N.J.A.C. 7:14A-2.12; and**

ii. **The hazardous waste is used for the sole purpose of substitution for a chemical agent which is normally used in the IWMF wastewater treatment unit; or**

iii. **The hazardous waste is received and used for the purpose of biologically seeding a wastewater treatment unit.**

(b)-(c) (No change.)

#### 7:14A-4.3 Definitions

The following definitions apply to this subchapter.

**"Chemical agent" means those elements, compounds, or mixtures that disperse, dissolve, emulsify, neutralize, precipitate, reduce, solubilize, oxidize, concentrate, congeal, entrap, fix, gel, make the pollutant mass more rigid or viscous, or otherwise facilitate the mitigation of deleterious effects or removal of the pollutant from the wastewater.**

(a)

## DIVISION OF WASTE MANAGEMENT

### Hazardous Waste Management

**Proposed Amendments: N.J.A.C. 7:26-1.1, 1.4, 1.7, 2.14, 3.8, 5.5, 7.6, 8.16, 9.1, 9.5, 9.9**

Authorized By: Robert E. Hughey, Commissioner,  
Department of Environmental Protection.  
Authority: N.J.S.A. 13:1E-1 et seq.  
DEP Docket No.: 045-82-09.

**Interested persons** may submit in writing, data, views or arguments relevant to the proposal on or before November 17, 1982. These submissions, and any inquiries about submissions and responses, should be addressed to:

J. Mark McQuerrey, Esq.  
 Department of Environmental Protection  
 Office of Regulatory Services  
 CN 402  
 Trenton, NJ 08625

The Department of Environmental Protection thereafter may adopt this proposal without further notice (see: N.J.A.C. 1:30-3.5). The adoption becomes effective upon publication in the Register of a notice of adoption.

This proposal is known as PRN 1982-418.

The agency proposal follows:

**Summary**

This proposal is the result of mandates by the United States Environmental Protection Agency (USEPA) that this Department make these changes to be authorized to implement a hazardous waste management program under the Federal Resource Conservation and Recovery Act of 1976, 42 USC 6901. In order to obtain Federal authorization to run the program and in order to receive associated Federal funding, New Jersey's hazardous waste rules must be at least as stringent as the comparable Federal rules. This proposal has been specifically required because the rules being amended are considered by the USEPA to allow less regulatory control than the Federal rules. To summarize, the proposal is described as follows:

N.J.A.C. 7:26-1.1 sets forth the scope of regulation for non-hazardous wastes and includes exemption from regulation for certain non-hazardous waste activities. These exemptions include onsite storage for less than six months and waste container-pickup facilities, among others. The Federal hazardous waste rules exempt onsite storage for only 90 days and do not exempt container-pickup facilities. The amendment to this regulation makes it clear that the non-hazardous waste exemptions are not applicable to hazardous waste activities.

N.J.A.C. 7:26-1.4. Definitions

The definition of "container" now includes "trucks, railroad tank cars or barges for bulk transportation by water". The Federal definition in 40 CFR 260.10 does not include such vehicles and reference to them is proposed to be deleted.

The definition of "disposal" is proposed to be changed to include language identical to that in 40 CFR 260.10, the definitional section of the Federal rules. The USEPA felt that the existing definition in New Jersey's rules was less comprehensive than its counterpart.

The definition of "generator" is proposed to be changed to be identical to that in 40 CFR 260.10. This change makes clear that a person who causes waste to become a hazardous waste, is a generator, regardless of whether that person actually produced the waste originally.

The definition of "hazardous waste", as now written, implies that a waste must be designated by the Department to be considered hazardous. N.J.A.C. 7:26-8 includes lists of wastes which are hazardous without the need for any Departmental action. The amendment required by the USEPA clarifies this fact.

The definition of "hazardous waste landfill" failed to exclude underground injection from falling within the definition. Since the definition defines a landfill as a place where waste is "placed in or on the land", injection wells would technically fit the landfill description. Such a result is not intended by the rules.

The definition of "leachate" is proposed to be amended to include only liquid which has been in contact with waste, but to no longer also require that that liquid contain material from the waste. Thus, only contact with waste will be needed for a liquid to be considered leachate.

The definition of "open burning" is proposed to be changed to be identical to that in 40 CFR 260.10. The Federal rules define "open burning" as combustion without emission controls, where the

prior New Jersey version described open burning to be any fire which burns directly to the air, without a stack or chimney. The Federal definition includes a broader activity within the meaning of open burning and, since most types of open burning are prohibited, the need to have New Jersey's definition consistent becomes evident.

The definition of "personnel" should apply to all of the solid waste rules. Reference to "section 8" was an error and is proposed to be deleted.

N.J.A.C. 7:26-1.7 allows this Department to vary from the specific requirements of any rule if an applicant or permittee can show that their alternative is as good as what is required. This rule is amended to no longer allow the Department to permit a variation from the hazardous waste rules. The Federal rules do not have a comparable variance rule.

N.J.A.C. 7:26-2.14(a); 3.8(a) and 5.5(e) are all new rules which make clear that the non-hazardous waste rules in N.J.A.C. 7:26-2, 3, and 5.5 do not apply to hazardous waste activities. Since "solid waste" is defined to include hazardous waste, the numerous references to "solid waste" in the N.J.A.C. non-hazardous waste rules might now result in an interpretation that the non-hazardous waste rules somehow apply to hazardous waste activities.

N.J.A.C. 7:26-7.6(c) is proposed to be amended to require that a transporter of hazardous waste from a foreign country into New Jersey must give this Department four weeks advance notice of the shipment. The comparable Federal rule now requires the same prior notice.

N.J.A.C. 7:26-8.16 uses the term "toxic" to describe the list of chemical constituents set forth in that section. The proposed change replaces this with the term "hazardous", thus making this phrase consistent with all other references in the rules.

N.J.A.C. 7:26-9.1(c) is proposed to be amended solely for clarification purposes. The substance of the rule is not affected.

N.J.A.C. 7:26-9.5(a) is the rule which sets the requirement of groundwater monitoring at hazardous waste facilities. Without the proposed amendment, the rule appears to tie the requirement for groundwater monitoring to the New Jersey Pollutant Discharge Elimination System Permits, issued under the regulations in N.J.A.C. 7:14A. It was not our intent to tie hazardous wastewater monitoring to the NJPDES program but, rather, to require that hazardous waste facilities have monitoring when the hazardous waste rules became effective. In addition to removing this confusion, the proposed amendment cross-references a section of the Federal rules (40 CFR 265.90) which sets a procedure for certain hazardous waste facility operators to prove that they don't need to monitor the groundwater to the degree required, due to the lack of any groundwater pollution threat at the facility.

N.J.A.C. 7:26-9.9(n) requires that hazardous waste disposal facilities file a deed notice that the property in question was used for hazardous waste management. The USEPA rule change requires that a notice in the deed must remain, even if all hazardous waste is removed from the property. Without the proposed amendment, the current N.J.A.C. rule allows the deed notice to be removed after removal of all hazardous waste.

**Social Impact**

The proposed amendments, though minor in nature, would have social impact, if they were not already effective under Federal law. Since the changes are for the sole purpose of making New Jersey's rules equivalent to existing Federal rules, the only additional impact derives from the elimination of areas of possible ambiguity.

**Economic Impact**

No economic impact will result from the proposed amendments inasmuch as the purpose of the rules is to make New Jersey's hazardous waste rules equivalent to the Federal rules on this subject, which are already in effect.

**Full text** of the proposal follows (additions indicated in boldface thus; deletions indicated in brackets [thus]).

Amendments proposed to obtain interim authorization of the State hazardous waste program are as follows:

7:26-1.1 Scope of rules

(a)-(b) (No change.)

**(c) The regulations in this subchapter are not applicable to activities associated with hazardous waste. See N.J.A.C. 7:26-7, 8, 9, 10, 11 and 12 to find the hazardous waste rules.**

7:26-1.4 Definitions

“Container” means any portable device in which a material is stored, transported, treated, disposed of, or otherwise handled [but shall not include trucks, railroad tank cars or barges for bulk transportation by water].

“Disposal” means the storage, treatment, utilization, processing or final disposition of solid waste [.] , **specifically including the discharge, deposit, injection, dumping, spilling, leaking, or placing of any solid waste or hazardous waste into or on any land or water so that such solid waste or hazardous waste or any constituent thereof may enter the environment or be emitted into the air or discharged into any waters, including groundwaters.**

“Generator” means any person, by site, whose act or process produces solid waste as defined at N.J.A.C. 7:26-1.6 [.] , **or whose act first causes solid waste to become subject to regulation.**

“Hazardous Waste” means any solid waste or combination of solid wastes, including toxic, corrosive, irritating, sensitizing, radioactive, biologically infectious, explosive or flammable solid waste, which poses a present or potential threat to human health, living organisms or the environment, provided that the solid waste [has been designated hazardous] **is hazardous** in accordance with the standards and procedures set forth at N.J.A.C. 7:26-8.

“Hazardous waste landfill” means a solid waste facility or part of a facility where hazardous waste is placed in or on land and which is not a land treatment facility [or], a surface impoundment **or an injection well.**

“Leachate” means liquid that has been in contact with solid waste [and contains dissolved or suspended materials from that solid waste].

“Open burning” means [any fire whose products of combustion are emitted directly into the open air, and are not directed thereto through the stack or chimney of an incinerator.] **the combustion of any material without the following characteristics:**

1. **Control of combustion air to maintain adequate temperature for efficient combustion;**
2. **Containment of the combustion reaction in an enclosed device to provide sufficient residence time and mixing for complete combustion;**
3. **Control of emission of the gaseous combustion products;**

“Personnel” or “facility personnel” means all persons who work at, or oversee the operations of, a hazardous waste facility, and whose actions or failure to act may result in noncompliance with the requirements of [section 8 of] this chapter.

7:26-1.7 Variance

Upon written presentation of acceptable evidence that deviation from [these rules and regulations] **the provisions of this chapter** will satisfy the intent and purpose of [these regulations] **this chapter**, a variance may be granted by the commissioner in accordance with the rules of practice and procedure for the Bureau of Solid Waste Management, adopted pursuant to the

Administrative Procedure Act (N.J.S.A. 52:14B-1 et seq.)[.] , **except that this section shall not permit variation from regulations associated with hazardous waste. See N.J.A.C. 7:26-7, 8, 9, 10, 11 and 12 to find the hazardous waste rules.**

7:26-2.14 Applicability

**The regulations in this subchapter are not applicable to activities associated with hazardous waste. See N.J.A.C. 7:26-7, 8, 9, 10, 11 and 12 to find the hazardous waste rules.**

7:26-3.8 Applicability

**The regulations in this subchapter are not applicable to activities associated with hazardous waste. See N.J.A.C. 7:26-7, 8, 9, 10, 11 and 12 to find the hazardous waste rules.**

7:26-5.5 Penalties and rebates

(a)-(d) (No change.)

**(e) The regulations in the subchapter are not applicable to Code violations associated with hazardous waste activities. See N.J.A.C. 7:26-7, 8, 9, 10, 11 and 12 to find the hazardous waste rules.**

7:26-7.6 Hazardous waste facility operator responsibilities

(a)-(b) (No change.)

(c) When importing hazardous waste from a foreign country, a person must meet all requirements of this subchapter for the manifest except that:

1.-2. (No change.)

**3. Notice in writing shall be given to the Department at least four weeks in advance of the date that the waste is expected to arrive at the facility. Notice of subsequent shipments of the same waste from the same foreign source is not required.**

7:26-8.16 Hazardous constituents

The hazardous constituents criteria for listing hazardous wastes (see N.J.A.C. 7:26:8.[4]6) are listed below. Test methods approved by the Department shall be used in determining whether the waste in question contains a given [toxic] **hazardous** constituent.

7:26-9.1 Scope and applicability

(a)-(b) (No change.)

(c) The standards and requirements of this subchapter do not apply to:

1.-3. (No change.)

**4. Any generator accumulating waste onsite for less than 90 days [in compliance with] except to the extent that the requirements are included in N.J.A.C. 7:26-9.3.**

5.-9. (No change.)

7:26-9.5 Groundwater monitoring system

(a) [The] **By the effective date of this rule amendment, the owner or operator shall [design, construct and implement] have designed, constructed and implemented a groundwater monitoring system [when required] in accordance with N.J.A.C. 7:14A-6 (Rules of the Division of Water Resources) [.] unless the owner or operator can demonstrate to the Department that all or part of the groundwater monitoring requirements may be waived, pursuant to 40 CFR 265.90. No waiver may be granted by any rules other than as set forth in 40 CFR 265.90.**

7:26-9.9 General Post-closure care requirements

(a) Except as N.J.A.C. 7:26-9.1 provides otherwise, this section applies to all hazardous waste facilities where hazardous wastes [are intended to] remain at the facility site after closure is completed.

(b)-(m) (No change.)

(n) Requirements for notice in deed to property include the following:

1. (No change.)

2. If at any time the owner or operator or any subsequent owner of land upon which a hazardous waste facility is located removes the waste and waste residues, the liner, if any, and all contaminated underlying and surrounding soil, [the owner or operator may remove the notation on the deed to the facility property or other instrument normally examined during title search, or] the owner or operator may add a notation to the deed or instrument indicating the removal of the waste.

## HIGHER EDUCATION

### (a)

#### BOARD OF HIGHER EDUCATION

##### State Colleges

##### Auxiliary Organization Regulations

##### Proposed New Rules: N.J.A.C. 9:2-13.1 through 13.12

Authorized By: Board of Higher Education, T. Edward Hollander, Chancellor and Secretary.

Authority: N.J.S.A. 18A:64-26-18A:64-44 (P.L. 1982 c. 16).

**Interested persons** may submit in writing, data, views or arguments relevant to the proposal on or before November 17, 1982. These submissions, and any inquiries about submissions and responses, should be addressed to:

Eric M. Perkins, Esq.  
Administrative Practice Officer  
Department of Higher Education  
225 West State Street  
CN 542  
Trenton, NJ 08625

The Board of Higher Education thereafter may adopt this proposal without further notice (see: N.J.A.C. 1:30-3.5). The adoption becomes effective upon publication in the Register of a notice of adoption.

This proposal is known as PRN 1982-419.

The agency proposal follows:

##### Summary

The proposed new regulations implement the "Public College Organization Act" (P.L. 1982 c. 16) which was signed into law in April. The new Act requires the Board of Higher Education to implement regulations to provide for the proper operation of auxiliary organizations and to regulate their fiscal integrity. An auxiliary organization, for purposes of the Act, performs selected functions or operations of a college while maintaining an identity distinct from that of the college. The proposed regulations address these concerns, providing accounting standards, insurance and bonding requirements, capital and operational reserve standards, and reporting requirements.

##### Social Impact

The proposed regulations attempt to provide proper oversight for auxiliary organizations which are beneficial to students and colleges. Auxiliary organizations will operate college bookstores, dormitories and food service operations for the mutual benefit of the student and the college.

##### Economic Impact

The operation of auxiliary organizations will provide additional revenues to the colleges which elect to organize them. They will

also provide better quality services to college students at a lower cost than provided by an outside vendor.

Full text of the proposed new rule follows.

#### SUBCHAPTER 13. AUXILIARY CORPORATION REGULATIONS

##### 9:2-13.1 Incorporation

An auxiliary organization formed pursuant to N.J.S.A. 18A:64-26 et seq. shall be incorporated as a non-profit corporation pursuant to the laws of the State of New Jersey. A copy of the certificate of incorporation and the annual report of the corporation shall be filed with the Department of Higher Education. Prior to initial operation an auxiliary organization shall have its name approved by the Board of Higher Education.

##### 9:2-13.2 Approval to operate

Prior to organization and operation, the College Board of Trustees shall submit to the Board of Higher Education a list of functions to be performed by the organization. Additional functions may be submitted for approval at any time but must be approved prior to implementation. The Board will consider and approve such functions as it determines to be within the intent of the law. Such approval shall be for an indefinite duration. Approval may be revoked by the Board of Higher Education upon notice and opportunity to be heard for violation of the enabling statute or these regulations, or for other good cause. Hearings shall be conducted as contested cases pursuant to N.J.S.A. 52:14B-10 and N.J.A.C. 1:1-1. Such hearings shall be conducted either by the Board of Higher Education or by an Administrative Law Judge.

##### 9:2-13.3 Accounting and auditing

An auxiliary organization shall operate and maintain its accounts in accordance with the generally accepted accounting principles and practices of the American Institute of Certified Public Accountants, except where otherwise specifically required by these regulations.

##### 9:2-13.4 Employee bonding

The treasurer and all employees of the organization who are involved in handling monies shall be bonded in the amount of \$100,000.

##### 9:2-13.5 Insurance

Each auxiliary organization shall obtain insurance policies, including workers' compensation and liability insurance, in amounts sufficient to protect the interest of the organization.

##### 9:2-13.6 Appropriation of earnings

Any monies in excess of those required for operational or capital reserves pursuant to these regulations may be declared surplus by the Board of Directors of the organization by formal resolution. Such surplus monies may be expended by the auxiliary organization for any purpose which will further the educational mission of the college as determined by the College Board of Trustees. Monthly reports of the expenditure of surplus monies shall be made to the College Board of Trustees. Annual reports of such expenditure shall be made to the Department of Higher Education.

##### 9:2-13.7 Reserve accounts

Each auxiliary organization shall create and maintain a capital reserve and replacement account equivalent to two percent of the original acquisition cost of the organization's property and equipment. Each auxiliary organization shall also create and maintain a current operating reserve equivalent to one month's payroll.

9:2-13.8 Use of college facilities

The College Board of Trustees shall annually report to the Board of Higher Education the use of college facilities and services, and the fair rental value rendered to the college for the use of such facilities and services, by auxiliary organizations.

9:2-13.9 Organization personnel

Employees of auxiliary organizations are within the unclassified service of the State Civil Service system. The Department of Civil Service shall establish job titles and salary schedules for such employees, provided, however, that no individual who was an employee of a college auxiliary organization prior to the date of the enabling legislation shall be reduced in salary as a result of such classification.

9:2-13.10 Employment of college personnel

An auxiliary organization may employ individuals who are employed by a college, provided that such employment does not conflict with the employee's college employment. No employee of a college may be compensated by an auxiliary organization for services rendered in any capacity during the hours while the employee is in the employ of the college. Each organization shall annually provide the college with a list of college employees who have been employed by the organization in the preceding 12 months.

9:2-13.11 Purchasing

An auxiliary organization shall make such purchases as are necessary for its operation. Such purchases shall be made through competitive bidding whenever possible. The standards contained within N.J.S.A. 52:34-6 shall serve as general guidelines for competitive bidding.

9:2-13.12 Organization/college contracts

Agreements between the college and the auxiliary organization for the purchases of services shall be ratified by formal resolution of the College Board of Trustees and the Board of Directors of the organization. No such agreement shall be for more than a one year period but may be renewable.

Administrative Practice Officer  
Division of Medical Assistance  
and Health Services  
324 East State Street  
CN 712  
Trenton, NJ 08625

The Department of Human Services thereafter may adopt this proposal without further notice (see: N.J.A.C. 1:30-3.5). The adoption becomes effective upon publication in the Register of a notice of adoption.

This proposal is known as PRN 1982-402.

The agency proposal follows:

**Summary**

This proposal updates the list of non-legend (over-the-counter) drugs (Appendix B), hypodermic syringes and/or needles (Appendix C), and legend (prescription) devices (Appendix D) which are reimbursable under either the New Jersey Medicaid Program and/or Pharmaceutical Assistance for the Aged and Disabled (PAAD) Program. The extent of the changes are significant enough to warrant republication of the entire list.

This proposal will impact primarily the Medicaid (Title XIX) program. It will very minimally impact the PAAD program because the only non-legend drugs and drug products which may be billed to the PAAD program are insulin and insulin syringes and/or insulin needles pursuant to N.J.A.C. 10:51-5.20.

All non-legend products and legend devices are coded according to the National Drug Code (NDC) and must be dispensed and charged only in accordance with the sizes listed.

Pharmaceutical providers will receive an individual copy of this material from Blue Cross. Pharmaceutical providers are responsible for utilizing these lists when billing either the Medicaid and/or PAAD program in accordance with established guidelines. New Jersey Blue Cross, acting on behalf of the Division of Medical Assistance and Health Services, is responsible for processing and paying correctly submitted claims.

**Social Impact**

There should be a positive social impact on Medicaid recipients and PAAD beneficiaries who will continue to receive up-to-date pharmaceuticals. There should be virtually no social impact on pharmaceutical providers, who have been utilizing the listings in Appendices B, C and D, with periodic updating, for several years.

**Economic Impact**

Since there is no change in the reimbursement policy or procedures, this proposal will have no economic impact on the Division of Medical Assistance and Health Services, which administers both the Medicaid and PAAD programs.

Pharmaceutical providers will be reimbursed for dispensing the drugs and drug products listed in Appendices B, C and D.

Medicaid recipients are not required to pay toward the cost of these drugs. PAAD beneficiaries are obligated by law (N.J.S.A. 30:4D-22) to pay a \$2.00 co-payment.

The text, of the lists of (Appendix B) General Non-Legend Drugs, (Appendix C) Hypodermic Syringes and Needles Assigned Product Codes for All Brands and (Appendix D) Legend Devices, is to be deleted and replaced in its entirety.

Copies of the full text consisting of N.J.A.C. 10:51-1, Appendices B, C and D, may be obtained from or made available for review by contacting:

**HUMAN SERVICES**

(a)

**DIVISION OF MEDICAL ASSISTANCE AND HEALTH SERVICES**

**Pharmaceutical Services Manual  
List of Non-Legend Drugs, Hypodermic Syringes, and/or Needles, and Legend Devices**

**Proposed Amendment: N.J.A.C. 10:51-1, Appendices B, C and D**

Authorized By: George J. Albanese, Commissioner,  
Department of Human Services.

Authority: N.J.S.A. 30:4D-6b(6), -7, -7b and -22.

Interested persons may submit in writing, data, views or arguments relevant to the proposal on or before November 17, 1982. These submissions, and any inquiries about submissions and responses, should be addressed to:

Division of Medical Assistance and Health Services
324 East State Street
CN 712
Trenton, NJ 08625

or

Office of Administrative Law
Administrative Filings
88 East State Street
CN 301
Trenton, NJ 08625

(a)

DIVISION OF MEDICAL ASSISTANCE AND HEALTH SERVICES

Hospital, Special Hospital, and Physicians' Manual
Second Opinion for Certain Elective Surgical Procedures

Proposed Amendments: N.J.A.C. 10:52-1.3, 10:53-1.3, 10:54-1.2 and 10:54-3

Authorized By: George J. Albanese, Commissioner, Department of Human Services.
Authority: N.J.S.A. 30:4D-6a(l) (5) and 30:4D-7 and 7b.

Interested persons may submit in writing, data, views or arguments relevant to the proposal on or before November 17, 1982. These submissions, and any inquiries about submissions and responses, should be addressed to:

Administrative Practice Officer
Division of Medical Assistance and Health Services
CN 712
Trenton, NJ 08625

The Department of Human Services thereafter may adopt this proposal without further notice (see: N.J.A.C. 1:30-3.5). The adoption becomes effective upon publication in the Register of a notice of adoption.

This proposal is known as PRN 1982-403.

The agency proposal follows:

Summary

The Department of Human Services recently adopted a rule requiring a second opinion for certain elective surgical procedures. (The notice of adoption appeared March 15, 1982 at 14 N.J.R. 278(c). The rule became effective April 1, 1982.) This proposal will modify the rule by removing the second opinion requirement from certain surgical procedures.

These modifications apply to Medicaid patients who are children or young adults. A second opinion will no longer be required for any herniorrhaphy (hernia repair) performed on patients 18 years of age or under, with one very important exception pertaining to an umbilical herniorrhaphy. This procedure will require a second opinion when performed on a patient under five years of age.

Three procedure codes (0643, 0644, and 0645) are being deleted from the second opinion requirement. These procedure codes pertain to spinal fusion, and are most frequently related to treatment of scoliosis in children and young adults.

This proposal also clarifies the requirement that patients eligible for both Medicare and Medicaid are exempt from the second opinion requirement.

Those procedures which will not require a second opinion for the specified age groupings are designated by double plus (††). The rest of the procedure codes remain the same as adopted in the March 15, 1982 Register at 14 N.J.R. 278(c). This symbol will help both the contractor and the provider identify which procedures require a second opinion, and which do not. However, providers are not required to use this symbol when completing the claim form. Providers should continue to submit Medicaid claims to the appropriate contractor in the normal manner.

Social Impact

There is no increase or decrease in services associated with this proposal. There might be a positive social impact on young Medicaid patients, who will not have to be examined by another physician prior to undergoing surgery.

Economic Impact

The Division of Medical Assistance and Health Services will continue to make reimbursement for the surgical procedures listed below as long as the provider complies with the second opinion requirement when it is applicable. Therefore, there should be no cost increase to the Medicaid program as long as utilization remains constant. There might be a small savings since the Division will not have to pay for the second opinion for those patients, and procedures, which are exempt from this requirement.

This proposal will primarily affect physicians and hospitals. However, there should be no significant economic impact on these two provider groups, because the Medicaid program has not changed the amount of reimbursement.

Full text of the proposal follows (additions indicated in boldface thus; deletions indicated in brackets [thus]).

10:52-1.3 Noncovered inpatient hospital services

(a) Benefits are not payable for any services rendered or items dispensed or furnished in connection with:

- 1.-15. (No change.)
16. Elective surgical procedures listed [under] unless a second opinion has been rendered by a board certified specialist[:].
i. Surgical procedures requiring a second opinion are identified by a plus symbol (†) in the procedure code manual (N.J.A.C. 10:54-3). A code with a double plus symbol (††) preceding the code indicates that a second opinion is not required for a child 18 years of age or under.
[i.] (1) (No change.)
[ii.] (2) (No change.)
[iii.] (3) (No change.)
[iv.] (4) (No change.)
[v.] (5) (No change.)
[vi.] (6) Spinal Fusion

- 0634
0635
0636
0637
0638
0639
0640
0641
0642
[0643]
[0644]
[0645]

ii. Medicare/Medicaid eligible recipients are excluded from the mandatory second opinion requirement.

10:53-1.3 Noncovered inpatient special hospital services

(a) Benefits are not payable for any services rendered or items dispensed or furnished in connection with:

- 1.-14. (No change.)
15. Elective surgical procedures listed unless a second opinion has been rendered by a board certified specialist[:].

i. Surgical procedures requiring a second opinion are identified by a plus symbol (†) in the procedure code manual (N.J.A.C. 10:54-3). A code with a double plus symbol (††) preceding the code indicates that a second opinion is not required for a child 18 years of age or under.

- [i.] (1) (No change.)
[ii.] (2) (No change.)
[iii.] (3) (No change.)
[iv.] (4) (No change.)
[v.] (5) (No change.)
[vi.] (6) Spinal Fusion

0634
0635
0636
0637
0638
0639
0640
0641
0642
[0643]
[0644]
[0645]

ii. Medicare/Medicaid eligible recipients are excluded from the mandatory second opinion requirement.

- (b) (No change.)

10:54-1.2 Scope of service

(a) Payment will be made for the medically necessary services, subject to the following limitations:

- 1.-2. (No change.)
3. Physician services provided in the hospital setting; inpatient:
i. (No change.)

ii. Neither the physician nor the hospital will be paid for the following elective surgical procedures unless a second opinion has been rendered by a board certified specialist[:].

(1) Surgical procedures requiring a second opinion are identified by a plus symbol (†) in the procedure code manual (N.J.A.C. 10:54-3). A code with a double plus symbol (††) preceding the code indicates that a second opinion is not required for a child 18 years of age or under.

- [(1)] (A) (No change.)
[(2)] (B) (No change.)
[(3)] (C) (No change.)
[(4)] (D) (No change.)
[(5)] (E) (No change.)
[(6)] (F) Spinal Fusion

0634
0635
0636
0637
0638
0639
0640
0641
0642
[0643]
[0644]
[0645]

(2) Medicare/Medicaid eligible recipients are excluded from the mandatory second opinion requirement.

- 4.-8. (No change.)
(b) (No change.)

CHAPTER 54
MANUAL FOR PHYSICIANS SERVICES

SUBCHAPTER 3. PROCEDURE CODE MANUAL

A plus symbol (†) preceding the following procedures codes indicate a second opinion is required by a board certified specialist before reimbursement is made for elective surgery [:]. A code with

a double plus symbol (††) preceding the code indicates that a second opinion is not required for a child 18 years of age or under.

[†03515] †3515 †3516 ††3631 ††3632 ††3633 ††3634 ††3635 ††3646 ††3651 ††3661 ††3662 ††3663 ††3664 ††3666 [†0643] [†0644] [†0645].

(a)

DIVISION OF PUBLIC WELFARE

General Assistance Manual
Local Assistance Board Appointments

Proposed Amendment: N.J.A.C. 10:85-2.2

Authorized By: George J. Albanese, Commissioner,
Department of Human Services.
Authority: N.J.S.A. 44:8-111(d), 44:8-115 and 44:8-116.

Interested persons may submit in writing, data, views or arguments relevant to the proposal on or before November 17, 1982. These submissions, and any inquiries about submissions and responses, should be addressed to:

G. Thomas Riti, Director
Division of Public Welfare
CN 716
Trenton, NJ 08625

The Department of Human Services thereafter may adopt this proposal without further notice (see: N.J.A.C. 1:30-3.5). The adoption becomes effective upon publication in the Register of a notice of adoption.

This proposal is known as PRN 1982-420.

The agency proposal follows:

Summary

This proposal amends a section of the General Assistance Manual which inappropriately grants the Division of Public Welfare/Bureau of Local Operations (DPW/BLO) authority to approve or disapprove the continuation in office of a local assistance board (LAB) member when a replacement has not been appointed within 30 days. The proposal is predicated on an opinion of the Attorney General, stating that such power is not conveyed by the statute.

Social Impact

This procedural change places the responsibility upon local municipal governments to resolve holdover and appointment difficulties, as described above, without intervention by the Division of Public Welfare.

Economic Impact

There is no perceived economic impact, inasmuch as no cash flow is involved.

Full text of the proposal follows (deletions indicated in brackets [thus]).

10:85-2.2 Establishment of local assistance board

- (a) (No change.)
(b) (No change.)
1. (No change.)
2. Terms of office rules are:
i.-iii. (No change.)
iv. When circumstances such as illness or a governmental irregularity preclude timely appointment of a new member, the

incumbent shall continue until such new appointee can take office. [If this period extends beyond 30 days, approval for the continuation shall be obtained from the DPW/BLO.]  
v. (No change.)  
(c)-(i) (No change.)

## LABOR

### (a)

#### DIVISION OF WORKPLACE STANDARDS

##### Wage and Hour Definition of "Administrative"

##### Proposed Amendment: N.J.A.C. 12:56-7.2.

Authorized By: Roger A. Bodman, Commissioner,  
Department of Labor.  
Authority: N.J.S.A. 34:11-56a19.

A public hearing concerning this rule will be held on November 4, 1982 at 10:00 A.M. at:  
Labor and Industry Building  
Room 1301  
John Fitch Plaza  
Trenton, NJ

Interested persons may submit in writing, data, views or arguments relevant to the proposal on or before November 17, 1982. These submissions, and any inquiries about submissions and responses, should be addressed to:  
William J. Clark, Assistant Commissioner  
Division of Workplace Standards  
New Jersey Department of Labor  
CN 054  
Trenton, NJ 08625

The Department of Labor thereafter may adopt this proposal without further notice (see: N.J.A.C. 1:30-3.5). The adoption becomes effective upon publication in the Register of a notice of adoption.

This proposal is known as PRN 1982-426.

The agency proposal follows:

##### Summary

The proposed amendment clarifies the definition of "administrative" by correcting an editorial error made in (a)3 and (a)4.

##### Social Impact

The amendments do not enlarge upon obligations imposed upon an employer or employee.

##### Economic Impact

No additional expense is imposed upon the employer.

Full text of the proposal follows (additions indicated in boldface thus; deletions indicated in brackets [thus]).

12:56-7.2 Definition of administrative

- (a) "Administrative" means any employee:
  - 1.-2. (No change.)
  - 3. [Who regularly and directly assists a proprietor, or an employee employed in a bonafide executive or administrative capacity; or
  - 4. Who performs under only general supervision work along specialized or technical lines requiring special training, experience, or knowledge; or

5. Who executes under only general supervision special assignments and tasks; and ] Who regularly and directly assists a proprietor, or an employee employed in a bonafide executive or administrative capacity; or who performs under only general supervision work along specialized or technical lines requiring special training, experience, or knowledge; or who executes under only general supervision special assignments and tasks; and

[6.] 4. Who devotes less than 20 percent of his work to nonexempt work or less than 40 percent if employed by a retail or service establishment[, provided that in either case he retains his role as manager and supervises two or more full-time employees]; and  
[7.] 5. (No change.)  
(b) (No change.)

## LAW AND PUBLIC SAFETY

### (b)

#### DIVISION OF MOTOR VEHICLES

##### Driver Improvement Schools Amount of Fee

##### Proposed Amendment: N.J.A.C. 13:20-17.3

Authorized By: Clifford W. Snedeker, Director, Division of Motor Vehicles.  
Authority: N.J.S.A. 39:5-30.4 and P.L. 1982 c.53.

Interested persons may submit in writing, data, views or arguments relevant to the proposal on or before November 17, 1982. These submissions, and any inquiries about submissions and responses, should be addressed to:  
Clifford W. Snedeker, Director  
Division of Motor Vehicles  
25 South Montgomery Street  
Trenton, NJ 08666

The Division of Motor Vehicles thereafter may adopt this proposal without further notice (see: N.J.A.C. 1:30-3.5). The adoption becomes effective upon publication in the Register of a notice of adoption.

This proposal is known as PRN 1982-423.

The agency proposal follows:

##### Summary

This proposal implements P.L. 1982, c.53 which amended N.J.S.A. 39:5-30.4. The statutory amendment raised the fee for attending driver improvement school from a maximum of \$30.00 to a maximum of \$40.00. The proposed amendment to N.J.A.C. 13:20-17.3 implements this statutory change by increasing the fee charged from \$20.00 to \$40.00.

##### Social Impact

This proposal will have an impact on persons required to attend driver improvement school because of unsatisfactory driving records. These persons will now be charged an increased fee.

##### Economic Impact

There is a beneficial economic impact on the State in that the increased fee for attending driver improvement school will offset in part the costs incurred in running the driver improvement school.

**Full text** of the proposal follows (additions indicated in boldface **thus**; deletions indicated in brackets [thus]).

13:20-17.3 Amount of fee

Any person attending a Division of Motor Vehicles driver improvement school shall pay an attendance fee of [ \$20.00 ] **\$40.00**.

(a)

## DIVISION OF MOTOR VEHICLES

### Licensing Service Restoration Fee for Suspended or Revoked License

#### Proposed New Rule: N.J.A.C. 13:21-9.3

Authorized By: Clifford W. Snedeker, Director, Division of Motor Vehicles.

Authority: N.J.S.A. 39:3-10a and P.L. 1982 c.53.

**Interested persons** may submit in writing, data, views or arguments relevant to the proposal on or before November 17, 1982. These submissions, and any inquiries about submissions and responses, should be addressed to:

Clifford W. Snedeker, Director  
Division of Motor Vehicles  
Department of Law and Public Safety  
25 South Montgomery Street  
Trenton, NJ 08666

The Division of Motor Vehicles thereafter may adopt this proposal without further notice (see: N.J.A.C. 1:30-3.5). The adoption becomes effective upon publication in the Register of a notice of adoption.

This proposal is known as PRN 1982-422.

The agency proposal follows:

#### Summary

The proposed new rule implements P.L. 1982, c.53, by establishing a license restoration fee authorized therein at \$30.00.

#### Social Impact

A \$30.00 license restoration fee shall be payable to the Division of Motor Vehicles by persons whose licenses have been suspended because of the licensees' violation of the Motor Vehicle and Traffic Laws or regulations adopted by the Division.

#### Economic Impact

There is a beneficial economic impact on the State in that part of the costs incurred in processing license suspensions and restorations will be recouped through collection of the restoration fee.

**Full text** of the proposed new rule follows.

13:21-9.3 License restoration fee

A fee of \$30.00 shall be payable to the Director of the Division of Motor Vehicles for the restoration of any license which has been suspended or revoked by reason of the licensee's violation of any of the provisions of Title 39 or any regulation adopted pursuant thereto.

(b)

## NEW JERSEY RACING COMMISSION

### Thoroughbred Rules

#### Proposed Amendments: N.J.A.C. 13:70-3.47, 6.55 and 18.6

#### Proposed New Rule: N.J.A.C. 13:70-6.56

Authorized By: New Jersey Racing Commission, John J. Reilly, Executive Director.

Authority: N.J.S.A. 5:5-22 and 5:5-30.

**Interested persons** may submit in writing, data, views or arguments relevant to the proposal on or before November 17, 1982. These submissions, and any inquiries about submissions and responses, should be addressed to:

John J. Reilly, Executive Director  
New Jersey Racing Commission  
404 Abington Drive  
East Windsor, NJ 08520

The New Jersey Racing Commission thereafter may adopt this proposal without further notice (see: N.J.A.C. 1:30-3.5). The adoption becomes effective upon publication in the Register of a notice of adoption.

This proposal is known as PRN 1982-424.

The agency proposal follows:

#### Summary

N.J.A.C. 13:70-3.47 would require all horses competing at New Jersey racetracks to be vaccinated for equine encephalitis as well as swamp fever, contagious equine diseases which pose a serious health hazard.

N.J.A.C. 13:70-6.55 would decrease the mandatory non-racing period for first time respiratory bleeders from 25 days to 14 days to reflect the consensus of veterinary opinion as to the period of down time needed to protect the horse.

N.J.A.C. 13:70-6.56 is a new rule that would require thoroughbred race horses which have not competed in a race for 30 days to demonstrate a published workout prior to starting in a race.

N.J.A.C. 13:70-18.6 would decrease the shortest race which three year old and older horses are eligible to compete in from 3/4 of a mile to 5/8 of a mile and would delete language from the rule now inconsistent with N.J.S.A. 5:5-49.

#### Social Impact

The proposed amendment to N.J.A.C. 13:70-3.47 would greatly aid the Commission in ensuring that competing race horses in New Jersey be free from infectious disease. The proposed amendment to N.J.A.C. 13:70-6.55 changes the "down time" required of an equine respiratory bleeder and will permit horses to race seven days sooner reflecting current veterinary practices and procedures. N.J.A.C. 13:70-6.56 is a new rule which would provide greater information for the betting public to aid in evaluating the prospects of thoroughbred racehorses which have not recently competed in pari-mutuel races. The proposed amendment to N.J.A.C. 13:70-18.6 would provide greater racing opportunity for thoroughbred racehorses by decreasing the minimum permissible distance for older horses from 3/4 mile to 5/8 mile.

#### Economic Impact

The amendment to N.J.A.C. 13:70-3.47 would increase the costs incurred by an owner of racehorses to the extent of the additional vaccination required. The amendment to N.J.A.C. 13:70-6.55 should have a positive economic impact from the perspective of

State revenue as well as that of the individual horse owner since respiratory bleeders will be permitted to enter races earlier thus resulting in longer fields in individual races and more racing opportunities. It is not anticipated that N.J.A.C. 13:70-6.56 would have any measurable economic impact on any segment of the racing industry or State revenue or costs. A minimal cost increase to the owner and/or trainer of such an animal might be anticipated in connection with attendant expenses to the actual workout. The amendment to N.J.A.C. 13:70-18.6 should have a positive economic impact on horse owners, trainers, as well as State revenues by increasing the number of racing opportunities for thoroughbreds.

**Full text** of the proposal follows (additions indicated in boldface thus; deletions indicated in brackets [thus]).

13:70-3.47 Track entrance; Coggins test requirement for horses, ponies or equine mascot

[No horse, pony or equine mascot may enter upon a track licensed by this Commission after April 1 of any year without evidence of a negative Coggins test. The original of such negative Coggins test must be attached to the foal certificate and/or eligibility certificate and filed with the racing secretary or the appropriate designated official. No certificate will be accepted without the copy of the negative Coggins test. In the case of a pony or equine mascot, evidence of a negative Coggins test, together with a picture of the animal involved must be filed with the horse identifier.]

(a) No horse shall be stabled on the grounds of any racing association nor shall any horse be eligible to enter any race absent presentation of a certificate of a negative Coggins test to the racing secretary. Said certificate shall:

1. Identify the horse by tattoo number;
2. Indicate said test was performed within one year prior to the date of presentation to the racing secretary;
3. Indicate said test was conducted by a laboratory approved by the United States Department of Agriculture; and
4. Be attached to the appropriate foal certificate.

(b) No horse shall be stabled on the grounds of any racing association nor shall any horse be eligible to enter any race absent presentation to the racing secretary of evidence of vaccination for equine encephalitis within the preceding year.

(c) In the case of any pony or other equine mascot, evidence of a negative Coggins test, as well as evidence of vaccination for equine encephalitis, together with a photograph of the animal, must be filed with the racing secretary.

13:70-6.55 Respiratory bleeders

A horse placed on the veterinarian's list for respiratory bleeding must remain on the list for [25] **14 calendar days and a second time respiratory bleeder must remain on the list for three months. A bleeder in the above categories is automatically released from the veterinarian's list after these dates; however, a horse which evidences respiratory bleeding a third time is barred from further racing in New Jersey.**

13:70-6.56 Starters; published workouts

A horse which has not started for **30 days or more shall be ineligible to race unless it has a published timed workout at a racetrack within 30 days prior to entry. Workouts following the entry of a horse shall appear on the official daily program.**

13:70-18.6 Conditions; program

(a) In making his program, the Racing Secretary shall respect these essential conditions;

- 1.-2. (No change.)
3. At a track with a chute at the six furlong pole, there shall be no race for three-year-olds and upward at less than [six] **five furlongs. [and a track not so equipped no race of three-year-olds and upward shall be at a less distance than 5-1/2 furlongs. This rule shall not apply to races over turf courses;]**

4. Not more than three overnight events of less distance than a mile shall be given on any day for horses three years old and upward unless conditions make it impossible to obtain sufficient entries to races of a mile or greater distance. [Section 29, Chapter 17, P.L. 1940, as amended and supplemented (racing law), required that:

i. "Every permit holder shall run at least one race every six days which shall be limited to horses foaled in New Jersey. If in the opinion of the Commission sufficient competition cannot be had among such class of horses, said race may be eliminated for said day and a substitute race provided instead."]

**(a)**

**NEW JERSEY RACING COMMISSION**

**Harness Racing  
Horse Vaccination and Respiratory Bleeding**

**Proposed Amendments: N.J.A.C. 13:71-6.24  
and 11.9**

Authorized By: New Jersey Racing Commission, John J. Reilly, Executive Director.  
Authority: N.J.S.A. 5:5-22 and 5:5-30.

**Interested persons** may submit in writing, data, views or arguments relevant to the proposal on or before November 17, 1982. These submissions, and any inquiries about submissions and responses, should be addressed to:

John J. Reilly, Executive Director  
New Jersey Racing Commission  
404 Abbington Drive  
East Windsor, NJ 08520

The New Jersey Racing Commission thereafter may adopt this proposal without further notice (see: N.J.A.C. 1:30-3.5). The adoption becomes effective upon publication in the Register of a notice of adoption.

This proposal is known as PRN 1982-425.

The agency proposal follows:

**Summary**

N.J.A.C. 13:71-6.24 would require all horses competing at New Jersey racetracks to be vaccinated for equine encephalitis as well as swamp fever, contagious equine diseases which pose a serious health hazard.

N.J.A.C. 13:71-11.9 would decrease the mandatory non-racing period for first time respiratory bleeders from 25 days to 14 days to reflect the consensus of veterinary opinion as to the period of down time needed to protect the horse.

**Social Impact**

The proposed amendment to N.J.A.C. 13:71-6.24 would greatly aid the New Jersey Racing Commission in ensuring that competing race horses in New Jersey be free from infectious disease. The proposed amendment to N.J.A.C. 13:71-11.9 changes the "down time" required of an equine respiratory bleeder and will permit horses to race seven days sooner reflecting current veterinary practices and procedures.

**Economic Impact**

The amendment to N.J.A.C. 13:71-6.24 would increase the costs incurred by an owner of race horses to the extent of the additional vaccination required. The amendment to N.J.A.C. 13:71-11.9 should have a positive economic impact from the perspective of State revenue as well as that of the individual horse owner since

respiratory bleeders will be permitted to enter races earlier thus resulting in larger fields in individual races and more racing opportunities.

**Full text** of the proposal follows (additions indicated in boldface **thus**; deletions indicated in brackets [thus]).

13:71-6.24 Evidence of a negative Coggins test; entrance upon a track

[No horse, pony or equine mascot may enter upon a track licensed by this commission after April 1 of any year, without evidence of a negative Coggins test. The original of such negative Coggins test must be attached to the foal certificate and/or eligibility certificate and filed with the racing secretary or the appropriate designated official. No certificate will be accepted without the copy of the negative Coggins test. In the case of a pony or equine mascot, evidence of a negative Coggins test, together with a picture of the animal involved, must be filed with the horse identifier.]

(a) **No horse shall be stabled on the grounds of any racing association nor shall any horse be eligible to enter any race absent presentation of a certificate of a negative Coggins test to the racing secretary. Said certificate shall:**

1. Identify the horse by tattoo number;
2. Indicate said test was performed within one year prior to the date of presentation to the racing secretary;
3. Indicate said test was conducted by a laboratory approved by the United States Department of Agriculture; and
4. Be attached to the appropriate eligibility certificate.

(b) **No horse shall be stabled on the grounds of any racing association nor shall any horse be eligible to enter any race absent presentation to the racing secretary of evidence of vaccination for equine encephalitis within the preceding year.**

(c) **In the case of any pony or other equine mascot, evidence of a negative Coggins test, as well as evidence of vaccination for equine encephalitis, together with a photograph of the animal, must be filed with the racing secretary.**

13:71-11.9 Respiratory bleeding; veterinarian's list

A horse placed on the veterinarian's list for respiratory bleeding must remain on the list for [25] 14 calendar days and a second time respiratory bleeder must remain on the list for three months. A bleeder in the above categories is automatically released from the veterinarian's list after these dates; however, a horse which evidences respiratory bleeding a third time is barred from further racing in New Jersey.

## **PUBLIC UTILITIES**

**(a)**

### **BOARD OF PUBLIC UTILITIES**

#### **Ethical Conduct and Ex Parte Communications**

#### **Proposed Amendment: N.J.A.C. 14:1-3.3**

Authorized By: Board of Public Utilities, Barbara A. Curran, President.

Authority: N.J.S.A. 48:2-12 and 48:2-13.

**Interested persons** may submit in writing, data, views or arguments relevant to the proposal on or before November 17, 1982. These submissions, and any inquiries about submissions and responses, should be addressed to:

Eugene J. Byrne, Esq.  
Regulatory Officer  
Board of Public Utilities  
1100 Raymond Boulevard  
Newark, NJ 07102

The Board of Public Utilities thereafter may adopt this proposal without further notice (see: N.J.A.C. 1:30-3.5). The adoption becomes effective upon publication in the Register of a notice of adoption.

This proposal is known as PRN 1982-421.

The agency proposal follows:

#### **Summary**

The proposed amendment would preclude parties to a contested formal proceeding before the Board from communicating or discussing the merits of the proceeding with the Board or presiding officer unless notice is given to all other parties to the proceeding to enable them to be present at the conference. The amendment further provides that copies of letters to the Board or staff concerning such a pending matter shall be mailed to all other parties.

#### **Social Impact**

The adoption of this amendment will assist in assuring the public and parties appearing before the Board that decisions of the Board are rendered based upon the record in a contested matter and not upon influences outside the record.

#### **Economic Impact**

There will be no economic impact associated with this proposal.

**Full text** of the proposal follows (additions indicated in boldface **thus**; deletions indicated in brackets [thus]).

14:1-3.3 Ethical conduct [required] and ex parte communications

(a)-(b) (No change.)

(c) **After the filing of a complaint or petition in a contested formal proceeding and prior to the issuance of a final order thereon, no parties to the proceeding, or their counsel, shall discuss the merits of such matter or proceeding with the Commissioners, or with the presiding officer involved unless reasonable notice is given to all parties who have appeared therein, to enable such parties to be present at the conference. When, after the filing of a complaint or petition and prior to the issuance of a final order thereon, letters are directed to the Board, or any member of its staff, regarding a formal proceeding, copies of such letters shall be mailed to all parties of record and proof of such service furnished upon request.**

(d) **In matters pending before the Office of Administrative Law, the provisions of N.J.A.C. 1:1-3.8 shall apply to the extent applicable.**

## **STATE**

**(b)**

### **DIVISION OF ELECTIONS**

#### **Voter Registration Timely Filing**

#### **Proposed Amendment: N.J.A.C. 15:10-1.4**

Authorized By: Jane Burgio, Secretary of State.

Authority: N.J.S.A. 19:31-6.9.

**Interested persons** may submit in writing, data, views or arguments relevant to the proposal on or before November 17, 1982. These submissions, and any inquiries about submissions and responses, should be addressed to:

Christine St. John  
 Director, Division of Elections  
 CN 300  
 Trenton, NJ 08625

The Secretary of State thereafter may adopt this proposal without further notice (see: N.J.A.C. 1:30-3.5). The adoption becomes effective upon publication in the Register of a notice of adoption.

This proposal is known as PRN 1982-401.

The agency proposal follows:

**Summary**

The present method of delineating the deadline for voter registration, using the mail registration form, is unfair to voters and creates administrative difficulties in the handling and recording of registration forms.

Under the present regulations, the essence of the deadline for accepting voter registration forms through the mail becomes the date of the postmark the form bears rather than the date it is received by the appropriate official or the date that the registration was accomplished. This gives rise to a dual deadline which favor persons registering through the mail over persons registering in person for whom no grace period exists.

Also, the inconsistent handling of the forms by the post office introduces an element of randomness into the postmarking process. Often, similarly dispatched forms will be imprinted with postmarks bearing different dates. In fact, it has been the experience of this office that a significant number of forms bear illegible postmarks or no postmark at all. This, again, contributes to unfair application of the existing deadline.

Recording the new registrations in the permanent registration record books is hindered by complications which arise from the present deadline regulations. Verification of registrations prior to entry in the permanent record become impractical given the large number of forms which must be entered after the deadline, but have not yet been received. Adequate inter-county verification of registration records is compromised by time consumed by processing forms during this grace period.

**Social Impact**

The proposed change regarding the delineation of the deadline for the acceptance of voter registration forms through the mail will have the effect of providing the public with a more precisely defined, and therefore, more equitable, deadline with which to comply. It is anticipated that the actual number of persons registering will be unaffected, while an increase in the percentage of registered voters voting will result. This increase will arise from a reduction in the number of disgruntled voters created through misunderstandings, and clerical errors, precipitated by the ambivalent deadline regulations presently in effect.

**Economic Impact**

The proposed change is purely procedural in nature. There will be no economic impact on the voters, the County Boards of Election, or the State of New Jersey.

**Full text** of the proposal follows (additions indicated in boldface **thus**; deletions indicated in brackets [thus]).

15:10-1.4 Acceptance of registrants after the 29th day

(a) [Any form not postmarked, but dated by the registrant on or before the 29th day of election shall be deemed timely, provided that it is received by mail not later than four days after the close of registration.] **No voter registration form shall be deemed timely filed unless received by the commissioner of registration**

or the Secretary of State on or before the 29th day prior to any election.

(b) (No change.)

TREASURY-GENERAL

(a)

DIVISION OF PENSIONS

**Alternate Benefit Program  
 Salary Deductions and Salary Reduction  
 Agreements**

**Proposed Amendment: N.J.A.C. 17:1-2.3**

Authorized By: William J. Joseph, Director, Division of Pensions.

Authority: N.J.S.A. 18A:66-192.

**Interested persons** may submit in writing, data, views or arguments relevant to the proposal on or before November 17, 1982. These submissions, and any inquiries about submissions and responses, should be addressed to:

William J. Joseph, Director  
 Division of Pensions  
 20 West Front Street  
 CN 295  
 Trenton, NJ 08625

The Division of Pensions thereafter may adopt this proposal without further notice (see: N.J.A.C. 1:30-3.5). The adoption becomes effective upon publication in the Register of a notice of adoption.

This proposal is known as PRN 1982-407.

The agency proposal follows:

**Summary**

The proposed amendments attempt to clarify the current rule concerning salary deductions and salary reduction agreements in the Alternate Benefit Program by rearranging the text therein and adding minor wording to clarify the existing language of the rule.

**Social Impact**

Present and future members of the Alternate Benefit Program involved in salary deductions and salary reduction agreements may be affected by this proposal.

**Economic Impact**

There is no economic impact to members of the Alternate Benefit Program since this proposal neither increases nor decreases any benefits or costs to such members. The proposal is merely intended to clarify existing language in the rule.

**Full text** of the proposal follows (additions indicated in boldface **thus**; deletions indicated in brackets [thus]).

17:1-2.3 Salary reduction agreements; **salary deductions**; limitations

[(a) The entry into a salary reduction agreement between an employee and his employing institution shall not be available to any participant during the period of time in which no employer contributions are made on his behalf to any retirement annuity contracts.

(b) Salary deductions for TIAA/CREF will be calculated on the full base salary if the participant earns 50 per cent or more of his base salary during a pay period.

1. If a participant earns less than 50 per cent of his full base salary during a pay period, no base salary deductions for TIAA/CREF or salary reductions will be reported to the Division of Pensions.

2. If a participant earns more than 50 per cent of his base salary, but less than full base salary during a pay period, the salary reduction will be calculated on base salary earned.]

(a) **Limitations concerning salary reduction agreements are:**

1. **The entry into a salary reduction agreement between an employee and his or her employing institution shall not be available to any participant during the period of time in which no employer contributions are made on his or her behalf to any retirement annuity contract.**

2. **If a participant earns less than 50 percent of his or her full base salary during a pay period, no salary reductions will be reported to the Division of Pensions.**

3. **If a participant earns 50 percent or more of his or her base salary, during a pay period, the salary reduction will be calculated on the base salary earned.**

(b) **Limitations concerning salary deductions are:**

1. **Salary deductions for TIAA/CREF will be calculated on the full base salary if the participant earns 50 percent or more of his or her base salary during a pay period.**

2. **If a person earns less than 50 percent of his or her full base salary during a pay period, no base salary deductions for TIAA/CREF will be reported to the Division of Pensions.**

(a)

## DIVISION OF PENSIONS

### Public Employees' Retirement System Ineligibility; Contributory Insurance Rates, Interfund Transfers

#### Proposed Amendments: N.J.A.C. 17:2-2.3, 3.3, 7.1 and 7.2

Authorized By: Board of Trustees of the Public Employees' Retirement System, John P. Olender, Secretary.  
Authority: N.J.S.A. 43:15A-17.

**Interested persons** may submit in writing, data, views or arguments relevant to the proposal on or before November 17, 1982. These submissions, and any inquiries about submissions and responses, should be addressed to:

John Olender, Secretary  
Public Employees' Retirement System  
Division of Pensions  
20 West Front Street  
CN 295  
Trenton, NJ 08625

The Board of Trustees of the Public Employees' Retirement System thereafter may adopt this proposal without further notice (see: N.J.A.C. 1:30-3.5). The adoption becomes effective upon publication in the Register of a notice of adoption.

This proposal is known as PRN 1982-406.

The agency proposal follows:

#### Summary

The proposed amendments concern the ineligibility of membership in the Public Employees' Retirement System, the contributory insurance rate therein and interfund transfers between other State-administered retirement systems. Such amendments are

the result of recent changes in the statutes and interpretation of the rules.

#### Social Impact

The proposed amendments will affect current and future members of the Public Employees' Retirement System as well as future public employees who apply for membership in that system.

#### Economic Impact

The proposed amendments concerning ineligible employees can affect some employees who, if they do not meet the specified requirements, will not be eligible to receive a retirement allowance. The amendments concerning contributory insurance rates will slightly increase the cost to the members in order to maintain the stated level of insurance benefits. The amendments concerning interfund transfers present no significant costs to the members but may ultimately increase their retirement allowance by permitting them service credit which they perhaps could not have transferred in the past.

**Full text** of the proposal follows (additions indicated in boldface thus; deletions indicated in brackets [thus]).

#### 17:2-2.3 Ineligible persons

(a) The following classes of persons are ineligible for membership in the system:

1.-3. (No change.)

4. [Any employee who does not earn wages in each of the four calendar quarters of a year, other than elected officials, is considered temporary or seasonal in a non-Civil Service community.] **Any employee who is provisionally appointed to a Civil Service position is considered as an employee with temporary employment status and is ineligible to establish membership until he or she receives a regular Civil Service appointment. This does not apply to anyone who is already enrolled as a member.**

5. **Seasonal employment is a category of occasional employment which the employer, consistent with past practices, does not expect to lead to permanent employment and is not a temporary position as defined under N.J.A.C. 17:2-2.4(c).**

#### 17:2-3.3 Contributory insurance rate

All participating members' contribution rate for contributory group insurance shall be [one-half] **three-quarters** of one percent of the member's base or contractual salary, effective as of [April 1, 1978] **July 1, 1981**.

OFFICE OF ADMINISTRATIVE LAW NOTE: The current text of N.J.A.C. 17:2-7.1 and 7.2, which can be found in the New Jersey Administrative Code, is to be deleted and replaced with the new text below:

## SUBCHAPTER 7. TRANSFERS

### 17:2-7.1 Interfund transfers; State-administered retirement systems

(a) **The system will transfer membership to any State-administered retirement system as follows:**

1. **A member, desiring to transfer his or her credits to any State-administered retirement system, must file an application for "Transfer of Membership Credit" in place of the customary application for withdrawal of accumulated contributions. This application will void all possible claims against the present system when approved and the new membership is commenced in the new system.**

2. **A check covering the member's accumulated contributions, full interest included, less any outstanding loan, shall be drawn**

payable to the new system for the account of the respective member. Any outstanding loan or arrears obligation will be scheduled for repayment.

3. A statement reflecting the member's status as of the date of transfer shall accompany the check.

4. The member shall enjoy the same rate of contribution and service credits established in the present system, subject to the provisions of the new system.

5. This procedure would not apply where a member does not make a timely transfer in accordance with N.J.S.A. 43:2-1 et seq. or who has been granted a deferred retirement allowance by the present system.

6. A copy of the transfer application, together with a check covering the withdrawal value and a statement of the service credits being transferred, is to be forwarded to the new system.

(b) The new system will cause to be valued the reserves accrued for such employee as compared to the reserves required in the second system.

1. If the reserves accumulated or provided for in the present system are less than those required in the new system, the full reserve will be transferred.

2. If the reserves accumulated or provided for in the present system are more than those required in the new system, only the amount required to establish the credit will be transferred.

(c) Years of credit will be subject to the benefit formula of the new system after transfer.

(d) The member will contribute to the new system at a rate based on his or her age at the time of enrollment in the present system and no refund of pension contributions will be made except for those contributions made by veterans covering service prior to January 1, 1955, where applicable.

**(a)**

**DIVISION OF PENSIONS**

**Public Employees' Retirement System  
Beneficiary Designation and Purchases and  
Eligible Service**

**Proposed Amendments: N.J.A.C. 17:2-3.12  
and 17:2-5**

Authorized By: Board of Trustees of the Public Employees' Retirement System, John P. Olender, Secretary.  
Authority: N.J.S.A. 43:15A-17.

Interested persons may submit in writing, data, views or arguments relevant to the proposal on or before November 17, 1982. These submissions, and any inquiries about submissions and responses, should be addressed to:

John Olender, Secretary  
Public Employees' Retirement System  
Division of Pensions  
20 West Front Street  
CN 295  
Trenton, NJ 08625

The Board of Trustees of the Public Employees' Retirement System thereafter may adopt this proposal without further notice (see: N.J.A.C. 1:30-3.5). The adoption becomes effective upon publication in the Register of a notice of adoption.

This proposal is known as PRN 1982-405.

The agency proposal follows:

**Summary**

The proposed amendments concern beneficiary designations and

purchases and eligible service within the Public Employees' Retirement System.

N.J.A.C. 17:2-3.12 is being amended to specify that when a person is a member of more than one retirement system (a multiple member) he or she must file new beneficiary forms so that the beneficiary nominations on the multiple enrollment forms coincide. The amendment also requires that beneficiaries must be named and explains who is included in the definition of children.

N.J.A.C. 17:2-5 has been updated as a result of statutory or policy changes, and the text has been grammatically corrected. New substantive provisions include temporary service purchases, optional purchases, and corrections of errors in purchases.

**Social Impact**

Present and future members of the Public Employees' Retirement System will be affected by these proposed amendments if they wish to designate a beneficiary or purchase previous eligible service credit for retirement purposes.

**Economic Impact**

The proposed amendments concerning beneficiary designations will have no appreciable, adverse economic effect upon the members of the PERS. The proposed amendments concerning purchases and eligible service may result in additional pension payments for those eligible members who qualify for the purchase of previous eligible service credit but the purchase of those service credits during the members' working years may result in increased retirement benefits when such members retire.

Full text of the proposal follows (additions indicated in boldface thus; deletions indicated in brackets [thus]).

17:2-3.12 Beneficiary designation; pension contributions

(a) Only a primary and a contingent designation of beneficiary may be made by the member for the payment of [his] **such member's** accumulated pension contributions.

(b) **Multiple members of a retirement system are required to file new beneficiary forms when the beneficiary nomination on the multiple enrollment forms do not agree.**

(c) All beneficiaries must be specifically named. The designation "children", unless otherwise qualified by the member, shall mean all individuals, including natural or adopted children, entitled to take from the member by the New Jersey laws of intestate succession, N.J.S.A. 3A:2A-1 et seq., and excludes all persons who are only stepchildren, foster children, grandchildren or anymore remote descendants.

**SUBCHAPTER 5. PURCHASES AND ELIGIBLE SERVICE**

17:2-5.1 Eligibility for purchase

(a) Only active contributing members of the system shall be eligible to make application for purchase of credit.

(b) In order to be eligible to purchase temporary service, a member must submit a written request to purchase service within one year from the date his or her initial pension contributions are certified to begin and such purchase must be authorized by the member before the expiration date indicated on the quotation letter.

OFFICE OF ADMINISTRATIVE LAW NOTE: Delete the current text of 17:2-5.2 (Purchase terms) as found in the New Jersey Administrative Code and substitute the following, 17:2-5.2-5.6.

**17:2-5.2 New enrollment purchase or rate adjustment**

(a) **Members who file an application for enrollment and who indicate they want to purchase the period between their regular appointment and their compulsory date of enrollment will have**

such purchase calculated on the basis of their net pension rate of contribution and salary as of their date of their regular appointment. If more than one year has elapsed from the date of compulsory enrollment, the purchase of all service will be based on the member's current salary times the full pension rate of contribution.

(b) Upon enrollment or reenrollment, a veteran shall contribute at the percent rate applicable to the age resulting from the subtraction of his or her years of prior service (pre-1955) from the date he or she began his or her present employment or the date of enrollment, whichever is later, provided that the member submits satisfactory evidence of prior public employment in New Jersey.

#### 17:2-5.3 Reestablishing military leave credit

Any veteran who terminated membership before January 1, 1955, and whose withdrawal of contributions included contributions paid by his or her employer during a period of military leave, shall receive veteran prior service credit for only the period during which he or she actually contributed. He or she can receive additional membership credit for the period of military leave if he or she redeposits the amount of employer contributions, plus regular interest to the date of his or her authorization of such purchase.

#### 17:2-5.4 Compulsory purchase

(a) An employee who was required to enroll and whose application was filed beyond his or her compulsory date of enrollment, will be required to purchase membership credit retroactive to the date of compulsory enrollment. Purchases will be calculated on the basis of the member's current salary at the full pension rate of contribution assigned as of his or her compulsory date of enrollment with regular interest.

(b) Veterans, who were ineligible to establish membership in a local contributory pension fund and who elect to enroll in accordance with the provisions of Chapter 71, P.L. 1966, must agree, prior to their enrollment, to purchase all continuous public employment with the same employer since January 1, 1955, or the date of their regular appointment. The purchase of service will be calculated on the basis of their current salary multiplied by the actuarial factor established for the member's age at the time of purchases.

#### 17:2-5.5 Optional purchases of eligible service

(a) Members, who purchase temporary service, must purchase all such service immediately preceding enrollment. The purchase will be calculated on the basis of the member's current salary times the full percentage rate of contribution assigned at enrollment.

(b) The types of purchases indicated below will be calculated on the basis of the actuarial factor established for the member's age at the time of the purchase times his or her current salary:

1. All former membership credit with another State-administered retirement system;
2. All former service with any other employer which was not certified for membership but which would have qualified on a compulsory basis at the time the service was rendered;
3. Leaves of absence:
  - i. All of the period of the leave for personal reasons which does not exceed two months;
  - ii. All of the period of the leave up to two years for personal illness or maternity.
4. Non-veterans may purchase all continuous service subsequent to the date their employer adopted the retirement system, provided the service was with the same employer to the date of enrollment;
5. Non-veterans, hired prior to July 1, 1966, whose employers have not adopted the retirement system, may enroll any time and purchase all continuous service retroactive to July 1, 1966, provided the service was with the same employer to the date of enrollment;

6. Members who purchase all or a portion of their eligible out-of-state service.

(c) Rules concerning the purchase and/or conversion of Class A credit include the following:

1. The cost of Class B service credit is based on the actuarial factors and such factors provide a retirement benefit which is one-sixth greater than service credited as Class A. If Class A credit is purchased, the cost will be six-sevenths of the amount computed for a Class B purchase. The computation is based on the member's present salary multiplied by the actuarial factor for the member's age at the time of purchase with regular interest.

2. If a Class A member converts to Class B, he or she will contribute an additional one-sixth of the total contributions that would have been payable based on his or her full Class A contribution rate with regular interest.

#### 17:2-5.6 Methods of payment

(a) Methods of payment include the following:

1. Lump sum;
2. Partial lump sum of \$250.00 or more; balance by extra payroll deductions;
3. Extra deductions equal to at least one-half of the full regular pension deduction for a maximum period of 10 years. Class A to Class B conversions, compulsory and temporary service purchases must be liquidated by age 60; if such person has attained the age of 58 or more at the time of purchase, only two years will be specified for payment;
4. Extra payroll deductions will include regular interest for the term of the installment.

#### [17:2-5.3] 17:2-5.7 Military leave

Any active member purchasing credit for out-of-state public employment, may include in the maximum of 10 years' credit to be purchased, his or her leave of absence for military service, provided he or she received credit for such leave in the State or local public retirement system, in which he or she was participating at the time he or she was in military service.

#### [17:2-5.4] 17:2-5.8 Per diem credit

For the purpose of granting prior service credit for service performed on a per diem basis, credit shall be prorated and granted on the basis of 20 days equals one month of credit.

#### [17:2-5.5] 17:2-5.9 Ineligible service

(a) Members will not be granted prior service or membership credit for the following [service] employment:

1. Honorary positions, without salary;
2. Leaves of absence without pay, except military leave;
3. Motor Vehicle Agents or as employees of the agent;
4. Licensing Agents of the Division of Fish, Game and Shellfisheries or as employee of the agent.

#### [17:2-5.6] 17:2-5.10 Creditable service; law enforcement officers

Two percent service credit for Law Enforcement Officer members is that service rendered in the capacity of a Law Enforcement Officer, for which the member has paid at the Law Enforcement Officer rate of contribution unless as otherwise provided by the statute.

#### [17:2-5.7] 17:2-5.11 Eligible credit

(a) An active, contributing member may purchase credit for up to 10 years of out-of-state public employment provided the member is not receiving nor is entitled to receive a retirement allowance for such service from any other public retirement system and proof is received that he or she has withdrawn from such other system.

(b) Federal service [or] and service rendered outside of the United

States, with the exception of eligible service rendered in certain instances in territories or possessions of the United States, Washington, D.C. and the Canal Zone, is not creditable.

**17:2-5.12 Correction of errors**

Credit for all previous service established under the provisions of Chapter 104, P.L. 1974, shall be calculated on the basis of salaries received during the period of such service. The pension rate of contribution will be determined as of the member's compulsory date of enrollment. The members shall pay on the basis of his or her current salary at the full pension rate of contribution with regular interest.

**TREASURY-TAXATION**

**(a)**

**DIVISION OF TAXATION**

**Transfer Inheritance Tax  
Pre-audit Payment of Inheritance Tax**

**Proposed Amendment: N.J.A.C. 18:26-8.7**

Authorized By: Sidney Glaser, Director, Division of Taxation.

Authority: N.J.S.A. 54:50-1.

Interested persons may submit in writing, data, views or arguments relevant to the proposal on or before November 17, 1982. These submissions, and any inquiries about submissions and responses, should be addressed to:

William R. Mulholland  
Superintendent  
Inheritance Tax Bureau  
Division of Taxation  
West State and Willow Streets  
Trenton, NJ 08646

The Division of Taxation thereafter may adopt this proposal without further notice (see: N.J.A.C. 1:30-3.5). The adoption becomes effective upon publication in the Register of a notice of adoption.

This proposal is known as PRN 1982-408.

The agency proposal follows:

**Summary**

The Director of the Division of Taxation, pursuant to N.J.S.A. 54:50-1, proposes to amend N.J.A.C. 18:26-8.7. The current rule provides the taxpayer or his legal representative with a fast and convenient way to process an estate through the New Jersey Transfer Inheritance Tax Bureau. A procedure has been established which removes filing delays and expedites the issuance of transfer inheritance tax waivers. This is known as the "L-5" program. The proposed amendment increases from \$200,000 to \$250,000 the gross estates which may fill pre-audits pursuant to the L-5 program. Reference to marital deductions is being deleted since it is no longer applicable as a result of the Transfer Inheritance Tax Act.

**Social Impact**

The whole purpose of the L-5 program which is described by N.J.A.C. 18:26-8.7 is to provide the taxpayer or his legal representative with a fast, convenient way to process an estate through the New Jersey Transfer Inheritance Tax Bureau. Until the program was instituted, the average processing and audit time for all taxable estates was about six months. Under the L-5 program, the response time to the taxpayer is less than one week. The responses from attorneys, bank officers and laymen has been most

favorable and substantial good will has been created for the Division of Taxation, Department of the Treasury, State of New Jersey. The proposed amendments will specifically impact on future estates between \$200,000 and \$250,000.

**Economic Impact**

Whether the amendment to N.J.A.C. 18:26-8.7 will cause any economic impact is uncertain. Since the purpose of the L-5 program is to remove filing delays and thus expedite the waiver process, this procedure may eliminate inconvenience and economic hardships which the taxpayer could suffer if the regular filing and audit process were used.

Full text of the proposal follows (additions indicated in boldface thus; deletions indicated in brackets [thus]).

**18:26-8.7 Pre-audit payment of inheritance tax**

(a) Where the gross estate of a resident decedent is [**\$200,000**] **\$250,000** or less, the representative of the estate may file form L-2 or L-3 (see N.J.A.C. 18:26-9.4(a)2 and 3) together with a certified or cashier's check in full payment of the tax and interest, if any, as computed by the taxpayer on form L-5, and immediately receive necessary waivers, unless the distribution or valuation of the estate involves:

- [1. Marital deduction; or
  - [2.] **1.** Closely held corporation; or
  - [3.] **2.** Inter-vivos trust; or
  - [4.] **3.** Contingencies requiring compromise.
- (b) (No change.)

# RULE ADOPTIONS

## AGRICULTURE

### (a)

#### DIVISION OF ANIMAL HEALTH

#### Brucellosis Control and Eradication Brucellosis Testing for Intrastate Movement

#### Adopted New Rule: N.J.A.C. 2:2-2.19

Proposed: August 16, 1982 at 14 N.J.R. 865(a).  
Adopted: September 28, 1982 by Arthur R. Brown, Jr.,  
Secretary, Department of Agriculture.  
Filed: September 29, 1982 as R.1982 d.360, **without  
change.**

Authority: N.J.S.A. 4:5-93.22.

Effective Date: October 18, 1982.

Summary of Public Comments and Agency Responses:  
**No comments received.**

## EDUCATION

### (b)

#### STATE BOARD OF EDUCATION

#### Vocational Education Safety Standards

#### Adopted Amendment: N.J.A.C. 6:53

Proposed: June 21, 1982 at 14 N.J.R. 619(a).  
Adopted: September 8, 1982 by State Board of Education,  
Saul Cooperman, Secretary.  
Filed: October 1, 1982 as R.1982 d.368, **with technical  
changes** not requiring additional public notice and  
comment (see N.J.A.C. 1:30-3.5).

Authority: N.J.S.A. 18A:4-15, 18A:33-1 et seq., 18A:40-  
12.2 and 18A:54-1 et seq.

Effective Date: October 18, 1982.

Summary of Public Comments and Agency Responses:  
**No comments received.**

Full text of the changes between proposal and adoption follows  
(additions to proposal shown in boldface with asterisks **\*thus\***;  
deletions from proposal shown in brackets with asterisks **\*[thus]\***).

#### 6:53-1.1 Scope and purpose [FOREWORD]

The following rules and regulations prescribed and approved by  
the State Board of Education pursuant to N.J.S.A. 18A:4-15,  
18A:33-1 et seq., 18A:40-12.2 and **\*[18A:54.1]\* \*18A:54-1\*** et  
seq. provide safety standards to govern the use of tools, machines,  
equipment and protective devices in vocational education programs  
and courses.

#### 6:53-1.[1]2 Definitions

...  
"NFPA" means the National Fire Protection Association, [470  
Atlantic Avenue, Boston,] **Batterymarch Park, \*[Quincy]\* \*  
Quincy, \*Massachusetts [02210] 02269.**  
...

#### 6:53-5.6 Radial arm saws

(a)-(b) (No change from proposal.)

(c) Ripping and ploughing shall be against the direction in which  
the cutting device rotates. The direction of the arbor rotation shall  
be conspicuously marked on the upper guard. In addition, a  
permanent label not less than 1 1/2 inches by 3/4 [inches] **inch** shall  
be affixed to the guard at the end of the guard at which the blade  
teeth exit the upper guard during the operation of the saw. The label  
shall read as follows: "Danger: Do Not Rip or Plough From **\*[this]\*  
\*This\* End.**" Such a label should be colored standard danger red.

(d)-(e) (No change from proposal.)

#### 6:53-6.2 Arc welding and cutting systems

(a) (No change from proposal.)

(b) Rules concerning the installation of arc welding equipment are  
as follows[.]:

1.-2. (No change from proposal.)

3. Supply connections and conductors:

i. A disconnecting switch or controller shall be provided at or near  
arc welding machines which are not equipped with such a switch  
or controller[,] mounted as an integral part of the machine. The  
switch shall be in accordance with NFPA **\*[N.]\* \*No.\* 70-  
[1975]1978, [as revised, ] "National Electrical Code."** Overcurrent  
protection shall be provided as specified in NFPA No. 70-  
[1975]1978, [as revised,]"National Electrical Code." A disconnect  
switch with overload protection or equivalent disconnect and  
protection means, permitted by NFPA No. 70-[1975]1978, [as  
revised,] "National Electrical Code," shall be provided for each  
outlet intended for connection to a portable welding machine. (See  
**N.J.A.C. 6:53-6.2(a)4.**)

ii.-iii. (No change from proposal.)

(c) (No change from proposal.)

## ENVIRONMENTAL PROTECTION

### (a)

#### DIVISION OF COASTAL RESOURCES

##### Coastal Resource and Development Policies

##### Notice of Correction: N.J.A.C. 7:7E-5.5

An error appeared in the April 19, 1982 issue of the New Jersey Register at 14 N.J.R. 387 concerning coastal resource and development policies. N.J.A.C. 7:7E-5.5(a)2iii should have appeared as follows (additions indicated in boldface **thus**).

7:7E-5.5 Development potential

.....  
 -residential development at densities of at least one dwelling unit per **two** acres.  
 .....

### (b)

#### DIVISION OF WATER RESOURCES

##### Water Pollution Control Construction of Wastewater Treatment Facilities

##### Adopted New Rule: N.J.A.C. 7:14-2

Proposed: January 18, 1982 at 14 N.J.R. 75(a).  
 Adopted: September 20, 1982 by Robert E. Hughey,  
 Commissioner, Department of Environmental  
 Protection.

Filed: September 22, 1982 as R.1982 d.338, **with  
 substantive and technical changes** not requiring  
 additional public notice and comment (see N.J.A.C.  
 1:30-3.5).

Authority: N.J.S.A. 58:10A-4, 58:10A-5(d), 58:25-8.

Effective Date: October 18, 1982.

##### Summary of Public Comments and Agency Responses:

General: These regulations should apply only to the construction of facilities funded by EPA/DEP, not to the construction of all wastewater facilities.

Response: The problems addressed by these regulations are not unique to grant-funded projects. By adoption of these regulations, the State is seeking to assure consistent practices on all projects. (Exceptions are provisions which relate to the grant-eligibility of certain costs.) The language of the regulations has been modified from the proposal to make it more clear that the regulations apply to all projects.

##### 7:14-2.4 Record drawings

Comment: Contractors should be required to maintain record drawings in the field to assure that field changes are reported to the owner.

Response: The owner has ultimate responsibility for record

drawings. Of course, the owner may request that a contractor provide record information during the progress of the work; the language of the regulation has been supplemented to clarify this point.

##### 7:14-2.5 Permits

Comment: Contractors should obtain all local and county permits, and be responsible for compliance therewith, by way of an established working relationship with officials.

Response: In the past there has been considerable confusion regarding who should be responsible for obtaining permits, resulting in delay, increased cost, and litigation. This regulation seeks to resolve that confusion. Certain local/county permits are required by law to be acquired by the contractor (for example, explosives, road opening, traffic control). The regulation has been modified to provide for these exceptions.

##### 7:14-2.7 Field layout (baseline and monuments)

Comment: Contractors should be required to cross-check field controls.

Response: While the owner/engineer must establish field controls in the first instance, the contractor must base his field layout on at least two points to protect against shifted or wrong control points. The language of the regulation has been changed to make this clear.

##### 7:14-2.10 Payments to contractors

Comment: This rule intrudes on the owner's prerogative by precluding retainage after completion of the project.

Response: This rule seeks to require timely payment for those portions of a project which are complete while the total project remains incomplete. An owner may retain a percentage of payment between substantial (operational) completion and total completion.

##### 7:14-2.11 Mobilization

Comment: Mobilization adds no real value to a project and should be spread over the entire value of the work.

Response: While the value of mobilization may be spread over the entire work, the cost of mobilization is incurred at a specific time. The contractor should be entitled to timely recompense for this cost.

##### 7:14-2.12 Bid items for sewer pipe installation

Comment: The State should not require that specific bid items be included in a contract.

Response: It is not the intent of this regulation to require that all the listed bid items be included in a contract, rather that when such bid items are anticipated and called for in the specifications, uniform itemization and units of measure will be used by all bidders.

##### 7:14-2.13 Reasonable minimum unit prices

Comment: Requiring minimum unit prices is an intrusion on the owner's prerogatives, and will not effectively resolve the problem of unbalanced bids.

Response: The purpose of this regulation is to mandate uniformity in the unit pricing of certain indeterminate bid items and avoid the practice of "unbalanced" bidding. The regulation has been changed from the proposal by requiring the owner (as opposed to a representative committee) to establish minimum unit prices, retaining the prerogative of the owner.

**Full text** of the changes between proposal and adoption follows (additions to proposal shown in boldface with asterisks **\*thus\***; deletions from proposal shown in brackets with asterisks \*[thus]\*).

CHAPTER 14  
WATER POLLUTION CONTROL ACT

SUBCHAPTER 2. CONSTRUCTION OF WASTEWATER  
TREATMENT FACILITIES

7:14-2.1 Construction procedures

\*[(a)]\* The Division shall require and adhere to the procedures identified in this section. Actions or procedures by \*[grantees]\* \*owners\*, permittees, consultants, contractors, or other persons affected by \*[N.J.A.C. 7:14-2.26 and 2.26A through M]\* \*this chapter\* which are not in accordance with this subchapter shall not be acceptable to the Division. Where applicable, the \*[Department]\* \*Division\* may grant a waiver from \*[the]\* any requirement of this subchapter upon presentation of written justification by the \*[grantee]\* \*owner, permittee\*, consultant[, ] or contractor.

(b) (Text deleted.)

\*[7:14-2.2 Bypassing]\*

(a)-(f) (Text deleted.)

\*[7:14-2.3 Transfer of new Publicly Owned Treatment Works from the Construction Grants Administration (CGA) to Enforcement and Regulatory Services (ERS)]\*

(a)-(g) (Text deleted.)

\*[7:14-2.4]\*\*7:14-2.2\* Record drawings: Collector sewers, interceptor sewers

and force mains

(a)-(b) (Text deleted.)

\*[(c)]\* \*(a)\* (No change from proposal.)

\*[(d)]\* \*(b)\* This responsibility shall not be delegated or transferred to the contractor. **The contractor shall assist the owner/engineer, by providing record information, when requested, during the progress of the work.**

\*[7:14-2.5]\*\*7:14-2.3\* Permits

(a)-(b) (Text deleted.)

\*[(c)]\* \*(a)\* \*[All]\* Federal, State, county and municipal permits required as a result of the construction activity within the delineated site shall be obtained by the owner and \*[all]\* associated fees shall be paid by the owner. **In addition, permits required for construction activities on railroad properties shall be obtained by the owner.**

\*[(d)]\* \*(b)\* Exceptions to this section shall be a permit to use explosives for rock excavation and such other permits **as specified in the special conditions of the contract documents** \*which by law are required to be obtained by the contractor\*.

(e) (Text deleted.)

\*[(f)]\* \*(c)\* The owner shall make every responsible effort to identify **all permits and fees and costs** required as a result of the construction activity in effect 60 days prior to the receipt of construction bids. This responsibility may be delegated to the owner's engineer with adequate compensation for this service. The engineer shall be held harmless from any penalty or action resulting from the failure to obtain a permit where every reasonable effort has been made by the engineer to obtain such permits. **All conditions** \*Conditions\* made a part of any permit shall be imposed upon the contractor as described in the contract or bid documents. **All additional** \*Additional\* costs associated with a permit resulting from the construction activity which is beyond that stipulated in the contract shall be the responsibility of the contractor.

\*[(g)]\* \*(d)\* (No change from proposal.)

\*[(h)]\* \*(e)\* The Department **of Environmental Protection** shall reserve the right to **may** intercede and assist in the resolution of any problems resulting from the acquisition of any permits.

\*[7:14-2.6]\*\*7:14-2.4\* Easements/\*[right-of-way]\*  
rights-of-way\*

(a)-(b) (Text deleted.)

\*[(c)]\* An interruption of construction or an extension of contract time may be a basis for a claim by a contractor for additional cost when such interruption or extension is caused by the **grantee** owner's inability to obtain an easement/right-of-way. Claims shall include any reasonable cost incurred by the contractor and shall be reviewed and approved by the **grantee** owner prior to submission **of** **to** the Department **of Environmental Protection**. The Department may approve all, any portion, or deny the cost for eligibility **for projects funded** under the Grant Program.

\*[7:14-2.7]\*\*7:14-2.5\* Field layout (baseline and monuments)

(a)-(b) (Text deleted.)

\*[(c)]\* The owner shall be responsible to establish **and confirm** field controls prior to start of construction. The contractor shall not be liable to check the accuracy of **its** field controls (baseline and monuments) for sewer pipe installation. **However, the contractor's layout must be based on a minimum of two field control points.** Whenever the contractor detects an error in the field controls during **the** pipe installation, the contractor shall immediately notify the owner and the owner's engineer of such error with sufficient documentation. The contractor shall be held responsible for all corrective measures and associated costs for failure to notify the owner of such error.

\*[7:14-2.8]\*\*7:14-2.6\* Engineer design activities: Plan scale and plan updating

(a)-(b) (Text deleted.)

\*[(c)]\* \*(a)\* (No change from proposal.)

\*[(d)]\* \*(b)\* (No change from proposal.)

\*[(e)]\* \*(c)\* Construction plans for sewerage facilities shall be updated whenever the bid advertisement date exceeds one year after approval by the responsible State **of** **or** Federal regulatory agency. The engineer shall receive adequate compensation for updating plans and specifications **,** and such additional cost shall be grant eligible to the extent permitted under the U.S. Environmental Protection Agency (USEPA) Regulations and Program Guidance\*. All such revisions shall be noted and dated on the plans prior to bid.

[7:14-2.9]\*\*7:14-2.7\* Construction, overhead, and profit factors for Extra Work compensation

(a)-(b) (Text deleted.)

\*[(c)]\* \*(a)\* The contractor is entitled to all identifiable direct job costs associated with Extra Work excluding subcontractor's costs. For Extra Work not in excess of \$10,000 the contractors may add up to 10 percent overhead factor to their identifiable direct job costs, but excluding the cost of any subcontracting\*, **plus up to a 10 percent profit factor to their identifiable direct costs plus overhead amount.**

\*[(d)]\* \*(b)\* As general policy, these overhead and profit factors may be accepted by **grantees** \*owners\* as reasonable in lieu of requiring the submission of additional supporting data. However, the **grantee** \*owner\* must reserve its right to review any cost or profit element on a case-by-case basis, where the submission for overhead and profit is **in** excess of the 10 percent overhead and 10 percent profit indicated above.

\*[(e)]\* \*(c)\* (No change from proposal.)

\*[(f)]\* \*(d)\* For Extra Work in the amount of \$10,000 to \$100,000, the above factors may be included initially for equitable adjustments but will be subject to **the** negotiation, cost and pricing data, and **grantee** \*owner\* review requirements **of** 40 CFR 35.938-5 (including all subsequent amendments and supplements), which rule is hereby incorporated and adopted as part of this section\*. **Federally funded projects will be governed by Federal regulations.**

**ADOPTIONS**

**\*[7:14-2.10]\* \*7:14-2.8\*** Payments to contractors  
(a)-(b) (Text deleted.)

**\*(c)\* \*(a)\*** At least 20 days before each monthly progress payment falls due for approval (but not more often than once per month), the contractor will submit to the engineer\*[s]\* a partial payment estimate filled out and signed by the contractor covering the work performed during the period covered by the partial payment estimate and supported by such data as the engineer may reasonably require. Where any specific item(s) in the partial payment estimate is in dispute, the engineer may delete those costs from the estimate and approve the acceptable portion of the payment request. Payment requested for stored materials and/or equipment shall be subject to the following conditions being met or satisfied:

1. (No change from proposal.)
2. The materials and/or equipment shall be stored in such manner that they will not be damaged due to **\*[whether]\* \*weather\***, construction operations or any other cause.
- 3.-4. (No change from proposal.)

**\*(d)\* \*(b)\***The contractor warrants and guarantees that title to all work, materials, and equipment covered by an Application for Payment\*,\* whether incorporated in the project or not, will pass to the owner upon the receipt of such payment by the contractor free and clear of all lien, claims, security interests or encumbrances (except 10 percent **\*(\*)** retention which may be withheld from suppliers and subcontractors to guarantee completion and performance). The engineer will after receipt of each partial payment estimate **\*,[\*]** either indicate in writing his approval of payment and present the partial payment estimate to the owner, or return the partial payment estimate to the contractor indicating in writing his reasons for refusing to approve payment. In the latter case, the contractor may make the necessary corrections and resubmit the partial payment estimate. **\*[After review and approval of the partial payment estimate by the owner, at the]\* \*The owner shall review the partial payment estimate at its\*** next regularly scheduled meeting **\*[the progress]\* \*and, if approved,\*** payment shall be made available to the contractor within five days. The owner shall retain not more than two percent of the amount of each payment claimed. **\*In accordance with EPA regulations, prime contractors are also required to make prompt payment to subcontractors and suppliers for eligible construction, material, and equipment costs. Generally, payments of all valid subcontractor and supplier requests for payment should be satisfied prior to the next succeeding request for progress payment by the prime contractor.\***

**\*(e)\* \*(c)\*** When the work is substantially complete (Operational or Beneficial Occupancy), the withheld amount shall be further reduced below two percent but not less than twice the current market value of the work yet to be completed. On completion and acceptance of a part of the work on which the price is stated separately in the Contract Documents, payment shall be made in full including retained percentages, less authorized deductions. The contractor or owner may **\*[appeal to the New Jersey]\* \*request assistance and guidance from the\*** Department **\*[of Environmental Protection for assistance and guidance]\*** on disputes regarding retainage.

**\*(f)\* \*(d)\* \*Substantial completion\*\*\*** as used in **\*the\*** context of this **\*[policy]\* \*section\*** shall mean satisfactory completion of major portions of the contract work, including inspection and testing, so that the facility may be turned over to the owner for its intended use **\*/[\*]** or occupancy. The engineer shall certify the date of substantial completion and that date shall establish the beginning date of the warranty/guarantee period unless a prior date has been established.

**\*[7:14-2.11]\* \*7:14-2.9\*** Mobilization: **\*[Sewerage]\* \*Unit price contracts for sewer\* construction**  
(a)-(b) (Text deleted.)

**ENVIRONMENTAL PROTECTION**

**\*(c)\* \*(a)\* \*Mobilization shall consist of the cost of initiating the contract. Payment for mobilization will be made at the lump sum price bid for this item in the proposal, which price shall include the cost of initiating the contract.\*** The provisions for payment for the item mobilization supersede any provisions elsewhere in the specifications for including the costs of these initial services and facilities in the prices bid for the various items scheduled in the proposal. **\*[The lump sum price bid for mobilization shall be payable to the contractor whenever he shall have completed 10 percent of the work of the contract. For the purpose of this item, 10 percent of the work shall be considered completed when the total of payments earned, exclusive of the amount bid for the various items scheduled in the proposal.]\*** The lump sum price bid for mobilization shall be payable to the contractor whenever he shall have completed 10 percent of the work of the contract. For the purposes of this item, 10 percent of the work shall be considered completed when the total of payments earned, exclusive of the amount bid for this item, shown on the monthly certificates of the approximate quantities of work done, shall exceed 10 percent of the total price bid for the contract.

**\*(d)\* \*(b)\*** The lump sum price bid for mobilization is limited to the following maximum amounts:

Original Contract Amount (including Mobilization)		Maximum Amount for Item of Mobilization
From More Than	To and Including	
\$ 0	\$ 100,000	\$ 3,000
100,000	500,000	15,000
500,000	1,000,000	30,000
1,000,000	2,000,000	60,000
2,000,000	3,000,000	90,000
3,000,000	4,000,000	120,000
4,000,000	5,000,000	125,000
5,000,000	6,000,000	150,000
6,000,000	7,000,000	175,000
<b>*(8)* *7*,000,000</b>	10,000,000	200,000
10,000,000	—	<b>*[250,000]*</b>
		<b>*2.5% of Amount Bid*</b>

**\*[7:14-2.12]\*\*7:14-2.10\*** **\*[Minimum breakdown of bid]\* \*Bid\* items for sewer pipe installation**

(a) This section establishes **\*[the minimum breakdown of]\* bid items **\*[for sewer pipe installation.]\* \*which shall be included in unit price contracts for sewer pipe installation where applicable.\*****

(b)-(c) (Text deleted.)

**\*(d)** Items listed below are the minimum breakdown of bid items for sewer pipe installation.]\*

Description	Unit of Measure
1.-4. (No change.)	
5. Wood Sheeting (install and remove where shown on plans)	Square Feet or 1000 <b>*[Broad]* *Board* Feet</b>
6. Wood Sheeting (left in place where shown on plans)	Square Feet or 100 <b>*[Broad]* *Board* Feet</b>
7. Steel Sheeting <b>*(install and remove where shown on plans)*</b>	Square Feet or Tons
8.-12. (No change.)	

**\*[7:14-2.13]\*\*7:14-2.11\*** Reasonable minimum unit prices

(a) This section establishes reasonable minimum unit prices for indeterminate items **\*[in this policy]\* \* , where applicable,\*** for sewer pipe installation. Indeterminate items are those items which may be anticipated and for which quantities cannot be determined.

(b)-(c) (Text deleted.)

\*(d)\* \*(b)\* [The prices established are reasonable minimum unit prices for the following bid items:]\* **The reasonable minimum unit prices are to be established by the owner/engineer for the following items:**\*

1. Stone Foundation;
2. Select Material;
3. Concrete Cradle or [Equipment]\* **Encasement**–Nonreinforced;
4. Concrete Cradle or Encasement–Reinforced;
5. Test Pits;
6. Rock Excavation;
7. **Wood** Sheeting[, Wood in Place (1,000 bf)]\* **(install and remove)–square feet or 1000 board feet\***;
8. **Wood** Sheeting[, Wood in & out (1,000 bf)]\* **(left in place)–square feet or 1000 board feet\***;
9. **Steel** Sheeting[, Steel in Place (tons)]\* **(install and remove)–square feet or tons\***;
10. **Steel** Sheeting[, Steel in & out (tons)]\* **(left in place)–square feet or tons\***.

[7:14-2.14]\*\*7:14-2.12\*\*[Eligible payment]\* **Payment**\* widths, trench backfill and roadway paving **for federally funded sewer projects**\*

(a) This section establishes [the grant]\* eligible payment widths for select fill used for trench backfill\*[,]\* and roadway [paving]\* **pavement for federally funded sewer projects**\*.

(b) (Text deleted.)

\*(c)\* \*(b)\* Select trench backfill [pavement]\* **payment**\* width:

1. Select trench backfill will be eligible for grant funding when the excavated material is totally or partially unacceptable for reuse as trench backfill. When the unacceptable material must be replaced with approved select backfill in a trench with a depth of 10 feet or less from the top of the pipe, the eligible payment width shall be Bd as shown below. For trenches of a greater depth the maximum eligible payment width shall be Bd plus H/2 for the depth of unsuitable material as measured at the time of excavation.

2. When trench width is less than Bd plus H/2, the actual width shall control the payment.

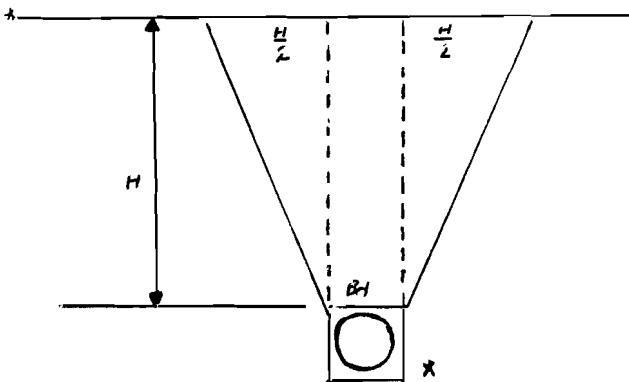

3.–4. (No change from proposal.)

\*(d)\* \*(c)\* Paving:

1. Maximum eligible payment width shall be the disturbed width plus two feet. In no case shall the maximum eligible payment width be greater than Bd plus H;

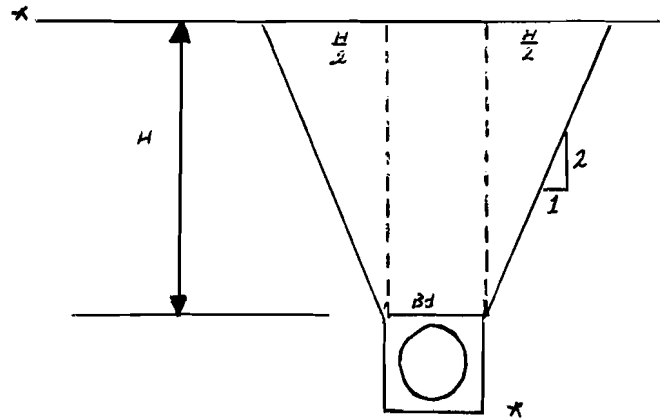

2.–3. (No change from proposal.)

\*(e)\* \*(d)\* Application of this [policy]\* **section**\* will be mandatory for all [Step 2]\* Federal Grants awarded, pursuant to the provisions of the Federal Clean Water Act **(33 U.S.C. 1251 et seq)**\* as amended, after the date of adoption **of this subchapter**\*.

(f) (Text deleted.)

(a)

**DIVISION OF FISH, GAME AND WILDLIFE**

**Fish and Game Council  
1982-83 Game Code**

**Adopted Amendments: N.J.A.C. 7:25-5.13,  
5.28 and 5.29**

Proposed: August 16, 1982 at 14 N.J.R. 871(a).  
Adopted: September 28, 1982 by Anthony DiGiovanni,  
Chairman, Fish and Game Council.  
Filed: September 28, 1982 as R.1982 d.351, **without change**.

Authority: N.J.S.A. 13:1B-30 et seq. and 23:1-1 et seq.  
Effective Date: October 18, 1982.

**Summary of Public Comments and Agency Responses:  
No comments received.**

(b)

**DIVISION OF FISH, GAME AND WILDLIFE**

**Shellfisheries  
Taking of Oysters**

**Adopted Amendment: N.J.A.C. 7:25-7.10**

Proposed: June 21, 1982 at 14 N.J.R. 629(a).

**ADOPTIONS**

Adopted: September 2, 1982 by Robert E. Hughey, Commissioner, Department of Environmental Protection. Filed: September 22, 1982 as R.1982 d.337, **without change**.

Authority: N.J.S.A. 50:1-5.

Effective Date: October 18, 1982.

Summary of Public Comments and Agency Responses: **No comments received.**

**HEALTH**

**(a)**

**DRUG UTILIZATION REVIEW COUNCIL**

**Interchangeable Drug Products**

**Adopted Amendment: N.J.A.C. 8:71**

Proposed: January 4, 1982 at 14 N.J.R. 22(a).  
Adopted: September 30, 1982 by the Drug Utilization Review Council, Robert G. Kowalski, Chairman.  
Filed: October 30, 1982 as R.1982 d.371, **with a portion of the proposal not adopted but still pending, and a portion of the proposal not adopted.**

Authority: N.J.S.A. 24:6E-6g.

Effective Date: October 18, 1982.

Summary of Public Comments and Agency Responses:

Regarding Furosemide: Hoechst-Roussel opposed the proposal to include Cord's furosemide in the New Jersey generic Formulary because (1) the Cord product's tests were done in healthy subjects and (2) Cord sells no 80 mg furosemide dosage form, so the potential arises that a patient might receive two 40 mg Cord tablets in place of one 80 mg Lasix tablet. The Drug Utilization Review Council notes that testing of most generic products is routinely done on normal volunteers, not in ill persons, and that any pharmacist who would substitute two 40 mg tablets for one 80 mg would be acting in contravention of the New Jersey generic law.

Regarding dexamethasone: MSD commented that the FDA lists all dexamethasone tablets as not being therapeutically equivalent to Decadron. Organon objected to the Council's requirement that dexamethasone products be the subject of a bioequivalency study, and pointed out that the FDA only required dissolution data. The Council agrees with MSD. The Council points out that it is not bound by the FDA's less stringent requirements, and since the FDA claims potential for bioinequivalency exists, a bioequivalency study will be needed to show that substitutes are clinically equivalent.

Regarding chlorthalidone: USV Laboratories opposed the proposed substitutes, stating the desirability of keeping patients on a single brand of chlorthalidone. The Council disagrees; if the substitutes are bioequivalent to each other, switching brands should cause no clinical problems.

The following products and their respective manufacturers were **not adopted**:

Chlorthalidone tabs 25, 50 mg KV (HN), Lederle  
Dexamethasone tabs 0.75 mg Bolar  
Dexamethasone tabs 0.25, 0.5, 0.75, 1.5 mg Barr  
Dexamethasone tabs 0.5, 0.75, 1.5, 4 mg Organon, Rowell

**HEALTH**

The following products and their respective manufacturers were **adopted**.

Furosemide tabs 20, 40 mg Cord  
Spironolactone tabs 25 mg Barr  
Spironolactone 25 mg/hydrochlorothiazide 25 mg tabs Chelsea  
Tolbutamide tabs 500 mg Barr

The following product and its manufacturer **was not adopted** but is **still pending**:

Sulfasalazine tabs 0.5g Chelsea

OFFICE OF ADMINISTRATIVE LAW NOTE: See the April 19, 1982 Register at 14 N.J.R. 389(c) and the June 21, 1982 Register at 14 N.J.R. 655(b) for related notices of adoption.

**(b)**

**DRUG UTILIZATION REVIEW COUNCIL**

**Interchangeable Drug Products**

**Adopted Amendment: N.J.A.C. 8:71**

Proposed: October 8, 1981 at 13 N.J.R. 654(a).  
Adopted: September 30, 1982 by the Drug Utilization Review Council, Robert G. Kowalski, Chairman.  
Filed: October 1, 1982 as R.1982 d.372, **with portions of the proposal not adopted.**

Authority: N.J.S.A. 24:6E-6g.

Effective Date: October 18, 1982.

Summary of Public Comments and Agency Responses:

On chlorpromazine: SKF Laboratories commented that the Food and Drug Administration does not consider Cord's tablets interchangeable with Thorazine. The agency agreed, as did the Drug Utilization Review Council's bioequivalency consultants.

No comments were received on chlorthalidone or spironolactone/hydrochlorothiazide.

The following products and their manufacturers were **not adopted**:

Chlorpromazine HCl tabs 25, 50 mg Cord  
Chlorthalidone tabs 25, 50 mg Barr-Bolar, Cord-Zenith  
Chlorthalidone tabs 50 mg Lemmon (Premo)  
Erythromycin estolate caps 250 mg Zenith  
Spironolactone 25 mg/hydrochlorothiazide 25 mg Barr

OFFICE OF ADMINISTRATIVE LAW NOTE: The following products and their manufacturers from this proposal were **previously adopted**. See the January 4, 1982 Register at 14 N.J.R. 45(d) and the January 18, 1982 Register at 14 N.J.R. 102(b).

Acetaminophen/Codeine 30 mg Drummer  
Aspirin/Codeine Tabs. 15, 30, 60 mg P-D  
Bethanechol Cl Tabs. 50 mg Danbury  
Butalbital/APC Tabs. Premo  
Cyproheptadine HCl Syrup 25 mg/5 ml NPC  
Cyproheptadine HCl Tabs. 4 mg Cord  
Ergoloid Mesylates S.L. Tabs. 0.5, 1.0 mg Danbury

Hydroxyzine HCl Tabs., 10, 25 mg	Chelsea
Hydroxyzine HCl Tabs. 10, 25, 50 mg	Zenith
Ibuprofen Tabs. 400 mg	Boots
Spirinolactone 25 mg/Hydrochlorothiazide 25 mg	Bolar
Sulfathiazole, Sulfacetamide, Sulfabenzamide,	
Urea Vaginal Cream	Byk-Gulden

**(a)****DRUG UTILIZATION REVIEW COUNCIL****Interchangeable Drug Products****Adopted Amendment: N.J.A.C. 8:71**

Proposed: April 19, 1982 at 14 N.J.R. 369(a).  
 Adopted: September 30, 1982 by the Drug Utilization Review Council, Robert G. Kowalski, Chairman.  
 Filed: October 1, 1982 as R.1982 d.373, **with a portion of the proposal not adopted but still pending, and a portion of the proposal not adopted.**

Authority: N.J.S.A. 24:6E-6.

Effective Date: October 18, 1982.

**Summary of Public Comments and Agency Responses:**

Regarding beclomethasone dipropionate aerosol: Glaxo supported this product's proposal, stating that this product is less in cost than Vanceril and comes in a refill size at a 10 percent cost savings. Glaxo objected to the bioequivalency report of September 7, 1982 which stated that their product has not been shown to be pharmaceutically equivalent to Vanceril. Glaxo contends that Beclovent should be the "reference product", and that it is a topical product with the same delivered dose and comparable particle size to Vanceril. The Council notes that the FDA list Beclovent as "BN" that is, possibly not pharmaceutically equivalent to Vanceril, therefore the Council desires data directly comparing both the delivered dose and particle size of Beclovent to Vanceril.

Regarding chlorhalidone (Abbott): Abbott Laboratories disagreed with the request for statistical power analysis, since statistically significant differences were seen. The Council agrees.

Regarding erythromycin ethylsuccinate susp 400/5 ml (NPC): The National Pharmaceutical Manufacturing Co. (NPC) commented that the Council had been inconsistent in that the Council had previously approved Heun-Norwood's erythromycin ethylsuccinate susp. (400/5 ml), bioequivalency data for which is even farther away from the Abbott reference product than is NPC's data. The Council agrees that NPC should not be unfairly treated and thus has decided to review all erythromycins (both in the Formulary and proposed for addition) to arrive at a consistent basis for deciding which erythromycins will be in the Formulary.

Regarding metronidazole (Zenith): Searle Laboratories objected to this proposal, citing the lack of an anaerobic infections indication in the Zenith package insert. Zenith countered with a copy of an FDA letter giving conditional approval to an anaerobic infections section in Zenith's package insert. The Council thus felt that Searle's objection was rendered moot.

Regarding sulfisoxazole tabs 0.5 g Lemmon (Premo): Lemmon notes that FDA has approved this product without requiring bioequivalency data and Lemmon supplied dissolution data in support of the bioavailability of this product. The Council reiterates its decision that it can require more stringent studies than the FDA, and requires bioequivalency studies for sulfisoxazole.

Regarding Hydrochlorothiazide/reserpine Lemmon (Premo): Lemmon notes that FDA has approved the use of this product. The Council responds as under sulfisoxazole (above).

Regarding tolbutamide tabs 0.5 g (P-D): Parke-Davis provided data to support this product. The Council wishes further data (power analyses).

The following products and their respective manufacturers **were not adopted but are still pending:**

Beclomethasone dipropionate aerosol inhalant	Glaxo
Erythromycin (E.C.) 250 mg	Abbott
Erythromycin ethylsuccinate susp 200/5 ml	Barr
Erythromycin ethylsuccinate susp 400/5 ml	NPC
Isosorbide dinitrate oral tabs 20, 30 mg	Chelsea
Tolbutamide tabs 500 mg	P.D.

The following products and their respective manufacturers **were adopted:**

Butalbital/APC caps	Cord
Chloramphenicol caps 250 mg	Zenith
Metronidazole tabs 250 mg	Zenith
Spirinolactone tabs 25 mg	Bolar

The following products and their respective manufacturers **were not adopted:**

Chlorthalidone tabs 25, 50 mg	Abbott
Chlorzoxazone/acetaminophen tab	Chelsea
Hydrochlorothiazide/reserpine 25/0.125, 50/0.125	Lemmon (Premo)

Hydroxyzine HCl, theophylline and ephedrine SO <sub>4</sub> tabs	Bolar
Spirinolactone tabs 25 mg	Zenith
Spirinolactone 25 mg/hydrochlorothiazide 25 mg tabs	Zenith
Sulfisoxazole tabs 0.5 g	Lemmon (Premo)
Trifluoperazine HCl tabs 1, 2, 5, 10 mg	Cord

OFFICE OF ADMINISTRATIVE NOTE: See the August 2, 1982 Register at 14 N.J.R. 836(a) and the September 7, 1982 Register at 14 N.J.R. 980(a) for related notices of adoption.

**(b)****DRUG UTILIZATION REVIEW COUNCIL****Interchangeable Drug Products****Adopted Amendment: N.J.A.C. 8:71**

Proposed: July 6, 1982 at 14 N.J.R. 690(a).  
 Adopted: September 30, 1982 by the Drug Utilization Review Council, Robert G. Kowalski, Chairman.  
 Filed: October 1, 1982 as R.1982 d.374, **with portions of the proposal not adopted but still pending.**

Authority: N.J.S.A. 24:6E-6g.

Effective Date: October 18, 1982.

**Summary of Public Comments and Agency Responses:**

Regarding sulfamethoxazole/trimethoprim (SMZ/TMP) tabs (Biocraft):

Biocraft commented in support of the proposal, stating that their infectious disease consultants felt that any statistical differences seen in their data were not of clinical importance. Specifically, Biocraft stated that a low statistical power for T-max is not clinically meaningful, nor are the statistically significant differences seen in the low dose product of therapeutic importance,

since SMZ/TMP has a "post-antibiotic" effect. Biocraft reiterated that the FDA categorizes SMZ/TMP as being therapeutically equivalent to Roche's Bactrim in both tablet strengths.

Roche objected to the SMZ/TMP proposal because:

(1) The Biocraft product's package insert does not list the same indications as Roche's product.

(2) The Biocraft product has not had extensive clinical testing, unlike Roche's product.

(3) The Drug Utilization Review Council's bioequivalency consultants had previously judged the Biocraft product's as inequivalent to Roche's Bactrim, and one consultant still states that there is lack of equivalence.

(4) Biocraft does not market suspension forms of the product.

The Council responds to these objections by first noting that Biocraft showed evidence of a revised package insert which now does include the same indications as Roche's product. Further, the Council was convinced by Biocraft's clinical consultant that the differences seen between the Biocraft and Roche products were of no therapeutic significance. The Council can, and has overridden a negative bioequivalency report when they are convinced that products are therapeutically equivalent despite being technically bioinequivalent. The issue of lack of suspension dosage forms is not germane to the interchangeability of Biocraft tablets for Roche's tablet forms of the product.

The New Jersey Pharmaceutical Association opposed the Biocraft products due to lack of the same indications in the package insert as in Roche's package insert. (Biocraft's insert now does include these previously missing indications, as noted above.)

The following products with their respective manufacturers were adopted:

Sulfamethoxazole 400 mg/trimethoprim 80 mg tabs	Biocraft
Sulfamethoxazole 800 mg/trimethoprim 160 mg tabs	Biocraft

All other proposed products cited at 14 N.J.R. 690(a) were not adopted but are still pending:

## **HUMAN SERVICES**

**(a)**

### **DIVISION OF MEDICAL ASSISTANCE AND HEALTH SERVICES**

#### **Pharmaceutical Services Manual Cancer Chemotherapy Injectable Drugs: Reporting Quantities Dispensed**

**Adopted Amendment: N.J.A.C. 10:51-2.6**

Proposed: August 2, 1982 at 14 N.J.R. 813(a).  
Adopted: September 21, 1982 by George J. Albanese,  
Commissioner, Department of Human Services.  
Filed: September 23, 1982 as R.1982 d.340, **without change.**

Authority: N.J.S.A. 30:4D-6b(6), 7 and 7b, 30:4D-22.

Effective Date: October 18, 1982.  
Operative Date: November 1, 1982.

Summary of Public Comments and Agency Responses:  
**No comments received.**

**(b)**

### **DIVISION OF PUBLIC WELFARE**

#### **Public Assistance Manual Legally Responsible Relatives (LRRs)**

**Adopted Amendment: N.J.A.C. 10:81-3.35**

Proposed: August 2, 1982 at 14 N.J.R. 814(a).  
Adopted: September 23, 1982 by George J. Albanese,  
Commissioner, Department of Human Services.  
Filed: September 28, 1982 as R.1982 d.352, **without change.**

Authority: N.J.S.A. 44:7-6 and 44:10-3.

Effective Date: October 18, 1982.

Summary of Public Comments and Agency Responses:  
**No comments received.**

**(c)**

### **DIVISION OF PUBLIC WELFARE**

#### **Public Assistance Manual Extension of Medicaid Benefits**

**Adopted Amendment: N.J.A.C. 10:81-8.22**

Proposed: August 16, 1982 at 14 N.J.R. 893(a).  
Adopted: September 23, 1982 by George J. Albanese,  
Commissioner, Department of Human Services.  
Filed: September 28, 1982 as R.1982 d.357, **without change.**

Authority: N.J.S.A. 44:7-6 and 44:10-3.

Effective Date: October 18, 1982.

Summary of Public Comments and Agency Responses:  
**No comments received.**

**(d)**

### **DIVISION OF PUBLIC WELFARE**

#### **Assistance Standards Handbook Relatives as a Resource**

**Adopted Amendment: N.J.A.C. 10:82-3.8**

Proposed: August 2, 1982 at 14 N.J.R. 814(b).  
Adopted: September 23, 1982 by George J. Albanese,  
Commissioner, Department of Human Services.  
Filed: September 28, 1982 as R.1982 d.353, **without change.**

Authority: N.J.S.A. 44:7-6 and 44:10-3.

Effective Date: October 18, 1982.

Summary of Public Comments and Agency Responses:  
No comments received.

(a)

## DIVISION OF PUBLIC WELFARE

### General Assistance Manual Single Persons Under Age 18

#### Adopted Amendment: N.J.A.C. 10:85-3.1

Proposed: August 2, 1982 at 14 N.J.R. 815(a).  
Adopted: September 23, 1982 by George J. Albanese,  
Commissioner, Department of Human Services.  
Filed: September 28, 1982 as R.1982 d.355, **without  
change.**

Authority: N.J.S.A. 44:8-111(d).

Effective Date: October 18, 1982.

Summary of Public Comments and Agency Responses:  
No comments received.

(b)

## DIVISION OF PUBLIC WELFARE

### General Assistance Manual Cuban/Haitian Entrant Program; Refugee Resettlement Program

#### Adopted Amendment: N.J.A.C. 10:85-8.2

Proposed: August 2, 1982 at 14 N.J.R. 815(b).  
Adopted: September 23, 1982 by George J. Albanese,  
Commissioner, Department of Human Services.  
Filed: September 28, 1982 as R.1982 d.356, **without  
change.**

Authority: N.J.S.A. 44:8-111(d).

Effective Date: October 18, 1982.

Summary of Public Comments and Agency Responses:  
No comments received.

(c)

## DIVISION OF PUBLIC WELFARE

### Medicaid Only Manual Payment of Burial and Funeral Expenses

#### Adopted Amendment: N.J.A.C. 10:94-7.5

Proposed: August 2, 1982 at 14 N.J.R. 816(a).  
Adopted: September 23, 1982 by George J. Albanese,  
Commissioner, Department of Human Services.  
Filed: September 28, 1982 as R.1982 d.354, **without  
change.**

Authority: N.J.S.A. 44:7-87.

Effective Date: October 18, 1982.

Summary of Public Comments and Agency Responses:  
No comments received.

## INSURANCE

(d)

## REAL ESTATE COMMISSION

### Use of Name or License for the Benefit of Others

#### Notice of Correction: N.J.A.C. 11:5-1.14

An error appeared in the April 5, 1982 issue of the New Jersey Register at 14 N.J.R. 345(b) concerning use of name or license for the benefit of others. N.J.A. C. 11:5-1.14(b) should have appeared as follows:

(b) [Any arrangement . . . for the benefit of another person, firm or corporation.] **Lending a broker's license for the benefit of another person, firm or corporation shall be construed as including any arrangement whereby \*[a corporation shall be construed as including any arrangement whereby]\* a corporation seeks to be licensed in, or whereby a corporation, firm, or individual uses as a business name, a name containing the name of a salesperson or broker-salesperson in, or proposed to be in, the broker's employ, which does not also contain the name of the broker or record, in the case of a corporation or the name of the employing broker, in all other cases \* [. However, if a broker buys the real estate business of a person licensed as a broker immediately proceeding the purchase and employs the former broker as a broker-salesperson or salesperson, the broker may use the name of the broker-salesperson or salesperson in a business name or corporate name which does not also contain the name of the broker.]\* \*\* with the following exceptions:**

1.-2. (No change.)

## LAW AND PUBLIC SAFETY

(e)

## DIVISION OF MOTOR VEHICLES

### Vehicle Inspection Inspection Period of Passenger Vehicles and Certain Commercial Vehicles

#### Readopted Amendment: N.J.A.C. 13:20-7.3 and 7.4

Proposed: August 16, 1982 at 14 N.J.R. 918(a).

Proposed: August 16, 1982 at 14 N.J.R. 918(a).  
 Adopted: October 1, 1982 by Clifford W. Snedeker,  
 Director of the Division of Motor Vehicles.  
 Filed: October 1, 1982 as R.1982 d.364, **without  
 change.**

Authority: N.J.S.A. 39:8-2.

Effective Date: October 1, 1982.

**Summary of Public Comments and Agency Responses:**  
**No comments received.**

**(a)**

**DIVISION OF MOTOR VEHICLES**

**Titles**  
**Application for "Title Only"**

**Adopted Repeal: N.J.A.C. 13:21-4.5**

Proposed: June 21, 1982 at 14 N.J.R. 632(a).  
 Adopted: September 17, 1982 by Clifford W. Snedeker,  
 Director, Division of Motor Vehicles.  
 Filed: October 1, 1982 as R.1982 d.370, **without  
 change.**

Authority: N.J.S.A. 39:10-4.

Effective Date: October 18, 1982.

**Summary of Public Comments and Agency Responses:**  
**No comments received.**

**STATE**

**(b)**

**OFFICE OF ADMINISTRATIVE LAW**

**Distribution and Sale of Publications**  
**New Jersey Register and New Jersey**  
**Administrative Code**

**Adopted Repeal: N.J.A.C. 15:15-8.1 and 8.2**

Proposed: April 19, 1982 at 14 N.J.R. 366(a).  
 Adopted: September 23, 1982 by Howard H. Kestin,  
 Director, Office of Administrative Law.  
 Filed: September 23, 1982 as R.1982 d.339, **without  
 change.**

Authority: N.J.S.A. 52:14F-5(f) and 52:14B-7(d)

Effective Date: October 18, 1982.

**Summary of Public Comments and Agency Responses:**  
**No comments received.**

**TREASURY-GENERAL**

**(c)**

**DIVISION OF PENSIONS**

**Administration**  
**Annual Reports of Salary Changes**

**Adopted Amendment: N.J.A.C. 17:1-1.14**

Proposed: February 16, 1982 at 14 N.J.R. 200(a).  
 Adopted: April 6, 1982 by William J. Joseph, Director,  
 Division of Pensions.  
 Filed: September 28, 1982 as R.1982 d.358, **without  
 change.**

Authority: N.J.S.A. 52:18A-96.

Effective Date: October 18, 1982.

**Summary of Public Comments and Agency Responses:**  
**No comments received.**

**(d)**

**DIVISION OF PENSIONS**

**Pensioners' Group Health Insurance Plan**  
**Amount of Coverage; Termination**

**Adopted Amendment: N.J.A.C. 17:1-1.24**

Proposed: April 5, 1982 at 14 N.J.R. 328(a).  
 Adopted: May 13, 1982 by William J. Joseph, Director,  
 Division of Pensions.  
 Filed: September 27, 1982 as R.1982 d.346, **without  
 change.**

Authority: N.J.S.A. 52:18A-96.

Effective Date: October 18, 1982.

**Summary of Public Comments and Agency Responses:**  
**No comments received.**

**(e)**

**DIVISION OF PENSIONS**

**Claims and Credit**  
**Purchase Terms**

**Adopted Amendment: N.J.A.C. 17:1-4.11**

Proposed: April 5, 1982 at 14 N.J.R. 328(b).  
 Adopted: May 13, 1982 by William J. Joseph, Director,  
 Division of Pensions.  
 Filed: September 27, 1982 as R.1982 d.347, **without  
 change.**

Authority: N.J.S.A. 52:18A-96.  
 Effective Date: October 18, 1982.

Summary of Public Comments and Agency Responses:  
**No comments received.**

**(a)**

**DIVISION OF PENSIONS**

**General Administration  
 Administrative Practices**

**Adopted New Rule: N.J.A.C. 17:1-12.1**

Proposed: April 5, 1982 at 14 N.J.R. 329(a).  
 Adopted: May 14, 1982 by William J. Joseph, Director,  
 Division of Pensions.  
 Filed: September 28, 1982 as R.1982 d.350, **without  
 change.**

Authority: N.J.S.A. 52:18A-96.  
 Effective Date: October 18, 1982.

Summary of Public Comments and Agency Responses:  
**No comments received.**

**(b)**

**DIVISION OF PENSIONS**

**Public Employees' Retirement System  
 Contributory Insurance Rates**

**Adopted Amendment: N.J.A.C. 17:2-3.3**

Proposed: February 16, 1982 at 14 N.J.R. 200(b).  
 Adopted: May 6, 1982 by Public Employees' Retirement  
 System, John Olender, Secretary.  
 Filed: September 27, 1982 as R.1982 d.343, **without  
 change.**

Authority: N.J.S.A. 43:15A-17.  
 Effective Date: October 18, 1982.

Summary of Public Comments and Agency Responses:  
**No comments received.**

**(c)**

**BOARD OF TRUSTEES OF THE  
 TEACHERS' PENSION AND ANNUITY  
 FUND**

**Administration  
 Dates of Board Meetings**

**Adopted Amendment: N.J.A.C. 17:3-1.1**

Proposed: February 16, 1982 at 14 N.J.R. 201(a).  
 Adopted: June 15, 1982 by the Board of Trustees of the

Teachers' Pension and Annuity Fund, Mary Conrey,  
 Secretary.  
 Filed: September 27, 1982 as R.1982 d.344, **without  
 change.**

Authority: N.J.S.A. 18A:66-56.

Effective Date: October 18, 1982.

Summary of Public Comments and Agency Responses:  
**No comments received.**

**(d)**

**CONSOLIDATED POLICE AND  
 FIREMEN'S PENSION FUND**

**Medical Examinations; Physicians**

**Adopted Amendment: N.J.A.C. 17:6-3.9**

Proposed: November 2, 1981 at 13 N.J.R. 749(b).  
 Adopted: March 10, 1982 by the Consolidated Police and  
 Firemen's Pension Fund Commission, Anthony P.  
 Ferrazza, Secretary.  
 Filed: September 27, 1982 as R.1982 d.349, **without  
 change.**

Authority: N.J.S.A. 43:16-7.

Effective Date: October 18, 1982.

Summary of Public Comments and Agency Responses:  
**No comments received.**

**(e)**

**DIVISION OF PENSIONS**

**Supplemental Annuity Collective Trust  
 Council  
 Qualified Voluntary Employee Contributions**

**Adopted New Rule: N.J.A.C. 17:8-4**

Proposed: June 7, 1982 at 14 N.J.R. 556(b).  
 Adopted: September 22, 1982 by the Supplemental Annuity  
 Collective Trust Council.

Filed: September 27, 1982 as R.1982 d.348, **with substantive changes** not requiring additional public notice and comment (see N.J.A.C. 1:30-3.5).

Authority: N.J.S.A. 52:18A-111.

Effective Date: October 18, 1982.

**Summary of Public Comments and Agency Responses:**

The Attorney General has advised that proposed new rule N.J.A.C. 17:8-4.2 conflicts with the statute establishing the Supplemental Collective Annuity Trust (SCAT), N.J.S.A. 52:18A-113. The proposal would permit, in addition to any contributions a participant could make to SCAT, an added contribution equal to the lesser of \$2,000 or the participant's total compensation. However, N.J.S.A. 52:18A-113 allows a maximum contribution of 10 percent of salary, therefore, the proposal exceeds the statutorily permitted amount of contribution.

Based on such advice, the proposed rule has been modified upon adoption to permit contributions of up to but not to exceed 10 percent of a participant's annual salary.

**Full text** of the changes between proposal and adoption follows (additions to proposal shown in boldface with asterisks **\*thus\***; deletions from proposal shown in brackets with asterisks **\*[thus]\***).

17:8-4.1 Qualified voluntary employee contributions

(a)-(c) (No change from proposal.)

**\*(f) Contributions made under this subchapter shall be commingled for investment purposes with voluntary contributions otherwise made under the Trust.\***

17:8-4.2 Participant contributions

(a) **\*[In addition to any contributions which the participant may elect to contribute to the Trust in accordance with N.J.A.C. 17:8-2.4, a]\* \*A\* participant may contribute during a calendar year, or if he or she so elects, on or before April 15 of the succeeding calendar year, an amount up to \$2,000 but not more than 100 percent of his or her compensation, which shall be deemed a "qualified voluntary employee contribution", as that term is defined in Section 219 of the Internal Revenue Code, with respect to the calendar year **\*[.]\* \***, **provided that the total contributions made by the participant to the Supplemental Annuity Collective Trust for all purposes does not exceed 10 percent of such participant's annual salary as stipulated in N.J.S.A. 52:18A-113.\*** The participant shall specify the amount, if any, to be contributed by payroll deduction, or he or she may make those contributions in a lump sum. The participant's qualified voluntary employee contributions shall be remitted to the Trust as soon as practicable after they are made.**

(b)-(d) (No change.)

(a)

**STATE HEALTH BENEFITS COMMISSION**

**State Health Benefits Program  
Premiums and Coverage; Ten Month  
Employees; Effective Date**

**Adopted Amendment: N.J.A.C. 17:9-5.11**

Proposed: January 4, 1982 at 14 N.J.R. 36(a).

Adopted: April 15, 1982 by State Health Benefits

Commission, William J. Joseph, Secretary.

Filed: September 27, 1982 as R.1982 d.341, **without change.**

Authority: N.J.S.A. 52:14-17.27.

Effective Date: October 18, 1982.

**Summary of Public Comments and Agency Responses:  
No comments received.**

(b)

**STATE HOUSE COMMISSION**

**Judicial Retirement System  
Insurance Coverage During Maternity Leave**

**Adopted Amendment: N.J.A.C. 17:10-3.2**

Proposed: February 16, 1982 at 14 N.J.R. 201(b).

Adopted: May 14, 1982 by Judicial Retirement System,  
William J. Joseph, Secretary.

Filed: September 27, 1982 as R.1982 d.345, **without change.**

Authority: N.J.S.A. 43:6A-29d.

Effective Date: October 18, 1982.

**Summary of Public Comments and Agency Responses:  
No comments received.**

(c)

**STATE HOUSE COMMISSION**

**Judicial Retirement System  
Medical Examinations; Physicians**

**Adopted Amendment: N.J.A.C. 17:10-5.10**

Proposed: February 1, 1982 at 14 N.J.R. 140(a).

Adopted: May 14, 1982 by the State House Commission,  
William J. Joseph, Secretary, Judicial Retirement  
System.

Filed: September 27, 1982 as R.1982 d.342, **without change.**

Authority: N.J.S.A. 43:6A-29d.

Effective Date: October 18, 1982.

**Summary of Public Comments and Agency Responses:  
No comments received.**

(a)

STATE INVESTMENT COUNCIL

State of New Jersey Cash Management Fund Guidelines on Error Correction

Adopted New Rules: N.J.A.C. 17:16-31.15

Proposed: August 16, 1982 at 14 N.J.R. 899(a).
Adopted: September 29, 1982 by State Investment Council, Roland M. Machold, Director, Division of Investment.
Filed: September 30, 1982 as R.1982 d.363, without change.

Authority: N.J.S.A. 52:18A-91.

Effective Date: October 18, 1982.

Summary of Public Comments and Agency Responses: No comments received.

(b)

STATE INVESTMENT COUNCIL

New Jersey State Employees Deferred Compensation Plan

Adopted New Rule: N.J.A.C. 17:16-44

Proposed: August 16, 1982 at 14 N.J.R. 900(a).
Adopted: September 29, 1982 by State Investment Council, Roland M. Machold, Director, Division of Investment.
Filed: September 30, 1982 as R.1982 d.362, without change.

Authority: N.J.S.A. 52:18A-91.

Effective Date: October 18, 1982.

Summary of Public Comments and Agency Responses: No comments received.

TREASURY-TAXATION

(c)

DIVISION OF TAXATION

Motor Fuels Tax Retail Sales

Adopted Amendment: N.J.A.C. 18:19-2.7

Proposed: July 6, 1982 at 14 N.J.R. 705(a).
Adopted: October 1, 1982 by Sidney Glaser, Director, Division of Taxation.
Filed: October 1, 1982 as R.1982 d.369, with substantive changes not requiring additional public notice and comment (see N.J.A.C. 1:30-3.5).

Authority: N.J.S.A. 56:6-6.

Effective Date: October 18, 1982.

Summary of Public Comments and Agency Responses:

Comments and letters received concerning the proposed rule focused upon several areas.

The most significant issue raised in comments was whether the Division should or should not establish standards for motor fuels price signs other than pump top signs. Such signs would include pole signs or street signs, for example. After review of the issues involved, it was determined to allow the Federal rules regarding such signs to be operative in this respect without adding further regulation at the present time at the State level.

Correspondence was received with respect to pricing signs at stations having more than one island. Pursuant to Formal Opinion No. 2-1982 of the New Jersey Attorney General, a determination was made to require uniform posting of the credit card price upon pumps regardless of station configuration. This would permit a uniform standard of comparison for motorists to use. The discount for cash would be calculated at the time of payment in all cases.

Notice was taken that bills are currently pending in the legislature which would authorize self-service of motor fuels in New Jersey. In the event such changes are made concerning motor fuels marketing in this State, it is conceivable that existing rules would be reviewed in light of such future changes.

Full text of the changes between proposal and adoption follows (additions to proposal shown in boldface with asterisks \*thus\*).

18:9-2.7 Posted prices and brand names; cash discounts

(a) (No change from proposal.)

(b) A retail dealer may sell similar fuels at different prices to cash and credit customers, and the price posted on top of the pump \*and on the pump meter\* shall be the credit purchase price. A conspicuous sign shall also be displayed at the pump or at the island posting the price per gallon (or per gallon and per liter) reduction for cash purchases of fuels.

(c) (No change from proposal.)

OTHER AGENCIES

(d)

GARDEN STATE PARKWAY

Off-Premise, Outdoor Advertising

Adopted New Rule: N.J.A.C. 19:8-9

Proposed: August 16, 1982 at 14 N.J.R. 901(a).
Adopted: September 28, 1982 by New Jersey Highway Authority, F. Joseph Carragher, Executive Director.
Filed: September 30, 1982 as R.1982 d.361, without change.

Authority: P.L.1981, c.463 (N.J.S.A. 27:12B-20(a)) and N.J.S.A. 27:12B-5(j)(s).

Effective Date: October 18, 1982.

Summary of Public Comments and Agency Responses: No comments received.

(a)

## CASINO CONTROL COMMISSION

## Exclusion of Persons Hearings

## Exclusion of Persons

**Adopted New Rule: N.J.A.C. 19:42-4.5**

(Alternative No. 2)

**Adopted Amendments: N.J.A.C. 19:42-4.1,  
4.2, 4.3 and 4.4****Adopted Amendments: N.J.A.C. 19:48-1.1,  
1.4, 1.5 and 1.8 (Alternative No. 2)**

Proposed: August 16, 1982 at 14 N.J.R. 904(a).

Adopted: September 28, 1982 by Casino Control  
Commission, Theron G. Schmidt, Executive  
Secretary.Filed: September 29, 1982 as R.1982 d.359, **with technical  
changes** not requiring additional public notice and  
comment (see N.J.A.C. 1:30-3.5).

Authority: N.J.S.A. 5:12-63(c) and 5:12-71.

Effective Date: October 18, 1982.

**Summary of Public Comments and Agency Responses:**

Comments were received from the Division of Gaming Enforcement. The Division recommended that Alternative I of 19:42-4.5 (found at 14 N.J.R. 905) and 19:48-1.8 (found at 14 N.J.R. 906) be adopted instead of Alternatives II. The Division advanced the position that Alternative I was consistent with Section 71(f) of the Act. The Division contended that Alternative I was more consistent with the intent of the statute in that it requires a person found to have met the criteria for exclusion at a preliminary hearing to then show cause why he should have his name removed from the list at the final hearing.

The Commission found that the interpretation of Section 71(f) advanced by Alternative II was within the scope of the statutory language and further, that this alternative represented a more equitable procedure for placing individuals on the exclusion list.

**Full text** of the changes between proposal and adoption follows (additions to proposal shown in boldface with asterisks **\*thus\***; deletions from proposal shown in brackets with asterisks \*[thus]\*).

## 19:48-1.4 Duties of the Division of Gaming Enforcement

(a) (No change from proposal.)

(b) If, [Upon] upon completion of [such] an investigation, [if] the Division [recommends the placement of a name on the exclusion list] determines that an individual should be placed on the exclusion list, the Division shall [submit a written report to the Commission setting forth the factual basis for such recommendation and the reasons] file a petition with the Commission, with supporting affidavits, identifying the candidate and setting forth a factual basis why the Division believes the [individual's presence in a casino hotel facility would be inimical to the interest of the State of New Jersey or of licensed casino gaming] candidate satisfies the criteria for exclusion established by section \*[17]\* **\*71\*** of the Act and these regulations.

(c) No change from proposal.)

# EMERGENCY ADOPTIONS

(a)

## DIVISION OF PUBLIC WELFARE

### Public Assistance Manual Rounding; Absence Due to Uniformed Service

### Adopted Emergency Amendment and Concurrent Proposal: N.J.A.C. 10:81-3.17 and 8.22

Emergency Amendment Adopted: September 23, 1982 by  
George J. Albanese, Commissioner, Department of  
Human Services.

Gubernatorial Approval (See N.J.S.A. 52:14B-4(c)):  
October 1, 1982.

Emergency Amendments Filed: October 1, 1982 as R.1982  
d.366.

Authority: N.J.S.A. 44:7-6 and 44:10-3; Tax Equity and  
Fiscal Responsibility Act of 1982; 45 CFR  
233.20(a)(3)(viii) and 233.90(c)(1)(iii).

Emergency Amendments Effective Date: October 1,  
1982.

Emergency Amendments Expiration Date: November 30,  
1982.

**Interested persons** may submit in writing, data, views or  
arguments relevant to the proposal on or before November 17,  
1982. These submissions, and any inquiries about submissions and  
responses, should be addressed to:

G. Thomas Riti, Director  
Division of Public Welfare  
CN 716  
Trenton, NJ 08625

This amendment was adopted on an emergency basis and became  
effective upon acceptance for filing by the Office of Administrative  
Law (see N.J.S.A. 52:14B-4(c) as implemented by N.J.A.C. 1:30-  
4.4). Concurrently, the provisions of this emergency amendment  
are being proposed for readoption in compliance with the normal  
rulemaking requirements of the Administrative Procedure Act  
N.J.S.A. 52:14B-1 et seq. The readopted rule becomes effective  
upon acceptance for filing by the Office of Administrative Law (see  
N.J.A.C. 1:30-4.4(d)).

This proposal is known as PRN 1982-446.

The agency emergency adoption and concurrent proposal  
follows:

#### Summary

This rule is required by the Federal Tax Equity and Fiscal  
Responsibility Act of 1982. This rule precludes AFDC eligibility  
for families whose current assistance is based on continued absence  
due to a parent being in military or uniformed service. This rule also  
extends Medicaid eligibility to families otherwise losing AFDC  
eligibility due to rounding of benefits to the next lower whole  
dollar.

#### Social Impact

An estimated 800 families will lose eligibility for AFDC. The  
provision extending Medicaid benefits to certain families is thought  
to have insignificant impact.

#### Economic Impact

The provision limiting AFDC eligibility for families in which a  
parent is in the military or uniformed service will reduce total  
assistance expenditures by a maximum of \$3 million annually. The  
provision extending Medicaid eligibility to certain families will  
have little or no economic impact.

**Full text** of the emergency adoption and concurrent proposal and  
adoption follows (additions shown in boldface **thus**; deletions  
shown in brackets [thus]).

10:81-3.17 Continued absence of parent from the home

(a)-b) (No change.)

(c) "Continued absence from the home" (see N.J.A.C. 10:81-  
2.7(d)) may be for any reason. The following are some ways to  
establish absence:

1.-3. (No change.)

4. A parent who is separated from his [ / ] or her family because  
of [military] **uniformed** service shall **not** be considered  
"continuously absent from the home" [when the nature of the  
absence is such as either to interrupt or to terminate the parent's  
functioning as a provider of maintenance, physical care or guidance  
for the child, and the known or indefinite duration of the absence  
precludes counting on the parent's performance of his/her function  
in planning for the present support or care of the child.] **if such  
absence is occasioned solely by reason of active uniformed  
service. If, however, continued absence would exist irrespective  
of performance of uniformed service, (e.g., desertion of the  
family before or after entry into uniformed service or divorce)  
eligibility for AFDC-C may be established.** Such findings shall  
be noted in the income maintenance file[.].

i. When a parent serving in the [armed forces] **uniformed services**  
is not continuously absent from the home, the family may be  
eligible under the AFDC-F or -N segment.

ii. **"Uniformed service" is defined to mean the Army, Navy,  
Air Force, Marine Corps, Coast Guard, Environmental  
Sciences Services Administration, and Public Health Service of  
the United States.**

5.-6. (No change.)

(d)-(g) (No change.)

10:81-8.22 Persons eligible for medical assistance

(a)-(c) (No change.)

(d) AFDC eligible units which receive no AFDC payments solely  
because the amount payable would be less than \$10.00, are  
eligible for Medicaid benefits. **Likewise, AFDC families which  
would be ineligible for AFDC solely because of rounding of the  
amount that would otherwise be payable, are eligible for  
Medicaid benefits.**

(a)

DIVISION OF PUBLIC WELFARE

Assistance Standards Handbook  
Rounding; Prorating; and Absence Due to  
Military Service

Adopted Emergency Amendments and  
Concurrent Proposals: N.J.A.C. 10:82-2.1,  
2.2, 2.18, 2.20, 5.3, and 5.10

Emergency Amendment Adopted: September 23, 1982 by  
George J. Albanese, Commissioner, Department of  
Human Services.

Gubernatorial Approval (see N.J.S.A. 52:14B-4(c)):  
October 1, 1982.

Emergency Amendment Filed: October 1, 1982 as R.1982  
d.367.

Authority: N.J.S.A. 44:7-6 and 44:10-3; Tax Equity and  
Fiscal Responsibility Act of 1982; 45 CFR  
233.20(a)(2)(iv), 233.20(a)(3)(viii), and  
233.90(c)(1)(iii).

Emergency Amendment Effective Date: October 1, 1982.  
Emergency Amendment Expiration Date: November 30,  
1982.

Interested persons may submit in writing, data, views or  
arguments relevant to the proposal on or before November 17,  
1982. These submissions, and any inquiries about submissions and  
responses, should be addressed to:

G. Thomas Riti, Director  
Division of Public Welfare  
CN 716  
Trenton, NJ 08625

This amendment was adopted on an emergency basis and became  
effective upon acceptance for filing by the Office of Administrative  
Law (see N.J.S.A. 52:14B-4(c) as implemented by N.J.A.C. 1:30-  
4.4). Concurrently, the provisions of this emergency amendment  
are being proposed for re-adoption in compliance with the normal  
rulemaking requirements of the Administrative Procedure Act,  
N.J.S.A. 52:14B-1 et seq. The re-adopted rule becomes effective  
upon acceptance for filing by the Office of Administrative Law (see  
N.J.A.C. 1:30-4.4(d)).

This proposal is known as PRN 1982-447.

The agency emergency adoption and concurrent proposal  
follows:

Summary

The Federal Tax Equity and Fiscal Responsibility Act of 1982  
amends the Social Security Act as it pertains to AFDC effective  
October 1, 1982. One provision of the Act requires all AFDC  
benefits, if not a whole dollar, be rounded to the next lower whole  
dollar. Additionally, the Act requires that assistance payments for  
the initial month of eligibility and additional payments be prorated  
from the date of application or eligibility. The Act also precludes  
AFDC eligibility for families based solely on the absence of a parent  
due to uniformed service.

Social Impact

Revision to the rules on rounding is expected to have  
insignificant social impact. Proration of initial months assistance  
benefits will reduce assistance benefits in first month of eligibility.  
An estimated 800 families will lose AFDC eligibility because of the  
elimination of uniformed service as a factor of continued absence.

Economic Impact

Rule on rounding assistance payments is expected to have  
insignificant economic impact. The provision prorating initial  
month's benefits will reduce total assistance expenditures  
approximately \$1.8 million. The rule concerning eligibility due to  
uniformed service will reduce total assistance expenditures an  
estimated \$3 million annually.

Full text of the emergency adoption and concurrent proposal and  
adoption follows (additions indicated in boldface thus; deletions  
indicated in brackets [thus]).

10:82-2.1 Form PA-3A or Form 105

(a) (No change.)

(b) Form PA-3A, shall be completed in the following order:

1.-3. (No change.)

4. Part II: The amount of the regular monthly grant is determined  
in Part II, Amount of Allowance. Make the appropriate entries  
according to key numbers indicated on the form as follows:

i. (No change.)

ii. The monthly grant:

(1) (No change.)

(2) [The amount of the monthly grant shall be rounded to the  
nearest dollar. (\$0.50 or above shall be carried to the next higher  
dollar.)] **If the amount of the monthly grant is not a whole  
dollar, the grant shall be rounded down to the next lower whole  
dollar.**

(3) (No change.)

(4) Even if maximum income eligibility has been established, if  
no income deficit exists (except when due solely to the recovery of  
an overpayment or because of rounding the amount which would  
**otherwise be payable**) the family is ineligible for AFDC and  
Medicaid.

5.-6. (No change.)

10:82-2.2 Initial grant

(a) When eligibility has been determined, the initial grant shall be  
computed as follows:

[1. When the grant is effective on the first through the 10th day  
of the month, the full public assistance allowance shall be used in  
determining the amount of the initial grant, and all income available  
from the date of the grant until the end of the month shall be  
considered.

2. When the grant is effective on the 11th through 20th day of the  
month, two thirds of the public assistance allowance shall be used  
in determining the amount of the initial grant, and all income  
available from the date of the grant until the end of the month shall  
be considered.

3. When the grant is effective after the 20th day of the month. 1/  
30th of the amount of the appropriate public assistance allowance  
multiplied by the number of days remaining in the month shall be  
used in determining the amount of the grant, and all income  
available from the date of the grant until the end of the month shall  
be considered.]

**1. All income available from the date of application to the end  
of the month shall be considered and the amount otherwise  
payable shall be prorated by multiplying that amount by the  
factor appropriate for date of application in the table below. If  
the result is not a whole dollar amount, the amount shall be  
rounded to the next lower whole dollar.**

Date of Application	Multiplication Factor	Date of Application	Multiplication Factor
1	1.000	16	.5000
2	.9666	17	.4666
3	.9333	18	.4333

4	.9000	19	.4000
5	.8666	20	.3666
6	.8333	21	.3333
7	.8000	22	.3000
8	.7666	23	.2666
9	.7333	24	.2333
10	.7000	25	.2000
11	.6666	26	.1666
12	.6333	27	.1333
13	.6000	28	.1000
14	.5666	29	.0666
15	.5333	30 and 31	.0333

(b)-(c) (No change.)

10:82-2.18 [Parent in military service] **Reserved**

[(a) When a parent is in the military service and his/her continuous absence from the home interrupts or terminates his/her functioning in the care and support of his/her child(ren), the family may be eligible for AFDC-C in accordance with all pertinent regulations and procedures in this handbook.

(b) When a parent in the military service is not continuously absent from the home, the family may be eligible for the AFDC-N segment, in accordance with the applicant regulations.]

10:82-2.20 Change in need while assistance is being received

(a)-(b) (No change.)

(c) **Any additional payments to an eligible unit due to a change in family circumstances are subject to proration (see N.J.A.C. 10:82-2.2) based on the date of such change.**

10:82-5.3 Child care

(a)-(b) (No change.)

(c) Further rules on child care expenses are:

1.-5. (No change.)

**6. Any AFDC child care payments authorized under this section, if not a whole dollar amount, shall be rounded down to the next lower whole dollar.**

(d)-(h) (No change.)

10:82-5.10 Emergency assistance

(a) (No change.)

(b) The following conditions must be observed with respect to all expenditures by the county welfare agency for which Federal and/or State matching is claimed under the classification of emergency assistance:

1.-2. (No change.)

**3. Any emergency assistance authorized under this section, if not a whole dollar amount, shall be rounded down to the next lower whole dollar.**

(c)-(e) (No change.)

**(a)**

**DIVISION OF PUBLIC WELFARE**

**Food Stamp Program  
Standard Utility Allowance, Maximum  
Coupon Allotment Table, and Monthly  
Coupon Allotment Formula**

**Adopted Emergency Amendments and  
Concurrent Proposal: N.J.A.C. 10:87-12.1,  
12.2, and 12.6**

Emergency Amendment Adopted: September 23, 1982 by George J. Albanese, Commissioner, Department of Human Services.

Gubernatorial Approval (see N.J.S.A. 52:14B-4(c): October 1, 1982.

Emergency Amendments Filed: October 1, 1982 as R.1982 d.365.

Authority: N.J.S.A. 30:4B-2; the Food Stamp Act of 1977, as amended (7 U.S.C. 2014); 7 CFR 273.9(d)(6)(iv), 7 CFR 273.10(e)(4); and the Omnibus Budget Reconciliation Act of 1982, H.R. 6955, Sections 143 and 144, Conference Report Number 97-759.

Emergency Amendments Effective Date: October 1, 1982.

Emergency Amendments Expiration Date: November 30, 1982.

**Interested persons** may submit in writing, data, views or arguments relevant to the proposal on or before November 17, 1982. These submissions, and any inquiries about submissions and responses, should be addressed to:

G. Thomas Riti, Director  
Division of Public Welfare  
CN 716  
Trenton, NJ 08625

This amendment was adopted on an emergency basis and became effective upon acceptance for filing by the Office of Administrative Law (see N.J.S.A. 52:14B-4(c) as implemented by N.J.A.C. 1:30-4.4). Concurrently, the provisions of these emergency amendments are being proposed for readoption in compliance with the normal rulemaking requirements of the Administrative Procedure Act, N.J.S.A. 52:14B-1 et seq. The readopted rule becomes effective upon acceptance for filing by the Office of Administrative Law (see N.J.A.C. 1:30-4.4(d)).

The proposal is known as PRN 1982-445.

The agency emergency adoption and concurrent proposal follows:

**Summary**

The Department of Human Services is mandated by Federal law and regulations to implement an updated standard utility allowance (SUA) to reflect changes seasonally in the cost of utilities. Additionally, the Department is required to revise the maximum coupon allotments to reflect the Federal adjustment increasing coupon amounts which takes into account changes in the cost of living. The monthly coupon allotment formula is being amended to comply with the Omnibus Budget Reconciliation Act of 1982, H.R. 6955, Section 143, Conference Report Number 97-759 (effective October 1, 1982) regarding a change in the rounding of net income when calculating benefit amounts.

**Social Impact**

The increase in the standard utility allowance (SUA) will benefit households claiming the SUA deduction as the new allowance reflects actual changes in utility costs. Households with utility costs in excess of the SUA may have actual expenses used in the eligibility and benefit computation. The increase in the maximum coupon allotment will increase the amount of Food Stamp benefits households are receiving. Certain households claiming the new SUA may receive an additional increase in benefits because of the increased standard deduction for the SUA. The rounding amendment in the monthly coupon allotment formula will have the effect of decreasing benefits by one dollar.

**Economic Impact**

The increase in the standard utility allowance deduction and maximum coupon allotments will offset the effect of the one dollar loss in benefits due to the new rounding procedure. The net effect of these changes will be an increase in benefits for Food Stamp recipients. These changes will not impact significantly on State and

local agencies administering the program, but will bring additional Federal funds into the State for those households participating in this Federally funded program.

Full text of the emergency adoption and proposed amendments follows (additions indicated in boldface **thus**; deletions indicated in brackets [thus]).

10:87-12.1 Income deduction table

TABLE  
Income Deductions

Standard Deduction	\$ 85.00
Child Care/Shelter Deduction	\$ 115.00
Uniform Telephone Allowance	\$ 8.36
Standard Utility Allowance	\$[179.00]
	<b>286.00</b>

10:87-12.2 Maximum coupon allotment table

TABLE II  
Maximum coupon Allotment (MCA)

Household Size	MCA
1	\$[ 70] <b>75</b>
2	[128] <b>139</b>
3	[183] <b>199</b>
4	[233] <b>253</b>
5	[277] <b>300</b>
6	[332] <b>360</b>
7	[367] <b>398</b>
8	[419] <b>455</b>
9	[472] <b>512</b>
10	[525] <b>569</b>
Each Additional Member	[53] <b>57</b>

10:87-12.6 Monthly coupon allotment

(a) The formula for determining the monthly coupon allotment follows:

1. Benefit determination without the tables: to determine the benefit households shall receive:

- i. (No change.)
- ii. Round the product [down if it ends in \$0.01 through \$0.49 and up if it ends in \$0.50 through \$0.99] **up to the next dollar if it ends in cents; then**
- iii.-v. (No change.)

# MISCELLANEOUS NOTICES

## ENVIRONMENTAL PROTECTION

(a)

### DIVISION OF WATER RESOURCES

#### Water Supply Bond Loan Regulations for the Rehabilitation of Water Supply Facilities Extension of Closing Date for Loan Applications

##### Public Notice

Robert E. Hughey, Commissioner of the Department of Environmental Protection, pursuant to N.J.A.C. 7:1A-2.5(d), hereby extends the application closing date for loans issued pursuant to the Water Supply Bond Loan Regulations for the Rehabilitation of Water Supply Facilities, N.J.A.C. 7:1A-1 and 2, from October 1, 1982 until November 1, 1982.

Any questions concerning application procedures for water supply bond loans from interested publicly owned water supply facilities should be addressed to:

Robert Oberthaler  
Water Supply and Watershed  
Management Administration  
CN 029  
Trenton, NJ 08625

Please note that the Department of Environmental Protection publishes this Public Notice as a matter of public information.

(b)

### DIVISION OF WATER RESOURCES

#### The Lower Delaware Water Quality Management Plan

##### Public Notice

Lower Alloways Creek Township has applied to the New Jersey Department of Environmental Protection (NJDEP) for an amendment to the Lower Delaware Water Quality Management Plan. Lower Alloways Creek Township has requested to be the designated Sewerage Facility Planning Agency for the Village of Hancock's Bridge, thereby removing this area from the jurisdiction of Salem County Department of Health, the Agency that has an interim designation as the Sewerage Facility Planning Agency for parts of Salem County. The Sewerage Facility Planning Agency, is provided for under the authority of the Federal "Clean Water Act" (33 U.S.C. 466 et. seq.) for the purpose of providing comprehensive sewerage facilities planning.

This notice is being given to inform the public that NJDEP has prepared an amendment to the Lower Delaware Water Quality Management Plan which was adopted pursuant to the "Water Quality Planning Act", (N.J.S.A. 58:11A-1 et seq.) and the "Clean

Water Act." This amendment changes the designated Sewerage Facility Planning Agency for the Village of Hancock's Bridge from Salem County Department of Health to Lower Alloways Creek Township. This amendment also changes the interim designation of Salem County Department of Health to a final designation.

All information dealing with the aforesaid "Water Quality Planning Act" is located at, Division of Water Resources, 25 Arctic Parkway, Trenton, New Jersey, 08625. It is available for inspection between 8:30 A.M. and 4:00 P.M., Monday through Friday.

Interested persons may submit written comments on the amendment to Mr. George Horzepa, Chief, Bureau of Planning and Standards, at the address cited above. All comments must be submitted within 30 days of the date of this public notice. All comments submitted by interested persons in response to this notice, within the time limit, shall be considered by the NJDEP with respect to the amendment request.

Any interested person may request in writing that NJDEP hold a nonadversarial public hearing on the amendments. This request must state the nature of the issues to be raised at the proposed hearing and must be submitted within 30 days of the date of this public notice to Mr. Horzepa, at the address cited above. If a public hearing is held, the public comment period in this notice shall automatically be extended to the close of the public hearing.

(c)

### DIVISION OF WATER RESOURCES

#### Petition for Rulemaking Water Supply Extension and Construction Orders

##### Petitioner: Department of the Public Advocate

Authority: N.J.S.A. 52:14B-(4)f and N.J.A.C. 1:30-3.6.

Take notice that the Department of Environmental Protection (DEP) has received a petition for rulemaking, pursuant to N.J.S.A. 52:14B-4(f), from the New Jersey Department of the Public Advocate (DPA). As required by N.J.A.C. 1:30-3.6, notice is hereby given of that petition.

The petition requests that the DEP develop criteria and procedures for issuing orders to extend public water systems to service citizens whose drinking water has been contaminated. The petition requests that certain specific concerns be considered in the course of such rulemaking. These concerns are set forth below:

1. Mandatory findings that private well water is no longer potable and is not economically practicable or technologically feasible for the well owner to use an alternative private water supply;
2. The health, environmental and economic factors upon which the findings referred to in paragraph 1 will be based;
3. A mandatory record analysis of alternative sources of water supply with reasons for their being unacceptable;
4. The economic factors which must be considered in determining whether it is feasible to extend the water system under consideration;
5. A mandatory record analysis of the economic feasibility of extending the system at issue and reasons for the decision on feasibility;

6. A requirement that the BPU make a positive finding on the economic feasibility of extending a water utility system before a DEP order may issue;

7. Provisions for early notice to and input by the BPU and Public Advocate in cases involving BPU regulated utilities, and by governing bodies or a utility authority, as relevant, in cases of public water systems other than those regulated by the BPU;

8. A required local public hearing, with public comments and agency responses on the record;

9. A mandatory written report indicating the basis of a final DEP decision;

10. An opportunity for a plenary hearing before an Administrative Law Judge at the request of an interested party, preferably before a final DEP order, or at the very least, to appeal such an order.

The DEP agrees that rulemaking should be considered in the area of problems associated with the State governments' response in cases of contaminated drinking water. The scope of consideration of rulemaking should be somewhat broader than that requested by the Public Advocate.

Initially, petition for rulemaking should have been filed with the Board of Public Utilities, as well as this Department, since rulemaking by the Board is vital to insuring that comprehensive consideration of the public interest is made in the course of decision-making.

Secondly, the DEP believes that orders to extend public water supply are only one type of governmental action which may result from a water contamination problem. Orders to construct a new water supply system and orders requiring interim water supply are among the agency actions which might be required, additional to extension orders. In the course of consideration, the DEP intends to address the wider scope, which these matters suggest.

The Department will be preparing regulations to address the subject matters in this Notice and will work the Board of Public Utilities and the Department of the Public Advocate throughout the development of the regulatory documents.

This is a notice of petition for a rule (see N.J.A.C. 1:30-3.6). Any rule concerning the subject of this notice of petition for a rule must comply with the rulemaking requirements of the Administrative Procedure Act, N.J.S.A. 52:14B-1 et seq.

(a)

**THE COMMISSIONER**

**State Certifications of Draft NPDES Permits**

**Public Notice**

Robert E. Hughey, Commissioner of the Department of Environmental Protection, pursuant to the "New Jersey Water Pollution Control Act," N.J.S.A. 58:10A-1 et seq., is authorized to assess compliance of a surface water discharge with State law pertaining to discharges to the waters of the State. The Department is requested by the United States Environmental Protection Agency, as required by section 401 of the Federal Clean Water Act, 33 U.S.C. 1251 et seq., to certify that a discharge, as described in a draft National Pollutant Discharge Elimination System permit, will not violate the requirements of State law.

The Department publishes public notice of certifications in the DEP Bulletin. Copies of the Bulletin may be obtained by calling (609) 292-3178 or writing to the Documents Distribution Center, P.O. Box 1390, Trenton, New Jersey 08625.

**LAW AND PUBLIC SAFETY**

(b)

**DIVISION OF MOTOR VEHICLES**

**Bulk Commodities Application**

**Public Notice**

**Take notice** that Clifford W. Snedeker, Director, Division of Motor Vehicles pursuant to the authority of N.J.S.A. c39:5-E.11, hereby list the names and addresses of applicants who have filed an application for a common carrier's certificate of public convenience and necessity and/or a contract carrier permit to engage in the business of transporting bulk commodities in intrastate commerce.

**COMMON CARRIER (NON GRANDFATHER)**

Karo Enterprises, Inc.  
P.O. Box 3178  
Plainfield, NJ 07063

Bulk Petroleum Haulers  
246 S. Grand St.  
Hammonton, NJ 08037

Lee Transport, Inc.  
RD 1 Garden Rd.  
Box 520  
Elmer, NJ 08318

Any or all the above applications may be inspected in full by interested parties at the office of the Division of Motor Vehicles, Bureau of Motor Carriers, 25 S. Montgomery Street, Trenton, New Jersey 08666, on business days between 9:00 A.M. and 4:00 P.M.

Protests in writing and verified under oath may be presented by interested parties to the Director of Motor Vehicles within 20 days following the publication date of an application.

**OTHER AGENCIES**

(c)

**CASINO CONTROL COMMISSION**

**Petition for Rulemaking  
Entertainment within Casino Room**

Petitioner: Marina Associates.  
Authority: N.J.S.A. 5:12-69(c).

**Take notice** that on September 15, 1982, the Casino Control Commission received a petition for rulemaking pursuant to N.J.S.A. 5:12-69(c) from Marina Associates.

Marina Associates has requested the repeal of N.J.A.C. 19:52-1.4(c) pursuant to N.J.S.A. 5:12-69(c) and for relaxation of N.J.A.C. 19:52-1.4(c) pursuant to N.J.A.C. 19:40-1.3(d). N.J.A.C. 19:52-1.4(c) provides that entertainment may not be offered within a casino room. Petitioner submits that this

prohibition is too broad, in that it inhibits creative and nondisruptive entertainment within Atlantic City casinos.

This petition will be considered by the Casino Control Commission at a regularly scheduled public meeting in conformity with N.J.S.A. 5:12-69(c).

Statement of Ownership, Management and Circulation (Act of August 12, 1970: Section 3685, Title 39, United States Code.)

1. Title of publication: NEW JERSEY REGISTER. A. Publication number 442950. 2. Date of filing: October 1, 1982. 3. Frequency of issue: twice each month. A. Number of issues published annually: 24. B. Annual subscription price: \$40 controlled circulation; \$75 first class. 4. Location of known office of publication: 88 East State Street, CN 301, Trenton, NJ 08625. 5. Location of general business offices of the publishers: 88 East State Street, CN 301, Trenton, NJ 08625. 6. Names and addresses of publisher, editor, managing editor: Publisher: Janice T. Demarest, 88 East State Street, CN 301, Trenton, NJ 08625. Editor: Norman Olsson, 88 East State Street, CN 301, Trenton, NJ 08625. Managing Editor: none. 7. Owner Name: Office of Administrative Law, State of New Jersey, Administrative Publications, 88 East State Street, CN 301, Trenton, NJ 08625. 8. Known bondholders, mortgages, and other security holders owning or holding one percent or more of total amount of bonds, mortgages or other securities: none. 9. Purpose, function, and nonprofit status of this publication and the exempt status for Federal income tax purposes: has not changed during preceding 12 months. 10. Average no. copies each issue during preceding 12 months: A. Total no. copies printed: 3,100. B. Paid circulation: 1. Sales through dealers and carriers, street vendors and counter sales: none. 2. Mail subscriptions: 2,200. C. Total paid circulation: 2,200. D. Free distribution by mail, carrier, or other means, samples, complimentary, and other free copies: 563. E. Total distribution (sum of C and D): 2,783. F. Copies not distributed: 1. Office use, leftover, unaccounted, spoiled after printing: 317. 2. Returns from news agents: none. G: Total (sum of E and F should equal net press run shown in A): 3,100. Actual number of copies of a single issue published nearest to filing date: A. Total no. copies printed: 3,450. B. Paid circulation: 1. Sales through dealers and carriers, street vendors and counter sales: none. 2. Mail subscription: 2,321. C. Total paid circulation: 2,321. D. Free distribution by mail, carrier, or other means, samples, complimentary, and other free copies: 563. E. Total distribution (sum of C and D): 2,884. F. Copies not distributed: 1. Office use, leftover, unaccounted, spoiled after printing: 566. 2. Returns from news agents: none. G. Total (sum of E and F should equal net press run shown in A): 3,450. 11. The statements made by me above are correct and complete: Janice T. Demarest, Publisher.

# INDEX OF PROPOSED RULES

The *Index of Proposed Rules* contains rules which have been proposed in the New Jersey Register between October 8, 1981 and October 4, 1982, and which have not been adopted and filed by October 1, 1982. The index does not contain rules proposed in this Register and listed in the *Table of Rules in This Issue*. These proposals will appear in the next *Index of Proposed Rules*.

A proposed rule listed in this index may be adopted no later than one year from the date the proposal was originally published in the Register. Failure to timely adopt the proposed rule requires the proposing agency to re-submit the proposal and to comply with the notice and opportunity-to-be-heard requirements of the Administrative Procedure Act (N.J.S.A. 52:14B-1 et seq.) as implemented by the Rules for Agency Rulemaking of the Office of Administrative Law (N.J.A.C. 1:30).

The *Index of Proposed Rules* appears in the second issue of each month, complementing the *Index of Adopted Rules* which

appears in the first Register of each month. Together, these indices make available for a subscriber to the Code and Register all legally effective rules, and enable the subscriber to keep track of all State agency rulemaking activity from the initial proposal through final promulgation.

The proposed rules are listed below in order of their Code citation. Accompanying the Code citation for each proposal is a brief description of its contents, the date of its publication in the Register, and its Register citation.

The full text of the proposed rule will generally appear in the Register. If the full text of the proposed rule was not printed in the Register, it is available for a fee from:

Administrative Filings  
CN 301  
Trenton, New Jersey 08625

N.J.A.C. CITATION		PROPOSAL DATE	PROPOSAL NOTICE (N.J.R. CITATION)
<b>ADMINISTRATIVE LAW—TITLE 1</b>			
1:1-2.2	Contested cases and OAL jurisdiction	6-7-82	14 N.J.R. 486(a)
1:1-2.2	Public hearing: Contested cases and OAL jurisdiction	6-7-82	14 N.J.R. 674(a)
1:1-5.2, 5.3	Pre-hearing information	6-21-82	14 N.J.R. 607(a)
1:1-9.7	Interlocutory review	8-2-82	14 N.J.R. 778(a)
1:1-17.3	Return of cases	1-4-82	14 N.J.R. 4(b)
1:6A	Special Education Program hearing rules	9-7-82	14 N.J.R. 930(a)
1:20	Representation fee hearings before PERC Appeal Board	8-16-82	14 N.J.R. 862(a)
1:30	Agency rulemaking	8-2-82	14 N.J.R. 780(a)
<b>BANKING—TITLE 3</b>			
3:1-2.20	Savings and loan branch facilities	11-2-81	13 N.J.R. 714(a)
3:6-9	Super NOW deposit accounts	8-2-82	14 N.J.R. 786(a)
<b>CIVIL SERVICE—TITLE 4</b>			
4:1-7.11	Hours of work and compensation	9-7-82	14 N.J.R. 938(a)
4:1-12.10	Notifying eligibles of certification	9-7-82	14 N.J.R. 940(a)
4:1-15.2	Lateral title change	9-7-82	14 N.J.R. 940(b)
4:1-16.1-16.5	Layoffs and demotions	2-16-82	14 N.J.R. 184(a)
4:1-16.1-16.5	Senate Concurrent Resolution: Layoffs and demotions	2-16-82	14 N.J.R. 298(a)
4:1-18.2, 18.6-18.8	Hours of work and compensation	9-7-82	14 N.J.R. 938(a)
4:1-18.4	Repeal dual employment rules	9-7-82	14 N.J.R. 941(a)
4:1-24.1, 24.3-24.12	Layoffs and demotions	2-16-82	14 N.J.R. 184(a)
4:1-24.1, 24.3-24.12	Senate Concurrent Resolution: Layoffs and demotions	2-16-82	14 N.J.R. 298(a)
4:1-25.1	Public inspection of records	9-7-82	14 N.J.R. 942(a)
4:2-7.1	Compensation for NL4 designated titles	2-16-82	14 N.J.R. 184(a)
4:2-7.1	Repeal: Hours of work	9-7-82	14 N.J.R. 938(a)
4:2-15.2	Repeal: Lateral title change	9-7-82	14 N.J.R. 940(b)
4:2-16.1, 16.2	Senate Concurrent Resolution: Layoffs and demotions	2-16-82	14 N.J.R. 298(a)
4:2-18.4	Repeal dual employment rules	9-7-82	14 N.J.R. 941(a)
4:2-20.12	Repeal: Public inspection of records	9-7-82	14 N.J.R. 942(a)
4:3-16.1, 16.2	Layoffs and demotions	2-16-82	14 N.J.R. 184(a)
4:3-16.1, 16.2	Senate Concurrent Resolution: Layoffs and demotions	2-16-82	14 N.J.R. 298(a)
4:3-18.1	Repeal dual employment rules	9-7-82	14 N.J.R. 941(a)
<b>COMMUNITY AFFAIRS—TITLE 5</b>			
5:23-2.38, 4.15, 4.26, 5.2, 5.9, 5.11	Uniform Construction Code: Licensing	7-19-82	14 N.J.R. 734(a)
5:23-4.8	Interlocal Construction Code enforcement	6-7-82	14 N.J.R. 495(a)
5:23-4.17, 4.20	UCC enforcing agency fees	9-7-82	14 N.J.R. 943(a)
5:25-5.5	Warranty coverage claims	9-7-82	14 N.J.R. 944(a)
5:27-1.6, 2.1	Multi-building rooming and boarding houses	10-4-82	14 N.J.R. 1075(b)

<b>N.J.A.C. CITATION</b>		<b>PROPOSAL DATE</b>	<b>PROPOSAL NOTICE (N.J.R. CITATION)</b>
5:27-2.1	Fire safety in boarding houses	6-7-82	14 N.J.R. 496(b)
5:27-3.5	Boarding houses: Non-ambulatory residents	6-7-82	14 N.J.R. 499(a)
5:27-4.8, 5.1-5.3, 5.8, 5.9	Fire safety in boarding houses	6-7-82	14 N.J.R. 496(b)
5:27-10.6	Boarding houses: Self-administration of medicine	6-7-82	14 N.J.R. 499(a)
5:27-12	Boarding house safety improvement loans	6-7-82	14 N.J.R. 496(b)
5:30-10.1, 10.2	Local Finance Board: Municipal port authorities	8-2-82	14 N.J.R. 786(b)
5:80-2	Housing Finance Agency project conversions	4-5-82	14 N.J.R. 301(b)
<b>EDUCATION—TITLE 6</b>			
6:11-3.12, 4.7	County substitute certification: School nurse, athletic coach	9-20-82	14 N.J.R. 1010(a)
6:11-4.2, 4.3, 4.4	Temporary, provisional and emergency certificates	9-20-82	14 N.J.R. 1011(a)
6:11-8.1, 8.2, 8.4, 8.8, 8.9-8.13	Minimum standards for teacher education	4-5-82	14 N.J.R. 305(a)
6:11-10.2, 10.4, 10.7-10.9	Administrative certification	6-21-82	14 N.J.R. 614(a)
6:29-6.3	County substitute certification: Athletic coach	9-20-82	14 N.J.R. 1010(a)
<b>ENVIRONMENTAL PROTECTION—TITLE 7</b>			
7:1A-3	Emergency interim repair of water systems	10-4-82	14 N.J.R. 1075(b)
7:1G	Loan procedures: Water supply interconnections	9-20-82	14 N.J.R. 1012(a)
7:7-2.2, 2.6-2.9, 2.11, 2.15	"Repair" of waterfront structures; removal of unauthorized fill; permit duration	7-6-82	14 N.J.R. 679(b)
7:7F	Shore Protection Program	8-16-82	14 N.J.R. 865(b)
7:8	Storm water management	12-21-81	13 N.J.R. 916(a)
7:8	Storm water management	9-20-82	14 N.J.R. 1022(a)
7:11-2, -4	Rate Schedule: Water from Delaware and Raritan, Spruce Run/Round Valley	7-6-82	14 N.J.R. 681(a)
7:13-1.11	Notice of flood hazard delineations	12-21-81	13 N.J.R. 950(a)
7:13-1.11	Delineated streams in Somerset County	4-19-82	14 N.J.R. 367(a)
7:13-1.11	Floodway delineations along Big Timber Creek, Delaware basin	6-7-82	14 N.J.R. 505(a)
7:13-1.11	Floodway delineations along Pond Run, Mercer County	6-7-82	14 N.J.R. 506(a)
7:13-1.11	Floodway delineations along Cedar Creek, Lacey Twp.	7-6-82	14 N.J.R. 683(a)
7:13-1.11	Floodway delineations within Bass River Basin	7-6-82	14 N.J.R. 683(b)
7:13-1.11	Floodway delineations within Atlantic Basin	7-19-82	14 N.J.R. 736(a)
7:13-1.11	Floodway delineations in Union County	8-16-82	14 N.J.R. 870(a)
7:13-1.11	Floodway delineations in Morris County	8-16-82	14 N.J.R. 870(b)
7:13-1.11	Floodway delineations in Essex County	9-20-82	14 N.J.R. 1027(a)
7:14A-1.8, 1.9	Fee schedule for NJPDES permittees	7-6-82	14 N.J.R. 684(a)
7:25-6	1983-84 Fish Code	8-16-82	14 N.J.R. 872(a)
7:25-9.1	Taking of hard clams: Size tolerance control	7-6-82	14 N.J.R. 689(a)
7:25-12.1	Sea clam fishery (early opening)	11-16-81	13 N.J.R. 843(a)
7:25-12.1	Sea clam harvest	8-16-82	14 N.J.R. 881(a)
7:25-15.1	Relay of hard clams (with Emergency Adoption)	9-20-82	14 N.J.R. 1055(a)
7:25-16.1	Upstream fishing lines	8-16-82	14 N.J.R. 882(a)
7:25-22.1	Marine finfish: Menhaden season	9-7-82	14 N.J.R. 945(a)
7:26-1.4, 2.9, 2.13	Sanitary landfill closure	8-16-82	14 N.J.R. 883(a)
7:26-6	Interdistrict and intradistrict solid waste flow	9-20-82	14 N.J.R. 1027(b)
7:26-7.4, 7.5, 8.15	Waste oil management as hazardous material	1-4-82	14 N.J.R. 20(a)
7:27-9.1	Emission averaging and high sulfur fuels	12-7-81	13 N.J.R. 870(a)
7:28-24	Licensing of nuclear medicine technologists	6-7-82	14 N.J.R. 507(a)
7:30	State Pesticide Control Code	8-2-82	14 N.J.R. 787(a)
7:30	Pesticide Control Code: Extension of comment period	9-7-82	14 N.J.R. 946(a)
<b>HEALTH—TITLE 8</b>			
8:21-3.24	Ingredients for human self-defense sprays	9-20-82	14 N.J.R. 1029(a)
8:24	Retail food establishments; vending machines	6-7-82	14 N.J.R. 509(a)
8:31A-7	SHARE Manual: 1983 rate review guidelines	8-16-82	14 N.J.R. 887(a)
8:31B-3	Hospital rate setting: RIM and other 1983 changes	7-19-82	14 N.J.R. 737(a)
8:31B-3	New comment period: RIM Methodology	7-19-82	14 N.J.R. 1103(a)
8:31B-4.44, 4.66	1983 Financial Elements and Reporting	9-7-82	14 N.J.R. 946(b)
8:42-2	Residential and inpatient drug treatment facilities	8-2-82	14 N.J.R. 812(a)
8:43A-9.4, 9.7, 9.11	Drug abuse treatment centers	6-7-82	14 N.J.R. 529(a)
8:65-10.1, 10.2	Rescheduling of Methaqualone	9-20-82	14 N.J.R. 1029(b)
8:70-1.4	Resubmission of rejected generic drug products	9-20-82	14 N.J.R. 1030(a)
8:71	Additions to generic drug list (see 14 N.J.R. 389(c), 14 N.J.R. 655(b), 14 N.J.R. 1159(a))	1-4-82	14 N.J.R. 22(a)
8:71	Additions to generic drug list (see 14 N.J.R. 836(a), 14 N.J.R. 1160(a))	4-19-82	14 N.J.R. 369(a)

<b>N.J.A.C. CITATION</b>		<b>PROPOSAL DATE</b>	<b>PROPOSAL NOTICE (N.J.R. CITATION)</b>
8:71	Additions to generic drug list (see 14 N.J.R. 1160(b))	7-6-82	14 N.J.R. 690(a)
8:71	Steri-med 50mg hydrochlorothiazide tabs	8-16-82	14 N.J.R. 887(b)
8:71	Generic drug list additions	8-16-82	14 N.J.R. 888(a)
8:71	Generic drug list deletions	9-20-82	14 N.J.R. 1030(b)
8:71	Additions to generic drug list	10-4-82	14 N.J.R. 1077(a)
<b>HIGHER EDUCATION--TITLE 9</b>			
9:1-1.6	Branch campuses and off-campus facilities	4-19-82	14 N.J.R. 370(a)
9:2-2.25	Mandatory retirement at State colleges	9-7-82	14 N.J.R. 947(a)
9:4-1.2, 2.14	Branch campuses and off-campus facilities	4-19-82	14 N.J.R. 370(a)
9:11-1	Educational Opportunity Fund Program	7-6-82	14 N.J.R. 691(a)
9:12-1, -2	Educational Opportunity Fund Program	7-6-82	14 N.J.R. 691(a)
<b>HUMAN SERVICES--TITLE 10</b>			
10:44A	Group homes and supervised apartments for developmentally disabled	6-7-82	14 N.J.R. 531(a)
10:49-1.4	Personal care services	7-6-82	14 N.J.R. 695(a)
10:49-1.23	Documentation of services by Medicaid providers	11-2-81	13 N.J.R. 738(b)
10:49-1.27	LTC: "Field audit" defined	9-20-82	14 N.J.R. 1031(a)
10:51-1.2	Non-legend device addition	4-5-82	14 N.J.R. 320(a)
10:51--App. B, D	Non-legend device addition	4-5-82	14 N.J.R. 320(a)
10:51-3.14, 5.18	Pharmaceutical payment in long-term care	6-7-82	14 N.J.R. 542(a)
10:54-3	Nurse-midwifery services	8-16-82	14 N.J.R. 889(a)
10:55-1.1, 1.2, 1.7, 1.9	Prosthetic and orthotic "approved" providers defined	9-20-82	14 N.J.R. 1032(a)
10:56-1.14, 1.15, 3.4	Limitation on diagnostic dental services	12-7-81	13 N.J.R. 875(a)
10:58	Nurse-midwifery services	8-16-82	14 N.J.R. 889(a)
10:63-1.4	Long-term care consultation and services	11-2-81	13 N.J.R. 740(a)
10:63-1.16	Long-term care of psychiatric patients	11-16-81	13 N.J.R. 813(a)
10:63-1.16	Agency response to petition: Long-term care of psychiatric patients	4-5-82	14 N.J.R. 321(a)
10:63-1.22	LTC: "Field audit" defined	9-20-82	14 N.J.R. 1031(a)
10:63-3.2	LTC: Related-party lease costs	7-19-82	14 N.J.R. 742(a)
10:63-3.10	LTC: Capital Facilities Allowance rate	7-19-82	14 N.J.R. 743(a)
10:63-3.20	Long-term care facilities: Reimbursement appeals	3-15-82	14 N.J.R. 269(a)
10:64	Hearing aid services revisions	10-8-81	13 N.J.R. 656(a)
10:66-1.2, 1.3, 1.6, 1.7	Ambulatory surgical centers	7-6-82	14 N.J.R. 697(a)
10:66-1.6, 3.3	Personal care services	7-6-82	14 N.J.R. 695(a)
10:81-2.6, 2.17, 2.18, 3.1, 3.5, 3.11, 3.13, 3.18, 8.23-8.25	PAM: AFDC changes	10-4-82	14 N.J.R. 1078(a)
10:81-4.5-4.11, 4.13, 4.14, 4.16, 4.18, 4.19	PAM: Vendor payments	9-20-82	14 N.J.R. 1034(a)
10:81-6.17, 7.18	PAM: Replacement of checks	4-19-82	14 N.J.R. 373(a)
10:81-7.13	PAM: Request and Authorization for Records Disposal	9-7-82	14 N.J.R. 947(b)
10:81-10	PAM: Refugee Resettlement and Cuban/Haitian Entrant Programs	9-7-82	14 N.J.R. 948(a)
10:82	ASH: Federal requirements	9-7-82	14 N.J.R. 952(a)
10:82-5.10	ASH: Return of child from foster care placement	7-6-82	14 N.J.R. 698(a)
10:83	Repeal Medical Assistance for Aged	10-4-82	14 N.J.R. 1081(a)
10:85-3.1, 3.3	GAM: AFDC ineligible	12-21-81	13 N.J.R. 926(a)
10:85-3.2	GAM: Verification of unemployment/disability benefits	9-7-82	14 N.J.R. 956(a)
10:85-3.3	GAM: Members of household	8-16-82	14 N.J.R. 893(b)
10:85-3.3	GAM: Residential health care rates	8-16-82	14 N.J.R. 894(a)
10:85-3.4	GAM: AFDC ineligible	12-21-81	13 N.J.R. 926(a)
10:85-5.1	MWD use of General Assistance funds	11-16-81	13 N.J.R. 814(a)
10:85-5.6, 8.4	GAM: Dialysis treatments	5-3-82	14 N.J.R. 420(b)
10:87-2.4, 2.7, 2.8, 2.34, 3.2, 3.12, 4.4, 4.19, 7.16, 7.17, 9.7	Extension of food stamp eligibility	9-20-82	14 N.J.R. 1037(a)
10:87-2.7, 3.15-3.21	Food stamp participants and job search	9-20-82	14 N.J.R. 1041(a)
10:87-9.16	Replacement of food stamp benefits	10-4-82	14 N.J.R. 1081(b)
10:89-3.1	Home Energy Assistance: Automatic payments	9-7-82	14 N.J.R. 957(a)

<b>N.J.A.C. CITATION</b>		<b>PROPOSAL DATE</b>	<b>PROPOSAL NOTICE (N.J.R. CITATION)</b>
10:90	Monthly reporting by AFDC units and food stamp households	9-7-82	14 N.J.R. 958(a)
10:94-9	Medical Assistance for Aged Continuation	10-4-82	14 N.J.R. 1084(a)
10:122-4.1,4.3, 4.4-4.7	Child care centers: Staff requirements	8-2-82	14 N.J.R. 816(b)
10:122-4.1	Head and group teachers in child care centers	3-1-82	14 N.J.R. 223(a)
10:122-4.3-4.6	Head and group teachers in child care centers	3-1-82	14 N.J.R. 223(a)
10:122-5.1-5.4	Standards for child care centers	1-18-82	14 N.J.R. 82(a)
<b>INSURANCE-TITLE 11</b>			
11:2-17.7	Claims settlement practices	9-7-82	14 N.J.R. 966(a)
11:12-18	Readable policies	9-7-82	14 N.J.R. 967(a)
11:13	Commercial lines insurance	9-20-82	14 N.J.R. 1045(a)
<b>LABOR AND INDUSTRY-TITLE 12</b>			
12:15-1.3	1983 maximum weekly unemployment and temporary disability benefits	9-7-82	14 N.J.R. 969(a)
12:15-1.4	1983 taxable wage base for unemployment contributions	9-7-82	14 N.J.R. 970(a)
12:15-1.5	1983 unemployment contribution rates for governments	9-7-82	14 N.J.R. 970(b)
12:235-1.5	1983 maximum workers' compensation rates	9-7-82	14 N.J.R. 971(a)
<b>LAW AND PUBLIC SAFETY-TITLE 13</b>			
13:21-8.10	Vision standards for motor vehicle drivers	7-6-82	14 N.J.R. 700(a)
13:27A	Price posting in barber shops	7-19-82	14 N.J.R. 479(a)
13:29-1.6	CPA qualifying requirements	7-19-82	14 N.J.R. 749(b)
13:29-3.1-3.9, 3.12-3.18	Board of Accountancy: Professional misconduct	8-16-82	14 N.J.R. 985(a)
13:30-6.2	Dental hygienists and hygiene school directorships	1-18-82	14 N.J.R. 89(a)
13:30-6.3	Oral hygiene schools and advisory council provision	2-1-82	14 N.J.R. 135(a)
13:30-6.6	Repeal dormitory requirement for oral hygiene schools	2-1-82	14 N.J.R. 136(a)
13:30-6.9(a)	Oral hygiene schools: Admissions	12-7-81	13 N.J.R. 880(a)
13:30-8.7	Dental personnel law test requirement	1-18-82	14 N.J.R. 89(b)
13:32-1.8	Pressure seal on plumbing permit applications	7-19-82	14 N.J.R. 759(a)
13:33-1.1-1.4, 1.7 1.11-1.13, 1.19, 1.25, 1.39, 1.42	Licensure of ophthalmic dispensers and technicians	6-7-82	14 N.J.R. 545(a)
13:33-1.5, 1.6, 1.9 1.10, 1.15-1.18, 1.34	Repeal ophthalmic licensure rules	6-7-82	14 N.J.R. 545(a)
13:33-1.38	Minimum standards for eyeglass dispensing	10-4-82	14 N.J.R. 1085(a)
13:35-9	Certified Nurse Midwife and lay midwife practice	6-21-82	14 N.J.R. 632(b)
13:35-11	In-State clinical training by foreign medical schools	6-7-82	14 N.J.R. 548(a)
13:35-12	Prolonged prescribing of Schedule II narcotics	11-16-81	13 N.J.R. 815(a)
13:36-3.4	Mortuary science examination subjects	8-16-82	14 N.J.R. 897(a)
13:36-5.12	Mortuary advertising requirements	8-16-82	14 N.J.R. 898(a)
13:37-9.2	Practical nursing licensure by examination	7-6-82	14 N.J.R. 701(a)
13:39-8.14, 9.14	Pharmacist-in-charge; in-store pharmacies	8-16-82	14 N.J.R. 898(b)
13:37-12.1	Board of Nursing: Licensure fees	6-21-82	14 N.J.R. 635(a)
13:39-6.4, 6.5, 6.8, 9.13	Computerized recordkeeping in pharmacy practice	2-1-82	14 N.J.R. 136(b)
13:44A-7.1	Uniform rule petitions to professional boards	10-8-81	13 N.J.R. 664(b)
13:44A-8	Licensing boards: Uniform testing process	11-16-81	13 N.J.R. 816(a)
13:44A-9	Licensing boards: Uniform complaint procedures	11-16-81	13 N.J.R. 817(a)
13:45A-18.1-18.3	Kosher food representation rules	10-8-81	13 N.J.R. 666(a)
13:45A-19.1, 19.2	Consumer notification on home appointments	10-8-81	13 N.J.R. 679(a)
13:46-1.1	Boxing and wrestling programs: Definitions	7-19-82	14 N.J.R. 751(b)
13:46-1.2-1.4	Weights and classes: Recodify as subchapter 1A	7-19-82	14 N.J.R. 751(b)
13:46-4	Boxing and wrestling programs: Licenses and permits	7-19-82	14 N.J.R. 751(b)
13:46-15.5, 15.6, 15.17, 15.18	Complimentary tickets for boxing and events wrestling	9-7-82	14 N.J.R. 971(b)
13:47A-1.1, 1.8	Securities industry: Nonduplication of fingerprinting	6-7-82	14 N.J.R. 550(a)
13:70-3.35	Thoroughbred racing rules	1-18-82	14 N.J.R. 91(a)
<b>PUBLIC UTILITIES-TITLE 14</b>			
7:26-6	Interdistrict and intradistrict solid waste flow	9-20-82	14 N.J.R. 1027(b)
14:3-7.11A	Uniform budgeting plan for residential customers	9-20-82	14 N.J.R. 1048(a)
14:3-11	New major gas and electric facilities	3-1-82	14 N.J.R. 228(a)
14:9-6	Water and sewer utilities: Depreciation on contributed property	11-2-81	13 N.J.R. 744(a)
14:17-18	CATV rate regulation	5-3-82	14 N.J.R. 422(b)

<b>N.J.A.C. CITATION</b>		<b>PROPOSAL DATE</b>	<b>PROPOSAL NOTICE (N.J.R. CITATION)</b>
14:18-3.9	CATV refunds for service interruptions	9-7-82	14 N.J.R. 972(a)
<b>ENERGY-TITLE 14A</b>			
14A:12-1	Computing energy cost savings in shared-savings contracts	8-2-82	14 N.J.R. 820(a)
<b>TRANSPORTATION-TITLE 16</b>			
16:28A-1.2	Parking on Route 1 and 9 in Newark	9-20-82	14 N.J.R. 1049(a)
16:30-2.6	Old Yorke Road and Rising Sun Square Road, Bordentown (with Emergency Adoption)	9-7-82	14 N.J.R. 990(a)
16:31-1.19	Turns on Route 33 in Mercer County	9-7-82	14 N.J.R. 973(a)
16:53-2	Autobus specifications	11-16-81	13 N.J.R. 834(a)
16:74	Regular route bus service: Destructive competition claims	4-5-82	14 N.J.R. 326(b)
<b>TREASURY-GENERAL-TITLE 17</b>			
17:12-5.1	Subscription fee for State contract information	10-4-82	14 N.J.R. 1085(b)
17:16-5.1-5.6	State Investment Council funds	4-5-82	14 N.J.R. 329(b)
17:16-43.1, 43.2	Mortgage-backed securities	6-21-82	14 N.J.R. 652(a)
17:28	Charitable contributions and State payroll deductions	1-18-82	14 N.J.R. 109(a)
<b>TREASURY-TAXATION-TITLE 18</b>			
18:7-3.5	Corporation Business Tax and short table	8-2-82	14 N.J.R. 826(b)
18:24-4.6, 5.16	Sales tax and capital improvements	10-4-82	14 N.J.R. 1086(a)
18:35-1.15	Gross income tax withholding exclusion	11-16-82	13 N.J.R. 839(b)
18:35-2.3-2.5, 2.7	Gross income tax refunds and debt setoff	7-6-82	14 N.J.R. 705(b)
<b>TITLE 19 SUBTITLES A-L-OTHER AGENCIES (Except Casino Control Commission)</b>			
19:1-1.6	Debarment and suspension from contracting	9-20-82	14 N.J.R. 1050(a)
19:4-4	Waterfront Recreation Zone: Permitted uses	7-6-82	14 N.J.R. 706(a)
19:9-1.9	Bus length on Turnpike	10-4-82	14 N.J.R. 1087(a)
19:9-2.1	Hearing officer in rejected bidder appeals	9-7-82	14 N.J.R. 974(a)
19:9-4.2	Fees for photographs and slides	9-7-82	14 N.J.R. 974(b)
19:17	Appeal Board on representation fees	8-16-82	14 N.J.R. 903(a)
19:75	Rules of operation: Atlantic County Transportation Authority	3-15-82	14 N.J.R. 272(a)
<b>TITLE 19 SUBTITLE K-CASINO CONTROL COMMISSION</b>			
19:45-1.11	Line of authority; reporting of violations	10-4-82	14 N.J.R. 1087(b)
19:45-1.36	Slot machine entry	9-20-82	14 N.J.R. 1052(a)
19:45-1.39	Resetting of progressive slot machines	9-20-82	14 N.J.R. 1053(a)
19:46-1.1, 1.6	Gaming chips and plaques	8-2-82	14 N.J.R. 828(a)
19:46-1.2	Gaming plaques	7-6-82	14 N.J.R. 708(a)
19:46-1.16, 1.18	Use of cards and dice	8-2-82	14 N.J.R. 829(a)
19:46-1.17	Use of cards in baccarat	7-19-82	14 N.J.R. 754(a)
19:46-1.19	Blackjack equipment	6-7-82	14 N.J.R. 559(b)
19:47-2.1	Exclusion of card counting in blackjack	5-17-82	14 N.J.R. 467(a)
19:47-2.1-2.7	Blackjack play and wagering (see 14 N.J.R. 841(b), 991(a))	6-7-82	14 N.J.R. 559(b)
19:47-2.2	Correction: Double shoe in blackjack		14 N.J.R. 832(a)
19:47-2.5	"Shuffle-at-will" in blackjack	5-17-82	14 N.J.R. 469(a)
19:47-2.8, 2.13, 2.23-2.26	Blackjack rules	8-16-82	14 N.J.R. 907(a)
19:47-2.9-2.12, 2.15, 2.16	Blackjack play and wagering (see 14 N.J.R. 841(b))	6-7-82	14 N.J.R. 559(b)
19:47-2.16-2.19	Card counting exclusion	5-17-82	14 N.J.R. 467(a)
19:47-2.20-2.22, 5.7	Blackjack play and wagering (see 14 N.J.R. 841(b))	6-7-82	14 N.J.R. 559(b)

The following rules were proposed in the September 10, 1981 New Jersey Register, but have not been timely adopted and therefore have expired pursuant to N.J.A.C. 1:30-4.2(c).

10:44A	Community residences for retarded	13 N.J.R. 574(a)
10:51-1.17, 1.18	Legend drug reimbursement options	13 N.J.R. 576(a)
10A:70-8	Certificate of Good Conduct	13 N.J.R. 596(b)
10A:71-1.5	Parole Board revisions	13 N.J.R. 597(b)
10A:71-9	Parole Board clemency rules	13 N.J.R. 598(b)
13:19-10.5	Reduction of driver point accumulation	13 N.J.R. 606(a)

# CONTENTS

(Continued From Front Cover)

Construction of wastewater treatment facilities .....	1155(b)
1982-83 Game Code changes .....	1158(a)
Senior citizen's oyster license .....	1158(b)
<b>HEALTH</b>	
Generic drug list changes .....	1159(a)
Generic drug list changes .....	1159(b)
Generic drug list changes .....	1160(a)
Generic drug list changes .....	1160(b)
<b>HUMAN SERVICES</b>	
Reporting chemotherapy injectable drugs .....	1161(a)
PAM: Legally responsible relatives .....	1161(b)
PAM: Extension of Medicaid benefits .....	1161(c)
ASH: Relatives as a resource .....	1161(d)
GAM: Eligibility of young people .....	1162(a)
GAM: Eligibility of refugee groups .....	1162(b)
Medicaid Only: Burial and funeral expenses .....	1162(c)
<b>INSURANCE</b>	
Correction: Real Estate Commission rules .....	1162(d)
<b>LAW AND PUBLIC SAFETY</b>	
Readopted: Motor vehicle inspection .....	1162(e)
Repealed: "Title only" motor vehicle certification ...	1163(a)
<b>STATE</b>	
Repeal rules on Register and Code .....	1163(b)
<b>TREASURY—GENERAL</b>	
Annual reports of salary changes .....	1163(c)
Pensioners' Group Health Insurance .....	1163(d)
Pension purchases and final payments .....	1163(e)
Division of Pensions administrative priorities .....	1164(a)
PERS: Contributory insurance rate .....	1164(b)
Teachers' Pension: Board meetings .....	1164(c)
Consolidated police and firemen's disability .....	1164(d)
Supplemental Annuity: Voluntary employee contributions .....	1164(e)
Health coverage and 10-month employees .....	1165(a)
Judicial Retirement System: Maternity leave .....	1165(b)
Judicial Retirement System: Disability .....	1165(c)
Cash Management Fund: Statement correction .....	1166(a)
State Employees Deferred Compensation Plan .....	1166(b)
<b>TREASURY—TAXATION</b>	
Cash discounts: Motor fuel sales .....	1166(c)
<b>OTHER AGENCIES</b>	
<b>HIGHWAY AUTHORITY</b>	
Off-premise outdoor advertising along Parkway .....	1166(d)
<b>CASINO CONTROL COMMISSION</b>	
Exclusion of persons: Hearings .....	1167(a)
<b>EMERGENCY ADOPTIONS</b>	
<b>HUMAN SERVICES</b>	
Public Assistance Manual: Uniformed service absence; rounding .....	1168(a)
Assistance Standards Handbook: Rounding; prorating; military service absence .....	1169(a)
Food Stamp Program: Utility allowance; coupon allotment; rounding .....	1170(a)
<b>MISCELLANEOUS NOTICES</b>	
<b>ENVIRONMENTAL PROTECTION</b>	
Water Supply Bond Loans: Application closing date ..	1172(a)
Lower Delaware Water Quality Management .....	1172(b)
Petition for rulemaking: Water supply extension .....	1172(c)
Certification of draft NPDES permits .....	1173(a)
<b>LAW AND PUBLIC SAFETY</b>	
Common carrier applicants .....	1173(b)
<b>OTHER AGENCIES</b>	
<b>CASINO CONTROL COMMISSION</b>	
Petition for rulemaking: Entertainment within casino room .....	1173(c)

INDEX OF PROPOSED RULES ..... 1175

## Filing Deadlines

### November 1 issue:

Proposals ..... October 7

Adoptions ..... October 18

### November 15 issue:

Proposals ..... October 21

Adoptions ..... October 28

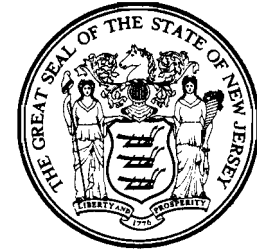

## OFFICE OF ADMINISTRATIVE LAW

### PUBLICATIONS

#### **NEW JERSEY ADMINISTRATIVE REPORTS**

The full text of selected administrative law decisions and the final State agency determinations. Fully indexed.

#### **NEW JERSEY REGISTER**

The State's official rules reporter and interim supplement to the New Jersey Administrative Code. Issued twice monthly.

#### **NEW JERSEY ADMINISTRATIVE CODE**

A loose-leaf compilation of rules promulgated by the State's executive agencies. Supplemented.

#### **NEW JERSEY CIVIL SERVICE RULEBOOK**

The full text of rules governing the State's public employment system. Includes Local Service rules.

For further information, write to:

Administrative Publications  
88 East State Street  
CN 301  
Trenton, NJ 08625

Or call: (609) 292-6060