

**Minutes of the Regular Meeting of The  
New Jersey Maritime Pilot and Docking Pilot Commission  
October 15, 2024**

Audit Committee Meeting

The Audit Committee met with the accounting firm of Kayode Agunbiade, LLC to go over the findings of the Commissions FY24 audit. The auditor reported that the financial statements present fairly, in all material respects, the financial position of the New Jersey Maritime Pilot and Docking Pilot Commission for the year ended June 30, 2024, and the changes in its net assets and its cash flows for the year are in accordance with the accounting principles generally accepted in the United States.

Regular Meeting

A hybrid meeting of the New Jersey Maritime Pilot and Docking Pilot Commission was held on Tuesday, October 15, 2024.

Commissioner Dacey called the meeting to order at 10:05am

Open Public Meeting Statement

Ms. Stuckey read the Open Public Meetings Act Statement into the record.

Roll Call

Commissioner Timothy J. Dacey (via ZOOM); Commissioner Nicholas Fixmer (via ZOOM); Commissioner Bjoern Kils (via ZOOM); Commissioner Dana Martinotti (via ZOOM); Commissioner Brendan Roberts (absent); Commissioner Charles Wowkanech (present).

Mrs. Stuckey extended the apologies of Commissioner Brendan Roberts for not being able to attend the meeting.

Also included in the meeting were: Andre Stuckey, Executive Director, (present); Al Hawkins (Administrative Assistant (present); Dorian Smith, Senior Counsel, Authorities Unit (present) Captain Timothy Ferrie, President, Sandy Hook Pilots Association (via ZOOM); Captain Jon Miller, President, Metro Pilots Association (via ZOOM); Captain Adam Richardson, President, Interport Pilots Association (present).

The following Pilots and Apprentices were in attendance via ZOOM for their annual reviews: Captain Daniel Boylan; Captain Scott Esposito; Captain Paul Torres; Captain Kenneth Barsch; Captain Eric Lavin; Captain James P. Britton; Captain Peter Rooss and Apprentice Luke Germanakos.

Approval of the September 17, 2024, Meeting Minutes

A motion was made by Commissioner Kils; seconded by Commissioner Fixmer to approve the September 17, 2024, meeting minutes.

The motion passed unanimously.

Resolution #24-26 to Approve the October 2024, Treasurers Report

A motion was made by Commissioner Fixmer; seconded by Commissioner Martinotti to approve the October 2024 Treasurers Report.

The motion passed unanimously.

Executive Directors Report

Ms. Stuckey announced that Captain Pinto was called to work and will not be in attendance. Captain Miller will report on behalf of Harbor and Metro Pilots Associations.

Ms. Stuckey also commended the Pilots on the way they handled the port worker strike. They worked to ensure that all container and car carrier vessels were out of the port before the strike began. Once the strike was over, they again worked diligently to catch up so there was never a large back log.

A. A copy of the pilot log was sent to the Commissioners.

B. Ms. Stuckey gave the Commissioners an update on the move. New Jersey Transit has already begun to move some of their offices to the new location. She reported that the Commission's offices are scheduled to be moved on December 20, 2024. She has been notified that there will be no designated parking for employees at the new location and she was advised to contact the parking garage in the new location to set up monthly parking. The parking at the new location ranges from \$380 to \$400 per month. The Commission currently pays \$190 per month for parking at Edison Parkfast. Ms. Stuckey recommended that she continue

to park at Edison Parkfast, and she would be able to validate parking for the Commissioners that will be billed at the end of each month. After conversation, the Commission agreed with the recommended course of action.

- C. The Commissioners were sent a copy of a revised Pilot and Apprentice appearance schedule. The schedule is color coded by Association. The appearances were staggered to ensure that each month there would be no more than 6-7 pilots in attendance. The schedule has been electronically sent to all Pilots and Apprentices asking them to get back to the Commissions office with any schedule conflicts. Once the schedule is finalized, Ms. Stuckey will send the schedule via mail with a memo stating that there will be no changes to the schedule unless there is an emergency. The memo will also note that pilots are required to ensure that their files are updated by forwarding information on upgrades, license renewals, physicals, etc. upon receipt.
- D. The New York Commission hired a replacement for Andrew Garger who will retire at the end of the year. The name of his replacement is Captain Kyle Weist. He is retiring from the Coast Guard and will begin working with Mr. Garger part-time beginning November 1<sup>st</sup>. He will convert to full-time on December 1<sup>st</sup>. Mr. Garger will stay on board until December 30<sup>th</sup>. Ms. Stuckey plans to travel to the New York Commission to meet with Captain Weist in early December. The New York Commission has also suggested that the two Commissions plan to meet semi-annually to discuss issues that involve both states.
- E. Ms. Stuckey attended the September 25, 2024, virtual Harbor Ops meeting. It was the last meeting of 2024. The main topic of discussion was how to prepare for the pending strike. Ms. Stuckey reported that the meetings were established to provide a forum for port stakeholders to discuss and come up with solutions for problems dealing with port safety, security and economic development. A large portion of the meetings have recently been taken over by recreational boaters. Ms. Stuckey reported her annoyance at a discussion with a recreational boater stating that their vessel was capsized by a passenger vessel that lasted 40 minutes until they were told to continue the discussion offline. Commissioner Kils attended the meeting and stated his agreement with Ms. Stuckey.

- F. The Coast Guard scheduled a Marine Transportation System Kick-off meeting that was rescheduled because of Hurricane Milton. Ms. Stuckey also expressed how she was impressed with Captain Andrechik. When Captain Andrechik met with the Commission, he stated his intent to keep the Commission involved and updated on initiatives in the port and he has held to his word.
- G. Commander Villafane has been named the Acting Vessel Traffic Service Director while maintaining her role as Waterways Management Chief. Mr. Hitchens departure was not expected, and it may take the Coast Guard some time to find a suitable replacement.
- H. Ms. Stuckey reminded the Commission that they authorized her to send a letter in support of the Hudson River Anchorages. The letter was drafted and reviewed by counsel before it was sent. The Commissioners were provided with a copy of the letter.
- I. Ms. Stuckey thanked Commissioner Fixmer for asking her to attend the Union County Job Fair. She stated that she met a candidate who is a retired Navy veteran and served as a helmsman during his tour. She was able to connect him with the Docking Pilot presidents which could potentially lead to a career on a tug.
- J. Trenz, the company that developed the Pilot Guard program wants to set up a demonstration with the pilots before its official launch. Ms. Stuckey is hoping to be able to set up the demonstration for mid-November. She advised the Commissioners to let her know if they wanted to participate in the demonstration. Ms. Stuckey has been informed that they currently have 1500 pilots nationally that are planning to utilize the program.
- K. Ms. Stuckey informed the Commission that the meetings with the Newark Board of Education and Kean college are ongoing. The next step in the process is to have a ZOOM Q&A forum with a representative from each of the Pilot Associations and the Board of Directors at Kean to get information on the type of maritime programs they should be offering. They are hoping to have a maritime component added to their curriculum by January 2026.
- L. Ms. Stuckey gave the Commissioners an update on upcoming events within the industry. The Liberty Nautical Education

dinner will be on October 17<sup>th</sup>. She, Commissioner Kils and Commissioner Dacey will attend. The Newark Board of Education will hold its partner meeting on October 24<sup>th</sup>. Ms. Stuckey plans to attend the event. The annual CONNIE Awards will take place on December 9<sup>th</sup>. Ms. Stuckey plans to attend the event. She advised that any Commissioner interested in attending any of these events to contact her and she will make the arrangements.

M. Ms. Stuckey reported that there were no staff vacations planned.

N. Ms. Stuckey sent the Commission articles of interest that she encouraged them to read at their leisure.

#### Committee Reports

- A. Docking Pilot Apprentice Selection Committee: The Committee received a total of 8 applications. The Committee met on October 10<sup>th</sup> to review the applications and select those to interview. A decision was made to interview all applicants. The interviews will take place in person at the Commissions office. Interview dates were set for October 29<sup>th</sup> and December 5<sup>th</sup> other dates may need to be added to accommodate the working schedules of the pilots and applicants. The Committee is hopeful that they will have a list with recommendations before the Commission at its December 17<sup>th</sup> meeting.
- B. Capital Surcharge Committee: The Committee met on September 26<sup>th</sup> to review the plans to replace the Motorboat Sandy Hook with the Motorboat Romer. The Sandy Hook is being replaced because the hull design makes it ride poorly in heavy seas which ultimately reduced its role to back up launch in the summer. The Committee was presented with an analysis on the suitability of the Romer vs. the Sandy Hook. They were also presented with a rate history of the surcharge since its inception in 1999. Ms. Stuckey pointed out that over the years the surcharge was adjusted to suit the current needs of the Association. The ceiling for the surcharge is 300% and the current rate is set at 190%. The accountant reported that the current rate may be enough to comfortably fund the rebuild, however, Commissioner Roberts suggested that the surcharge should be raised by at least 5% to provide breathing room. The motion was put to a vote and the

Committee voted unanimously to raise the surcharge from 190% to 195%.

Public Comment

Report from Captain Timothy Ferrie, President, New Jersey Sandy Hook Pilots Association:

Captain Ferrie congratulated Captains Paul Torres, Scott Britton, James P. Britton, Luke Carrick and Peter Rooss on their upgrades. He stated that each pilot has been doing an excellent job and each promotion is well deserved.

Captain Ferrie also thanks Captain James P. Britton on his work in replacing the motorboat Sandy Hook with the motorboat Romer.

Captain Ferrie echoed Ms. Stuckey's comments on how well the Pilots, the Coast Guard and the Port Authority handled the ILA strike. The plan that was set in place was like the one used when the port is shut down. The only difference was all the ships were out of the port before the strike, so they only had to worry about bringing vessels in. The operations went off without any problems.

Captain Ferrie participated in a panel discussion with Captain Jon Andrechik and BethAnne Rooney. The discussion was sponsored by Seward and Kissel in New York. The topic of the discussion was "A Bridge Over Troubled Waters". Different scenarios were discussed on how the port would handle a bridge strike. The panel approached the discussion proactively. They spoke about the cooperation between the Pilots, the Coast Guard and the Port Authority. They also pointed out that the port has a strong Harbor Operations Committee that works together on all issues within the port. Captain Ferrie pointed out that the pilots continue to do simulation exercises as the vessels continue to get larger. The panel stated that it is their belief that the port is in good position to prevent and handle any mishaps.

Captain Ferrie reported that the crane has arrived. He thanked Captain Jon Miller on all the hard work he did in coordinating the transit into the port. He stated that it was great to be able to work with such a professional in bringing the crane in safely.

Report from Captain Jon Miller, President, Metro Pilots Association:

Captain Miller reported that he received a phone call regarding the Zen Hua. The vessel is sitting in Graves End Bay waiting to be brought into the port. The plan is to lower the booms on Thursday for a Friday morning Transit. A vessel of this height is historic and has never entered the port so there are a lot of agencies involved in the transit. The MTA is heavily involved and plans to close traffic on the Verrazano Bridge. The transit can only be completed at night for safety reasons.

Commissioner Dacey inquired about the time the vessel will transit under the bridge. Captain Miller stated that it is scheduled to begin at 0300 and should clear the bridge by 0330.

Ms. Stuckey inquired whether herself and any of the Commissioners would be allowed to ride on one of the tugs. Captain Miller stated that he would have to get back to her. It is an overwhelming and complicated situation because of all the agencies involved.

Captain Miller reported that another crane ship is on the way for APM, but it is less of a severe situation.

Captain Miller gave a report on the joint simulation exercises in Baltimore for the new berth opening at Port Liberty in Bayonne. The Sandy Hook Pilot presidents, all the Docking Pilots and terminal representatives were in attendance. The exercises were very successful. The Docking Pilots enjoyed working together and stated that joint training should be done more often. The training focused on team building and bridge resource management. The Pilots stated that being on a vessel communicating via radio or passing one another in the channel is one thing, however, to be able to sit down, talk about the ships, be in the simulator together and share information was excellent. The exercises revealed that docking the large cruise ships at the berth will be a good use of the space, however there will be heavy restrictions.

During the exercises the pilots also simulated the proposed 55-foot channel and how it would handle the large vessels. The exercises worked out great.

Captain Miller spoke to Ms. Stuckey's comments regarding Captain Villafane and reported that she is doing well and has already developed a good working relationship with the Pilots.

Report from Captain Adam Richardson, President, Interport Pilots Association:

Captain Richardson reported that Interport had a busy summer, and they are looking forward to a quieter fall season.

Resolution # 24-26 to Approve the FY24 Audit

Commissioner Dacey reported that the Audit Committee met with the accounting firm of Kayode Agunbiade, LLC prior to the board meeting to discuss the findings of the FY24 Audit. The audit was found to be an unqualified audit, and the Commissions finances are in good shape. No deficiencies were found. The cash balances were good, and the Commission finished the fiscal year with total current liabilities and unrestricted net assets of about \$157,000. The Commission has successfully over the years decreased the amount on account with the state to a very manageable amount of about \$30,000. The Commissions fiscal management is done well, and Andre has done a great job of figuring out what the budget should be and ensuring the Commission stays in the confines of the budget.

A motion was made by Commissioner Wonkiness; seconded by Commissioner Kils to pass Resolution #24-26 approving the FY24 Audit.

The motion passed unanimously.

Commissioner Dacey thanked Commissioner Wowkanech for filling in for Commissioner Roberts at the Audit Committee meeting.

Resolution #24-27 to Approve the Maritime Pilot Apprentice Selection List

Ms. Stuckey reported that she believes the Committee put together a strong list. She sent the Commissioners a summary of each applicant on the list, and advised if any Commissioner wanted to view the electronic applications to let her know and she will make the necessary arrangements. Ms. Stuckey enjoyed working with the other committee members and thanked them for their hard work during the process.

A motion was made by Commissioner Kils; seconded by Commissioner Wowkanech to pass Resolution #24-27 to Approve the Maritime Pilot Apprentice Selection List.

The motion passed unanimously.

Commissioner Dacey expressed his gratitude to the Sandy Hook Pilots, Ms. Stuckey and the New York Commission representative for their efforts in putting together a list of well qualified candidates.

Resolution #24-28 to Approve the Upgrade of Captain Scott Britton to a Pilot of the Fourth Grade

Ms. Stuckey reported that the Commission approved the amended advancement schedule of the Sandy Hook Pilots which allowed for the first four Deputy Pilot grades to be done semi-annually. The pilot would not have to appear for the semi-annual upgrade and the performance of the Pilot would be reviewed by the Operations Manager. He would then provide the Commission with a recommendation on whether the pilot is qualified for the upgrade. There are resolutions on the agenda to approve the six-month upgrades for Captains James Britton and Luke Carrick.

A motion was made by Commissioner Wowkanech; seconded by Commissioner Martinotti to pass Resolution #24-28 to approve the Upgrade of Captain Scott T. Britton to a Pilot of the Fourth Grade.

The motion passed unanimously.

Resolution #24-29 to Approve the Upgrade of Captain Luke Carrick to a Pilot of the Sixth Grade

A motion was made by Commissioner Kils; seconded by Commissioner Fixmer to pass Resolution #24-29 to approve the Upgrade of Captain Luke Carrick to a Pilot of the Sixth Grade.

The motion passed unanimously.

Executive Session

Commissioner Dacey reported that the Commission will enter Executive Session for the Annual Review of Pilots and Apprentices, Legal and Personnel Discussions. Upon its return

to Public Session the Commission will take action to upgrade three Pilots and a Personnel matter.

Ms. Stuckey read the following statement into the record:

Whereas, the Open Public Meetings Act provides that a public body such as the New Jersey Maritime Pilot and Docking Pilot Commission may meet in closed session to discuss legal and personnel matters, and

Whereas, the Commission desires to meet in closed session to discuss such matters.

Now therefore, be it resolved that the Commission shall at this time meet in closed session to discuss such matters, the substance of the closed session would be disclosed publicly only if it would not warrant an invasion of privacy or constitute a breach of the attorney client privilege.

A motion was made by Commissioner Wowkanech; seconded by Commissioner Martinotti that the Commission enter Executive Session.

The motion passed unanimously.

The Commission entered Executive Session at 10:38am.

#### Return to Public Session

A motion was made by Commissioner Wowkanech; seconded by Commissioner Fixmer that the Commission return to Public Session.

The motion passed unanimously.

The Commission returned to public session at 11:10am.

#### Resolution #24-30 to Approve the Upgrade of Captain Paul Torres to a Pilot of the Second Grade

A motion was made by Commissioner Wowkanech; seconded by Commissioner Kils to pass Resolution #24-30 to Approve the Upgrade of Captain Paul Torres to a Pilot of the Second Grade.

The motion passed unanimously.

#### Resolution #24-31 to Approve the Upgrade of Captain James P. Britton to a Pilot of the Third Grade

A motion was made by Commissioner Wowkanech; seconded by Commissioner Fixmer to pass Resolution #24-31 to Approve the Upgrade of Captain James P. Britton to a Pilot of the Third Grade.

The motion passed unanimously.

Resolution #24-32 to Approve the Upgrade of Captain Peter Rooss, Jr. to a Pilot of the Sixth Grade

A motion was made by Commissioner Martinotti; seconded by Commissioner Wowkanech to pass Resolution #24-32 to Approve the Upgrade of Captain Peter Rooss, Jr. to a Pilot of the Sixth Grade.

The motion passed unanimously.

Personnel Action

A motion was made by Commissioner Wowkanech; seconded by Commissioner Kils to approve a personnel action taken by the Commission.

The motion passed unanimously.

Adjournment

A motion was made by Commissioner Wowkanech; seconded by Commissioner Kils that the Meeting be adjourned.

The motion passed unanimously.

The meeting was adjourned at 11:14am.

THE NEW JERSEY MARITIME PILOT AND DOCKING PILOT COMMISSION  
2025 PILOT ANNUAL APPEARANCE SCHEDULE

**January 21, 2025**

Jesse Malmgren  
Stephen Richter  
Karl Gadow  
Karen Nola  
Timothy Ferrie  
Paul Klein

**February 18, 2025**

Elizabeth Miller  
Ronald Perry  
Robert Flannery  
Charles Fannon  
Timothy Nilsen  
Sheldon Davis

**March 18, 2025**

Andrew Baeird  
Richard Wood  
Jonathan Miller  
Salvador Rivas  
\*\*Benjamin White  
Michael Vanek

**April 15, 2025**

Christopher Baker  
Adam Richardson  
Joseph Bosch  
Joseph Paulis  
Scott Britton  
Luke Carrick

**May 20, 2025**

Kirk Pinto  
William O'Neill

Thomas Ferrie  
Brian Paiva  
William Baeszler  
Michael Chambers  
\*\*Zachery Dietrich

**June 17, 2025**

Joseph Casaletto  
Donald Occhipinti  
Daniel Zorovich  
Leonard Evans  
Brendan Foley  
Nils Tribus  
Jon Flanders

**July 15, 2025**

\*\*Robert Oldmixon  
Harold Cavagnaro  
Graham Mergenthaler  
\*\*Matthew Keenan  
Randall Murphy  
Frank DiMatteo  
\*\*Steven Altini

**August 19, 2025**

Kevin Walsh  
\*\*James Jorgenson  
Mark Hershey  
Stephen Doherty  
Mark Wanderer  
William Speiser  
Ryan Pakalik

**September 16, 2025**

James R. Britton  
David Graves

Nicholas Pitch  
Craig Tomalo  
Alexander Woodworth  
Kevin Metkiff

**October 21, 2025**

Daniel Boylan  
Paul Torres  
James P. Britton  
Scott Esposito  
Kenneth Barsch  
Eric Lavin

**November 18, 2025**

Frank Reinbold  
Sean Meade  
Fred Dashkoff  
\*\*Luke Germanakos  
\*\*Kyle Sammis  
Peter Rooss

**December 16, 2025**

William Blake  
Coleen Quinn  
Adam Graves  
Russell Henchmann  
Douglas Mattson  
William Clifford

\*\* = Apprentice; Blue = Sandy Hook; Green = Metro; Purple – Interport; Red = Harbor

RESOLUTION TO APPROVE THE MONTHLY TREASURERS REPORT

WHEREAS, Pursuant to N.J.S.A. 12:8-4 pilotage revenue received by the Commission shall be used to compensate the Commissioners, their expenses, rent, utilities, supplies, employee salaries, benefits and any miscellaneous expenses that may be incurred, and

WHEREAS, at the direction of the Treasurer, staff prepares a monthly report listing all expenses incurred by the Commission, and

WHEREAS, the Treasurer has reviewed the monthly report and recommends that the Commission approve the report for the month of October 2024.

NOW THEREFORE BE IT RESOLVED BY the New Jersey Maritime Pilot and Docking Pilot Commission that the Treasurers report for the month of October 2024 is hereby approved and staff is directed to make the necessary payments to its creditors.

# The New Jersey Maritime Pilot & Docking Pilot Commission

One Penn Plaza East \* 9<sup>th</sup> Floor \* Newark, NJ 07105

## Treasurers Report October 2024

### E.D. Travel & Expense

9/20 – Port Newark; 9/28 – Plainfield; 10/11 – Port Newark \$45.90

### Miscellaneous Expenses:

N.J. Transit (October rent) \$2,588.00

T-Mobile (phone & tablets) \$130.79

Document Solutions (copy machine) \$87.14

Document Solutions (copy count overage) \$66.86

Bank of America purchasing card (supplies, notary renewal; Mtg, LINE dinner) \$578.18

Bank of America travel card (parking; EZ Pass) \$482.00

Kayode Agunbiade & Co. (FY24 Audit) \$7,000.00

Office Depot Business Solutions (supplies) \$184.09

WorkBoat Magazine (Docking Pilot open ad) \$2,103.75

Grand Total ..... **\$13,266.71**

## Pilot Activity August 2024

Vessels Piloted inbound: 196                      Vessels Piloted outbound: 205

**Maritime Pilot Fees to date: \$290,134.43**

**Docking Pilot Fees to date: \$9,850.88**

Certified to have been checked, and believed to be accurate:

*Charles Wowkanek, Treasurer*

New Jersey Maritime Pilot and Docking Pilot Commission

10/7/2024 10:34 AM

Register: Checking Account

From 10/01/2024 through 10/30/2024

Sorted by: Date, Type, Number/Ref

Date	Number	Payee	Account	Memo	Payment	C	Deposit	Balance
10/04/2024	3407	Andre M. Stuckey	Travel	travel expense r...	45.90			133,832.00
10/04/2024	3408	New Jersey Transit	Rent Expense	rent	2,588.00			131,244.00
10/04/2024	3409	TMobile	Telephone Expense	telephone	130.79			131,113.21
10/04/2024	3410	Document Solutions	Office Fixture/Equipm...	copier	87.14			131,026.07
10/04/2024	3411	Document Solutions	Office Fixture/Equipm...	copy count	66.86			130,959.21
10/04/2024	3412	Bank of America	-split-	various	578.18			130,381.03
10/04/2024	3413	Bank of America	-split-	various	482.00			129,899.03
10/04/2024	3414	Kayode Agunbiade ...	Audit Fees	FY4 Audit	7,000.00			122,899.03
10/04/2024	3415	Office Depot	Office Supplies	VOID: supplies...		X		122,899.03
10/04/2024	3416	Work Boat Magazine	newspaper/Magazine A...	Docking Pilot Ad	2,103.75			120,795.28
10/04/2024	12	Office Depot	Office Supplies	For CHK 3415 ...	31.15	X		120,764.13
10/07/2024	3417	Office Depot	Office Supplies	supplies	184.09			120,580.04
10/07/2024	12R	Office Depot	Office Supplies	Reverse of GJE...		X	31.15	120,611.19

**Operating Budget FY 2025**  
**New Jersey Martime Pilot and Docking Pilot Commission**  
**July 1 2025 - June 30, 2026**

**EXPENSES**

Line Item	FY25 Approved	FY 25 YTD	Net Difference
Rent	\$ 40,000.00	\$ 10,352.00	\$ 29,648.00
Postage	\$ 250.00	\$ -	\$ 250.00
Supplies	\$ 3,000.00	\$ 418.93	\$ 2,581.07
Printing	\$ 1,500.00	\$ -	\$ 1,500.00
Meetings	\$ 3,000.00	\$ 248.34	\$ 2,751.66
Telephone	\$ 1,700.00	\$ 392.41	\$ 1,307.59
Newspaper/Magazine Announcements	\$ 3,000.00	\$ 2,103.75	\$ 896.25
Office Fixtures/Equipment	\$ 3,500.00	\$ 604.63	\$ 2,895.37
Awards/Plaques/Certificates	\$ 250.00	\$ -	\$ 250.00
Audit Fees	\$ 5,500.00	\$ 7,000.00	\$ (1,500.00)
Id/Badges/Wallets	\$ 500.00	\$ -	\$ 500.00
Subscriptions	\$ 1,000.00	\$ 320.37	\$ 679.63
Annual Memberships	\$ 3,000.00	\$ -	\$ 3,000.00
Travel	\$ 2,500.00	\$ 908.37	\$ 1,591.63
Conference/Seminar/Special Events	\$ 4,500.00	\$ 600.00	\$ 3,900.00
Occurrence Investigation	\$ 8,000.00	\$ 900.00	\$ 7,100.00
Continuing Education	\$ 2,500.00	\$ -	\$ 2,500.00
Annual Parking	\$ 5,000.00	\$ 1,522.00	\$ 3,478.00
Incidental Expenses	\$ 2,000.00	\$ 15.00	\$ 1,985.00
Office of Administrative Law	\$ 6,000.00	\$ -	\$ 6,000.00
Pilot Training	\$ 10,000.00	\$ -	\$ 10,000.00
Staff Salaries	\$ 210,000.00	\$ 67,131.88	\$ 142,868.12
Fringe Benefits	\$ 125,000.00	\$ 24,128.60	\$ 100,871.40
Commissioner Salaries	\$ 168,000.00	\$ 56,000.00	\$ 112,000.00
Legislative Cruise	\$ 5,000.00	\$ -	\$ 5,000.00
Relocation Expenses	\$ 40,000.00	\$ -	\$ -
<b>TOTAL EXPENSES</b>	<b>\$ 654,700.00</b>	<b>\$ 172,646.28</b>	<b>\$ 654,700.00</b>

**INCOME**

Line Item	FY25 Approved	FY 25 YTD	Net Difference
Sandy Hook Fees	\$ 650,000.00	\$ 290,134.43	\$ (359,865.57)
Docking Pilot Fees	\$ 8,000.00	\$ 9,850.88	\$ 1,850.88
Miscellaneous Income	\$ -	\$ -	\$ 133.37
Prior Year Surplus*	\$ 150,000.00	\$ 44,546.16	\$ 44,546.16
Release of Funds in Reserve	-	-	\$ -
<b>TOTAL INCOME</b>	<b>\$ 808,000.00</b>	<b>\$ 344,531.47</b>	<b>\$ (463,468.53)</b>

RESOLUTION TO APPROVE THE FY24 AUDIT

WHEREAS, the New Jersey Maritime Pilot and Docking Pilot Commission (Commission) is a state agency which spends public funds, and

WHEREAS, the Commission voted at its August 20, 2024 regular meeting to hire Kayode Agunbiade & Co. (auditor) to perform an audit of the Commission's financial records for the fiscal year ending June 30, 2024, and

WHEREAS, the Commission met with the auditor and reviewed the findings of the FY24 Audit, and

WHEREAS the Commission was satisfied with the audit and its findings.

NOW THEREFORE BE IT RESOLVED by the New Jersey Maritime Pilot and Docking Pilot Commission that the attached FY24 Audit report received from Kayode Agunbiade & Co. is hereby accepted by the Commission.

BE IT FURTHER RESOLVED that the Commission's staff is directed to forward the report to the Office of the State Comptroller and publish it on the Commission's website.

**The New Jersey Maritime Pilot and  
Docking Pilot Commission**

**Financial Statements  
For the year ended June 30, 2024 and 2023**

**The New Jersey Maritime Pilot and Docking Pilot Commission**

**Financial Statements**

**For the year ended June 30, 2024 and 2023**

**Table of Contents**

	Page
Independent Auditor's Report	1
Statements of Assets Liabilities and Net Assets	4
Statements of Revenue, Expenses and Changes in Net Assets	5
Statements of Cash Flows	6
Notes to Financial Statements	7



# KAYODE AGUNBIADE & Co.

Certified Public Accountants

Business Consultants



134 EVERGREEN PLACE (8th Floor)  
EAST ORANGE, NEW JERSEY 07018  
Tel.: (973) 676-9851/52  
Fax.: (973) 676-6739

## INDEPENDENT AUDITOR'S REPORT

Board of Commissioners  
The New Jersey Maritime Pilot and Docking Pilot Commission  
Newark, New Jersey

### Opinion

We have audited the accompanying financial statements of New Jersey Maritime Pilot and Docking Pilot Commission (the "Commission") which comprise the statement of financial position as of June 30, 2024 and 2023, and the related statements of activities and changes in net assets, cash flows for the years then ended, and the related notes to the financial statements.

In our opinion, the financial statements referred to above present fairly, in all material respects, the financial position of the New Jersey Maritime Pilot and Docking Pilot Commission for the year then ended as of June 30, 2024 and 2023, and the changes in its net assets and its cash flows for the year then ended in accordance with accounting principles generally accepted in the United States of America.

### Basis for Opinion

We conducted our audit in accordance with auditing standards generally accepted in the United States of America (GAAS). Our responsibilities under those standards are further described in the Auditor's Responsibilities for the Audit of the Financial Statements section of our report. We are required to be independent of the Commission, and to meet our other ethical responsibilities, in accordance with the relevant ethical requirements relating to our audit. We believe that the audit evidence we have obtained is sufficient and appropriate to provide a basis for our audit opinion.

### Responsibilities of Management for the Financial Statements

Management is responsible for the preparation and fair presentation of these financial statements in accordance with accounting principles generally accepted in the United States of America; this includes the design, implementation, and maintenance of internal control relevant to the preparation and fair presentation of financial statements that are free from material misstatement, whether due to fraud or error.

In preparing the financial statements, management is required to evaluate whether there are conditions or events, considered in the aggregate, that raise substantial doubt about The New

Jersey Maritime Pilot and Docking Pilot Commission's ability to continue as a going concern within one year after the date that the financial statements are available to be issued.

### **Auditor's Responsibilities for the Audit of the Financial Statements**

Our objectives are to obtain reasonable assurance about whether the financial statements as a whole are free from material misstatement, whether due to fraud or error, and to issue an auditor's report that includes our opinion. Reasonable assurance is a high level of assurance but is not an absolute assurance and therefore is not a guarantee that an audit conducted in accordance with generally accepted auditing standards will always detect a material misstatement when it exists. The risk of detecting a material misstatement resulting from fraud is higher than the one resulting from error, as fraud may involve collusion, forgery, intentional omissions, misrepresentations, or the override of internal control. Misstatements are considered material if there is a substantial likelihood that individually or in the aggregate, they would influence the judgement made by a reasonable user based on the financial statements.

In performing an audit in accordance with generally accepted auditing standards, we:

- Exercise professional judgement and maintain professional skepticism throughout the audit.
- Identify and access the risks of material misstatements of the financial statements, whether due to fraud or error, and design and perform audit procedures responsive to those risks. Such procedures include examining, on a test basis, evidence regarding the amounts and disclosures in the financial statements.
- Obtain an understanding of internal control relevant to the audit in order to design audit procedures that are appropriate in the circumstances, but not for the purpose of expressing an opinion on the effectiveness of The New Jersey Maritime Pilot and Docking Pilot Commission's internal control. Accordingly, no such opinion is expressed.
- Evaluate the appropriateness of accounting policies used and the reasonableness of significant accounting estimates made by management, as well as evaluate the overall presentation of the financial statements.
- Conclude whether, in our judgement, there are conditions or events, considered in the aggregate, that raise substantial doubt about The New Jersey Maritime Pilot and Docking Pilot Commission's ability to continue as a going concern for a reasonable period of time.

We are required to communicate with those charged with governance regarding, among other matters, the planned scope and timing of the audit, significant findings, and certain internal control related matters that we identified during the audit.

### **Other Matters**

In accordance with Government Auditing Standards, we have also issued our report dated September 3, 2024 on our consideration of the New Jersey Maritime Pilot and Docking Pilot Commission's internal control over financial reporting and on our tests of its compliance with certain provisions of laws, regulations, contracts and grant agreement and other matters. The purpose of that report is to describe the scope of our testing of internal control over financial reporting and compliance and the results of that testing, and not to provide an opinion on the internal control over financial reporting or on compliance. That report is an integral part of an audit performed in accordance with Government Auditing Standards and should be considered in assessing the results of our audit.

This report is intended solely for the information and use of the New Jersey Maritime Pilot and Docking Pilot Commission and management and is not intended to be used and should not be used by anyone other than those specified parties.

A handwritten signature in black ink, appearing to read 'Kayode Agunbiade', with a horizontal line underneath it.

Kayode Agunbiade & Co.  
Certified Public Accountants  
East Orange, New Jersey  
September 3, 2024

**The New Jersey Maritime Pilot and Docking Pilot Commission**  
**Statement of Financial Position**  
**For the Year End June 30, 2024 and 2023**

<b>ASSETS</b>	<b>2024</b>	<b>2023</b>
<b>Current Assets</b>		
Cash	\$ 125,578	\$ 125,274
Amount on account with State of New Jersey DOT	30,262	44,546
Fixed Assets	<u>1,146</u>	<u>-</u>
Total Assets	<u>\$ 156,986</u>	<u>\$ 169,820</u>
 <b>LIABILITIES AND NET ASSETS</b>		
<b>Current Liabilities</b>		
Accounts payable	<u>\$ 7,000</u>	<u>\$ 6,000</u>
Total Current Liabilities	7,000	6,000
Net Assets, with donors restriction	-	-
Net Assets, without donors restriction	<u>149,986</u>	<u>163,820</u>
Total Current Liabilities and Unrestricted Net Assets	<u>\$ 156,986</u>	<u>\$ 169,820</u>

**The New Jersey Maritime Pilot and Docking Pilot Commission**  
**Statement of Activities**  
**For the Year End June 30, 2024 and 2023**

	2024	2023
<b>Revenue:</b>		
Statutory fee income	\$ 857,259	\$ 754,328
	<u>857,259</u>	<u>754,328</u>
	<u>\$ 857,259</u>	<u>\$ 754,328</u>
<b>Expenses:</b>		
Payroll and taxes	\$ 199,882	\$ 186,147
Commissioner's compensation	168,000	168,000
Fringe benefits	283,636	241,276
Rent	29,844	28,932
Office supplies and equipment	8,744	1,596
Professional fees	7,000	10,500
Meetings	2,066	961
Commissioner incidentals	2,489	686
Newspaper announcements	1,165	935
Pilot training	12,443	5,000
Miscellaneous	81,993	55,363
Travel	1,569	2,812
Annual membership	3,000	3,000
Awards and plaques	-	369
Conferences	3,140	1,700
Dues and subscription	1,546	873
ID/Badges/Wallets	345	1,270
Occurrence investigations	6,825	3,600
Supplies	-	1,307
Continuing education	-	1,360
Printing and reproduction	1,388	2,295
Utilities/Telephone	1,565	1,062
Annual parking	4,560	4,146
Legislative cruise	-	575
Harbor inspection tour	6,033	6,679
	<u>827,233</u>	<u>730,444</u>
Total Expenses	\$ 827,233	\$ 730,444
Increase (Decrease) in Net Assets	30,026	23,884
Net Assets, Beginning of Year, net of adjustments	<u>139,936</u>	<u>139,936</u>
Net Assets, End of Year	<u>\$ 169,962</u>	<u>\$ 163,820</u>

The notes to the financial statements are an integral part of these statements

**The New Jersey Maritime Pilot and Docking Pilot Commission**  
**Statement of Cash Flows**  
**For the Year End June 30, 2024 and 2023**

	2024	2023
Cash Flows from Operating Activities:		
Increase (Decrease) in net assets	\$ 30,027	\$ 23,884
Adjustments to Reconcile Increase in Fund Balance to		
Net Cash (Used in) Provided by Operating Activities:	(43,851)	(7,770)
Change in Operating Assets and Liabilities:		
Amount on account with State of New Jersey/DOT	14,284	4,648
Statutory fees Receivable	-	-
Accounts receivable	-	7,500
Accounts payable	1,000	(6,000)
Net change in Fixed assets	(1,156)	-
Net Cash (Used in) Provided by Operating Activities	<u>304</u>	<u>22,262</u>
and Net (Decrease) Increase in Cash		
Cash - Beginning of Year	<u>125,274</u>	<u>134,932</u>
Cash - End of Year	<u>\$ 125,578</u>	<u>\$ 112,670</u>

**The New Jersey Maritime Pilot and Docking Pilot Commission**  
**Notes to Financial Statements**  
**For the year ended June 30, 2024 and 2023**

**Note 1 – Nature of Organization and Summary of Significant Accounting Policies**

The New Jersey Maritime Pilot and Docking Pilot Commission (the “Commission”) is a public agency, created by the New Jersey State Legislature, Laws of 1837, as amended, to provide for the competitive selection, training, licensing and regulation of State Pilots, who navigate large seagoing vessels, as they enter the Port of New Jersey/New York (the “Port”), travel within the respective waterways and depart from the Port. The Commission statutorily has six Commissioner slots but only 4 are currently occupied. The Commissioners are appointed by the Governor. The Commission’s administrative expenses are funded by the statutory prescribed fees received by New Jersey licensed maritime pilots and docking pilots and these funds are received and held by New Jersey Department of Transportation (“NJDOT”). NJDOT provides certain administrative services, primarily payroll and accounting services, to the Commission and reimburses the Commission from the Commission’s funds, those amounts expended from the Commission’s bank account.

**Basis of Accounting Presentation**

The accompanying financial statements of the New Jersey Maritime Pilot and Docking Pilot Commission have been prepared on the accrual basis of accounting in accordance with generally accepted accounting principles.

The Assets of the Commission are used solely for the purpose described above, therefore, it has not been necessary and, accordingly, no resolution restricting the net assets of the Commission has been adopted.

**Estimates**

The preparation of financial statements in conformity with generally accepted accounting principles requires management to make estimates and assumptions that affect the reported amounts of assets and liabilities and disclosure of contingent assets and liabilities at the date of the consolidated financial statements and the reported amounts of revenues and expenses during the reporting period. Actual results could differ from those estimates.

**Revenue Recognition and Receivables**

Revenues are recognized in the period pilot services are provided and consist primarily of pilot fees that are reported at estimated net realizable amounts, which are used to support various programs.

Statutory fees receivable is recorded at the net realizable value and does not bear interest. There is no allowance recorded at June 30, 2024 and 2023.

**Risk and Uncertainties**

The Commission’s significant credit risk is the amount on account from the State of New Jersey/DOT. There is a potential for the State of New Jersey to appropriate surplus funds to subsidize New Jersey State budget deficiencies. Due to this level of risk, it is at least reasonably possible that changes in funds available to the Commission will occur in the near term and such changes could materially affect the amounts reported in the accompanying financial statements.

**The New Jersey Maritime Pilot and Docking Pilot Commission**  
**Notes to Financial Statements**  
**For the year ended June 30, 2024 and 2023**

**Financial Instruments**

The carrying values of the Commission's financial instruments as of June 30, 2024 include cash, receivables and amounts on account with the State of New Jersey/DOT approximate their market value due to the relatively short maturity of these instruments.

**Fair Value Disclosure**

The Commission has provided fair value disclosure information for relevant assets and liabilities in these financial statements.

For applicable assets and liabilities subject to the provisions of fair value measurements under FASB ASC 820, the Commission will value, such assets and liabilities using quoted market process in active markets for identical assets and liabilities to the extent possible. To the extent that such market prices are not available, management will next attempt to value such assets and liabilities using observable measurement criteria, including quoted market prices of similar assets and liabilities in active and inactive markets and other corroborated factors. In the event that quoted market prices in active markets for identical assets and liabilities (Level 1) and other observable measurement criteria (Level 2) or unobservable inputs that are not available (Level 3), the Commission will develop measurement criteria based on the best information available, including information from banking institutions and advisors. All of the Commission's financial assets are Level 1 inputs.

**Concentrations of Credit Risk**

Financial instruments, which potentially subject the Commission to concentrations of credit risk, consist principally of cash, receivables and amount on account with the State of New Jersey/DOT. The Commission places its cash with high credit quality financial institutions. The Commission monitors the financial condition of the banking institutions, along with their cash balances to minimize this risk.

**Amount on account with the State of New Jersey/DOT**

The State of New Jersey/DOT maintains a non-interest bearing account on behalf of the Commission with the State of New Jersey's control. The account is used to receive substantial all fees, as well as to pay various expenses, on behalf of the Commission. As of June 30, 2024 and 2023, the State of New Jersey owed the Commission \$44,546 and 30,262 respectively. The amounts was confirmed with the State of New Jersey.

The classes of Net Assets are defined as follows:

**Classification of net assets**

The Organization net assets, revenues, and expenses are classified based on the existence or absence of donor imposed restrictions in accordance with Financial Accounting Standards Board's Accounting standards codification ("FASB ASC") No. 958-200005-05. "Presentation of Financial Statements for Not-for-Profit Entities". It requires that the amount for each of the classes of net assets be displayed in the Statement of financial position and that the amounts of change in each of those classes of net assets be displayed in the statement of activities and change in net assets.

**The New Jersey Maritime Pilot and Docking Pilot Commission**  
**Notes to Financial Statements**  
**For the year ended June 30, 2024 and 2023**

Net assets without donor restrictions: include net assets that are not subject to donor-imposed restrictions and may be expended for any purpose in performing the primary objectives of the organization. The organization's board may designate assets without restrictions for specific operational purposes from time to time.

Net assets with donor restrictions: Net assets subject to stipulation imposed by donors and grantors. Some donor restrictions are temporary in nature; those restrictions will be met by actions of the Non-Profit Organization or by the passage of time. Other donor restrictions are perpetual in nature, whereby the donor has stipulated the funds be maintained in perpetuity.

**Pension Plan**

Commission employees are considered employees of the State of New Jersey and participate in the Public Employees' Retirement System ("PERS" or "System") which has been established by the state statute. The Division of Pensions and Benefits (the "Division") within the Treasury Department of the State of New Jersey is the administrator of the plan. According to the state of New Jersey Administrative Code, all obligations of the system will be assumed by the State of New Jersey should the system terminate. The PERS is considered a cost-sharing multiple-employer plan.

The Public Employees' Retirements System was established in January 1955 and significantly amended October 29, 2015 under the provisions of N.J.S.A. 43:15A to provide coverage including post-retirement healthcare to substantially all full time employees of the State or any county, municipality, school district or public agency provided the employee is not a member of another State administered retirement system. The 2010 legislation implemented the "tiered" system whereby employees are eligible for benefits based upon their date of hire, number of weekly hours worked and annual salary. Vesting for pension benefits occurs after 10 years of service and 25 years of service for health care coverage. Members are eligible for retirement at age 60 for Tier 1 and Tier 2 employees at age 62 for Tier 3 and 4 employees with an annual

Benefit Tier generally determined to be  $1/55^{\text{th}}$  of the final average salary for Tier 1, 2 and 3 employees and  $1/60^{\text{th}}$  of the final average salary for Tier 4 employees multiplied by the number of years of service. Early retirement is available to those under normal retirement age with 25 or more years of credited service, but at a reduced rate.

The State of New Jersey, Department of the Treasury, Division of Pensions and Benefits, issues publicly available financial reports that include the financial statements and required supplementary information for PERS. As of June 30, 2024 and 2023 the aggregate funded ratio and unfunded accrued liability for local PERS obligations was 58.8 % and \$7,177 billion, respectively. The financial report may be obtained by writing to the State of New Jersey, Department of the treasury, Division of Pension and Benefits. P.O. Box 295, Trenton, New Jersey, 08625-0295 or through the Division of Pension and Benefits website at [www.state.nj.ustreasury/pensions](http://www.state.nj.ustreasury/pensions).

**The New Jersey Maritime Pilot and Docking Pilot Commission**  
**Notes to Financial Statements**  
**For the year ended June 30, 2024 and 2023**

**Pension Plan (Continued)**

Scope of Operations as of June 30, 2022 (The Financial Statements for June 30, 2025 is not available as of this date).

The Scope of Operations consist of 13 Programs as follows:

- Alternate Benefit Program (ABP)
- Prison Officers' Pension Fund (POPF)
- Consolidated Police and Firemen's Pension Fund (CPFPPF)
- New Jersey State Employees Deferred Compensation Plan (NJSEDCP)
- Supplemental Annuity Collective Trust (SACT)
- Additional Contributions Tax Sheltered Programs (ACTS)
- Central Pension Fund (CPF)
- Unemployment Compensation and Temporary Disability Insurance for State Employee (UC/TDI)

- State Health Benefits Program (SHBP)
- Prescription Drug Plan (PDP)
- Employee Dental Plan (EDP)
- Tax\$ave
- Commuter Tax\$ave
- Long Term Care Insurance Plan

Active membership in the Retirement system in 2024 were 541,004 and Retired Members were 361,419 with a total Assets of \$98,448,537,864 as of June 30, 2024 with a corresponding liabilities of \$95,306,367,360 as of same period. This is the latest data available.

**Operating Lease:**

The commission leases a 620 square feet office space on the 9<sup>th</sup> floor of the New Jersey Transit Authority headquarters located at One Penn Plaza Newark, NJ 07105. The lease is a 9-year lease with a monthly payment of \$2,500 or an annual payment of \$29,844.

**Subsequent Events:**

The Commission has evaluated subsequent events occurring after June 30, 2024 through September 3, 2024 which is the date the financial statements were available to be issued. Based on this evaluation, the Commission has determined that no subsequent events have occurred which require disclosure in the financial statements.

RESOLUTION APPROVING LIST OF QUALIFIED APPRENTICES

WHEREAS, Pursuant to N.J.A.C. 16:64-2.2 applications have been received for entry into the Maritime Pilot apprentice training program, and

WHEREAS, the applicants have been evaluated by a Selection Committee as provided for in N.J.A.C. 16:64-2.3(b), and

WHEREAS, the Selection Committee has made a recommendation to the Commission of the ten highest ranked applicants and five alternates, and

WHEREAS, the Commission is satisfied with the Committee's recommendations.

NOW, THEREFORE BE IT RESOLVED, BY THE NEW JERSEY MARITIME PILOT AND DOCKING PILOT COMMISSION, that the attached list of qualified applicants, be approved for a period of two years as provided for in N.J.A.C. 16:64-2.3(d).

UNITED NEW YORK SANDY HOOK PILOTS' BENEVOLENT ASSOCIATION  
AND  
UNITED NEW JERSEY SANDY HOOK PILOTS' BENEVOLENT ASSOCIATION

September 23, 2024

Commissioner Timothy J. Dacey  
New Jersey Maritime Pilot and  
Docking Pilot Commission  
One Penn Plaza East, 9<sup>th</sup> Floor  
Newark, NJ 07105

Dear Commissioner Dacey:

I am pleased to report that the 2024 Apprentice Selection Committee has concluded its work by compiling a ranked list of ten applicant apprentice candidates, plus five alternates. Our inclusion of five alternates was meant to have extra candidates listed in the event they are needed due to any unforeseen events with background checks prior to ratification by the Board, and also to provide an indication of confidence to these candidates to return for the next round.

This process began with advertisements in industry publications and notices to northeast maritime colleges in February/March. A generous time allotment was provided to receive completed applications. All applications were reviewed - either accepted or denied based on each applicant meeting the stated requirements in the regulations of this Commission. Applicants were then notified to schedule testing and interviewing with the Institute for Forensic Psychology over the summer. Results were then distributed to the committee membership prior to the next phase of interviews. This committee reviewed all appropriate information available on each candidate and then conducted interviews during the past two weeks.

We consistently explained the training program and expectations of the Associations to each candidate, plus the oversight obligation of the states. The interview process was spread over two weeks and required the undivided attention of all participants. Represented in the committee were two licensed Pilots from New York, two licensed Pilots from New Jersey, one New Jersey pilot commissioner representative, and one New York pilot commissioner representative. All committee members were prepared, diligent, engaged, and committed to the success of this process.

We have completed our work by forwarding this list of applicant apprentice candidates for your review and ratification. If you require any additional information, please let me know. After this diligent effort, it is our sincere recommendation that this list be ratified by the Board, pending the outcome of an additional background check to verify the information already submitted to the Committee.

## **2024 Applicant Apprentice List**

Liam Gagliano  
Ryan Dashkoff  
Gage Reamy  
Ryan Wood  
Karsten Tribus  
Paul Paris  
Charlie Russell  
Michael Brantmeyer  
Niall Gallagher  
Konrad Biedermann

### **Five Alternates**

Joseph Kiernan  
James Bonner  
Thomas Leuck  
Ryan Bruett  
Casey Meekins

I would like to personally thank all the members of the Apprentice Selection Committee for their untiring participation throughout the selection process which stretched over several months.

If you have any further questions or concerns, please do not hesitate to contact me directly.

Sincerely,

Captain Charles J. Mayrer Jr.  
Chairman of 2024 Apprentice Selection Committee

Cc: Timothy J. Dacey, Commissioner  
New Jersey Maritime Pilots & Docking Pilots Commission  
Ms. Andre Stuckey, Executive Director  
New Jersey Maritime Pilots & Docking Pilots Commission  
Captain Brendan L. Foley  
Captain John L. Flanders  
Captain Timothy G. Newman



# The New Jersey Maritime Pilot & Docking Pilot Commission

One Penn Plaza East \* 9<sup>th</sup> Floor \* Newark, NJ 07105  
Tele: (973) 491-7693 \* Fax: (973) 491-4352  
Email: astuckey@njtransit.com

## MEMO

**TO:** New Jersey Maritime Pilot and Docking Pilot Commission

**FROM:** Andre M. Stuckey 

**CC:** Dorian Smith, Esq.  
Frederic Cohen, Esq.

**RE:** Maritime Pilot Apprentice Selection List

**DATE:** September 25, 2024

The Maritime Pilot Apprentice Selection Committee interviewed thirty-eight candidates to be considered for the Maritime Pilot Apprentice Selection List. Below is a summary of the ranked candidates.

### 1. Mr. Liam P. Gagliano

Mr. Gagliano graduated from The State University of New York Maritime College with a Bachelor of Science in Marine Transportation in 2017. He has First Class Pilotage in the Newark Bay, Kill Van Kull, Passaic River, Hackensack River and the Arthur Kill North. He holds a Chief Mate Unlimited license, 1600 Ton Master license, and Mate of Towing license. He is currently working as a Chief Mate with Centerline Logistics on an ATB in their offshore fleet. Mr. Gagliano was ranked "Highly Recommended" for the position sought by the Institute for Forensic Psychology.

### 2. Mr. Ryan Dashkoff

Mr. Dashkoff graduated from the State University of New York Maritime College with a Bachelor of Science in Marine Transportation in 2018. He has First Class Pilotage for the Kill Van Kull, Arthur Kill North, Arthur Kill South, Upper Bay and the Newark Bay. He holds a Second Mate Unlimited license, Master of Towing license and a 1600 Ton Master license. He is currently working as a Chief Mate for Centerline Logistics on an ATB in their offshore fleet. Mr. Dashkoff was ranked "Highly Recommended" for the position sought by the Institute for Forensic Psychology.

### 3. Mr. Gage Reamy

Mr. Reamy graduated from Massachusetts Maritime Academy with a Bachelor of Science in Marine Transportation in 2020. He holds a Chief Mate Unlimited license on Self-Propelled Vessels. He currently works as a Chief Officer with Tote Marine Services. Mr. Reamy was ranked "Recommended" for the position sought by the Institute for Forensic Psychology.

#### **4. Mr. Ryan Wood**

Mr. Wood graduated from the State University of New York Maritime College with a Bachelor of Science in Marine Transportation in 2017. He holds a Second Mate Unlimited license and a Mate of Towing license. He is currently working as an Able Seaman for Reinauer Transportation on the ATB *Haggerty Girls*. Mr. Wood was ranked "Recommended" for the position sought by the Institute for Forensic Psychology.

#### **5. Mr. Karsten Tribus**

Mr. Tribus graduated from the United States Merchant Marine Academy with a Bachelor of Science in Marine Transportation in 2020. He has First Class Pilotage for the Arthur Kill South, Arthur Kill North, Kill Van Kull and Newark Bay. He holds a Second Mate Unlimited Oceans license, Master 1600 Ton license, and a Master of Towing license. He currently works as a Chief Mate for Centerline Logistics as a floater for their assets in the New York harbor. Mr. Tribus was ranked "Highly Recommended" for the position sought by the Institute for Forensic Psychology.

#### **6. Mr. Paul Paris**

Mr. Parish graduated from the State University of New York Maritime College with a Bachelor of Science in Marine Operations Deck in 2017. He has First Class Pilotage in the Kill Van Kull and Newark Bay. He holds a 1600 Ton Masters license and a Second Mate license. He currently works for McAllister Towing as a Tug Captain. He also works for JFPF Fishing Boats, Inc as a Captain and APD Fishing, Inc. as an Owner/Operator. Mr. Parish was ranked "Highly Recommended" for the position sought by the Institute for Forensic Psychology.

#### **7. Charles Russell**

Mr. Russell graduated from the United States Merchant Marine Academy with a Bachelor of Science in Maritime Logistics and Security in 2020. He holds a 1600 Ton Masters license, and a Second Mate Unlimited license. He currently works for Crowley as a Deck Officer and is a Junior Lieutenant in the United States Navy Reserve. Mr. Russell was ranked "Recommended" for the position sought by the Institute for Forensic Psychology.

#### **8. Michael Brantmeyer**

Mr. Brantmeyer graduated from the State University of New York Maritime College with a Bachelor of Science in Marine Transportation in 2019. He holds a Third Mate Unlimited license and a Master of Towing license. He currently works as a Tug Captain for Kirby

Inland Marine and a laborer for his family business Cobbleking. Mr. Brantmeyer was ranked “Highly Recommended” for the position sought by the Institute for Forensic Psychology.

#### **9. Mr. Niall Gallagher**

Mr. Gallagher graduated from the United States Naval Academy with a Bachelor of Science in Quantitative Economics in 2019. He has served in the United States Marine Corps since 2019 and is currently serving as the Officer Selection Officer. Mr. Gallagher was ranked “Highly Recommended” for the position sought by the Institute for Forensic Psychology.

#### **10. Mr. Konrad Biedermann**

Mr. Biedermann graduated from the State University of New York Maritime College with a Bachelor of Science in Engineering and Naval Architecture in 2021. He holds a Third Mate Safety Officer license and a Second Mate Radio Officer license. He currently works for Overseas Shipholding Group as a Second Mate Navigational Officer. Mr. Biedermann was ranked “Highly Recommended” for the position sought by the Institute for Forensic Psychology.

#### **11. Mr. Joseph Kiernan**

Mr. Kiernan graduated from the State University of New York Maritime College with a Bachelor of Science in Marine Transportation in 2023 and is working towards his Master of Science. He is currently working for Seabulk Tankers, Inc. as a Third Mate Deck Officer and a Pompous Boat Operator, Dockmaster and Lifeguard for the Village of Northport. Mr. Kiernan was ranked as “Recommended” for the position sought by the Institute for Forensic Psychology.

#### **12. Mr. James Bonner**

Mr. Bonner graduated from the State University of New York Maritime College with a Bachelor of Science in Marine Transportation in 2019. He holds a 1600 Ton Masters license, a Master of Towing license and a Chief Mate License. He currently works for Edison Chouest Offshore as a Chief mate and is a Lieutenant in the United States Navy Reserve. Mr. Bonner ranked “Highly Recommended” for the position sought by the Institute for Forensic Psychology.

#### **13. Thomas Leuck**

Mr. Leuck graduated from the United States Merchant Marine Academy with a Bachelor of Science in Marine Logistics and Security in 2023. He holds a 100 Ton Masters license and a Third Mate Unlimited license. He currently works for Moran Towing and Transportation as an Able Seaman on the tug *Kirby Moran* and is serving his eight-year commitment in the United States Navy Reserve. Mr. Leuck was ranked “Highly Recommended” for the position sought by the Institute for Forensic Psychology.

#### **14. Mr. Ryan Bruett**

Mr. Bruett graduated from the State University of New York Maritime College with a Bachelor of Science in Marine Transportation in 2019. He holds a 1600 Ton Masters license and a Chief Mate license. He is currently working for Genesis Marine as a Chief Mate. Mr. Bruett was ranked “Highly Recommended” by the Institute for Forensic Psychology.

#### **15. Mr. Casey Meekins**

Mr. Meekins graduated from the State University of New York Maritime College with a Bachelor of Science in Marine Transportation and Naval Science in 2021. He holds a Third Mate Unlimited license. He currently works for Hornbeck Offshore Services as a Third Mate and is currently serving as a Junior Lieutenant in the United States Navy Reserve. Mr. Meekins was ranked “Recommended” for the position sought by the Institute for Forensic Psychology.

A resolution will be on the agenda for your October 15, 2024, meeting to approve the list. Once the list is approved the Sandy Hook Pilots Association intends to call the first person off the list to begin his apprenticeship on December 1, 2024.

RESOLUTION TO APPROVE THE UPGRADE OF CAPTAIN SCOTT T. BRITTON

WHEREAS, Pursuant to N.J.A.C. 16:64-3.5 all increases in grade for Maritime Pilots shall be approved by the New Jersey Maritime Pilot and Docking Pilot Commission, and

WHEREAS, Captain Scott T. Britton has submitted the proper notice requesting an increase in Grade to a Pilot of the Fourth Grade, and

WHEREAS, the Operations Manager has reviewed Captain Britton's performance and recommends him for a six month increase in grade, and

WHEREAS, the Sandy Hook Pilots' Association posted the schedule of advancement at the pilots' headquarters and aboard the station, and

WHEREAS, no negative comments were received.

NOW THEREFORE BE IT RESOLVED BY the New Jersey Maritime Pilot and Docking Pilot Commission that the request for an increase in grade by Captain Scott T. Britton is hereby approved effective October 1, 2024.

## Stuckey, Andre (CPILAXS)

---

**From:** Christopher Maglin <CMaglin@sandyhookpilots.com>  
**Sent:** Monday, September 30, 2024 12:33 PM  
**To:** Stuckey, Andre (CPILAXS)  
**Cc:** Timothy Ferrie  
**Subject:** Captains Scott Britton & Luke Carrick

**CAUTION:** This e-mail originated from outside of NJ TRANSIT. Do not click links or open attachments unless you recognize the sender and know the content is safe.

Hi Andre,

Captain Scott Britton and Captain Luke Carrick have fulfilled all prerequisites allowing for an application to advance in Pilot grade on 10/1/2024.

Scott Britton: 5 to 4  
Luke Carrick: 6A to 6

Consideration by the NJ Maritime Pilot and Docking Pilot Commission is appreciated.

If you need anything else from us, please don't hesitate.

Regards,  
Christopher Maglin  
Director, Operations  
Sandy Hook Pilots Association  
718-448-3900 (office)  
347-466-1071 (mobile)

### Disclaimer

The information contained in this communication from the sender is confidential. It is intended solely for use by the recipient and others authorized to receive it. If you are not the recipient, you are hereby notified that any disclosure, copying, distribution or taking action in relation of the contents of this information is strictly prohibited and may be unlawful.

This email has been scanned for viruses and malware, and may have been automatically archived by Mimecast, a leader in email security and cyber resilience. Mimecast integrates email defenses with brand protection, security awareness training, web security, compliance and other essential capabilities. Mimecast helps protect large and small organizations from malicious activity, human error and technology failure; and to lead the movement toward building a more resilient world. To find out more, visit our website.

RESOLUTION TO APPROVE THE UDGRADE OF CAPTAIN LUKE J. CARRICK

WHEREAS, Pursuant to N.J.A.C. 16:64-3.5 all increases in grade for Maritime Pilots shall be approved by the New Jersey Maritime Pilot and Docking Pilot Commission, and

WHEREAS, Captain Luke J. Carrick has submitted the proper notice requesting an increase in Grade to a Pilot of the Sixth Grade, and

WHEREAS, the Operations Manager has reviewed Captain Carrick's progress and recommends him for a six month increase in grade, and

WHEREAS, the Sandy Hook Pilots' Association posted the schedule of advancement at the pilots' headquarters and aboard the station, and

WHEREAS, no negative comments were received.

NOW THEREFORE BE IT RESOLVED BY the New Jersey Maritime Pilot and Docking Pilot Commission that the request for an increase in grade by Captain Luke J. Carrick is hereby approved effective October 1, 2024.

## Stuckey, Andre (CPILAXS)

---

**From:** Christopher Maglin <CMaglin@sandyhookpilots.com>  
**Sent:** Monday, September 30, 2024 12:33 PM  
**To:** Stuckey, Andre (CPILAXS)  
**Cc:** Timothy Ferrie  
**Subject:** Captains Scott Britton & Luke Carrick

**CAUTION:** This e-mail originated from outside of NJ TRANSIT. Do not click links or open attachments unless you recognize the sender and know the content is safe.

Hi Andre,

Captain Scott Britton and Captain Luke Carrick have fulfilled all prerequisites allowing for an application to advance in Pilot grade on 10/1/2024.

Scott Britton: 5 to 4  
Luke Carrick: 6A to 6

Consideration by the NJ Maritime Pilot and Docking Pilot Commission is appreciated.

If you need anything else from us, please don't hesitate.

Regards,  
Christopher Maglin  
Director, Operations  
Sandy Hook Pilots Association  
718-448-3900 (office)  
347-466-1071 (mobile)

### Disclaimer

The information contained in this communication from the sender is confidential. It is intended solely for use by the recipient and others authorized to receive it. If you are not the recipient, you are hereby notified that any disclosure, copying, distribution or taking action in relation of the contents of this information is strictly prohibited and may be unlawful.

This email has been scanned for viruses and malware, and may have been automatically archived by Mimecast, a leader in email security and cyber resilience. Mimecast integrates email defenses with brand protection, security awareness training, web security, compliance and other essential capabilities. Mimecast helps protect large and small organizations from malicious activity, human error and technology failure; and to lead the movement toward building a more resilient world. To find out more, visit our website.

RESOLUTION TO APPROVE THE UPGRADE OF CAPTAIN PAUL TORRES, III

WHEREAS, Pursuant to N.J.A.C. 16:64-3.5 all increases in grade for Maritime Pilots shall be approved by the New Jersey Maritime Pilot and Docking Pilot Commission, and

WHEREAS, Captain Paul Torres, III has submitted the proper notice requesting an increase in Grade to a Pilot of the Second Grade, and

WHEREAS, the Sandy Hook Pilots' Association posted the schedule of advancement at the pilots' headquarters and aboard the station boat, and

WHEREAS, no negative comments were received.

NOW THEREFORE BE IT RESOLVED BY the New Jersey Maritime Pilot and Docking Pilot Commission that the request for an increase in grade by Captain Paul Torres, III is hereby approved and shall become effective on November 1, 2024.

UNITED NEW JERSEY SANDY HOOK PILOTS' ASSOCIATION

Date: October 7, 2024  
To: New Jersey Maritime Pilot & Docking Pilot Commission  
From: Captain Timothy J. Ferrie, President  
Re: License Upgrade (November 2024)

Please note that on November 1, 2024, Captain Paul Torres III will have fulfilled all prerequisites allowing for his application to advance in Pilot Grade.

As of November 1, 2024, Captain Torres III will have completed 12 months of service as Pilot of the 3<sup>rd</sup> Grade (45'/90k GRT) and will be applying for an upgrade to Pilot of the 2<sup>nd</sup> Grade (48'/150 GRT).

Notification of his eligibility for a Pilot Grade advancement has been distributed to all Pilots for their review. Consideration by the New Jersey Maritime Pilot and Docking Pilot Commission is very much appreciated.

Respectfully,

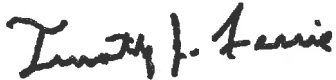

Captain Timothy J. Ferrie  
President

RESOLUTION TO APPROVE THE UPGRADE OF CAPTAIN JAMES P. BRITTON

WHEREAS, Pursuant to N.J.A.C. 16:64-3.5 all increases in grade for Maritime Pilots shall be approved by the New Jersey Maritime Pilot and Docking Pilot Commission, and

WHEREAS, Captain James P. Britton has submitted the proper notice requesting an increase in Grade to a Pilot of the Third Grade, and

WHEREAS, the Sandy Hook Pilots' Association posted the schedule of advancement at the pilots' headquarters and aboard the station boat, and

WHEREAS, no negative comments were received.

NOW THEREFORE BE IT RESOLVED BY the New Jersey Maritime Pilot and Docking Pilot Commission that the request for an increase in grade by Captain James P. Britton is hereby approved and shall become effective on November 1, 2024.

UNITED NEW JERSEY SANDY HOOK PILOTS' ASSOCIATION

Date: October 7, 2024  
To: New Jersey Maritime Pilot & Docking Pilot Commission  
From: Captain Timothy J. Ferrie, President  
Re: License Upgrade (November 2024)

Please note that on November 1, 2024, Captain James P. Britton will have fulfilled all prerequisites allowing for his application to advance in Pilot Grade.

As of November 1, 2024, Captain Britton will have completed 12 months of service as Pilot of the 4<sup>th</sup> Grade (42'/80k GRT) and will be applying for an upgrade to Pilot of the 3<sup>rd</sup> Grade (45'/90k GRT).

Notification of his eligibility for a Pilot Grade advancement has been distributed to all Pilots for their review. Consideration by the New Jersey Maritime Pilot and Docking Pilot Commission is very much appreciated.

Respectfully,

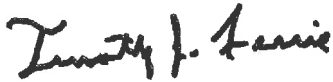

Captain Timothy J. Ferrie  
President

RESOLUTION TO APPROVE THE UDGRADE OF CAPTAIN PETER J. ROOSS, JR.

WHEREAS, Pursuant to N.J.A.C. 16:64-3.5 all increases in grade for Maritime Pilots shall be approved by the New Jersey Maritime Pilot and Docking Pilot Commission, and

WHEREAS, Captain Peter G. Rooss, Jr. has submitted the proper notice requesting an increase in Grade to a Pilot of the Sixth Grade, and

WHEREAS, the Sandy Hook Pilots' Association posted the schedule of advancement at the pilots' headquarters and aboard the station boat, and

WHEREAS, no negative comments were received.

NOW THEREFORE BE IT RESOLVED BY the New Jersey Maritime Pilot and Docking Pilot Commission that the request for an increase in grade by Captain Peter G. Rooss, Jr. is hereby approved and shall become effective on November 1, 2024.

UNITED NEW JERSEY SANDY HOOK PILOTS' ASSOCIATION

Date: October 7, 2024  
To: New Jersey Maritime Pilot & Docking Pilot Commission  
From: Captain Timothy J. Ferrie, President  
Re: License Upgrade (November 2024)

Please note that on November 1, 2024, Captain Peter G. Rooss Jr. will have fulfilled all prerequisites allowing for his application to advance in Pilot Grade.

As of November 1, 2024, Captain Rooss Jr. will have completed 6 months of service as Pilot of the 6th Grade (33'/45k GRT) and will be applying for an upgrade to Pilot of the 5<sup>th</sup>A Grade (35'/60k GRT).

Consideration by the New Jersey Maritime Pilot and Docking Pilot Commission is very much appreciated.

Respectfully,

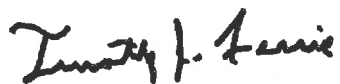

Captain Timothy J. Ferrie  
President



# The New Jersey Maritime Pilot & Docking Pilot Commission

One Penn Plaza East \* 9<sup>th</sup> Floor \* Newark, NJ 07105

Tele: (973) 491-7693 \* Fax: (973) 491-4352

Email: [astuckey@njtransit.com](mailto:astuckey@njtransit.com)

September 23, 2024

The Honorable Marie Cantwell  
Chair

The Honorable Ted Cruz  
Ranking Member

Committee on Commerce, Science and Transportation  
425 Hart Office Building  
Washington, DC 20510

Dear Chair Cantwell and Ranking Member Cruz:

We are writing in support of the attached, letter from the American Waterways Operators expressing their opposition to Sec. 354 of H.R. 7659, the Coast Guard Authorization Act of 2024, that would prohibit the establishment of anchorages on the Hudson River.

Anchorage are needed for safety, especially when conditions in the Hudson River are not optimal for safe navigation. Such conditions could include foul weather, ice, vessel traffic congestion, lack of available safe berthing, or crew fatigue. Anchorages in no way lead to increased traffic on the river but are a way of enhancing safety for vessels currently operating on the Hudson.

If enacted, Sec. 354 would prohibit anchorages on two-thirds of the Hudson River, thereby placing vessels and their crews at risk.

We urge you to oppose Sec. 354 of H.R. 7659.

Respectfully,

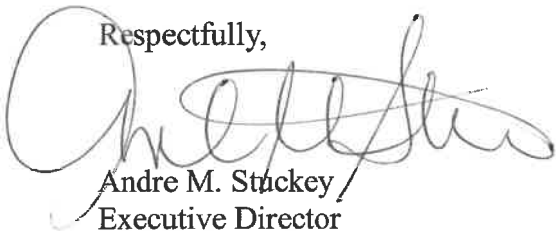

Andre M. Stuckey  
Executive Director

CC: American Waterways Operators

# HARBOR SAFETY, NAVIGATION AND OPERATIONS COMMITTEE

September 25, 2024

## Full Meeting Agenda

- **Introductions and Chairman's Report**
- **Captain of the Port Report**
  - Sector Commander Captain Jon Andrechik
- **Presentations**
  - None*
- **Old Business**
  - Williams/Transco Pipeline Maintenance Project
  - Bridges
  - CHPE Project
  - Hudson Tunnel Project/ Amtrak
- **New Business**
  - Vessel Wakes around the harbor
    - ◆ Incident in Harlem River
    - ◆ Update from Vessel Wake Committee
- **Agency Reports**
  - USCG/NOAA/US Army Corp of Engineers
  - Port Authority of NY & NJ
  - NJ DOT Office of Maritime Resources
  - NYC EDC
  - NY/NJ Shipping Association
  - MAPONY
  - MARAD
- **Sub-committee Reports**
  - Passenger Vessel Subcommittee
  - Harbor Education
  - Energy
  - Tug & Barge
  - Bulk Liquid Movement Subcommittee
  - Deep Draft Working Group
- **"Of Interest"**

**Future Meeting Dates: Oct 16, Nov 20**

# ROMER V. SANDY HOOK BENEFITS

## SUITABILITY TO CURRENT OPERATIONS

- **Adaptability:** Appropriate design and general arrangement for pilot transfer operations to ships and the offshore station pilot vessels
- **Seakeeping:** Appropriate design to operate in both protected bay waters as well as transit to and from the offshore pilot station in moderate to heavy weather
- **Maneuverability:** Excellent handling at high and low speed for pilot transfers to vessels underway, at anchor and to docks
- **Safety:** Jet propulsion provides increased level of safety during MOB recovery operations

# BENEFITS

## WATERJET PROPULSION

- Pilot Safety: no propellers, rudders or struts under the vessel during a man overboard event
- Improved Maneuverability & Increased Safety During Pilot Transfers:
  - Fast acceleration
  - Full directional control at all speeds
  - Greatly improved positioning control during transfer
  - No gearbox and shaft brake shifting delays inherent with propellers
- Improved high-speed efficiency compared to propellers
- Reduced debris strike damage compared to propellers

# M/B ROMER

## VESSEL PARTICULARS

- **Builder:** Kvichak Marine Industries, Seattle, Washington [2004]
- **Designer:** Camarc Design, United Kingdom
- **Construction:** Aluminum, Double Chine, Deep V Hull , LOA 75'
- **Engines:** **New** (2) Cummins KTA38-M2 w/ Turbos @1,350 HP each
- **Propulsion:** Hamilton 651 Water Jets, Single Station, Wheel Steering w. **New** AVX Controls
- **Transmission:** ZF Gears [6 Hours]
- **Generator:** **New** John Deere 4045TFM (JD4-65.0)
- **Capacity:** Pilothouse: 3; Salon: 8; Staterooms 3 [2 bunks each]

# P/B ROMER

## GENERAL ARRANGEMENT

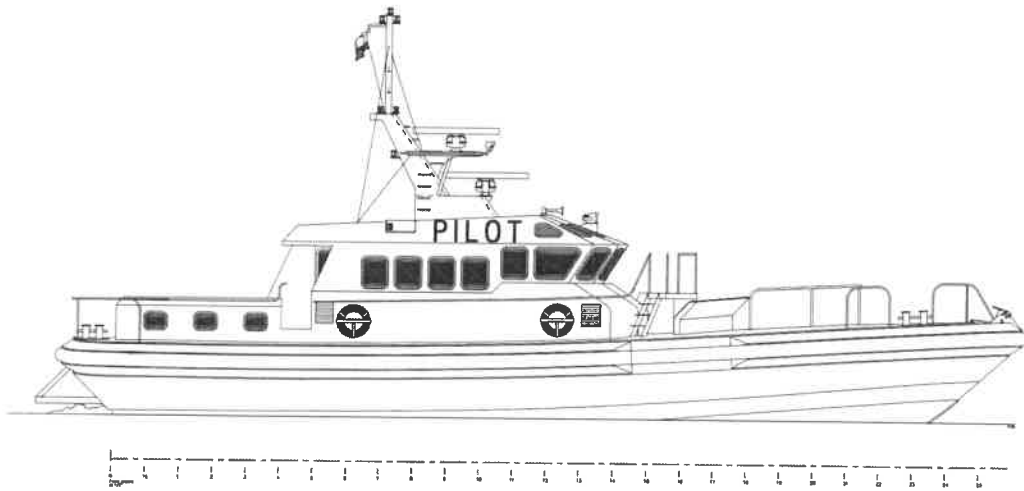

# GENERAL ARRANGEMENT

## PILOT HOUSE & ACCOMMODATIONS

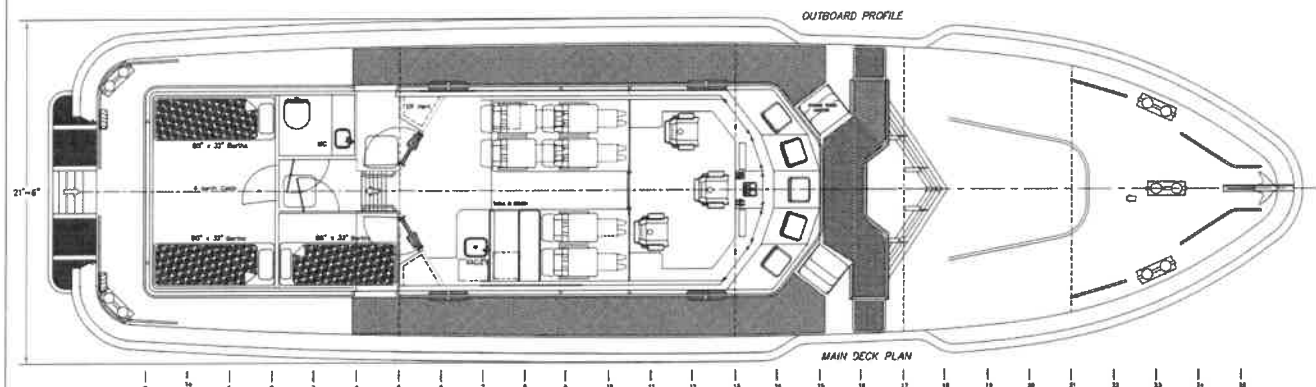

# GENERAL ARRANGEMENT

## STERN & PARTICULARS

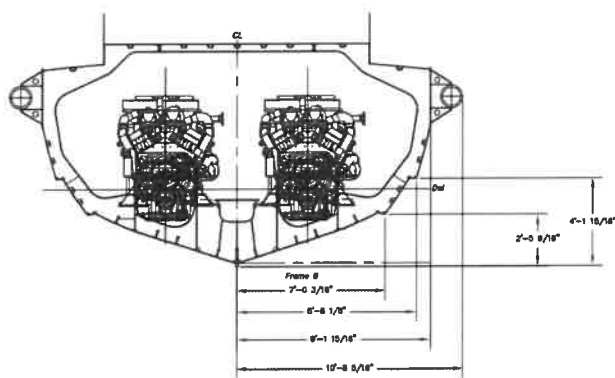

### Particulars

LOA	78.2'	23.8m
LOA (Ex Fender)	73.4'	22.4m
Length WL	64.2'	19.6m
Beam (Moulded)	18.4'	5.6m
Beam (Overall)	21.5'	6.5m
Draught	3.7'	1.1m

### GENERAL ARRANGEMENT

Drawing No P121/Sav01 Scale: 1/4" = 1' @ A1 By:arc.

## Kvichak

Marine Industries, Inc.  
469 NW Bowdoin Place, Seattle, WA. 98107  
TEL (206) 545-8485 FAX (206) 545-3504

### CAMARC DESIGN

©All rights reserved.  
CAMARC SMALL CRAFT DESIGNS.  
St Julians Hall, Shoreham by Sea,  
West Sussex, BN43 6RG. England UK.  
Email-Sales@camarc.com Web www.camarc.com

# GENERAL ARRANGEMENT

## PROFILE & MACHINERY SPACE

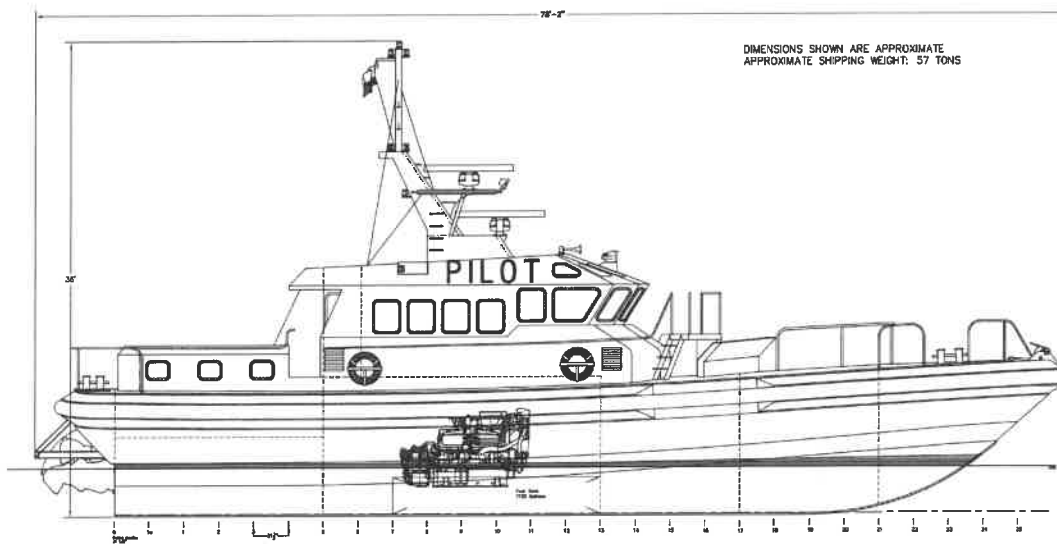

# GENERAL ARRANGEMENT

## JET ROOM & MACHINERY SPACE

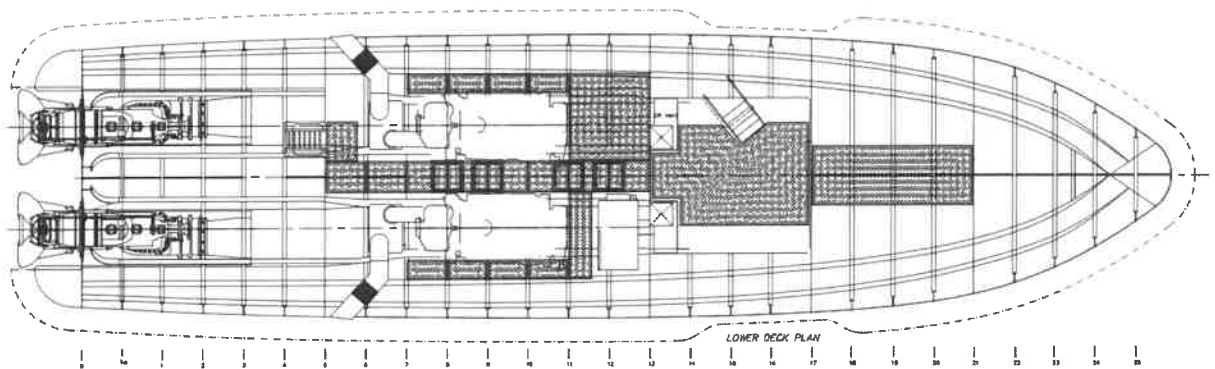

THE NEW JERSEY MARITIME PILOT AND DOCKING PILOT COMMISSION  
2025 PILOT ANNUAL APPEARANCE SCHEDULE

**January 21, 2025**

Jesse Malmgren  
Stephen Richter  
Karl Gadow  
Karen Nola  
Timothy Ferrie  
Paul Klein

**February 18, 2025**

Elizabeth Miller  
Ronald Perry  
Robert Flannery  
Charles Fannon  
Timothy Nilsen  
Sheldon Davis

**March 18, 2025**

Andrew Baeird  
Richard Wood  
Jonathan Miller  
Salvador Rivas  
\*\*Benjamin White  
Michael Vanek

**April 15, 2025**

Christopher Baker  
Adam Richardson  
Joseph Bosch  
Joseph Paulis  
Scott Britton  
Luke Carrick

**May 20, 2025**

Kirk Pinto  
William O'Neill

Thomas Ferrie  
Brian Paiva  
William Baeszler  
Michael Chambers  
\*\*Zachery Dietrich

**June 17, 2025**

Joseph Casaletto  
Donald Occhipinti  
Daniel Zorovich  
Leonard Evans  
Brendan Foley  
Nils Tribus  
Jon Flanders

**July 15, 2025**

\*\*Robert Oldmixon  
Harold Cavagnaro  
Graham Mergenthaler  
\*\*Matthew Keenan  
Randall Murphy  
Frank DiMatteo  
\*\*Steven Altini

**August 19, 2025**

Kevin Walsh  
\*\*James Jorgenson  
Mark Hershey  
Stephen Doherty  
Mark Wanderer  
William Speiser  
Ryan Pakalik

**September 16, 2025**

James R. Britton  
David Graves

Nicholas Pitch  
Craig Tomalo  
Alexander Woodworth  
Kevin Metkiff

**October 21, 2025**

Daniel Boylan  
Paul Torres  
James P. Britton  
Scott Esposito  
Kenneth Barsch  
Eric Lavin

**November 18, 2025**

Frank Reinbold  
Sean Meade  
Fred Dashkoff  
\*\*Luke Germanakos  
\*\*Kyle Sammis  
Peter Rooss

**December 16, 2025**

William Blake  
Coleen Quinn  
Adam Graves  
Russell Henchmann  
Douglas Mattson  
William Clifford

\*\* = Apprentice; Blue = Sandy Hook; Green = Metro; Purple – Interport; Red = Harbor