

CHAPTER 21**RESIDENTIAL SITE IMPROVEMENT STANDARDS****Authority**

N.J.S.A. 40:55D-40.4.

Source and Effective Date

R.2002 d.197, effective May 30, 2002.
See: 33 N.J.R. 3391(a), 34 N.J.R. 2311(b).

Expiration Date

Chapter 21, Residential Site Improvement Standards, expires on May 30, 2007.

Chapter Historical Note

Chapter 21, Uniform Standards Code for Mobile Homes, was adopted pursuant to authority of N.J.S.A. 52:2D-25.1 et seq. and was filed and became effective December 7, 1972, as R.1972 d.248. See: 4 N.J.R. 260(f), 5 N.J.R. 7(a).

Chapter 21, Uniform Standards Code for Mobile Homes, was amended by R.1974 d.275, effective January 1, 1975. See: 6 N.J.R. 343(a), 6 N.J.R. 427(b); and R.1975 d.166, effective July 1, 1975. See: 7 N.J.R. 200(a), 7 N.J.R. 306(a).

Chapter 21, Uniform Standards Code for Mobile Homes, was repealed by R.1982 d.7, effective February 1, 1982. See: 13 N.J.R. 717(a), 14 N.J.R. 142(a).

Chapter 21, Residential Site Improvement Standards, was adopted as R.1997 d.5, effective January 6, 1997 (operative June 3, 1997). See: 28 N.J.R. 2671(a), 28 N.J.R. 3491(a), 29 N.J.R. 159(a).

The name of Subchapter 1, General Provisions, was changed to General Guidelines by Administrative Correction. See: 29 N.J.R. 2816(a).

Petition for Rulemaking. See: 32 N.J.R. 2621(b).

Chapter 21, Residential Site Improvement Standards, was readopted as R.2002 d.197, effective May 30, 2002. See: Source and Effective Date.

CHAPTER TABLE OF CONTENTS**SUBCHAPTER 1. GENERAL GUIDELINES**

- 5:21-1.1 Title; division into subchapters
- 5:21-1.2 Authority
- 5:21-1.3 Intent and purpose
- 5:21-1.4 Definitions and abbreviations
- 5:21-1.5 Scope and applicability
- 5:21-1.6 Development over limestone geologic formations
- 5:21-1.7 Administration and enforcement
- 5:21-1.8 Approval
- 5:21-1.9 Violations
- 5:21-1.10 Operative date
- 5:21-1.11 Validity

APPENDIX. NEW JERSEY MUNICIPALITIES—LIMESTONE AREAS**SUBCHAPTER 2. APPLICATION AND REVIEW PROCEDURES**

- 5:21-2.1 Application and review procedures
- 5:21-2.2 Application form and checklist (Reserved)

SUBCHAPTER 3. EXCEPTIONS, WAIVERS, AND SPECIAL AREA STANDARDS

- 5:21-3.1 Exceptions
- 5:21-3.2 Waiver request
- 5:21-3.3 Waiver review
- 5:21-3.4 Appeal of waiver decisions
- 5:21-3.5 Special area standards
- 5:21-3.6 Agreement to exceed standards
- 5:21-3.7 Public meetings
- 5:21-3.8 Changes to the standards

SUBCHAPTER 4. STREETS AND PARKING

- 5:21-4.1 Street hierarchy
- 5:21-4.2 Cartway width
- 5:21-4.3 Curbs or curbs and gutters
- 5:21-4.4 Shoulders
- 5:21-4.5 Sidewalks and graded areas
- 5:21-4.6 Bikeways
- 5:21-4.7 Utility areas
- 5:21-4.8 Right-of-way and cartway
- 5:21-4.9 Street grade and intersections
- 5:21-4.10 Pavement
- 5:21-4.11 Street and site lighting (Reserved)
- 5:21-4.12 Underground wiring
- 5:21-4.13 Street and traffic signs
- 5:21-4.14 Parking: number of spaces
- 5:21-4.15 Parking space size
- 5:21-4.16 Parking areas
- 5:21-4.17 Curb construction standards
- 5:21-4.18 Sidewalks and bikeways construction standards
- 5:21-4.19 Street grade, intersections, pavement, and lighting construction standards
- 5:21-4.20 Curves

SUBCHAPTER 5. WATER SUPPLY

- 5:21-5.1 Water supply system
- 5:21-5.2 Capacity
- 5:21-5.3 System design and placement
- 5:21-5.4 Fire hydrants

APPENDIX. HARDY-CROSS METHOD**SUBCHAPTER 6. SANITARY SEWERS**

- 5:21-6.1 Sanitary sewer system
- 5:21-6.2 System planning, design, and placement

SUBCHAPTER 7. STORMWATER MANAGEMENT

- 5:21-7.1 Stormwater management: general system strategy
- 5:21-7.2 Runoff estimation techniques
- 5:21-7.3 Runoff collection system design
- 5:21-7.4 Inlets, catch basins, manholes and outlets
- 5:21-7.5 Detention basins and other stormwater facilities
- 5:21-7.6 Stormwater management: water quality

APPENDIX. CORRUGATED METAL PIPE STANDARDS**SUBCHAPTER 8. REFERENCED STANDARDS**

- 5:21-8.1 Referenced standards

SUBCHAPTER 1. GENERAL GUIDELINES**5:21-1.1 Title; division into subchapters**

(a) These rules shall be known as the "New Jersey Residential Site Improvement Standards" and are referred to herein as "the rules."

(b) This chapter consists of the following subchapters:

1. "General Provisions," which may be cited throughout the rules as N.J.A.C. 5:21-1 and when referred to in subchapter 1 of this chapter, may be cited as "this subchapter."

2. "Application and Review Procedures," which may be cited throughout the rules as N.J.A.C. 5:21-2 and when referred to in subchapter 2 of this chapter, may be referred to as "this subchapter."

3. "Exceptions, Waivers, and Special Area Standards," which may be cited throughout these rules as N.J.A.C. 5:21-3 and when referred to in subchapter 3 of this chapter, may be referred to as "this subchapter."

4. "Streets and Parking," which may be cited throughout these rules as N.J.A.C. 5:21-4 and when referred to in subchapter 4 of this chapter, may be referred to as "this subchapter."

5. "Water Supply," which may be cited throughout these rules as N.J.A.C. 5:21-5 and when referred to in subchapter 5 of this chapter, may be referred to as "this subchapter."

6. "Sanitary Sewers," which may be cited throughout these rules as N.J.A.C. 5:21-6 and when referred to in subchapter 6 of this chapter, may be referred to as "this subchapter."

7. "Stormwater Management," which may be cited throughout these rules as N.J.A.C. 5:21-7 and when referred to in subchapter 7 of this chapter, may be referred to as "this subchapter."

8. "Referenced Standards," which may be cited throughout these rules as N.J.A.C. 5:21-8 and referred to in subchapter 8 of this chapter, may be referred to as "this subchapter."

5:21-1.2 Authority

These rules are promulgated by the Commissioner of the Department of Community Affairs pursuant to the authority of P.L. 1993, c.32 (N.J.S.A. 40:55D-40.1 et seq.)

5:21-1.3 Intent and purpose

(a) It is the intent and purpose of these rules:

1. To reduce the multiplicity of standards for residential subdivisions and site improvements which currently exists in this State in order to eliminate unnecessary increases in the cost of housing where there are noncommensurate gains in the protection of public health and safety;

2. To avoid unnecessary cost in the construction process, and to provide site improvement standards that are both sound and cost effective;

3. To ensure predictability in the site improvement standards applicable to residential construction;

4. To provide for development reviews of residential projects that are based, to the greatest extent possible, upon sound objective site improvement standards rather than upon discretionary design standards;

5. To streamline the development approval process and improve the efficiency of the application process by providing a uniform set of technical site improvement standards for land development;

6. To provide the widest possible range of design freedom and promote diversity through performance-oriented site improvement standards; and

7. To separate the policy-making aspects of development review from the making of technical determinations.

5:21-1.4 Definitions and abbreviations

The following words, terms, and abbreviations, when used in this chapter, shall have the following meanings, unless the context clearly indicated otherwise. Where a word or term is defined in this chapter and the Municipal Land Use Law (N.J.S.A. 40:55D-1 et seq.), then the definition of that word or term found in the Municipal Land Use Law shall govern. Words and terms found in the Municipal Land Use Law, and defined here for convenience, have been designated by the use of "(MLUL)" following their meaning.

"AASHTO" means American Association of State Highway and Transportation Officials.

"ABS" means acrylonitrile-butadiene-styrene.

"ACI" means American Concrete Institute.

"Administrative Officer" means the clerk of the municipality, unless a different municipal official or officials are designated by ordinance or statute. (MLUL).

"ADT" (see average daily traffic.)

"Aggressive Soils" means soils which may be corrosive to metallic pipe or tubing.

"Aisle" means the traveled way by which cars enter and depart parking spaces.

"Alley" means a service road that provides a secondary means of access to lots.

"ANSI" means American National Standards Institute.

"Applicant" means a developer submitting an application for development. (MLUL).

"Application For Development" means the application form and all accompanying documents required by ordinance for approval of a subdivision plat, site plan, planned development, conditional use, zoning variance, or direction of the issuance of a permit pursuant to the Municipal Land Use Law. (MLUL).

“Approving Authority” means the planning board of the municipality, unless a different agency is designated by ordinance when acting pursuant to the Municipal Land Use Law. (MLUL).

“Arterial Street” means a higher-order, interregional road in the street hierarchy; conveys traffic between centers; should be excluded from residential areas. (See “street hierarchy”.)

“ASCE” means American Society of Civil Engineers.

“ASTM” means American Society for Testing and Materials.

“Average Daily Traffic” means the number of vehicles per day that pass over a given point.

“AWWA” means American Water Works Association.

“Barrier Curb” means a curb specially designed to separate opposing traffic on roads or highways.

“Berm” means a mound of soil, either natural or constructed, used for one or more of the following purposes: screen, buffer, separator, landscape feature, noise attenuator, dam, or stormwater control.

“Bicycle-Compatible Roadway” means a road designed to accommodate the shared use of the roadway by bicycles and motor vehicles.

“Bicycle Lane (bike lane)” means a portion of a roadway which has been designated by striping, signing, and pavement markings for the preferential or exclusive use of bicyclists.

“Bicycle Path (bike path)” means a bikeway physically separated from motorized vehicular traffic by an open space or barrier, and either within the highway right-of-way or within an independent right-of-way or easement.

“Bikeway” means any road, path, or way which in some manner is specifically designated as being open to bicycle travel, regardless of whether such facilities are designated for the exclusive use of bicycles or are to be shared with other transportation modes.

“Blow Off” means a device to allow the escape of air, fluid, or sediments from a pipe within which fluid is flowing under pressure greater than atmospheric pressure.

“Board of Adjustment” means the zoning board of adjustment established pursuant to N.J.S.A. 40:55D-69. (MLUL).

“CAFRA” means Coastal Area Facility Review Act.

“Caliper” means the diameter of a tree trunk measured in inches, four feet above ground level.

“Capped System” means a completed water supply and/or sewerage system put in place for future use (contingent upon expansion), rather than to meet immediate development needs.

“Carbonate Rock” means a rock consisting chiefly of calcium and magnesium carbonates.

“Cartway” means the actual road surface area from curbline to curbline which may include travel lanes, parking lanes, and deceleration and acceleration lanes. Where there are no curbs, the cartway is that portion between the edges of the paved, or hard surface, width.

“Centerline Offset of Adjacent Intersections” means the gap between the centerline of roads intersecting a common road, as measured along the centerline of the intersected road.

“Channel” means any natural or man-made waterway or course through which to convey the constant or intermittent flow of water.

“Channelization” means the straightening and deepening of channels, and/or the surfacing thereof, to permit water to move more rapidly or to redirect the flow of surface water.

“Cluster Development” (see “residential cluster”.)

“Common Lateral” means a lateral serving more than one dwelling unit.

“Common Open Space” means an open space area within or related to a site designated as a development, and designed and intended for the use or enjoyment of residents and owners of the development. Common open space may contain such complementary structures and improvements as are necessary and appropriate for the use or enjoyment of residents and owners of the development. (MLUL).

“Concept Plan” means a preliminary presentation and attendant documentation of a proposed subdivision or site plan of sufficient accuracy to be used for the purpose of discussion and classification.

“Corporation Stop” (also known as “corporation cock”) means a valve which is placed in a building’s water or gas service pipe near its junction with the public water or gas main.

“Cul-de-Sac” means a street with a single means of ingress and egress and having a turnaround, the design of which may vary. (See “street hierarchy”.)

“Culvert” means a closed or open conduit designed for the purpose of conveying an open channel watercourse under a road, highway, pedestrian walk, railroad embankment, or other type of overhead structure.

“Curb” means a stone, concrete, or other improved boundary marking the edge of the roadway or paved area.

“Cushions” means supportive or protective bedding materials placed underneath piping.

“Dams and Embankments” means artificial dikes, levees, or other barriers, with appurtenances, for the purpose of impounding or retaining water.

“Days” means calendar days. (MLUL).

“Dedication” means an appropriation of land to some public use made by the owner and accepted for such use by or on behalf of the public.

“Density” means the permitted number of dwelling units per gross area of land to be developed. (MLUL).

“Design Engineer” means a person professionally qualified and duly licensed to perform engineering services that may include, but not necessarily be limited to, development of project requirements, creation and development of project design, and preparation of drawings and specifications.

“Design Flood” means the magnitude of a flooding event that a facility is designed to accommodate. This event can also be used as the basis of a water surface elevation, or the delineation of a floodway and flood hazard area.

“Design Professional” means a person professionally qualified and duly licensed to perform engineering or other professional design services that may include, but not necessarily be limited to, development of project requirements, creation and development of project design, and preparation of drawings and specifications.

“Design Standards” means standards that set forth specific improvement requirements.

“Detention Basin” means a stormwater management basin or alternative structure designed to temporarily detain stormwater runoff.

“Developer” means the legal or beneficial owner or owners of a lot or of any land proposed to be included in a proposed development, including the holder of an option or contract to purchase, or other person having an enforceable proprietary interest in such land. (MLUL).

“Development” means the division of a parcel of land into two or more parcels; the construction, reconstruction, conversion, structural alteration, relocation, or enlargement of any building or other structure, or of any mining excavation or landfill; and any use or change in the use of any building or other structure, or land, or extension of use of land, for which permission may be required per the Municipal Land Use Law. (MLUL).

“Development, Conventional” means development other than planned development. (MLUL).

“Development Plan, General” means a comprehensive plan for the development of a planned development, as provided in the Municipal Land Use Law. (MLUL).

“Development, Planned” means unit development, planned unit residential development, residential cluster, planned commercial development, or planned industrial development. (MLUL).

“Development, Planned Unit” means an area with a specified minimum contiguous acreage of 10 acres or more to be developed as a single entity according to a plan, containing one or more residential clusters or planned unit residential developments and one or more public, quasi-public, commercial, or industrial areas in such ranges of ratios of nonresidential uses to residential uses as shall be specified in the zoning ordinance. (MLUL).

“Development, Planned Unit Residential” means an area with a specified minimum contiguous acreage of five acres or more to be developed as a single entity according to a plan, containing one or more residential clusters, which may include appropriate commercial or public or quasi-public uses, all primarily for the benefit of the residential development. (MLUL).

“Development Regulation” means a zoning ordinance, subdivision ordinance, site plan ordinance, official map ordinance, or other municipal regulation of the use and development of land, or amendment thereto adopted and filed pursuant to the Municipal Land Use Law. (MLUL).

“Divided Street” means a street having an island or other barrier separating opposing moving lanes.

“Dolomite” means a carbonate rock that contains more than 15 percent magnesium carbonate.

“Drainage” means the removal of surface water or groundwater from land by drains, grading, or other means and includes control of runoff during and after construction or development to minimize erosion and sedimentation, to assure the adequacy of existing and proposed culverts and bridges, to induce water recharge into the ground where practical, to lessen nonpoint pollution, to maintain the integrity of stream channels for their biological functions as well as for drainage, and the means necessary for water supply preservation or prevention or alleviation of flooding. (MLUL).

“Drainage Facility” means any component of the drainage system.

“Drainage System” means natural and man-made components that contain, convey, absorb, store, treat, or dispose of surface water runoff or groundwater.

“Driveway” means a defined paved or unpaved surface providing vehicular access to a street. A driveway is not a road, street, boulevard, highway, or parkway.

“Drop Manhole” means an inspection chamber used at changes in horizontal and/or vertical directions for underground utility conduits where the incoming conduit is two feet or more above the elevation of the discharge conduit.

“Drop Pipe” means a vertical pipe used to convey sewage from a higher to a lower elevation.

“Dry Lines” (see “capped system”).

“Easement” means a right to use the land of another for a specific purpose.

“Edge Definition” means as it pertains to streets, a way of identifying the traveled way from the nontraveled way, such as by the use of railings, bollards, wheel stops, or edge plantings.

“Emergency Spillway” means a supplemental spillway whose function is to pass the design storm flows in the event the principal spillway fails to operate as designed or is blocked.

“Erosion” means the detachment and movement of soil or rock fragments by water, wind, ice, and gravity. (MLUL).

“Escrow” means a deed, bond, money, or piece of property delivered to a third person, to be delivered by him to the grantee only upon fulfillment of a condition.

“Exempt Subdivision” (see “subdivision”).

“Fence” means an artificially-constructed barrier of wood, masonry, stone, wire, metal, or any other manufactured material or combination of materials.

“Final Approval” means the official action of the planning board taken on a preliminary approved major subdivision or site plan after all conditions, engineering plans, and other requirements have been completed or fulfilled and the required improvements have been installed, or guarantees properly posted for their completion, or approval conditioned upon the posting of such guarantees. (MLUL).

“Final Plat” means the final map of all, or a portion, of a subdivision which is presented for final approval.

“Flushing” means the cleaning out of debris and sediment from pipes by force of moving liquid, usually water.

“Governing Body” means the chief legislative body of the municipality. In municipalities having a board of public works, “governing body” means such a board. (MLUL).

“Grade” means the inclination of a sloping surface, usually expressed in percentage terms.

“Graded Area” means as it pertains to streets, land adjacent and parallel to the cartway within the right-of-way, which must be flattened or leveled to the same width and cross-slope as a sidewalk, if a sidewalk had been required at that location.

“Granite Block Curb” (also known as “Belgian block curb”) means a curb constructed of rectangular-shaped stone or granite blocks, usually placed vertically in a concrete foundation.

“Gutter” means a shallow channel, usually set along a curb or the pavement edge of a road, for purposes of catching and carrying off runoff water.

“Historic District” means one or more historic sites and intervening or surrounding property significantly affecting, or affected by, the quality and character of the historic site or sites. (MLUL).

“Historic Site” means any real property, man-made structure, natural object, or configuration, or any portion or group of the foregoing of historical, archaeological, cultural, scenic, or architectural significance. (MLUL).

“Hydrologic Response” means the properties, distribution, and circulation of water.

“IES” means Illuminating Engineering Society of North America.

“Impervious Surface” means a surface that has been compacted or covered with a layer of material so that it is highly resistant to infiltration by water.

“Impoundment” means a body of water, such as a pond, confined by a dam, dike, floodgate, or other barrier.

“Improved Public Street” means for subdivision purposes or site plan, any street which complies in width and construction with municipal standards.

“Improvement” means any constructed element which becomes part of, is placed upon, or is affixed to real estate.

“Individual Sewage Disposal System” means a septic tank, seepage tile sewage disposal system, or any other approved sewage treatment device serving a single unit.

“Individual Subsurface Sewage Disposal System” means a system for disposal of sanitary sewage into the ground which is designed and constructed to treat sanitary sewage in a manner that will retain most of the settleable solids in a septic tank, and to discharge the liquid effluent to a disposal field. The term “system” is equivalent in meaning.

“Island” means in street design, a raised area, usually curbed, placed to guide traffic and separate lanes, or used for landscaping, signing, or lighting.

“ISO” means Insurance Services Office, Inc.

“ITE” means Institute of Transportation Engineers.

“Land” means real property including improvements and fixtures on, above, or below the surface.

“Laterals, (plumbing/sewer)” means pipes conducting sewage from individual buildings to larger pipes called trunk, or interceptor, sewers that usually are located in street rights-of-way.

“Limestone” means a carbonate sedimentary rock consisting chiefly of calcium carbonate. Limestone is commonly used as a general term for the class of rocks that consist of at least 80 percent calcium or magnesium carbonate.

“Lot” means a designated parcel, tract, or area of land established by a plat, or otherwise as permitted by law, and to be used, developed, or built upon as a unit. (MLUL).

“Main” means in any system of continuous piping, the principal artery of the system to which branches may be connected.

“Maintenance Guarantee” means any security which may be accepted by a municipality for the maintenance of any improvements required by the Municipal Land Use Law, including, but not limited to, surety bonds, letters of credit under the circumstances specified in N.J.S.A. 40:55D-53.3, and cash. (MLUL).

“Manhole” means an inspection chamber located at changes in horizontal and vertical directions for underground utility conduits whose dimensions allow entry, exit, and working room.

“Marble” means a metamorphic rock consisting chiefly of crystallized limestone or dolomite.

“Marginal Access Street” means a service street that runs parallel to a higher-order street which provides access to abutting properties and separation from through traffic. It may be designed as a residential access street or minor collector as anticipated daily traffic dictates.

“Master Plan” means a composite of one or more written or graphic proposals for the development of the municipality, as set forth and adopted by the planning board pursuant to N.J.S.A. 40:55D-28. (MLUL).

“Median” means that portion of a divided highway separating the traveled ways of traffic proceeding in opposite directions.

“Mixed Use” means two or more different uses, one of which is residential.

“MLUL” means Municipal Land Use Law, N.J.S.A. 40:55D-1 et seq.

“Mountable curb” means a low curb with a slope designed to be crossed easily.

“Moving Lane” means any traffic lane where traffic movement is the primary, if not sole, function.

“Mulch” means a layer of wood chips, dry leaves, straw, hay, plastic, or other materials placed on the surface of the soil around plants to retain moisture, prevent weeds from growing, hold the soil in place, and aid plant growth.

“Multifamily development” means a development other than one- or two-family detached dwellings where the dwellings are arranged so that there are more than two units attached, regardless of the presence of lot lines.

“Municipality” means any city, borough, town, township, or village. (MLUL).

“NFPA” means National Fire Protection Association.

“Nonstructural Management Practices” means those controls of stormwater runoff and nonpoint source pollution that are not structural in nature, such as landscaping techniques, source controls, zoning, setbacks, buffers, or clustering.

“Offsite” means located outside the lot lines of the lot in question but within the property (of which the lot is a part) which is the subject of a development application or contiguous portion of a street or right-of-way. (MLUL).

“Off-Street Parking Space” means a storage area for a motor vehicle that is directly accessible to an access aisle and that is not located within a dedicated street right-of-way.

“Offtract” means not located on the property which is the subject of a development application, nor on a contiguous portion of a street or right-of-way. (MLUL).

“Onsite” means located on the lot in question. (MLUL).

“On-Street Parking Space” means a storage area for a motor vehicle that is located within a dedicated street right-of-way.

“Ontract” means located on the property which is the subject of a development application, or on a contiguous portion of a street or right-of-way. (MLUL).

“Open Space” means any parcel or area of land or water essentially unimproved and set aside, dedicated, designated, or reserved for public or private use or enjoyment, or for the use and enjoyment of owners and occupants of land adjoining or neighboring such open space, provided that such areas may be improved with only those buildings, structures, streets, and off-street parking and other improvements that are designed to be incidental to the natural openness of the land. (MLUL).

“Parking Lane” means a lane usually set on the sides of streets, designed to provide on-street parking.

“Parking lot” means a ground-level, generally open area that provides storage for motor vehicles that may provide access to dwelling units and which has aisles that carry traffic with destination or origin in the lot itself.

“Parking Space” means a storage area provided for the parking of a motor vehicle.

“Pavement” means a surface created to facilitate passage of people and/or vehicles, usually constructed of brick, stone, concrete, or asphalt.

“Pedestrian Generator” means a development which will realize high facility usage by persons arriving on foot.

“Percolation Test (Perc Test)” means a test designed to determine the ability of ground to absorb water and used in determining the suitability of a soil for drainage or for the use of a septic system.

“Performance Guarantee” means any security which may be accepted by a municipality including but not limited to surety bonds, letters of credit under the circumstances specified in N.J.S.A. 40:55D-53.5, and cash. (MLUL).

“Pervious Surface” means any surface that permits a significant portion of surface water to be absorbed.

“Planning Board” means the municipal planning board established pursuant to the Municipal Land Use Law. (MLUL).

“Plat” means a map or maps of a subdivision or site plan. (MLUL).

“Potable Water Supply” means water suitable for drinking or cooking purposes.

“Preliminary Approval” means the conferral of certain rights pursuant to N.J.S.A. 40:55D-46, 48, and 49 prior to final approval after specific elements of a development plan have been agreed upon by the planning board and the applicant. (MLUL).

“Preliminary Floor Plans and Elevations” means architectural drawings prepared during early and introductory stages of the design of a project illustrating in a schematic form its

scope, scale, and relationship to its site and immediate environs. (MLUL).

“Preliminary Subdivision Plat” means a map indicating the proposed layout of a development and related information that is submitted for preliminary approval.

“Principal Basin” means a detention or retention basin whose function is controlling or managing the runoff from a particular area or property that is to be developed.

“Public Open Space” means an open space area conveyed or otherwise dedicated to a municipality, municipal agency, board of education, State or county agency, or other public body for recreational or conservation uses. (MLUL).

“PUD” (see “planned unit development”).

“PVC” means Polyvinyl chloride.

“Residential Access Street” means the lowest order, other than rural street type, of residential street (see “street hierarchy”). Provides frontage for access to private lots and carries traffic having destination or origin on the street itself. Designed to carry traffic at slowest speed.

“Residential Cluster” means an area to be developed as a single entity according to a plan containing residential housing units which have a common or public open space area as an appurtenance. (MLUL).

“Residential Density” means the number of dwelling units per gross acre of residential land area including streets, easements, and open space portions of a development. (MLUL).

“Residential Major Collector” means the highest order of residential street (see “street hierarchy”). Conducts and distributes traffic between lower-order residential streets and higher-order streets (arterials and expressways).

“Residential Minor Collector” means middle order of residential streets (see Street Hierarchy). Provides frontage for access to lots, and carries traffic to and from adjoining residential access streets.

“Residential Neighborhood Street” means a type of residential access street conforming to traditional subdivision street design, which provides access to building lots fronting on a street and provides parking on both sides of street. (See “street hierarchy”).

“Resubdivision” means:

1. The further division or relocation of lot lines of any lot or lots within a subdivision previously made and approved or recorded according to law; or
2. The alteration of any streets or the establishment of any new streets within any subdivision previously made and approved or recorded according to law, but does not

include conveyances so as to combine existing lots by deed or other instrument. (MLUL).

“Retaining Wall” means a structure that is designed and constructed to stabilize two generally horizontal surfaces which are vertically displaced.

“Retention Basin” means a stormwater management basin designed to retain some water on a permanent basis.

“Right-Of-Way” means a strip of land occupied or intended to be occupied by a street, crosswalk, railroad, road, electric transmission line, gas pipeline, water main, sanitary or storm sewer main, shade tree, or for another special use.

“Rural” means as it pertains to streets, when density is one dwelling unit per acre or lower, a road primarily serving as access to abutting building lots, which has no on-street parking, and lot-to-street access is designed so vehicles do not back out of lots onto the street. (See “street hierarchy”.)

“SCS” means Soil Conservation Service.

“SDR” means Standard Dimensional Ratio.

“Sedimentation” means the deposition of soil that has been transported from its site of origin by water, ice, wind, gravity, or other natural means as a product of erosion. (MLUL).

“Septic System” means an underground system with a septic tank used for the decomposition of domestic wastes.

“Septic Tank” means a watertight receptacle which receives the discharge of sanitary sewage from a building sewer or part thereof, and is designed and constructed so as to permit settling of settleable solids from the liquid, partial digestion of the organic matter, and discharge of the liquid portion into a disposal field or seepage pit.

“Sewer” means any pipe conduit used to collect and carry away sewage or stormwater runoff from the generating source to treatment plants or receiving streams.

“Shoulder” means the portion of the roadway contiguous with the traveled way for accommodation of stopped vehicles, for emergency use, and for lateral support of base and surface courses.

“Sidewalk” means an improved path for pedestrian use outside the cartway.

“Sight Triangle” means a triangular-shaped portion of land established at street intersections in which nothing is erected, placed, planted, or allowed to grow in such a manner as to limit or obstruct the sight distance of motorists entering or leaving the intersection.

“Site Improvements” means any construction work on, or improvement in connection with, residential development limited to streets, roads, parking facilities, sidewalks, drainage structures, and utilities.

“Site Plan” means a development plan of one or more lots on which is shown:

1. The existing and proposed conditions of the lot including, but not necessarily limited to, topography, vegetation, drainage, flood plains, marshes, and waterways;
2. The location of all existing and proposed buildings, drives, parking spaces, walkways, means of ingress and egress, drainage facilities, utility services, landscaping, structures, signs, lighting, and screening devices; and
3. Any other information that may be reasonably required in order to make an informed determination pursuant to an ordinance requiring review and approval of site plans by the planning board adopted pursuant to N.J.S.A. 40:55D-37 et seq. (MLUL).

“Site Plan, Major” means any site plan not classified as a minor site plan.

“Site Plan, Minor” means a development plan of one or more lots which:

1. Proposes new development within the scope of development specifically permitted by ordinance as a minor site plan;
2. Does not involve planned development, any new street, or extension of any off-tract improvement which is to be prorated pursuant to N.J.S.A. 40:55D-42; and
3. Contains the information reasonably required in order to make an informed determination as to whether the requirements established by ordinance for approval of a minor site plan have been met. (MLUL).

“Sketch Plat” (see “concept plan”.)

“Soil” means the arable layers of unmodified sediments beneath the surface material and above bedrock.

“Soil Cement” means a mixture of portland cement and soil.

“Soil Erosion” means the gradual alteration of soil by crustal movement or by processes of weathering, transportation, and sedimentation.

“Stabilization” means, as it pertains to streets, the ability of a surface to resist deformation from imposed loads. Stabilization can be accomplished by adequate thicknesses of asphalt base and surface course, dense graded aggregates, cement treated soil aggregates, or concrete or precast masonry units set on a base course.

“Stabilized Base Course (Bituminous)” means stabilized base course or asphalt concrete base consisting of soil aggregate and bituminous material uniformly mixed and placed on a previously prepared surface.

“Stabilized Earth” means earth or soil, strengthened usually by the mixing of cement or lime with the original material to achieve increased strength, thereby reducing shrinkage and movement.

“Stabilized Turf” means established, mowable vegetation.

“Stormwater Detention” means a provision for temporary storage of stormwater runoff, and the controlled release of such runoff during and after a flood or storm.

“Stormwater Management Measures” means a broad term for structural and nonstructural control of stormwater runoff and nonpoint pollution.

“Stormwater Retention” means a provision for the permanent storage of a fixed volume of water.

“Street” means any street, avenue, boulevard, road, parkway, viaduct, drive, or other way which is an existing State, county, or municipal roadway, or which is shown upon a plat heretofore approved pursuant to law, or which is approved by official action as provided by the MLUL, or which is shown on a plat duly filed and recorded in the office of the county recording officer prior to the appointment of a planning board and the grant to such board of the power to review plats; and includes the land between the street lines, whether improved or unimproved, and may comprise pavement, shoulders, gutters, curbs, sidewalks, parking areas, and other areas within the street lines. (MLUL).

“Street Hardware” means the mechanical and utility systems within a street right-of-way such as hydrants, manhole covers, traffic lights and signs, utility poles and lines, parking meters, and the like.

“Street Hierarchy” means the conceptual arrangement of streets based upon function. A hierarchical approach to street design classifies streets according to function, from high-traffic arterial roads to streets whose function is residential access.

“Street, Loop” means a street that has its only ingress and egress at two points on the same street.

“Stub Street” means a street which is to be extended when the adjacent property is developed.

“Subdivision” means the division of a lot, tract, or parcel of land into two or more lots, tracts, parcels, or other divisions of land for sale or development. The following shall not be considered subdivisions within the meaning of these rules, if no new streets are created: divisions of land found by the planning board or subdivision committee thereof appointed by the chairman to be for agricultural

purposes, where all resulting parcels are five acres or larger in size; divisions of property by testamentary or intestate provisions; divisions of property upon court order, including but not limited to judgments of foreclosure; consolidation of existing lots by deed or other recorded instrument; and the conveyance of one or more adjoining lots, tracts, or parcels of land owned by the same person or persons, all of which are found and certified by the administrative officer to conform to the requirements of the municipal development regulations, and are shown and designated as separate lots, tracts, or parcels on the tax map or atlas of the municipality. The term “subdivision” shall also include the term “resubdivision.” (MLUL).

“Subdivision, Major” means any subdivision not classified as a minor subdivision. (MLUL).

“Subdivision, Minor” means a subdivision of land for the creation of a number of lots specifically permitted by ordinance as a minor subdivision, provided that such subdivision does not involve a planned development, any new street, or the extension of any off-tract improvement, the cost of which is to be prorated pursuant to N.J.S.A. 40:55D-42. (MLUL).

“Subgrade” means the prepared surface upon which pavements and shoulders are constructed.

“Surface Course” means the placement of the asphalt concrete material on a previously prepared base course.

“Swale” means a low lying or depressed land area commonly wet or moist, which can function as an intermittent drainage way.

“Topsoil” means:

1. The natural, undisturbed surface layer of soil having more organic matter than subsequent layers, a pH of 5.0 to 7.5, and suitable for satisfactory growth and maintenance of permanent, locally-adapted vegetation.

2. Where the original surface layer has been removed, the reapplication of soil material used to cover an area so as to improve soil conditions for establishment and maintenance of adapted vegetation. The reapplied material must be friable, loamy soil reasonably free of debris, objectionable weeds, and stones; have a natural pH of 5.0 to 7.5; have an organic matter content greater than 2.00 percent; and contain no toxic substances which may be harmful to plant growth.

“Traveled Way” means the portion of a cartway used for vehicular travel.

“Trip” means a single or one-way vehicle movement to or from a property or study area.

“ULI” means Urban Land Institute.

“USCGS (also USC&G and USC&GS)” means United States Coast and Geodetic Survey.

“Utility Area” means a flexible space within the right-of-way designated for the installation of utility lines and facilities.

“Utility Authority” means any “sewerage authority” as defined in N.J.S.A.40:14A-3 or any “municipal authority” as defined in N.J.S.A. 40:14B-3.

“Variance” means permission to depart from the literal requirements of a zoning ordinance, pursuant to N.J.S.A. 40:55D-40b., 70c., and 70d. (MLUL).

“Wet Pond” (see “retention basin”).

Administrative correction.

See: 29 N.J.R. 1296(a).

Amended by R.1999 d.374, effective November 1, 1999 (operative May 1, 2000).

See: 31 N.J.R. 477(a), 31 N.J.R. 3259(a).

Substituted “Where” for “There” at the beginning of the second sentence in the introductory paragraph; and in “Mountable curb”, deleted “flat” preceding “slope”.

Amended by R.2002 d.399, effective December 16, 2002.

See: 34 N.J.R. 2615(a), 34 N.J.R. 4412(a).

Added “Multifamily development” and “Parking lot”; deleted “Parking Loop”.

5:21-1.5 Scope and applicability

(a) These rules shall govern any site improvements carried out or intended to be carried out or required to be carried out in connection with any application for residential subdivision, site plan approval, or variance before any planning board or zoning board of adjustment created pursuant to the Municipal Land Use Law (N.J.S.A. 40:55D-1 et seq.); or in connection with any other residential development approval required or issued by any municipality or agency or instrumentality thereof.

(b) Except as is otherwise specifically provided, these rules shall control all matters concerning the construction, alteration, addition, repair, removal, demolition, maintenance, and use of any site improvements constructed by a developer in connection with residential development. Except as otherwise required by rules or other permit requirements of the Department of Environmental Protection regarding storm water management, the rules are to be interpreted as the minimum required to ensure public health and safety, and the maximum that may be required in connection with residential development.

(c) These rules shall apply to all site improvement work and appurtenant construction including streets, roads, parking facilities, sidewalks, drainage structures, grading, and utilities which are undertaken by a developer in connection with residential development or use.

1. Where both residential and commercial development are planned in a mixed-use development, these rules shall apply to the residential part or parts of such development where such residential part or parts are discrete and separate from planned commercial parts as evidenced by, for example, separate building(s), separate parking, and separate access features.

2. These rules shall apply to all utilities created by or deriving their authority from municipal ordinance to operate within a given jurisdiction.

3. Choice among options contained in these rules shall be the applicant’s unless otherwise specified in these rules.

(d) Nothing contained in these rules shall be construed to limit the powers of any municipality to establish and enforce any requirement concerning:

1. Layout, arrangement, and location of improvements, shade trees, landscaping, or reservation of areas for public use, pursuant to N.J.S.A. 40:55D-38;

2. Preservation of existing natural resources; arrangement of physical elements for safe and efficient vehicular and pedestrian circulation, by, for example, traffic calming measures as described in “Residential Street Design and Traffic Control,” by W. S. Homburger et al. (Institute of Transportation Engineers, 1989), parking, and loading; screening, landscaping, and location of structures; or conservation of energy and use of renewable resources; pursuant to N.J.S.A. 40:55D-41; or

3. Use, bulk, height, number of stories, orientation, and size of buildings and other structures; the percentage of lot or development area that may be occupied by structures, lot sizes and dimensions, floor area ratios, or other measures to control development intensity; or the provision of adequate light and air pursuant to N.J.S.A. 40:55D-65.

(e) The provisions of these rules shall not preempt or in any way affect the exercise of any authority by the State or any county government with respect to site improvements conferred by any State law or any rule promulgated thereunder. Nor shall these rules be in any way interpreted to modify or otherwise affect rules promulgated pursuant to the Pinelands Commission Act, N.J.S.A. 13:18A-1 et seq. (N.J.A.C. 7:50). It is the intent of these rules to be consistent with all other applicable laws, rules and regulations. Where these rules and any other State or county laws, rules or regulations establish differing requirements, then the requirements of these rules shall govern, except where any such differing requirement is more restrictive.

(f) These rules shall not apply to driveways on private property held in fee-simple as individual residential lots outside of the public right-of-way, including common driveways established by easements shared by more than one but not more than four dwelling units on private property.

(g) These rules are intended to ensure the public health, safety, and welfare insofar as they are affected by site improvement work, and shall be so construed.

Administrative correction.

See: 29 N.J.R. 1296(a).

Amended by R.1998 d.399, effective August 3, 1998.

See: 30 N.J.R. 1660(a), 30 N.J.R. 2861(a).

In (b), inserted "Except as otherwise required by rules or other permit requirements of the Department of Environmental Protection regarding storm water management, the" at the beginning of the second sentence.

Amended by R.2000 d.480, effective December 4, 2000 (operative June 3, 2001).

See: 32 N.J.R. 2670(b), 32 N.J.R. 4277(a).

In (f), inserted "but not more than four".

Proposed Code Change:

Supporting Statement (Reason for change should include an “authoritative source” and cost analysis where appropriate.):

Changes to the technical requirements in the standards must be based on recommended site improvement standards that are published by an academic or professional institution or organization, similar to those used in the original Rutgers Model Subdivision and Site Plan Ordinance.

New Rule, R.2001 d.352, effective October 1, 2001.
 See: 33 N.J.R. 1237(a), 33 N.J.R. 3427(a).

SUBCHAPTER 4. STREETS AND PARKING

5:21-4.1 Street hierarchy

(a) Streets shall be classified in a hierarchy with design tailored to function. The street hierarchy definitions contained within this section are applicable only to local residential streets and are not to be considered related to the U.S. Department of Transportation, Federal Highway Administration's Functional Classification of Highways.

(b) The street hierarchy system shall be defined by road function and average daily traffic (ADT), calculated by trip generation rates from the current edition of "Trip Generation" by the Institute of Transportation Engineers, as indicated in Table 4.1 below. Trip generation rates from other sources may be used if the applicant demonstrates to the appropriate approving authority that these sources better reflect local conditions. In addition, the applicant shall investigate the opportunities for, and availability of, transit facilities and, if appropriate, consider their impact(s) on motor vehicle traffic trip generation rates per dwelling unit.

(c) Each residential street shall be classified and designed to meet the standards for one of the street types defined in Table 4.2 below. The entire length of the street need not be designed based on the highest ADT where the ADT varies along the street's length. However, each street segment between intersections shall be designed based on the highest ADT served in that segment.

(d) The municipality and the developer shall determine the highest order street required to be used in a given residential development, considering all of the following:

1. The size of the development (number and type of units). For example, using size to determine the highest order of street required, a development of up to 150 single-family detached units would not require any minor collectors or streets of a higher order;
2. The actual or potential development of adjacent sites (whether there is likely to be traffic passing through from neighboring developments). A "potential" development means a development having approvals granted, applications pending, or undergoing preliminary review; and
3. The streets proposed for that area, if any, as contained in the municipal master plan.

**TABLE 4.1
 AVERAGE DAILY MOTOR VEHICLE
 TRAFFIC TRIP GENERATION
 PER DWELLING UNIT¹**

<u>Land use²</u>	<u>Peak rate</u>
Single-family detached housing	10.1

<u>Land use²</u>	<u>Peak rate</u>
Townhouse	5.9
Low-rise apartment	7.2
Mid-rise apartment	5.5
High-rise apartment	5.0
Mobile home park	5.0
Retirement community	2.8
Recreational homes (owner occupied)	3.2

Notes:

¹ The trip generation rates listed are guidelines only. The actual use of trip generation rates is derived by the use of regression analysis and should be computed only by professionals proficient in the use of the ITE Trip Generation manual. The "Land Use" definitions are based on the ITE manual with slight modifications to address inconsistencies contained within the ITE manual.

² For two-family dwellings (duplexes), apply the values for single-family dwellings to each unit.

Source: Institute of Transportation Engineers, Trip Generation (Washington, D.C.: ITE, 1982), 3rd Edition. The table was updated with data from the 6th Edition of the manual published by ITE in 1997. The peak ADT rates take into consideration Saturday and Sunday rates, as well as weekday rates.

DEFINITIONS

<u>Land use</u>	<u>Definition</u>
Single-family detached housing	Any single-family detached home on an individual lot.
Townhouse	Attached multiple-family dwelling units where the only separation between units is vertical.
Apartment	A dwelling unit located within the same building with at least three other dwelling units.
Low-rise apartment	Apartments in buildings that have one or two levels (floors).
Mid-rise apartment	Apartments in buildings that have more than two levels (floors) and less than ten levels.
High-rise apartment	Apartments in buildings with ten or more levels (floors).
Mobile home park	Generally trailers shipped, sited and installed on permanent foundations and in areas that typically have community facilities, such as recreation rooms, swimming pools, and laundry facilities.
Retirement community	Residential units similar to apartments and condominiums usually restricted to adults or senior citizens, and located in self-contained villages. Special services such as medical, dining, and retail facilities may be available.

<u>Land use</u> Recreational home	<u>Definition</u> Dwellings usually located in a resort containing local services and complete recreational facilities. These are often second homes used by the owner or rented on a seasonal basis.
--------------------------------------	--

TABLE 4.2
RESIDENTIAL STREET HIERARCHY DEFINITIONS

<u>Street type</u>	<u>Description</u>	<u>Average daily traffic (maximum)</u>
Residential Access [‡]	<p>Lowest order, other than rural street type, of residential streets Provides frontage for access to lots and carries traffic with destination or origin on the street itself. Designed to carry the least amount of traffic at the lowest speed. All, or the maximum number of housing units, shall front on this class of street.</p> <p>[†] Residential access streets of “loop” configuration, that is, two ways out, should be designed so no section conveys an ADT greater than 1500. Each half of a loop street may be classified as a single residential access street, but the total traffic volume generated on the loop street should not exceed 1500 ADT, nor should it exceed 750 ADT at any point of traffic concentration.</p>	1,500 [†]
Residential Neighborhood [‡]	<p>A type of residential access street conforming to traditional subdivision street design, and providing access to building lots fronting on a street and parking on both sides of street.</p> <p>[‡] Applicant may choose either the RESIDENTIAL ACCESS or the RESIDENTIAL NEIGHBORHOOD street type for new streets. See section 4.8(b) for specific right-of-way and cartway width requirements for new streets that are a continuation of an existing street.</p>	
Minor Collector	<p>Middle order of residential street. Provides frontage for access to lots and carries traffic of adjoining residential access streets. Designed to carry somewhat higher traffic volumes than lower-order streets such as rural and residential access streets, with traffic limited to motorists having origin or destination within the immediate neighborhood. Is not intended to carry regional traffic.</p> <p>Each half of a loop-configured minor collector may be classified as a single minor collector street, but the total traffic volume conveyed on the loop should not exceed 3,500 ADT, nor should it exceed 1750 ADT at any point of traffic concentration.</p>	3,500
Major Collector	<p>Highest order of residential streets. Conducts and distributes traffic between lower-order residential streets and higher-order streets—arterials and expressways. Carries the largest volume of traffic at higher speeds. Function is to promote free traffic flow; therefore, parking should be prohibited and direct access to homes from this level of street should be avoided. Collectors should be designed so they cannot be used as shortcuts by non-neighborhood traffic.</p>	7,500
<u>Special Purpose Streets</u>		
Rural	<p>A rural street is a street that serves dwellings on lots that are one acre or greater, AND primarily serves as access to abutting building lots, AND has no on-street parking, AND has lot-to-street access designed so vehicles do not back out of lots onto the street. Rural streets shall only connect to rural streets, rural residential lanes, or mixed-use collectors. However, a rural street shall not connect two mixed-use collectors.</p>	500
Rural residential lane	<p>A rural residential lane is a street that serves dwellings on lots that are two acres or greater, AND primarily serves as access to abutting building lots, AND has no on-street parking, AND has lot-to-street access designed so vehicles do not have to back out of lots onto the street. Rural residential lanes shall only connect to rural streets, rural residential lanes, or mixed-use collectors. However, a rural residential lane shall not connect two mixed-use collectors.</p>	200

<u>Street type</u>	<u>Description</u>	<u>Average daily traffic (maximum)</u>
Alley	A service road that provides a secondary means of access to lots. On same level as residential access street, but different standards apply. No parking shall be permitted; alleys should be designed to discourage through traffic. ADT level shall not exceed that of a residential access street.	500
Cul-de-sac ¹	A street with a single means of ingress and egress and having a turnaround, the design of which may vary. A divided-type entrance roadway to at least the first cross street, with median of sufficient width to ensure freedom of continued emergency access by lanes on one side, shall not be considered part of a cul-de-sac. Parking lots with a single means of ingress and egress shall not be included within the definition of cul-de-sac.	250
Marginal access street	A service street that runs parallel to a higher-order street and provides access to abutting properties and separation from through traffic. May be designed as residential access street or minor collector, according to anticipated daily traffic.	1,500 (residential access total) 3,500 (minor collector total)
Divided street	Municipalities may require streets to be divided to provide alternate emergency access, protect the environment, or avoid grade changes. Design standards should be applied to the combined dimensions of the two street segments, as required by the street class.	
Multifamily access cul-de-sac	A street with a single means of ingress and egress, which serves multifamily development, that provides a means for vehicles to turn around.	1,000
Multifamily court	A street with a single means of ingress and egress, which serves multifamily development, that does not provide a means for vehicles to turn around. The length of multifamily courts is limited to 300 feet.	Note ²

Notes:

¹ Streets serving multifamily developments with a single means of ingress and egress shall be classified as multifamily access cul-de-sacs.

² There is no ADT limit for multifamily courts specified because the length of the court will effectively limit the ADT to acceptable levels.

Administrative correction.
 See: 29 N.J.R. 1296(a).
 Amended by R.1999 d.374, effective November 1, 1999 (operative May 1, 2000).
 See: 31 N.J.R. 477(a), 31 N.J.R. 3259(a).
 In (c), added a second sentence; and in Table 4.2, added a third sentence in the Cul-de-sac Description, and substituted a reference to non-parallel parking for a reference to perpendicular parking in the Parking Loop Description.
 Administrative correction.
 See: 32 N.J.R. 684(b).
 Amended by R.2000 d.480, effective December 4, 2000 (operative June 3, 2001).
 See: 32 N.J.R. 2670(b), 32 N.J.R. 4277(a).
 Rewrote Table 4.1 and in Table 4.2, rewrote the description of "Rural residential lane".
 Amended by R.2002 d.399, effective December 16, 2002.
 See: 34 N.J.R. 2615(a), 34 N.J.R. 4412(a).
 In Table 4.1, inserted "Trip General" preceding "manual" in the second sentence of footnote 1, and added footnote 2; rewrote Table 4.2.

5:21-4.2 Cartway width

(a) Cartway width for each street classification shall be determined by parking and curbing requirements that are based on intensity of development.

(b) Intensity of development shall be based on dwelling units per gross acre as follows:

<u>Intensity</u>	<u>Dwelling Units per Gross Acre[†]</u>
Low	Less than or equal to 4
Medium	More than 4 and less than or equal to 8
High	More than 8

Note: [†]In determining the intensity of development, the gross acreage shall not include dedicated common open space or other such areas restricted from future development.

(c) Cartway widths for each street classification are as shown in Table 4.3 below.

(d) Cartway width also shall consider possible limitations imposed by sight distances, climate, terrain, and maintenance needs.

(e) Municipalities may require additional cartway width for major or minor collectors which are part of a designated bike route as indicated in the bicycle circulation part of the municipal master plan to make them consistent with the AASHTO guidelines for bicycle-compatible streets.

TABLE 4.3

CARTWAY AND RIGHT-OF-WAY WIDTHS

Street type ^a	Total avg daily traffic 1,500† † (loop—750 each half)	Traveled way	No. of parking lanes ^b	Parking lane width	Cartway width	Curb or shoulder ^h	Sidewalk or graded area ^j	Right-of-way width
Residential access								
a. Parallel parking								
Low intensity		20 ft	1	8 ft	28 ft	None	1 SW GA	50 ft
Medium intensity		20 ft	1	8 ft	28 ft	Curb	2 SW	50 ft
High intensity (on-street parking)		20 ft	1	8 ft	28 ft	Curb	2 SW	50 ft
b. Nonparallel parking (all intensities)								
One-side parking		24 ft	1	18 ft		Curb	2 SW ⁿ	54 ft
Two-side parking		24 ft	2	36 ft		Curb	2 SW ⁿ	72 ft
c. No parking								
High intensity (off-street parking)		20 ft	0	0 ft	20 ft	Curb	2 SW	50 ft
Neighborhood (all intensities)	1,500	14 ft	2	16 ft	30 ft ^c	curb	2 SW	50 ft
Minor Collector ^l	3,500							
Low intensity ^d with no parking		20 ft	0	0 ft	20 ft	none	1 SW 1GA	50 ft
Low with one parking lane		20 ft	1	8 ft	28 ft	curb	1 SW 1 GA	50 ft
Medium and High intensity								
With one parking lane		20 ft	1	8 ft	28 ft	curb	2 SW	50 ft
With two parking lanes		20 ft	2	16 ft	36 ft	curb	2 SW	60 ft
With off-street parking		22 ft	0	0 ft	22 ft	curb or shoulder	2 SW	50 ft
Major Collector ^l	7,500							
Low intensity		24 ft	0	0 ft	24 ft	none	2 SW	50 ft
Medium								50 ft if curb, 54 ft if shoulder
and High		24 ft	0	0 ft	24 ft	curb or shoulder	2 SW	
Multifamily access cul-de-sac ^m	1,000							
Multifamily court ^o	Note ^p							
Special Purpose Streets								
Rural street ^k	500	20 ft	0	0 ft	20 ft	none	2 GA	40 ft
Rural lane ^k	200	18 ft	0	0 ft	18 ft	none	2 GA	40 ft
Alley (one way)					9 ft			11 ft
Alley (two way)		18 ft	0	0 ft	18 ft	none	2 GA	22 ft
Cul-de-sac (stem) ^e	250							
Marginal access street ^f								
Divided street ^g								

NOTES:

^aSee Table 4.2 for definitions of street hierarchy and N.J.A.C. 5:21-4.2 for definitions of low, medium, and high intensity of development.

^bParking lane refers to parallel parking, except in the case of residential access streets with nonparallel parking, which have perpendicular parking.

^cThe 30 foot cartway would accommodate two eight foot parking lanes and one 14 foot moving lane.

^d20 foot minor collector cartways are permitted only when there is no direct building lot access to or from the street in question.

^eCartway widths of cul-de-sac stems and right-of-way requirements should conform to the applicable street type. Right-of-ways for cul-de-sac stems shall extend a minimum of eight feet beyond the cartway. Cul-de-sacs shall provide for a cartway turning radius of 40 feet and a right-of-way line eight feet beyond the edge of the cartway.

^fCartway and right-of-way widths of marginal access streets and right-of-way requirements should conform to standards of either residential access or minor collector streets, as dictated by average daily traffic. If the classification is a minor collector requiring a 36 foot cartway, cartway width may be reduced to 28 feet, since frontage is restricted to one side of the street.

^gCartway widths of divided streets should conform to standards of street classification, as dictated by anticipated average daily traffic, and be applied as aggregate dimensions of two street segments. Divided streets shall be provided with cut-throughs at a maximum of 1,200 foot intervals.

^hSee N.J.A.C. 5:21-4.3(c) for additional requirements.

ⁱRight-of-way width applies only to streets proposed for dedication as shown on approved plans.

^jSee N.J.A.C. 5:21-4.5(b) for additional requirements.

^kRural streets and rural lanes are permitted only within developments which do not exceed an average daily traffic count of 500 and 200, respectively.

^lMunicipalities may require additional cartway width for major or minor collectors which are part of a designated bicycle route as indicated in the circulation part of the municipal master plan to make them consistent with the AASHTO guidelines for bicycle-compatible streets.

^mCartway and right-of-way widths of multifamily cul-de-sac stems should conform to the applicable residential access street type. Cul-de-sacs shall provide for a cartway turning radius of 40 feet or other suitable means for vehicles to turn around, such as hammerheads. Where not located on private property, a right-of-way line eight feet beyond the edge of the cartway shall be provided.

ⁿSidewalks provided for streets with nonparallel parking shall be placed in accordance with N.J.A.C. 5:21-4.5(e).

^oCartway and right-of-way widths for multifamily courts shall comply with the design criteria for residential access streets, based on the parking configuration. Multifamily courts need not be provided with a means for turning around; however, their length shall not exceed 300 feet.

^pThere is no ADT limit for multifamily courts; however, the length of a multifamily court is limited to 300 feet.

Administrative correction.

See: 29 N.J.R. 1296(a).

Amended by R.1999 d.374, effective November 1, 1999 (operative May 1, 2000).

See: 31 N.J.R. 477(a), 31 N.J.R. 3259(a).

In Table 4.3, combined Medium and High Intensity Street Types, changed Parking Loop Right-of-Way Widths, rewrote Note e, added "as shown on approved plans" at the end of Note i, and added Note l. Amended by R.2000 d.480, effective December 4, 2000 (operative June 3, 2001).

See: 32 N.J.R. 2670(b), 32 N.J.R. 4277(a).

In (b), substituted "8" for "15" under Dwelling Units per Gross Acre; inserted (e); and in Table 4.3, inserted footnote "m" and all references thereto in the body of the table.

Public Notice: Special area standards.

See: 33 N.J.R. 897(a).

Amended by R.2002 d.399, effective December 16, 2002.

See: 34 N.J.R. 2615(a), 34 N.J.R. 4412(a).

Rewrote Table 4.3.

5:21-4.3 Curbs or curbs and gutters

(a) Curbs or curbs and gutters shall be used for drainage purposes, safety, and delineation and protection of pavement edge. Where, based on stormwater management system design, there is determined to be a problem with runoff, curbs or curbs and gutters shall be used.

(b) Curb requirements shall vary according to street hierarchy and intensity of development, in accordance with the requirements set forth in Table 4.3 in N.J.A.C. 5:21-4.2. Generally, curbs shall be required on streets with on-street parking.

(c) Where curbing is not required, edge definition and stabilization shall be furnished for safety reasons, and to prevent pavement unraveling. Curbing may be required for: stormwater management, road stabilization, delineation of parking areas, 10 feet on each side of drainage inlets, intersections, corners, and tight radii.

(d) Curb requirements may be waived by the appropriate municipal approving agency, and shoulders and/or drainage swales used when it can be shown that: shoulders are required by CAFRA; soil and/or topography make the use of shoulders and/or drainage swales preferable; and/or the community desires to preserve its rural character by using shoulders and/or drainage swales instead of curbs. In cases of medium development intensity, the curbing requirement may be waived where front setbacks exceed 40 feet and it can be demonstrated that sufficient on-site parking exists.

(e) A municipality may designate a curb type by ordinance. Where curb type is not established by municipal ordinance, flexibility regarding curb type shall be permitted as long as the curb type accommodates the system of drainage proposed. Generally, curbs should be constructed of concrete or granite block. Curbing materials shall accommodate the purposes set forth in (c) above.

(f) Curbs shall be constructed according to the specifications set forth in N.J.A.C. 5:21-4.17.

(g) Curbing shall be designed to provide a curb ramp in compliance with the Americans with Disabilities Act or the Barrier Free Subcode of the New Jersey Uniform Construction Code (N.J.A.C. 5:23-7) at street intersections, as applicable.

(h) Where curbs and gutters are used and where the street is part of a designated bike route as indicated in the bicycle circulation part of the municipal master plan, the municipality may require that the cartway width be increased by one foot on each side of a street that uses a curb and gutter.

Amended by R.2000 d.480, effective December 4, 2000 (operative June 3, 2001).

See: 32 N.J.R. 2670(b), 32 N.J.R. 4277(a).

Added (h).

5:21-4.4 Shoulders

(a) Shoulders should be used instead of curbs when:

1. Shoulders are required by CAFRA;
2. Soil and/or topography make the use of shoulders preferable; and/or
3. To preserve rural character.

(b) Shoulders shall be provided in accordance with the requirements in Table 4.3 in N.J.A.C. 5:21-4.2.

(c) Shoulders shall be four feet wide, except for minor collector streets of high intensity with off-street parking, which shall be six feet wide on each side for all streets, and major collector streets of medium and high intensity, which shall be eight feet wide on each side for all streets. Shoulders shall be located within the right-of-way as shown in the following street illustrations.

(d) Shoulders shall be constructed of materials such as stabilized earth, gravel, crushed stone, bituminous treatment, or other forms of pavement which provide for vehicle load support. Shoulders along major collectors and shoulders along streets that are part of a designated bike path as indicated in the bicycle circulation portion of the municipal master plan shall be paved with asphalt pavement.

Amended by R.1999 d.374, effective November 1, 1999 (operative May 1, 2000).

See: 31 N.J.R. 477(a), 31 N.J.R. 3259(a).

Rewrote (c).

Amended by R.2000 d.480, effective December 4, 2000 (operative June 3, 2001).

See: 32 N.J.R. 2670(b), 32 N.J.R. 4277(a).

In (a) and (a)2, deleted "and/or drainage swales" preceding "preferable"; and in (d), inserted the last sentence.

5:21-4.5 Sidewalks and graded areas

(a) Sidewalks and/or graded areas shall be required, depending on road classification and intensity of development, in accordance with the requirements set forth in Table 4.3 in N.J.A.C. 5:21-4.2.

(b) Sidewalks shall be provided where graded areas are specified in Table 4.3 when the conditions described in (b)1 or 2 below exist:

1. The minimum lot size in the development is smaller than one acre; and
 - i. The development or project is located within 2,500 feet of a train station, public or school bus route;
 - ii. The development or project is located within 2,500 feet of an existing recreational, business or retail use or a site where such use is permitted by existing zoning; or

iii. Where the proposed streets connect to or extend existing streets which have sidewalks on both sides; or

2. The minimum lot size in the development is smaller than two acres and the development is located within two miles of a school.

(c) Notwithstanding (b)1 and 2 above, sidewalks shall only be required on one side of rural streets or rural lanes and shall not be required in alleys.

(d) Sidewalks shall be placed parallel to the street, as shown in the street profile figures, unless an exception has been permitted to preserve topographical or natural features, or if required to provide visual interest, or unless the applicant shows that an alternative pedestrian system provides safe and convenient circulation (for example, in planned development).

(e) Sidewalks along streets with nonparallel parking shall be placed parallel to the street, and shall be placed so that sidewalks do not lead pedestrians between parked vehicles and the traveled way. This subsection shall not apply to driveways.

(f) Pedestrian-way easements at least 10-foot wide may be required by the municipal approving authority through the center of blocks more than 600-foot long. In providing circulation or access to schools, playgrounds, shopping, adjoining residential areas, or other community facilities, the municipality shall consider and may require pedestrian-way easements.

(g) Sidewalk width shall be four feet; wider widths may be necessary near pedestrian generators and employment centers. Where sidewalks abut the curb and cars overhang the sidewalk, widths shall be six feet. In high-density residential areas when sidewalks abut the curb, a sidewalk/graded area of at least six feet in width shall be required.

(h) Sidewalks and graded areas shall be constructed according to the specifications set forth in N.J.A.C. 5:21-4.18.

ILLUSTRATIONS OF STREET LAYOUTS FOLLOW:

Note: The individual components shown in the non-travel-way portion of the right-of-way such as utility areas, sidewalks, and graded areas are indicated for illustrative purposes only. Municipalities may vary the placement and dimensions of these individual items, depending on utility company requirements and local practice and preferences. In addition, items such as shade trees may be accommodated within the total right-of-way widths indicated for each street type. Several street types are not illustrated because of the limited or various, as the case may be, design possibilities.

**RESIDENTIAL ACCESS
(low intensity)**

Illustration 1 of 14

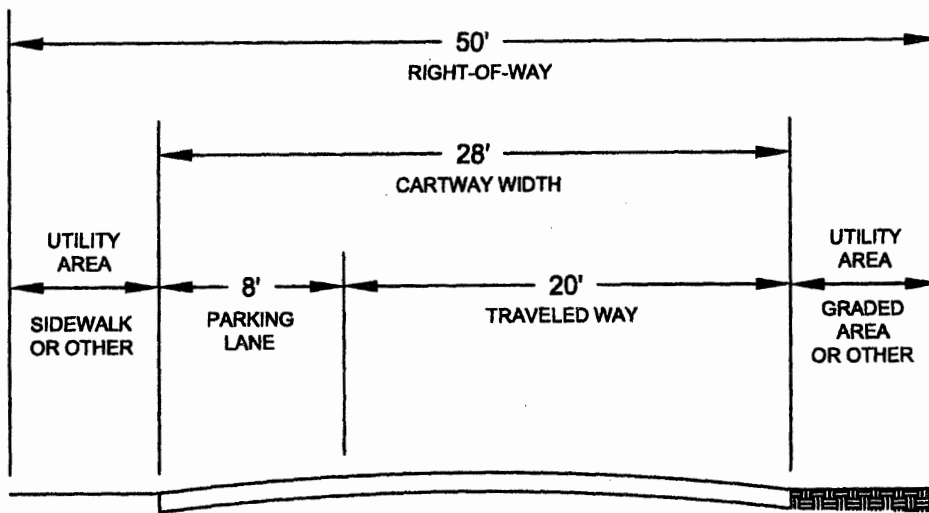

FOR ILLUSTRATIVE PURPOSES ONLY

TRAVELED WAY:	20 FEET
NUMBER OF PARKING LANES:	1
PARKING LANE WIDTH:	8 FEET
CARTWAY WIDTH:	28 FEET
CURB OR SHOULDER:	NONE
SIDEWALK OR GRADED AREA:	1 SW 1 GA
RIGHT-OF-WAY:	50 FEET

RESIDENTIAL ACCESS
 (high intensity with on-street parking
 and medium intensity)

Illustration 2 of 14

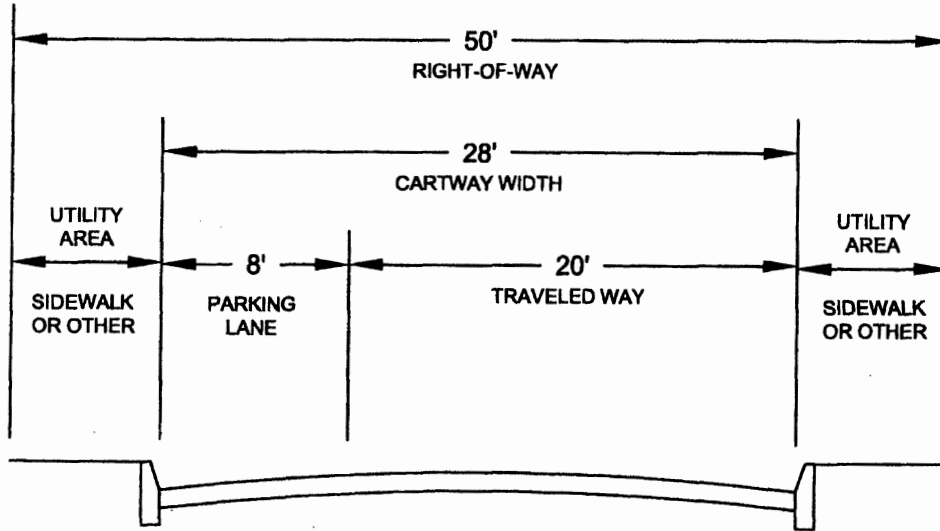

FOR ILLUSTRATIVE PURPOSES ONLY

TRAVELED WAY:	20 FEET
NUMBER OF PARKING LANES:	1
PARKING LANE WIDTH:	8 FEET
CARTWAY WIDTH:	28 FEET
CURB OR SHOULDER:	CURB
SIDEWALK OR GRADED AREA:	2 SW
RIGHT-OF-WAY:	50 FEET

RESIDENTIAL ACCESS
(high intensity with off-street parking)

Illustration 3 of 14

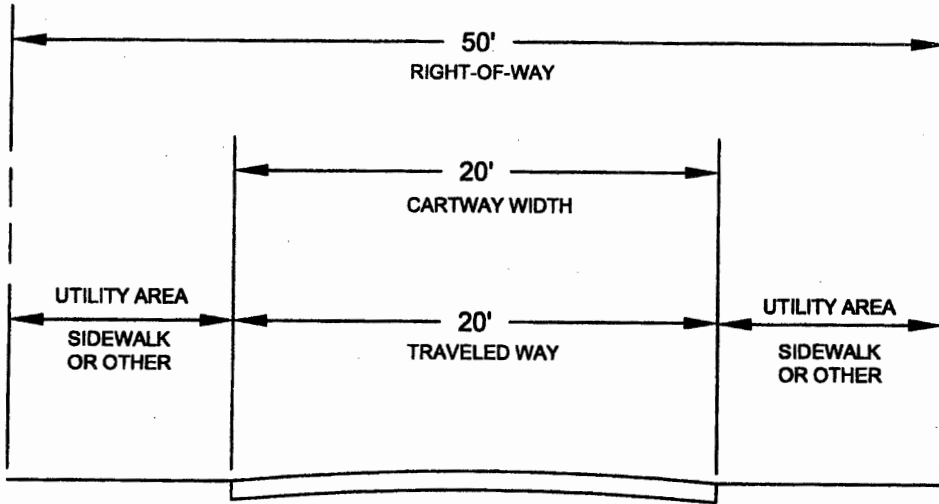

FOR ILLUSTRATIVE PURPOSES ONLY

TRAVELED WAY:	20 FEET
NUMBER OF PARKING LANES:	0
PARKING LANE WIDTH:	0 FEET
CARTWAY WIDTH:	20 FEET
CURB OR SHOULDER:	NONE
SIDEWALK OR GRADED AREA:	2 SW
RIGHT-OF-WAY:	50 FEET

NEIGHBORHOOD
(all intensities)

Illustration 4 of 14

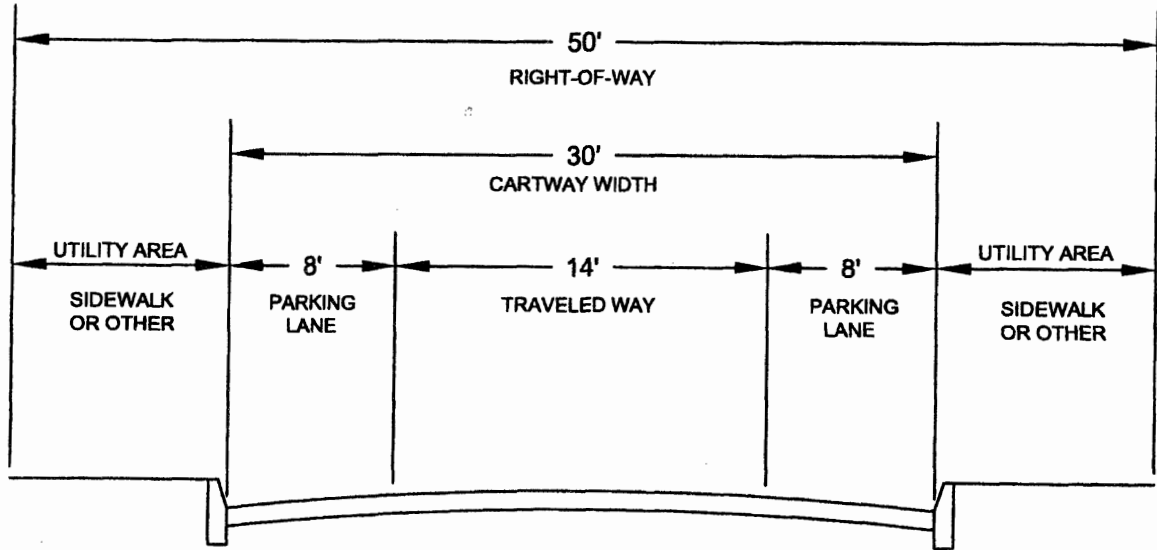

FOR ILLUSTRATIVE PURPOSES ONLY

TRAVELED WAY:	14 FEET
NUMBER OF PARKING LANES:	2
PARKING LANE WIDTH:	16 FEET
CARTWAY WIDTH:	30 FEET
CURB OR SHOULDER:	CURB
SIDEWALK OR GRADED AREA:	2 SW
RIGHT-OF-WAY:	50 FEET

MINOR COLLECTOR
 (low intensity with no parking)

Illustration 5 of 14

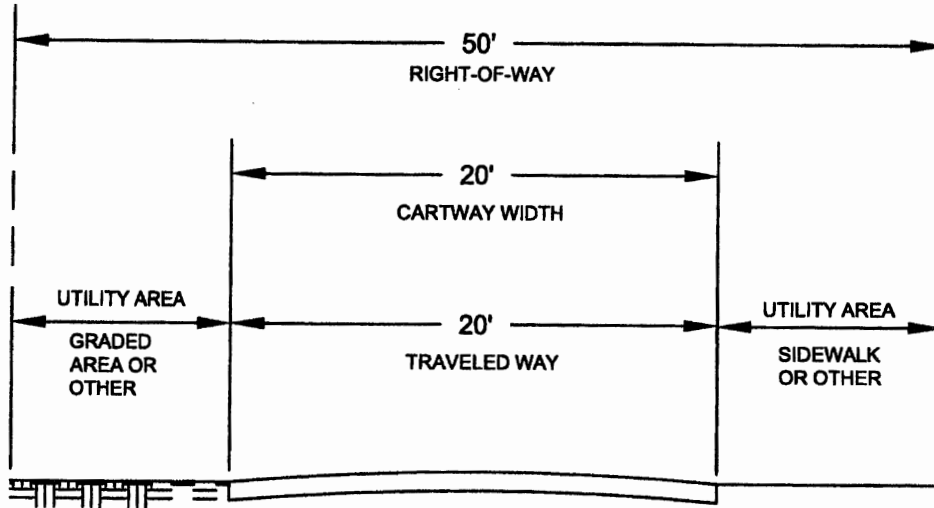

FOR ILLUSTRATIVE PURPOSES ONLY

TRAVELED WAY:	20 FEET
NUMBER OF PARKING LANES:	0
PARKING LANE WIDTH:	0 FEET
CARTWAY WIDTH:	20 FEET
CURB OR SHOULDER:	NONE
SIDEWALK OR GRADED AREA:	1 SW 1 GA
RIGHT-OF-WAY:	50 FEET

MINOR COLLECTOR
 (low, medium, and high intensity
 with one parking lane)

Illustration 6 of 14

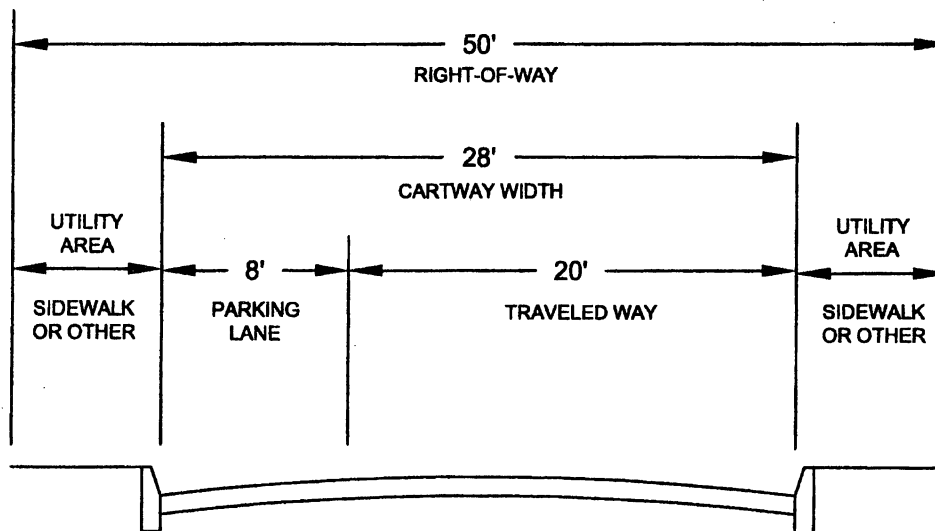

FOR ILLUSTRATIVE PURPOSES ONLY

TRAVELED WAY:	20 FEET
NUMBER OF PARKING LANES:	1
PARKING LANE WIDTH:	8 FEET
CARTWAY WIDTH:	28 FEET
CURB OR SHOULDER:	CURB
SIDEWALK OR GRADED AREA:	
low, one parking lane:	1SW, 1GA
medium, one parking lane:	2 SW
high, one parking lane:	2 SW
RIGHT-OF-WAY:	50 FEET

MINOR COLLECTOR
 (medium and high intensities
 with two parking lanes)

Illustration 7 of 14

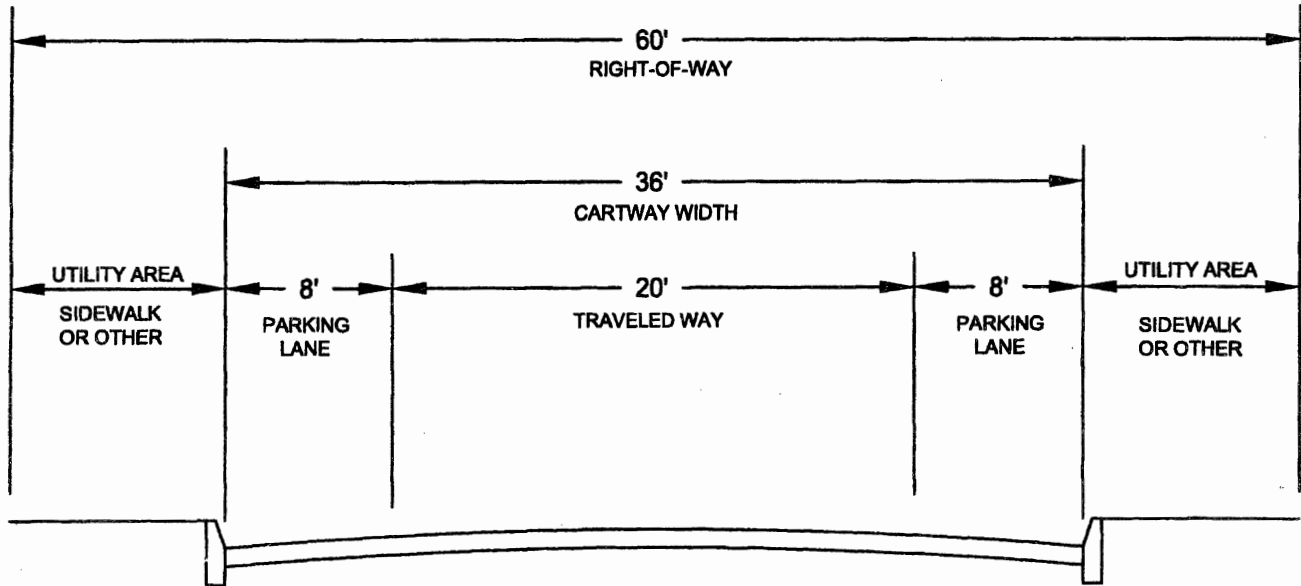

FOR ILLUSTRATIVE PURPOSES ONLY

TRAVELED WAY:	20 FEET
NUMBER OF PARKING LANES:	2
PARKING LANE WIDTH:	16 FEET
CARTWAY WIDTH:	36 FEET
CURB OR SHOULDER:	CURB
SIDEWALK OR GRADED AREA:	2 SW
RIGHT-OF-WAY:	60 FEET

MINOR COLLECTOR
 (medium and high intensity
 with off-street parking
 and shoulders)

Illustration 8 of 14

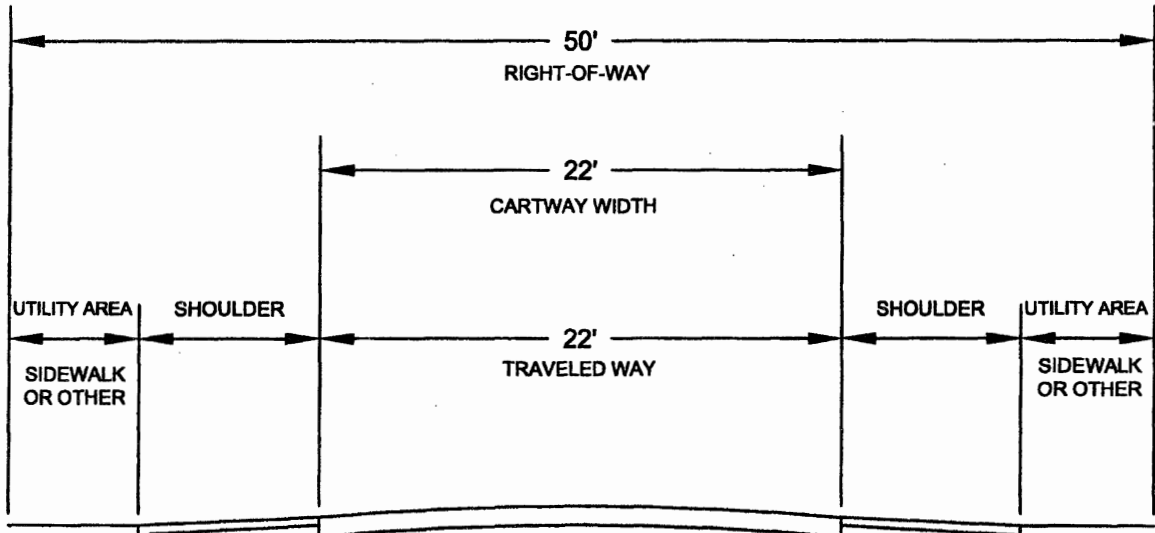

FOR ILLUSTRATIVE PURPOSES ONLY

TRAVELED WAY:	22 FEET
NUMBER OF PARKING LANES:	0
PARKING LANE WIDTH:	0 FEET
CARTWAY WIDTH:	22 FEET
CURB OR SHOULDER:	SHOULDER
medium intensity:	4 FEET
high intensity:	6 FEET
SIDEWALK OR GRADED AREA:	2 SW
RIGHT-OF-WAY:	50 FEET

MINOR COLLECTOR
 (medium and high intensity
 with off-street parking and curb)

Illustration 9 of 14

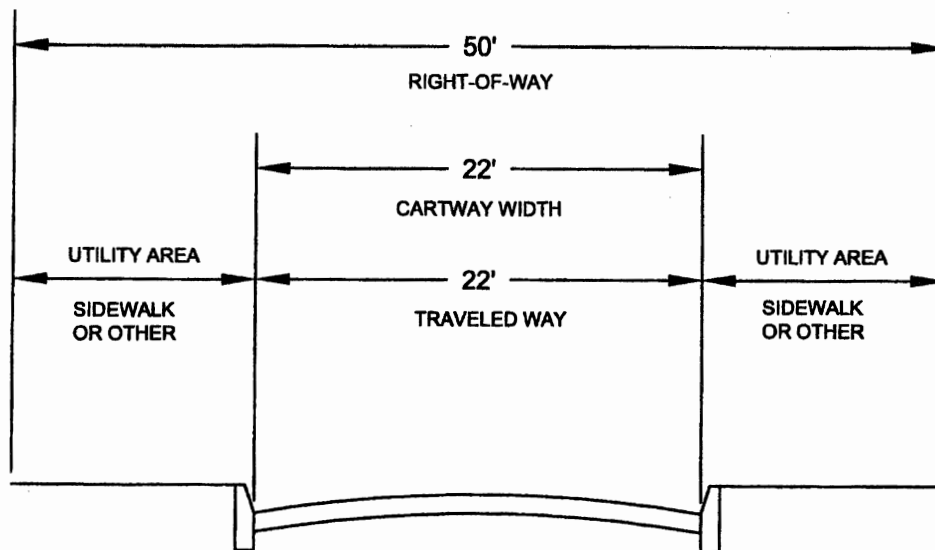

FOR ILLUSTRATIVE PURPOSES ONLY

TRAVELED WAY:	22 FEET
NUMBER OF PARKING LANES:	1
PARKING LANE WIDTH:	0 FEET
CARTWAY WIDTH:	22 FEET
CURB OR SHOULDER:	CURB
SIDEWALK OR GRADED AREA:	2 SW
RIGHT-OF-WAY:	50 FEET

**MAJOR COLLECTOR
(low intensity)**

Illustration 10 of 14

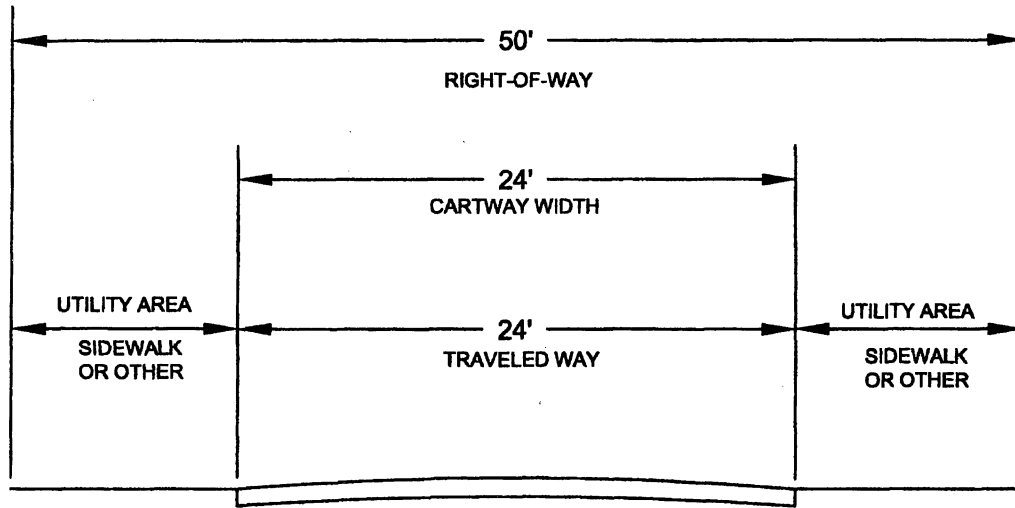

FOR ILLUSTRATIVE PURPOSES ONLY

TRAVELED WAY:	24 FEET
NUMBER OF PARKING LANES:	0
PARKING LANE WIDTH:	0 FEET
CARTWAY WIDTH:	24 FEET
CURB OR SHOULDER:	NONE
SIDEWALK OR GRADED AREA:	2 SW
RIGHT-OF-WAY:	50 FEET

MAJOR COLLECTOR
 (medium and high intensity with curb)

Illustration 11 of 14

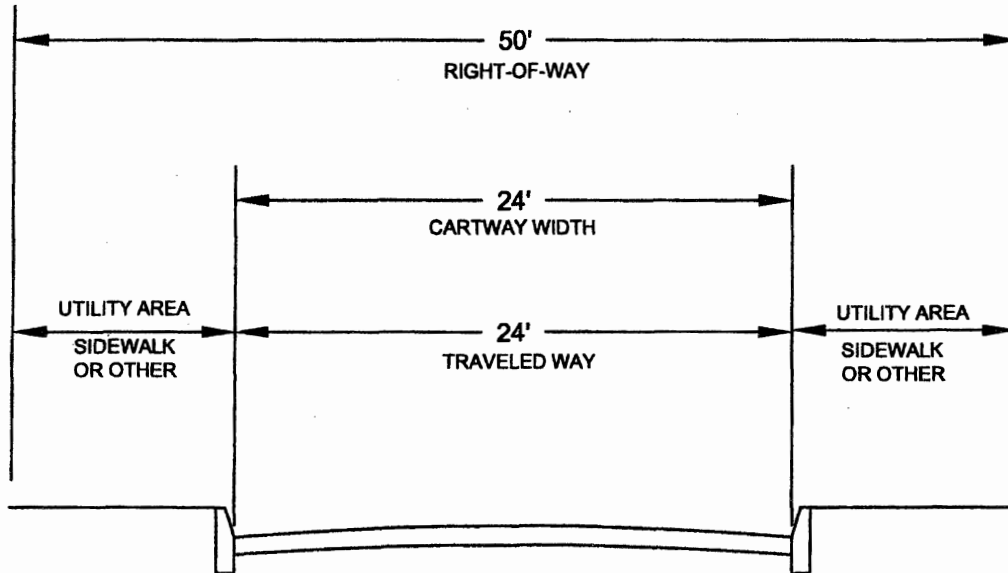

FOR ILLUSTRATIVE PURPOSES ONLY

TRAVELED WAY:	24 FEET
NUMBER OF PARKING LANES:	0
PARKING LANE WIDTH:	0 FEET
CARTWAY WIDTH:	24 FEET
CURB OR SHOULDER:	CURB
SIDEWALK OR GRADED AREA:	2 SW
RIGHT-OF-WAY:	50 FEET

MAJOR COLLECTOR
 (medium and high intensity
 with shoulders)

Illustration 12 of 14

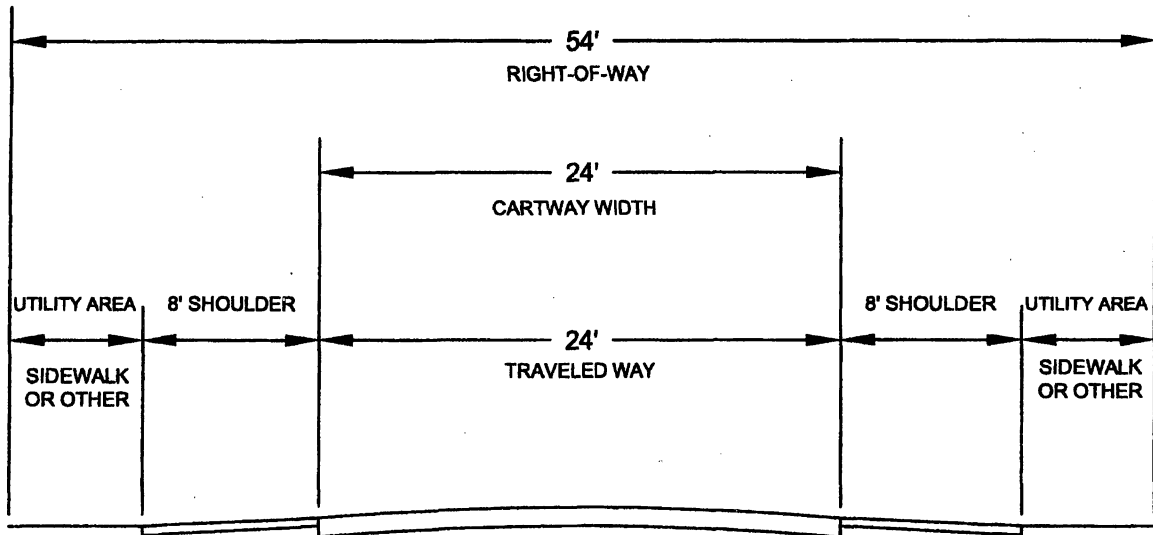

FOR ILLUSTRATIVE PURPOSES ONLY

TRAVELED WAY:	24 FEET
NUMBER OF PARKING LANES:	0
PARKING LANE WIDTH:	0 FEET
CARTWAY WIDTH:	24 FEET
CURB OR SHOULDER:	SHOULDER
SIDEWALK OR GRADED AREA:	2 SW
RIGHT-OF-WAY:	54 FEET

MULTIFAMILY COURT

Illustration 13 of 14

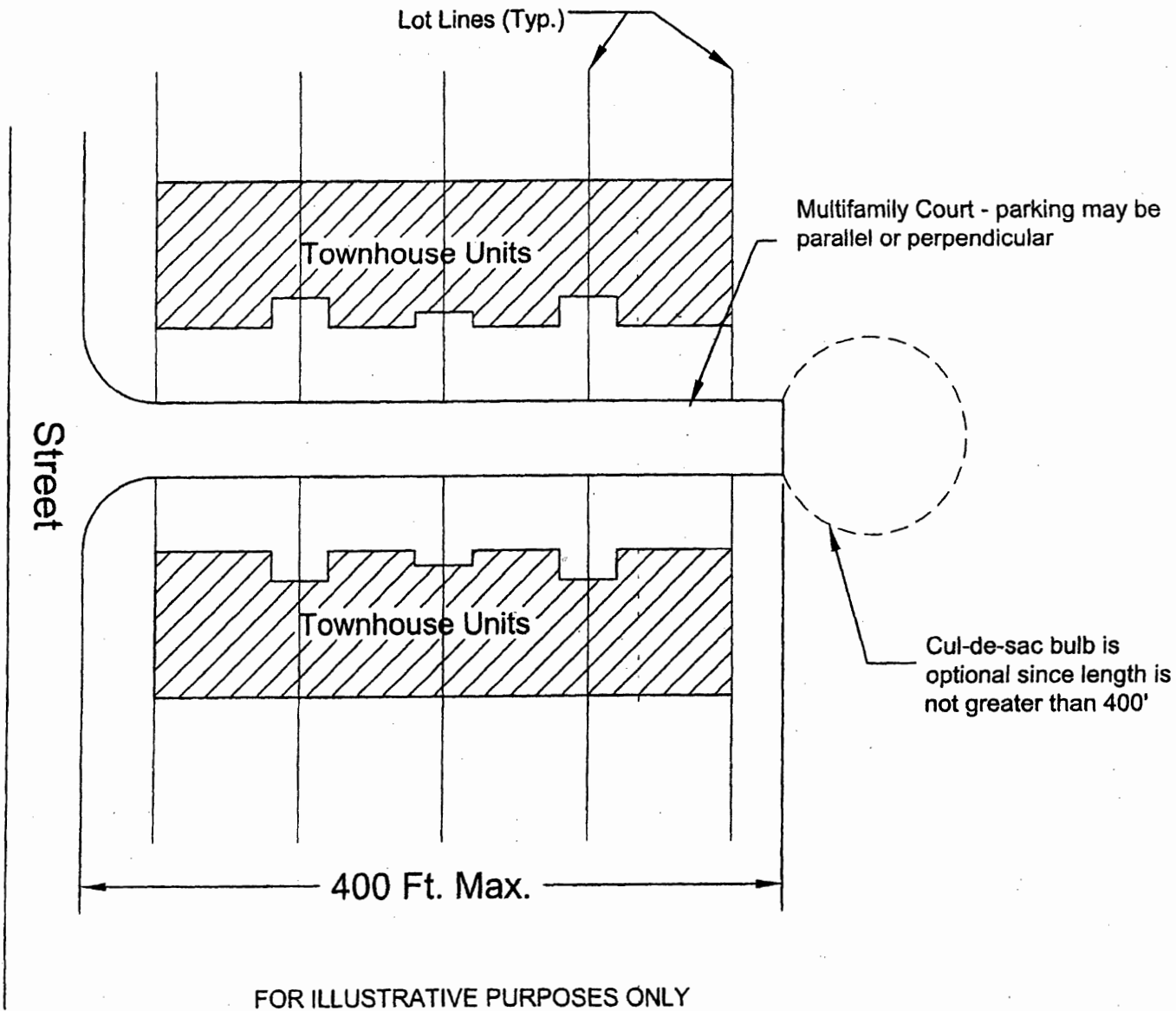

MULTIFAMILY
CUL-DE-SAC

Illustration 14 of 14

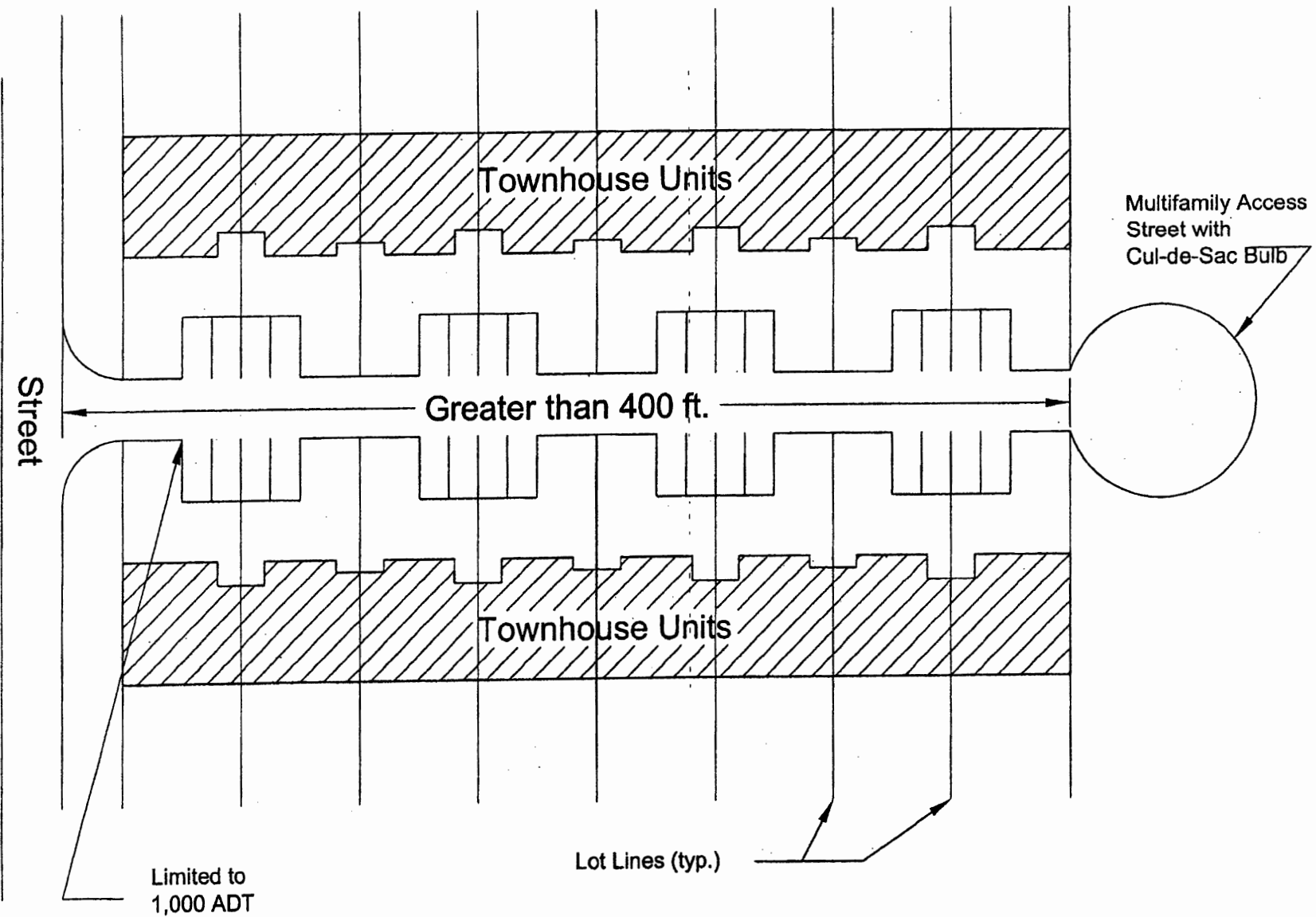

FOR ILLUSTRATIVE PURPOSES ONLY

Administrative correction.

See: 29 N.J.R. 1296(a).

Amended by R.1999 d.374, effective November 1, 1999 (operative May 1, 2000).

See: 31 N.J.R. 477(a), 31 N.J.R. 3259(a).

Public Notice: Special area standards.

See: 33 N.J.R. 897(a).

Amended by R.2002 d.399, effective December 16, 2002.

See: 34 N.J.R. 2615(a), 34 N.J.R. 4412(a).

Rewrote (b)1; added new (e); recodified former (e) through (g) as new (f) through (h); added Illustrations 13 and 14.

5:21-4.6 Bikeways

(a) Separate bicycle paths and lanes shall be required only if such paths and lanes have been specified as part of a municipality's adopted master plan and/or official map.

(b) Bicycle lanes, where provided, shall be placed in the outside lane of a roadway, adjacent to the curb or shoulder. When on-street parking is permitted, the bicycle lane shall be between the parking lane and the outer lane of moving vehicles. Lanes shall be delineated with markings, preferably striping. Raised reflectors or curbs shall not be used.

(c) The construction of bikeways shall comply with the specifications set forth in N.J.A.C. 5:21-4.18.

5:21-4.7 Utility areas

(a) Utility mains shall be located within the right-of-way or within utility easements outside the right-of-way.

(b) Utility areas shall be planted with grass, ground cover, or treated with other suitable cover material.

Amended by R.1999 d.374, effective November 1, 1999 (operative May 1, 2000).

See: 31 N.J.R. 477(a), 31 N.J.R. 3259(a).

Rewrote (a).

5:21-4.8 Right-of-way and cartway

(a) The right-of-way shall be measured from lot line to lot line. Right-of-way requirements are shown in Table 4.3 in N.J.A.C. 5:21-4.2 and displayed graphically in the street illustrations in N.J.A.C. 5:21-4.5.

(b) The municipal approving authority may require the right-of-way and cartway widths of a new street that is a continuation of an existing street to be at least the same widths as the existing street.

(c) The right-of-way shall be of sufficient width to accommodate future development, as indicated by the municipal master plan.

(d) Where turning lanes are needed based on safety or capacity, additional right-of-way width, not to exceed the width and length of the turning lanes, may be required.

5:21-4.9 Street grade and intersections

Street grade and intersection design shall be constructed according to the specifications set forth in N.J.A.C. 5:21-4.19.

5:21-4.10 Pavement

(a) Street pavement thickness shall vary by street hierarchy, subgrade properties, and pavement type.

(b) Pavement design for rural, residential access, neighborhood, minor collector, and major collector streets shall conform to the specifications in N.J.A.C. 5:21-4.19.

5:21-4.11 Street and site lighting (Reserved)

5:21-4.12 Underground wiring

(a) All electric, telephone, television, and other communication facilities, both main and service lines servicing new developments, shall be provided by underground wiring within easements or dedicated public rights-of-way, installed in accordance with the prevailing standards and practices of the utility or other companies providing such services.

(b) Lots that abut existing easements or public rights-of-way, where overhead electric or telephone distribution supply lines and service connections have heretofore been installed, may be supplied with electric and telephone service from those overhead lines, but the service connections from the utilities' overhead lines shall be installed underground.

(c) Overhead lines may be permitted as an exception by the municipal approving authority in areas of severe geological conditions. The placement and alignment of the poles shall be designed to lessen the visual impact of overhead lines.

5:21-4.13 Street and traffic signs

(a) Design and placement of traffic signs included in "Manual on Uniform Traffic Control Devices for Streets and Highways" shall follow the requirements specified in "Manual on Uniform Traffic Control Devices for Streets and Highways," published by the U.S. Department of Transportation and adopted by the N.J. Department of Transportation.

(b) At least two street name signs shall be placed at each four-way street intersection and one at each "T" intersection. Signs shall be placed so as not to obstruct sight distances and under light standards, if present, so that they are clearly visible. The design of street name signs should be: consistent, of a style appropriate to the community, of a uniform size and color, and erected in accordance with local standards.

(c) At signalized intersections, street signs shall be located on the overhead arm supporting the traffic signal, or otherwise suitably suspended over the intersection. Roadway clearance shall be a minimum of 15 feet from the bottom of any sign or supporting equipment and the top of the paved surface.

5:21-4.14 Parking: number of spaces

(a) An adequate number of on-street and off-street parking spaces shall be required in all developments to accommodate residents and visitors. For projects containing dwelling units required by the New Jersey Uniform Construction Code's Barrier Free Subcode (N.J.A.C. 5:23-7) to be accessible, accessible parking spaces for people with disabilities shall be provided in accordance with the requirements of the Barrier Free Subcode and shall be considered part of the total number of required spaces.

(b) For residential developments, parking shall be provided, as set forth in Table 4.4 below. If applicant does not specify the number of bedrooms per unit, note "c" for each category in Table 4.4 shall apply for the parking requirement.

(c) Alternative parking standards to those shown in Table 4.4 shall be accepted if the applicant demonstrates these standards better reflect local conditions. Factors affecting minimum number of parking spaces include household characteristics, availability of mass transit, urban versus suburban location, and available off-site parking resources.

(d) Garage and driveway combinations shall be counted as follows:

1. Each garage car space shall be counted as 1.0 off-street parking space regardless of the dimensions of the driveway.
2. A one-car garage and driveway combination shall count as 2.0 off-street parking spaces, provided the driveway measures a minimum of 18 feet in length between the face of the garage door and the right-of-way.
3. A two-car garage and driveway combination shall count as 3.5 off-street parking spaces, provided a minimum parking width of 20 feet is provided for a minimum length of 18 feet as specified for a one-car garage and driveway combination.

(e) When housing is included in mixed-use development, a shared parking approach to the provision of parking shall be permitted.

(f) When, in the judgment of the local approving authority, on-street parking is available, then only that proportion of the parking requirement which is not available on the street shall be provided in off-street parking facilities. A length of 23 feet per on-street parking space shall be used in calculating the number of available on-street parking spaces.

TABLE 4.4
PARKING REQUIREMENTS FOR
RESIDENTIAL LAND USES^a

Housing unit type/size ^b	Parking requirement per dwelling unit
Single-Family Detached	
2 Bedroom	1.5
3 Bedroom	2.0
4 Bedroom	2.5 ^c
5 Bedroom	3.0
Two Family (Duplex)	"Single-Family Detached" values shall apply to each unit.
Garden Apartment	
1 Bedroom	1.8
2 Bedroom	2.0 ^c
3 Bedroom	2.1
Townhouse	
1 Bedroom	1.8
2 Bedroom	2.3 ^c
3 Bedroom	2.4
High Rise	
1 Bedroom	0.8
2 Bedroom	1.3 ^c
3 Bedroom	1.9
Mobile Home	
1 Bedroom	1.8
2 Bedroom	2.0 ^c
Retirement Community	Values shall be commensurate with the most appropriate housing unit type and size noted above that the retirement community resembles.
Recreational Homes (owner occupied)	Values shall be commensurate with the most appropriate housing unit type and size noted above that the recreational homes (owner occupied) resemble.
Mid-Rise Apartment	"Garden Apartment" values shall apply
Assisted living	0.50

Notes: ^a When determination of the required number of parking spaces results in a fractional space for the entire development, any fraction of one-half or less may be disregarded, while a fraction in excess of one-half shall be counted as one parking space. ^b Requirements for attached units (apartment/condominium/ townhouse) include provisions for guest parking. ^c If applicant does not specify the number of bedrooms per unit, this off-street parking requirement shall apply.

Source: Modified and adapted from U.S. Department of Commerce, Bureau of the Census, Public Use File—New Jersey (cross-tabulation of vehicles by housing unit for units constructed 1975 to 1980).

Notes:

^aWhen determination of the required number of parking spaces results in a fractional space for the entire development, any fraction of one-half or less may be disregarded, while a fraction in excess of one-half shall be counted as one parking space.

^bRequirements for attached units (apartment/condominium/townhouse) include provisions for guest parking (0.5 spaces per dwelling unit). Guest parking must either be provided for on street or in common parking areas.

^cIf applicant does not specify the number of bedrooms per unit, this parking requirement shall apply.

Source: Modified and adapted from U.S. Department of Commerce, Bureau of the Census, Public Use File—New Jersey (cross-tabulation of vehicles by housing unit for units constructed 1975 to 1980).

Amended by R.1999 d.374, effective November 1, 1999 (operative May 1, 2000).

See: 31 N.J.R. 477(a), 31 N.J.R. 3259(a).

Rewrote (d); and in Table 4.4, deleted “offstreet” preceding “parking” in Note c.

Administrative correction.

See: 32 N.J.R. 684(b).

Amended by R.2000 d.480, effective December 4, 2000 (operative June 3, 2001).

See: 32 N.J.R. 2670(b), 32 N.J.R. 4277(a).

In Table 4.4, amended column headings and inserted requirement for assisted living.

Amended by R.2002 d.399, effective December 16, 2002.

See: 34 N.J.R. 2615(a), 34 N.J.R. 4412(a).

In Table 4.4, added “Two Family (Duplex)” and rewrote footnote b.

5:21-4.15 Parking space size

Each off-street parking space shall measure nine feet in width by 18 feet in length. Parking spaces for people with disabilities shall be in accordance with the New Jersey Uniform Construction Code (N.J.A.C. 5:23) or the Americans with Disabilities Act, as applicable.

5:21-4.16 Parking lots

(a) Off-street parking lots shall be oriented to, and within a reasonable walking distance of, the buildings they are designed to serve.

(b) Access to parking lots shall be designed so as not to induce queues on travel ways, and to provide adequate pedestrian circulation and safety. There shall be adequate provision for ingress to and egress from all parking spaces to ensure ease of mobility, ample clearance, and safety of vehicles and pedestrians.

(c) The width of all aisles providing direct access to individual parking stalls shall be in accordance with the requirements specified in Table 4.5 below. Only one-way traffic shall be permitted in aisles serving single-row parking spaces placed at an angle other than 90 degrees.

TABLE 4.5

PARKING ANGLES AND AISLE WIDTHS

Parking angle (degrees)	Aisle width (feet)
30	12
45	13
60	18
90	24

(d) Where sidewalks occur in parking areas, parked vehicles shall not overhang or extend over the sidewalk unless an additional two feet of sidewalk width are provided to accommodate such overhang.

(e) Where sole access to dwelling units is via a parking lot, the following features shall be provided:

1. Designated fire lanes a minimum of 18 feet in width shall be required as provided for in the Uniform Fire Code.

2. Parking lots shall be provided with turning bays or other means of turning at intervals of not greater than 1,200 feet. Turning bays, such as hammerheads or other configurations, shall measure at least 18 feet by 60 feet, or provide equivalent maneuvering space.

3. Parking lots having more than 100 spaces shall have a minimum of two means of ingress and egress, or be provided with a divided-type entrance.

Amended by R.2002 d.399, effective December 16, 2002.

See: 34 N.J.R. 2615(a), 34 N.J.R. 4412(a).

In (a), substituted “lots” for “areas” following “Off-street parking”; added (e).

5:21-4.17 Curb construction standards

(a) Construction specifications for acceptable curb types of granite block and concrete are shown in Figure 4.1 below.

(b) The standard concrete curb section used shall be a maximum of 20 feet in length, with a scored joint every 10 feet. All concrete used for curbs or combination curbs and gutters shall be prepared in accordance with the requirements, by class of concrete, of the New Jersey Department of Transportation, *Standard Specifications for Road and Bridge Construction*, effective at the time of preparation. Where bituminous concrete pavement is used for the road surface, the curb and/or gutter shall be constructed first.

(c) Where drainage inlets are constructed but curbs are not required, curbing must be provided at least 10 feet on each side of the inlet, set back one foot from the extension of the pavement edge.

Figure 4.1
(1 of 6)

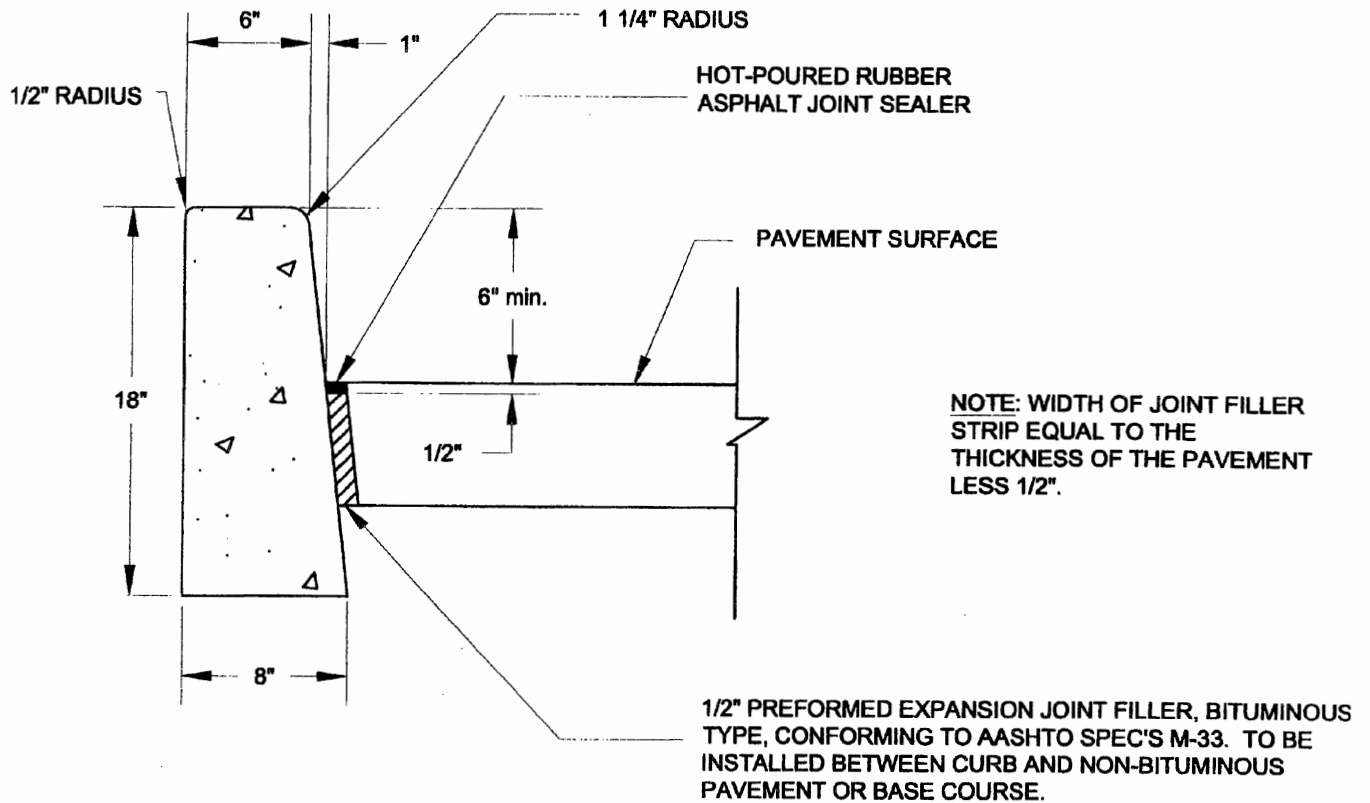

N.T.S.

NOTES: 1. CONCRETE TO BE NJDOT CLASS "B" (AIR ENTRAINED).

2. TRANSVERSE JOINTS 1/2" WIDE SHALL BE INSTALLED IN THE CURB 20' - 0" APART AND SHALL BE FILLED WITH PREFORMED, BITUMINOUS-IMPREGNATED FIBER JOINT FILLER, COMPLYING WITH THE REQUIREMENTS OF AASHTO M-213, RECESSED 1/4" FROM THE FRONT FACE AND TOP OF THE CURB.

3. DUMMY JOINTS (FORMED) SHALL BE INSTALLED MIDWAY BETWEEN EXPANSION JOINTS.

CONCRETE VERTICAL CURB

Figure 4.1
(2 of 6)

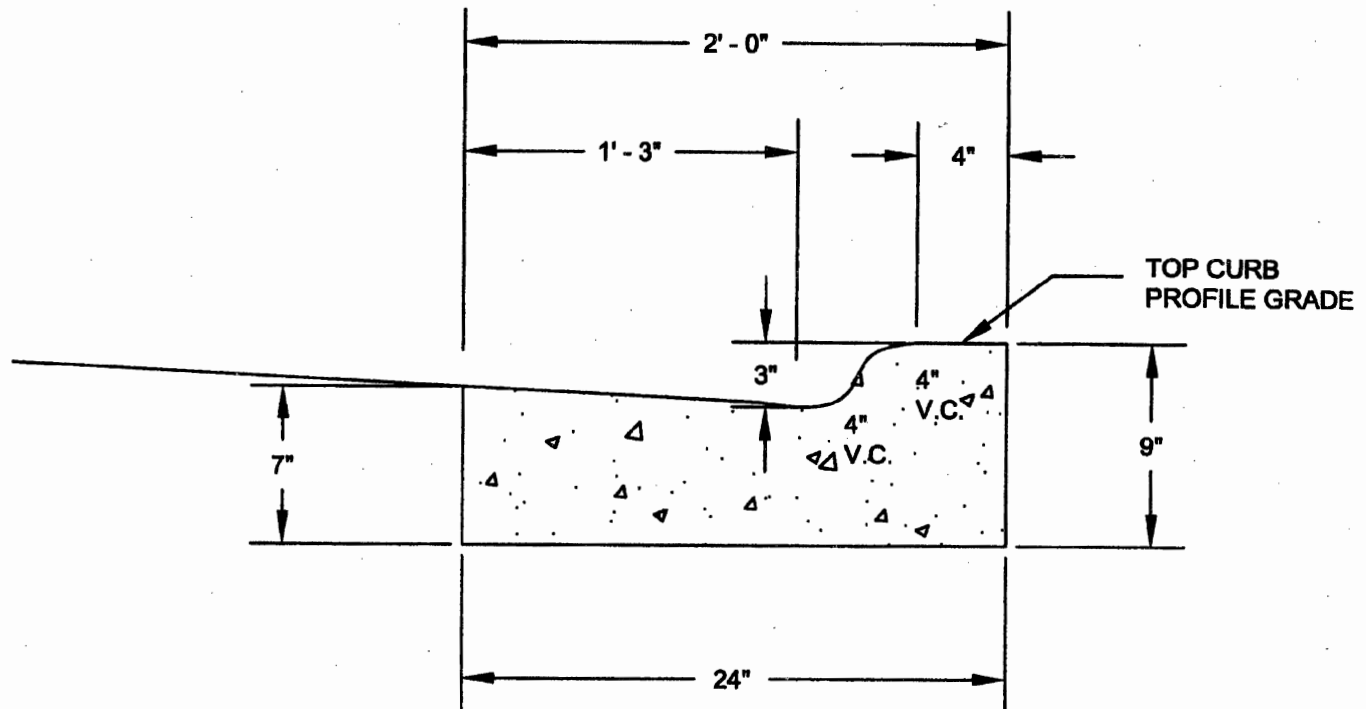

N.T.S.

NOTES: 1. CONCRETE TO BE NJDOT CLASS "B" (AIR ENTRAINED).

2. TRANSVERSE JOINTS 1/2" WIDE SHALL BE INSTALLED IN THE CURB 20' - 0" APART AND SHALL BE FILLED WITH PREFORMED, BITUMINOUS-IMPREGNATED FIBER JOINT FILLER, COMPLYING WITH THE REQUIREMENTS OF AASHTO M-213, RECESSED 1/4" FROM THE FRONT FACE AND TOP OF THE CURB.

3. DUMMY JOINTS (FORMED) SHALL BE INSTALLED MIDWAY BETWEEN EXPANSION JOINTS.

MOUNTABLE CONCRETE CURB

Figure 4.1
(3 of 6)

NOTE: JOINTS TO BE 1/2" WIDE USING
1-2 MIX CEMENT MORTAR STRUCK WITH
CONCRETE TOOL

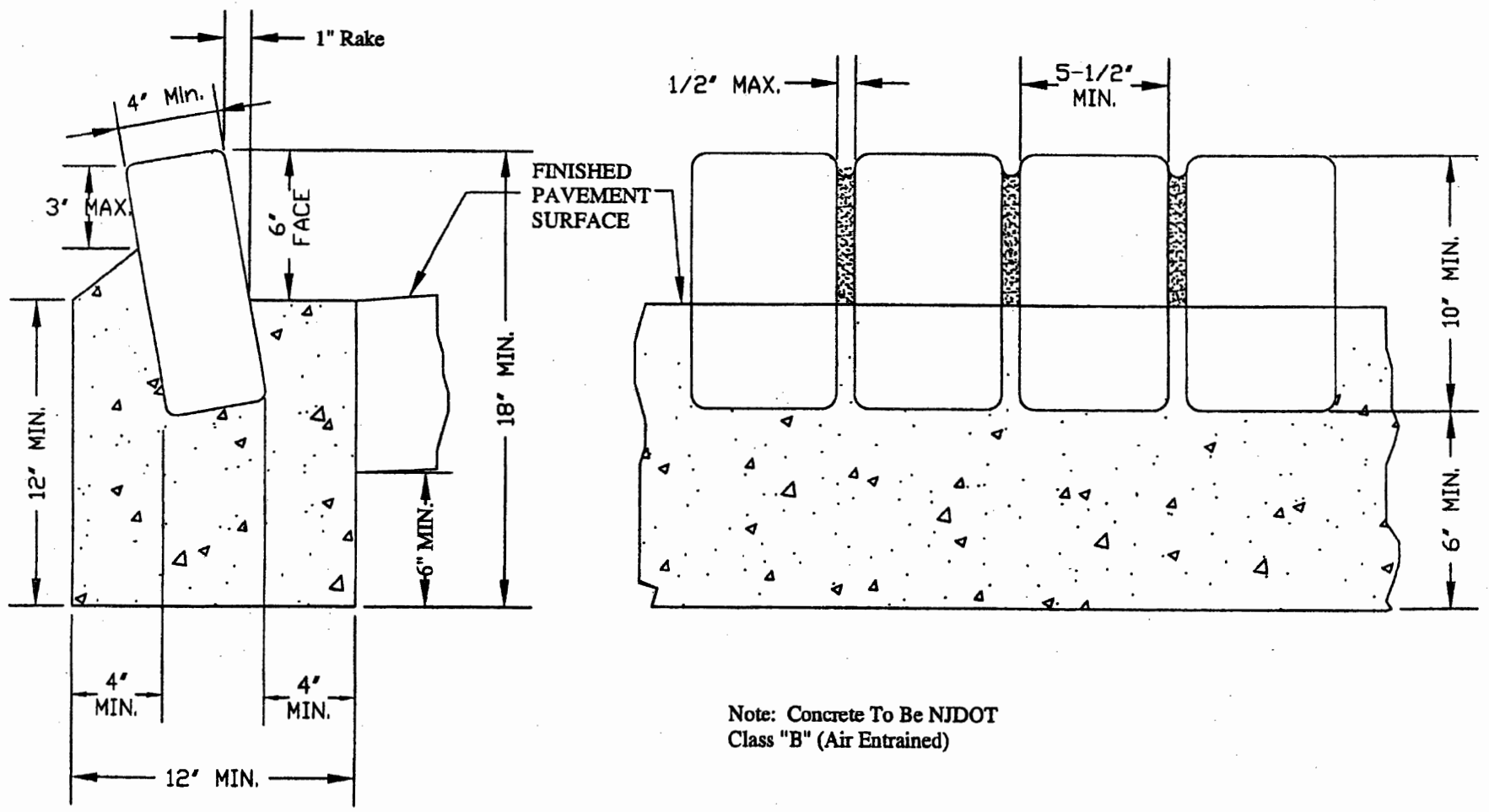

Note: Concrete To Be NJDOT
Class "B" (Air Entrained)

VERTICAL GRANITE BLOCK CURB

(NOT TO SCALE)

21-41

Supp. 12-16-02

Figure 4.1
(4 of 6)

NOTE: JOINTS TO BE 1/2' WIDE USING
1-2 MIX CEMENT MORTAR STRUCK WITH
CONCRETE TOOL

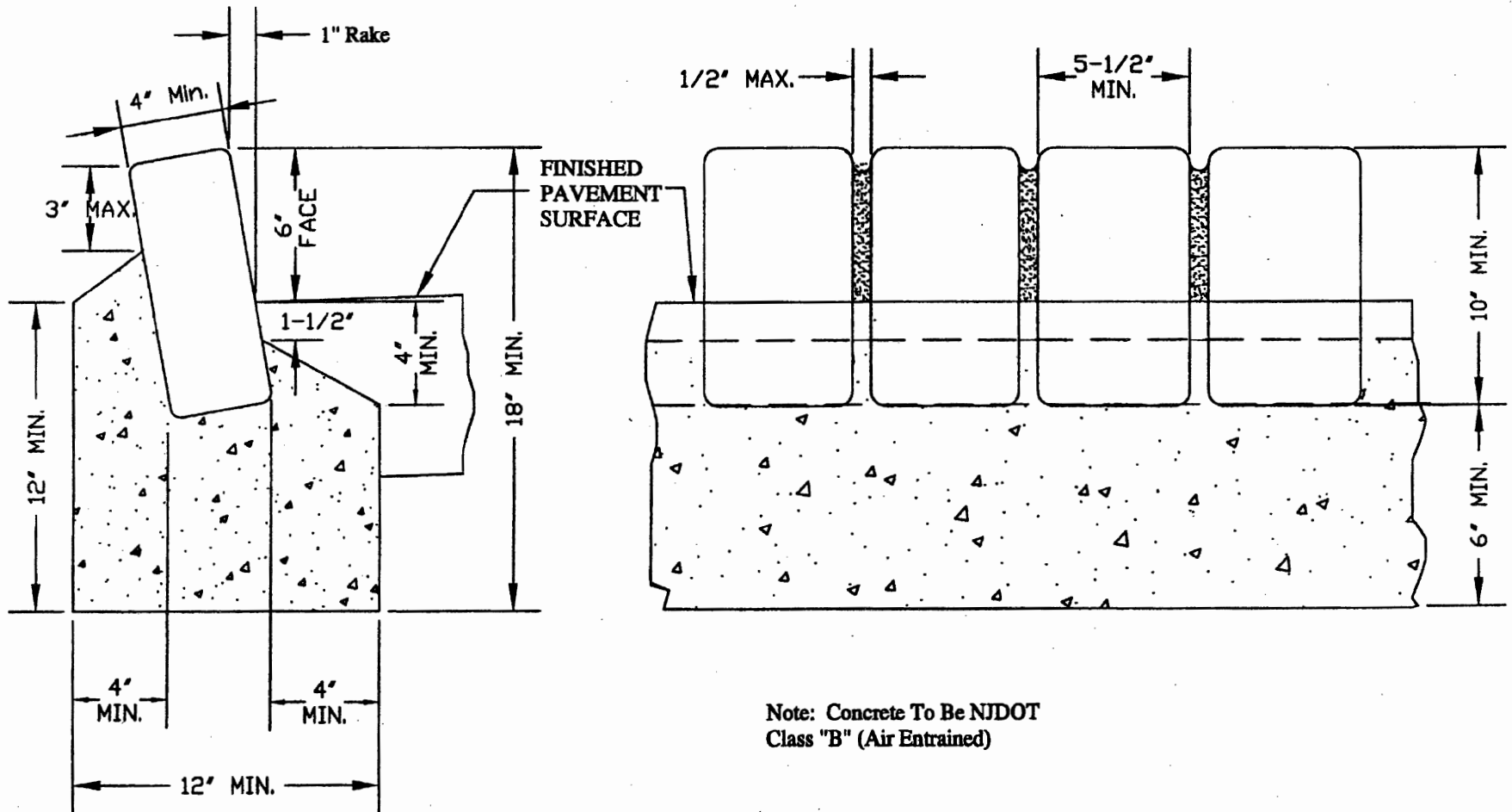

Note: Concrete To Be NJDOT
Class "B" (Air Entrained)

VERTICAL GRANITE BLOCK CURB

(NOT TO SCALE)

Figure 4.1
(5 of 6)

PLACEMENT OF GRANITE BLOCKS
ALTERNATE PLACEMENT PERMITTED

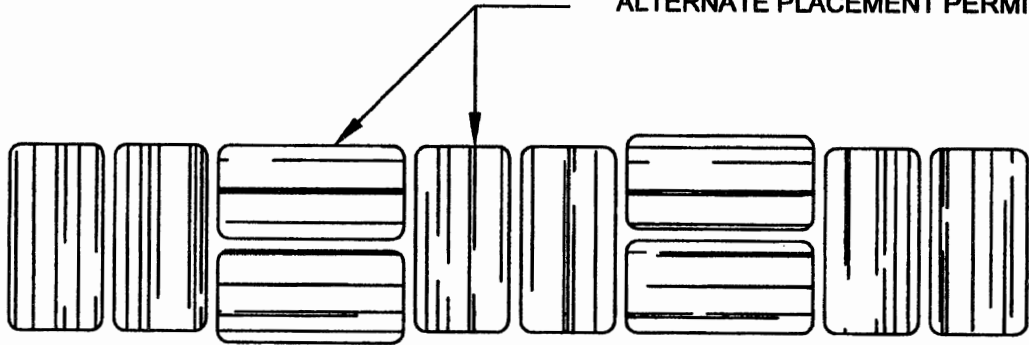

PLAN

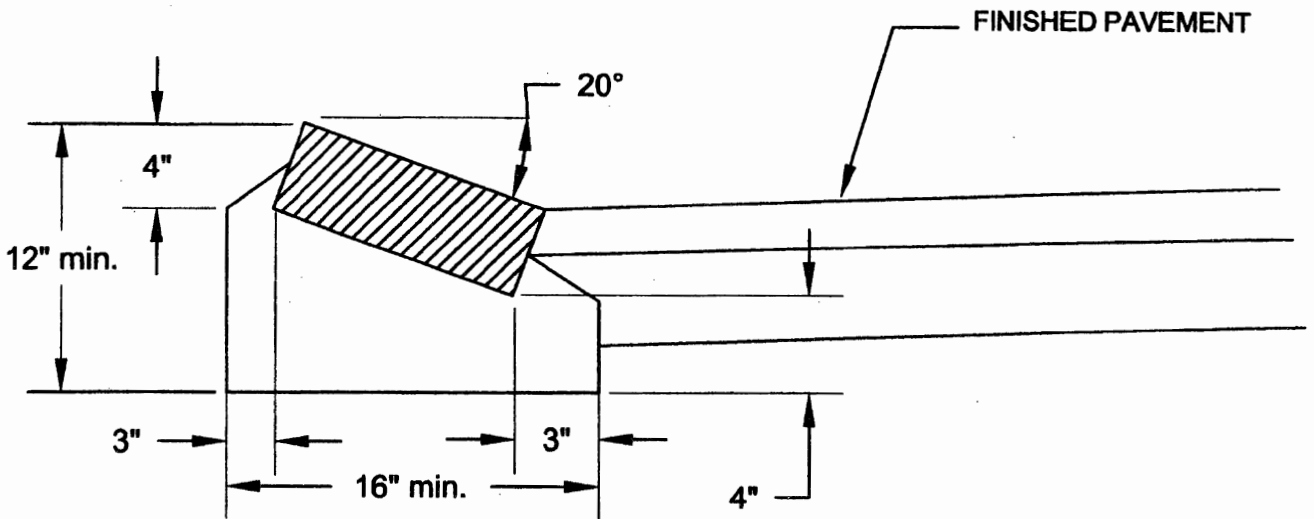

SECTION

MOUNTABLE GRANITE BLOCK CURB

Administrative correction.
 See: 29 N.J.R. 1296(a).
 Amended by R.1999 d.374, effective November 1, 1999 (operative May 1, 2000).
 See: 31 N.J.R. 477(a), 31 N.J.R. 3259(a).
 Administrative correction.
 See: 32 N.J.R. 684(b).
 Amended by R.2000 d.480, effective December 4, 2000 (operative June 3, 2001).
 See: 32 N.J.R. 2670(b), 32 N.J.R. 4277(a).
 In Figure 4.1, amended (1 of 5), (2 of 5) and (3 of 5).
 Amended by R.2002 d.399, effective December 16, 2002.
 See: 34 N.J.R. 2615(a), 34 N.J.R. 4412(a).
 Added Figure 4.1 (4 of 6); the elements of Figure 4.1 redesignated from "of 5" to "of 6"; amended Figure 4.1 (3 of 6).

5:21-4.18 Sidewalks and bikeways construction standards

- (a) The following apply to sidewalks and graded areas:
1. Sidewalks of concrete shall be four inches thick except at points of vehicular crossing, where they shall be at least six inches thick. At vehicular crossings, concrete sidewalks shall be reinforced with welded wire fabric mesh or an equivalent.
 2. Concrete, air-entrained sidewalks shall be Class B concrete, having a 28-day verification strength of 4,500 p.s.i. Other materials may be permitted, depending on the design of the development.
 3. Graded areas shall be planted with grass or treated with other suitable ground cover, and their width and cross slope shall correspond to that of sidewalks.

- (b) The following apply to bikeways:
1. The construction of bikeways shall conform to the New Jersey Department of Transportation Planning and Design Guidelines for Bicycle Compatible Roadways and Bikeways (November 1995) and the AASHTO Guide for the Development of Bicycle Facilities (1999), incorporated herein by reference.
 2. Bicycle-safe drainage grates shall be used in the construction of all residential streets.

Administrative correction.
 See: 29 N.J.R. 1296(a).
 Amended by R.2000 d.480, effective December 4, 2000 (operative June 3, 2001).
 See: 32 N.J.R. 2670(b), 32 N.J.R. 4277(a).
 Rewrote (b)1.
 Amended by R.2002 d.399, effective December 16, 2002.
 See: 34 N.J.R. 2615(a), 34 N.J.R. 4412(a).
 In (a)2, substituted "Class B concrete" for "Class C concrete" and substituted "4,500 p.s.i." for "4,000 p.s.i."

5:21-4.19 Street grade, intersections, pavement, and lighting construction standards

- (a) The following apply to street grade:
1. Minimum street grade permitted for all streets shall be 0.5 percent.
 2. Maximum street grade shall vary by road hierarchy with flatter grades required for roads with higher ADTs, in accordance with the requirements shown in Table 4.6. Where terrain makes it necessary, the allowable maximum grade may be increased by up to two percent, but shall not exceed a maximum grade of 16 percent.
- (b) The following shall apply to intersections:
1. Street intersections shall be as nearly at right angles as possible and in no case shall be less than 75 degrees.
 2. New intersections along one side of an existing street shall, if possible, coincide with an existing intersection on the opposite of each street. Where provided, offsets shall be at least 150 feet between right-of-way centerlines.
 3. Intersections shall be rounded at the curbline with the street having the highest radius requirement, as shown in Table 4.6 below, determining the minimum standard for all curbines.
 4. Intersections shall be designed with a flat grade wherever practical.
 5. The minimum centerline radius, minimum tangent length between reverse curves, and curb radii shall be as shown in Table 4.6 below.
 6. Sight triangles shall be in accordance with 1990 AASHTO's "A Policy on Geometric Design of Highways and Streets" standards and based on the speed limits established by the government agency having jurisdiction. Sight triangle easements shall be required and shall include the area on each street corner that is bounded by the line which connects the sight or "connecting" points located on each of the right-of-way lines of the intersecting street. The planting of trees or other plantings, or the location of structures exceeding 30 inches in height that would obstruct the clear sight across the area of the easements, shall be prohibited, and a public right-of-entry shall be reserved for the purpose of removing any object, material or otherwise, that obstructs the clear sight.

TABLE 4.6
 STREET GRADE AND INTERSECTION DESIGN CRITERIA
 Street Hierarchy

	Special purpose street: <u>alley</u>	Special purpose street: <u>cul-de-sac</u>	Rural, residential access, and <u>neighborhood</u>	Minor <u>collector</u>	Major <u>collector</u>
Minimum Grade	0.5%	0.5%	0.5%	0.5%	0.5%
Maximum Grade	15%	12%	12%	10%	8%

	Special purpose street: alley	Special purpose street: cul-de-sac	Rural, residential access, and neighborhood	Minor collector	Major collector
Maximum Grade of Secondary Street within 50 feet of Intersection†	5%	5%	5%	5%	5%
Minimum Center-Line Radius	100 ft	100 ft	100 ft	150 ft	300 ft
Minimum Tangent Length between Reverse Curves	0 ft	50 ft	50 ft	100 ft	150 ft
Curb Radii	20 ft	25 ft	25 ft	30 ft	35 ft

Note: †As measured from the nearest right-of-way line.

(c) Pavement shall be designed using either Figures 4.2 through 4.5, the structural number method, or the alternate pavement design methods referenced in (c)3 below.

1. Pavement design using figures: Pavement design for special-purpose streets (cul-de-sac, rural, etc.), residential access, neighborhood, minor collector, and major collector shall follow the specifications shown in Figures 4.2 through 4.5 based on the street type. Subgrade categories are shown in Table 4.7 below.

2. Structural number method: As an alternative to using Figures 4.2 through 4.5, applicants may design pavement using the structural numbers found in Table 4.9 below.

i. The designated structural number must be achieved by choosing the appropriate layers of bituminous stabilized surface course (Mix I-4, Mix I-5), bituminous stabilized base course (Mix I-2, stone mix), bituminous stabilized base course (Mix I-2, gravel mix), dense graded aggregate base course, soil aggregate base course, and subbase. The structural values and minimum layer thicknesses for the various materials are listed in Table 4.8 below.

TABLE 4.8

PER-INCH STRUCTURAL VALUE FOR VARIOUS PAVING MATERIALS

Layer material	Structural value per-inch thickness	Minimum thickness
Bituminous stabilized concrete surface (Mix I-4, Mix I-5) ¹	0.44	2 inches
Bituminous stabilized base course (Mix I-2, stone mix) ²	0.44	3 inches
Bituminous stabilized base course (Mix I-2, gravel mix) ²	0.37	3 inches
Dense graded aggregate base course ²	0.14	4 inches
Soil aggregate base course ²	0.11	4 inches
Subbase	0.08	6 inches

Notes:
¹ Materials for asphalt concrete surface shall conform to Section 404.02 of the New Jersey Department of Transportation's Standard Specification for Road and Bridge Construction (1989).
² Materials for asphalt concrete base shall conform to Sections 301.02 and 304.02 of the New Jersey Department of Transportation's Standard Specification for Road and Bridge Construction (1989).

ii. Thicknesses shall be provided in 0.5 inch increments.

TABLE 4.9

STRUCTURAL NUMBER VALUES AS A FUNCTION OF ADT AND M_r¹

Maximum ADT ²	SN ₀ prior to two-inch asphalt concrete surface course		
	M _r = 3,000 psi Poor Subgrade	M _r = 5,000 psi Medium Subgrade	M _r = 7,500 psi Good/Excellent Subgrade
200	1.60	1.15	0.84
250	1.69	1.23	0.91
500	1.99	1.49	1.14
750	2.17	1.65	1.29
1,000	2.31	1.77	1.40

1,250	2.42	1.87	1.48
1,500	2.52	1.95	1.55
1,750	2.60	2.02	1.61
2,000	2.67	2.08	1.67
2,250	2.73	2.13	1.72
2,500	2.79	2.18	1.76
2,750	2.84	2.23	1.80
3,000	2.89	2.27	1.84
3,250	2.93	2.31	1.88
3,500	2.97	2.35	1.91
3,750	3.17	2.52	2.06
4,000	3.21	2.55	2.09
4,250	3.24	2.58	2.12
4,500	3.28	2.61	2.15
4,750	3.31	2.64	2.17
5,000	3.34	2.67	2.20
5,250	3.37	2.69	2.22
5,500	3.40	2.72	2.24
5,750	3.42	2.74	2.26
6,000	3.45	2.76	2.28
6,250	3.48	2.79	2.30
6,500	3.50	2.81	2.32
6,750	3.52	2.83	2.34
7,000	3.55	2.85	2.36
7,250	3.57	2.87	2.38
7,500	3.59	2.89	2.39

Notes:

¹ All subgrades shall be considered "poor," unless the applicant proves otherwise through CBR testing or field evaluation of soil classification. Test results shall be reviewed by the municipal engineer.

² ADT ranges for street types listed in the standards are as follows:

Rural Residential Lane	0-200
Cul-de-sac	0-250
Rural Street	0-500
Alley	0-500
Multifamily Access Cul-de-sac	0-1,000
Residential Access	0-1,500
Residential Neighborhood	0-1,500
Minor Collector	1,501-3,500
Major Collector	3,501-7,500

Source: The Table is derived from the AASHTO Guide for Design of Pavement Structures (1993).

3. Alternate pavement design: Alternate pavement design shall be allowed provided it conforms with one of the following: AASHTO Method of Flexible Pavement Design, AASHTO Method of Rigid Pavement Design, Fatigue Strength Method of Design, Multilayer Elastic Anal-

ysis, or the National Crushed Stone Association Design, incorporated herein by reference.

(d) Lighting (Reserved)

Figure 4.2
Pavement Sections for Rural Residential Lanes, Rural Streets, Cul-de-Sacs, and Alleys
 (ADT \leq 500) (EAL \leq 30,000)

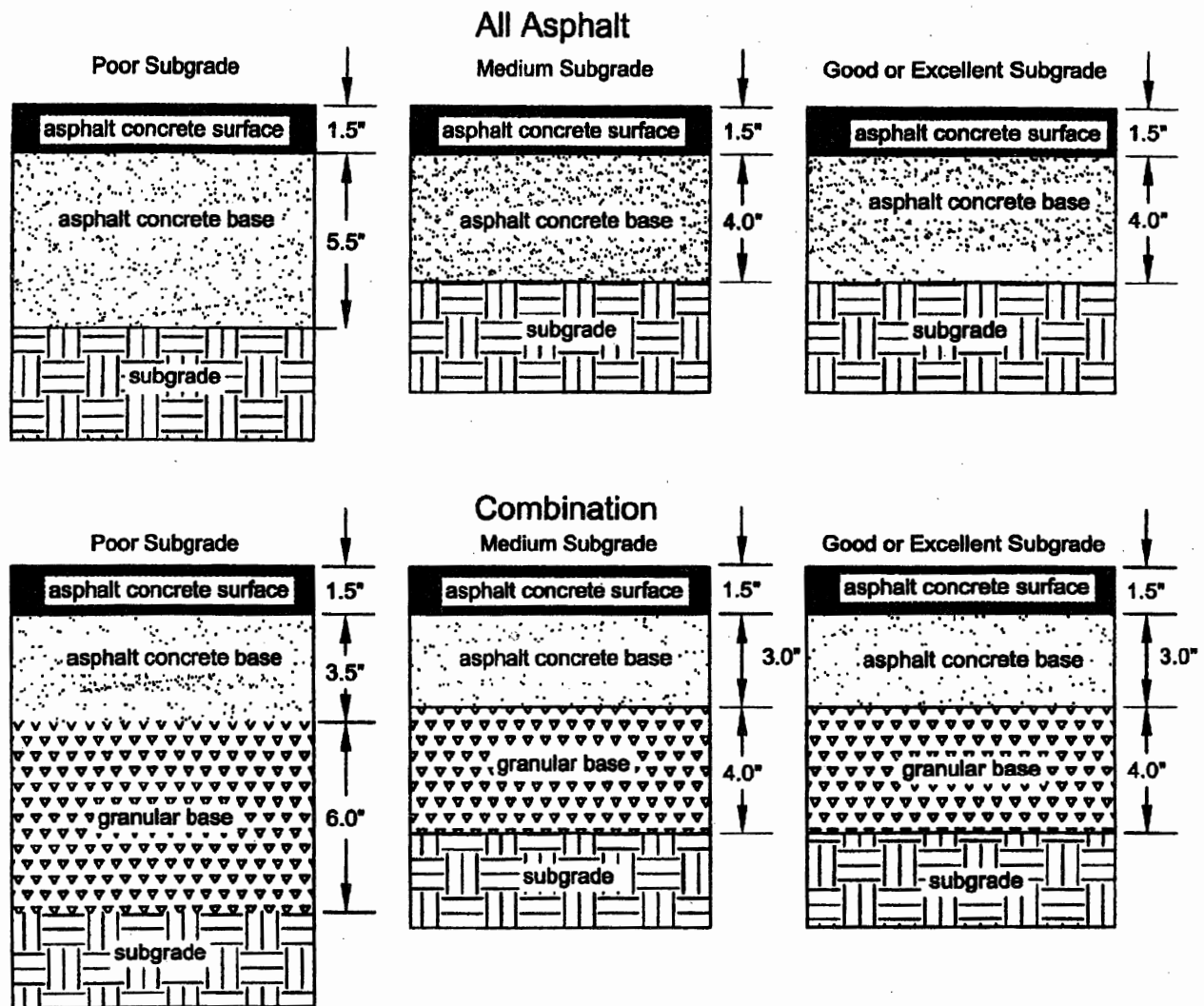

Source: N.J.S.M.E., *Asphalt Handbook for County and Municipal Engineers*, 3rd Edition, March 2000. The figures were derived by applying the Asphalt Institute's *Thickness Design - Full Depth Asphalt Pavement Structures for Highways and Streets*.

NOTES:

1. Materials for the asphalt concrete surface shall conform to Section 404.02 of the New Jersey Department of Transportation's *Standard Specifications for Road and Bridge Construction* (1989).
2. Materials for the asphalt concrete base shall conform to Sections 301.02 and 304.02 of the N.J. Department of Transportation's *Standard Specifications for Road and Bridge Construction* (1989).
3. Thicknesses may have to be constructed in multiple lifts, based on equipment capabilities.
4. The granular base shall be dense graded aggregate conforming to Section 901.08 or soil aggregate designated I-5 conforming to Section 901.09 and shown in Table 901-2 of the N.J. Department of Transportation's *Standard Specifications for Road and Bridge Construction* (1989).
5. All subgrades shall be considered "poor," unless the applicant proves otherwise through CBR testing or field evaluation of soil classification. Test results shall be reviewed by the municipal engineer.
6. Subgrade compaction shall be approved by the municipal engineer.
7. Drawings are based on the following design assumptions: A 20-year design period with staged construction is used. Base courses are designed to withstand the construction traffic anticipated during a 3-year construction period and have a residual life of 17 years at the end of the 3-year period. The entire pavement section, base course plus finish course, is designed to withstand the traffic loading for the remaining 17 years of the 20-year design period.

Figure 4.3
Pavement Sections for Residential Access and Neighborhood Streets
(ADT ≤ 1,500)(EAL ≤ 80,000)

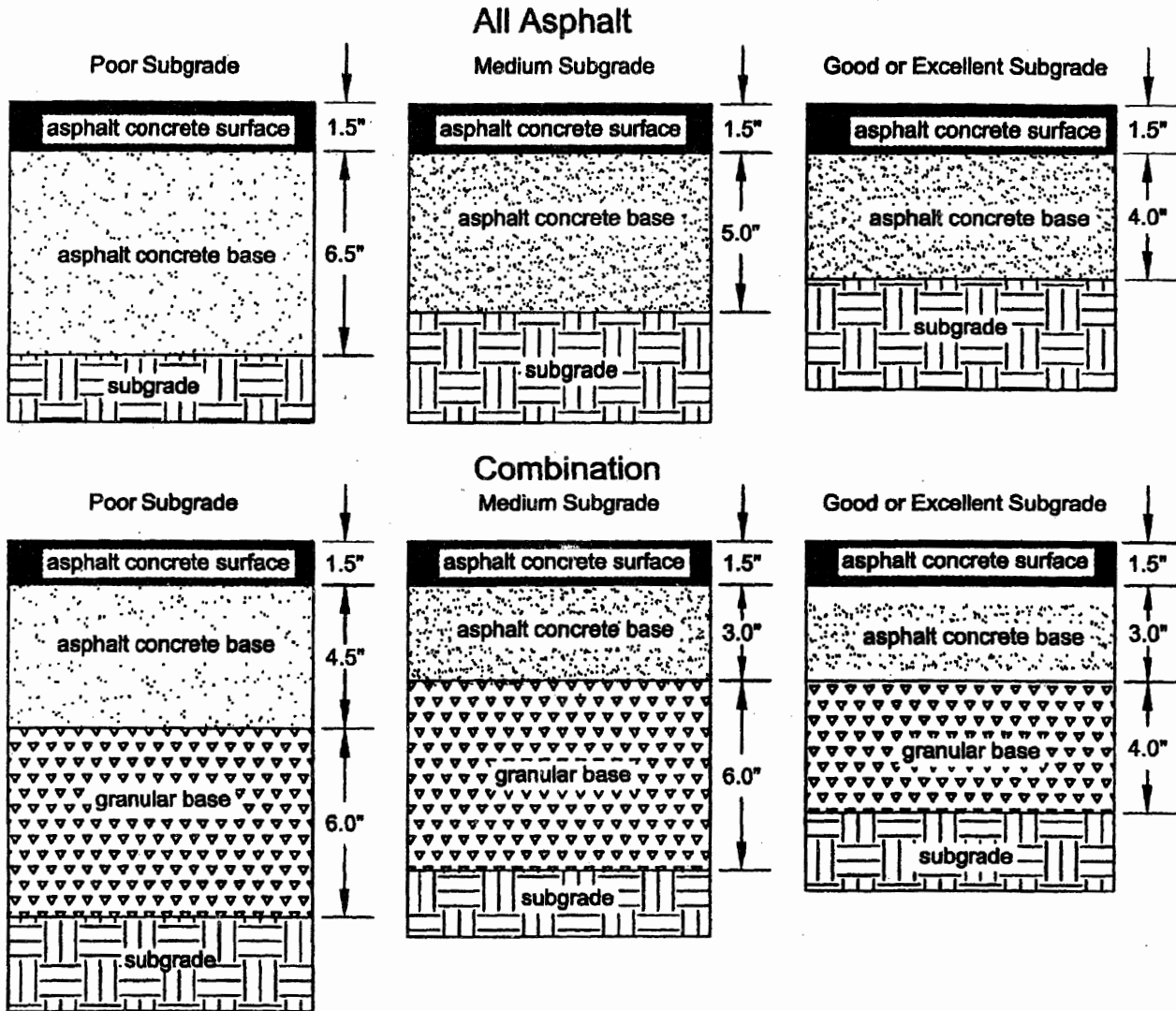

Source: N.J.S.M.E., *Asphalt Handbook for County and Municipal Engineers*, 3rd Edition, March 2000. The figures were derived by applying the Asphalt Institute's *Thickness Design - Full Depth Asphalt Pavement Structures for Highways and Streets*.

NOTES:

1. Materials for the asphalt concrete surface shall conform to Section 404.02 of the New Jersey Department of Transportation's *Standard Specifications for Road and Bridge Construction* (1989).
2. Materials for the asphalt concrete base shall conform to Sections 301.02 and 304.02 of the N.J. Department of Transportation's *Standard Specifications for Road and Bridge Construction* (1989).
3. Thicknesses may have to be constructed in multiple lifts, based on equipment capabilities.
4. The granular base shall be dense graded aggregate conforming to Section 901.08 or soil aggregate designated I-5 conforming to Section 901.09 and shown in Table 901-2 of the N.J. Department of Transportation's *Standard Specifications for Road and Bridge Construction* (1989).
5. All subgrades shall be considered "poor," unless the applicant proves otherwise through CBR testing or field evaluation of soil classification. Test results shall be reviewed by the municipal engineer.
6. Subgrade compaction shall be approved by the municipal engineer.
7. Drawings are based on the following design assumptions: A 20-year design period with staged construction is used. Base courses are designed to withstand the construction traffic anticipated during a 3-year construction period and have a residual life of 17 years at the end of the 3-year period. The entire pavement section, base course plus finish course, is designed to withstand the traffic loading for the remaining 17 years of the 20-year design period.

Figure 4.4
Pavement Sections for Minor Collectors (ADT ≤ 3,500) (EAL ≤ 200,000)

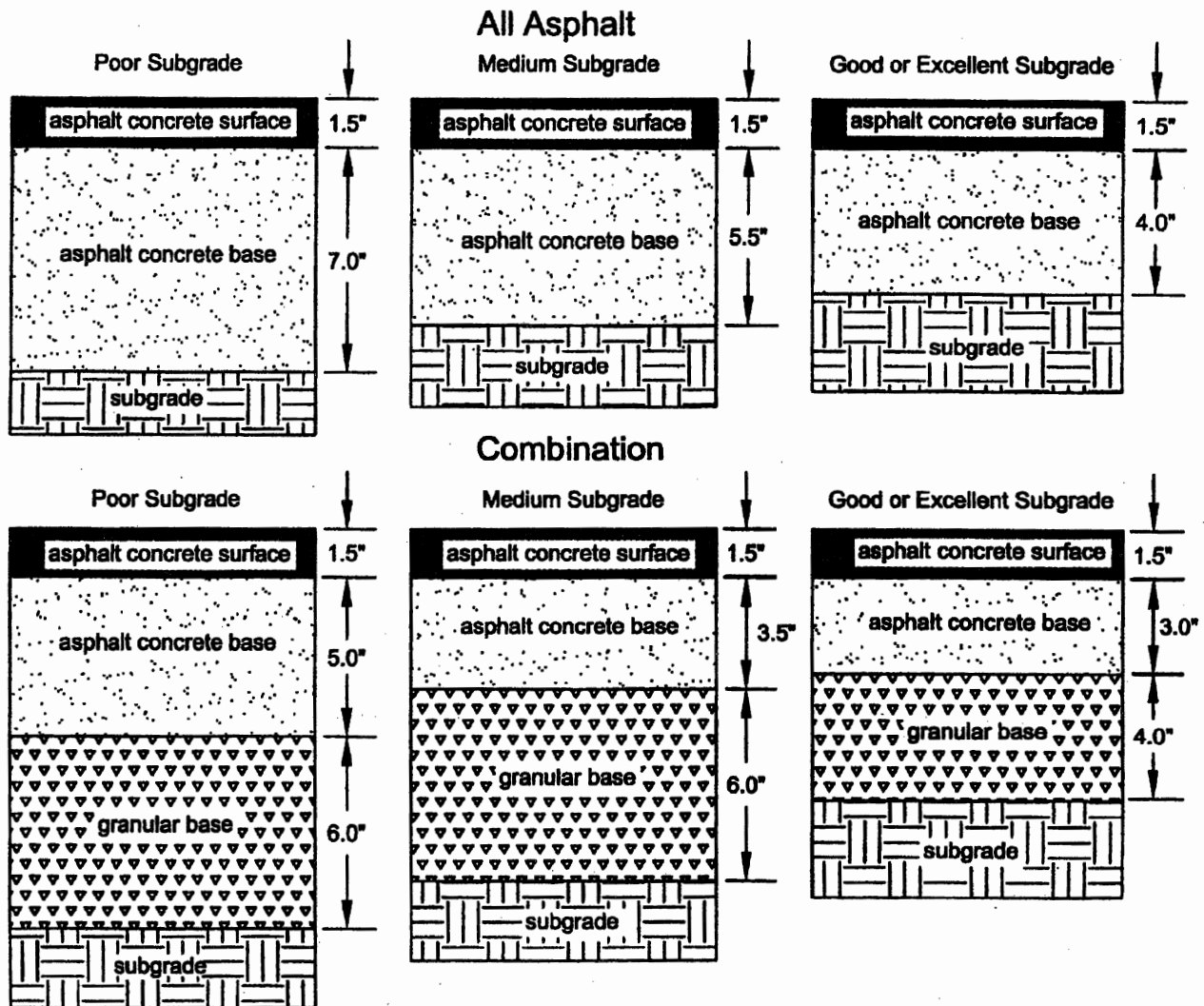

Source: N.J.S.M.E., *Asphalt Handbook for County and Municipal Engineers*, 3rd Edition, March 2000. The figures were derived by applying the Asphalt Institute's *Thickness Design - Full Depth Asphalt Pavement Structures for Highways and Streets*.

NOTES:

1. Materials for the asphalt concrete surface shall conform to Section 404.02 of the New Jersey Department of Transportation's *Standard Specifications for Road and Bridge Construction* (1989).
2. Materials for the asphalt concrete base shall conform to Sections 301.02 and 304.02 of the N.J. Department of Transportation's *Standard Specifications for Road and Bridge Construction* (1989).
3. Thicknesses may have to be constructed in multiple lifts, based on equipment capabilities.
4. The granular base shall be dense graded aggregate conforming to Section 901.08 or soil aggregate designated I-5 conforming to Section 901.09 and shown in Table 901-2 of the N.J. Department of Transportation's *Standard Specifications for Road and Bridge Construction* (1989).
5. All subgrades shall be considered "poor," unless the applicant proves otherwise through CBR testing or field evaluation of soil classification. Test results shall be reviewed by the municipal engineer.
6. Subgrade compaction shall be approved by the municipal engineer.
7. Drawings are based on the following design assumptions: A 20-year design period with staged construction is used. Base courses are designed to withstand the construction traffic anticipated during a 3-year construction period and have a residual life of 17 years at the end of the 3-year period. The entire pavement section, base course plus finish course, is designed to withstand the traffic loading for the remaining 17 years of the 20-year design period.

Figure 4.5
Pavement Sections for Major Collectors (ADT ≤ 7,500) (EAL ≤ 400,000)

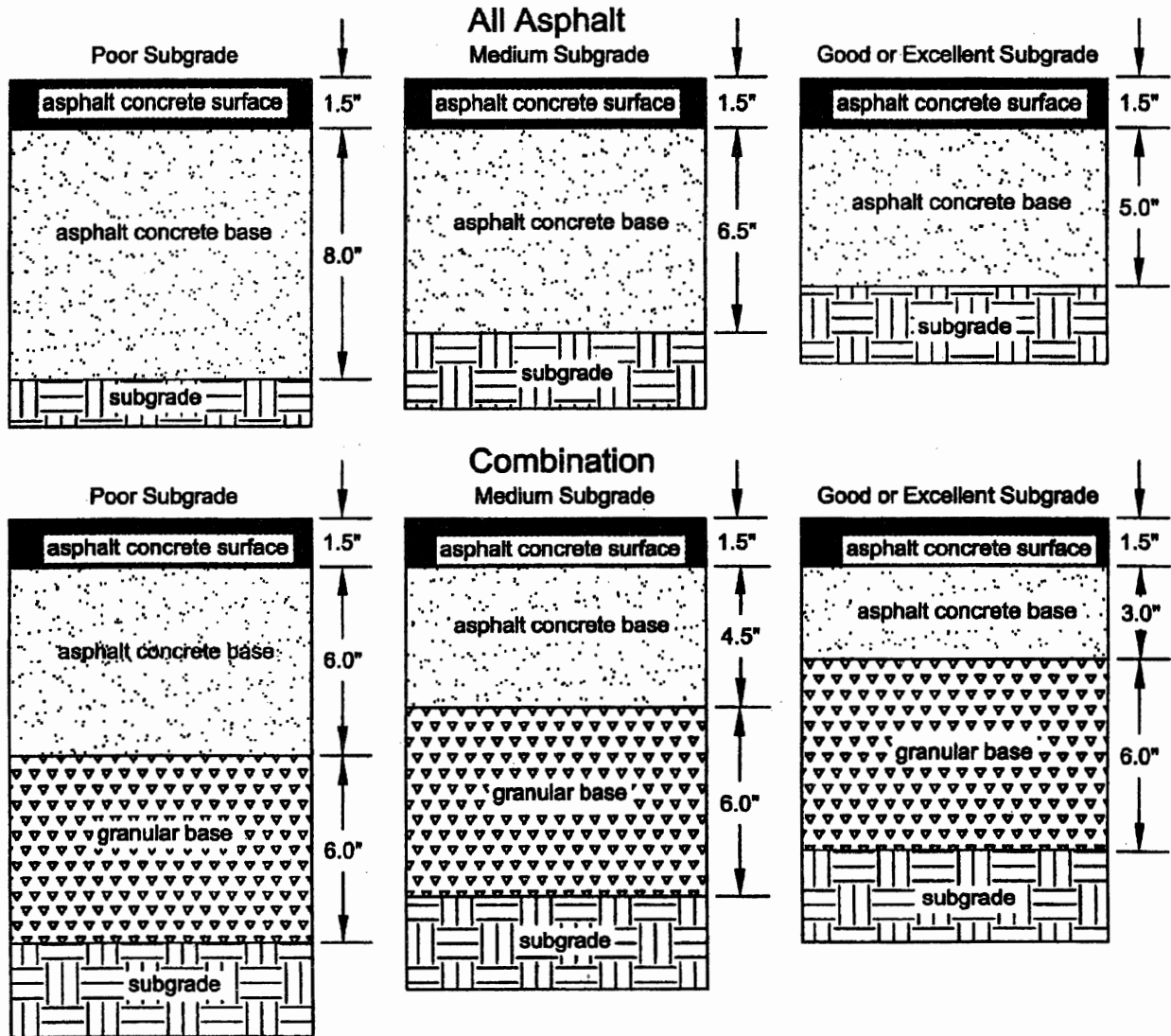

Source: N.J.S.M.E., *Asphalt Handbook for County and Municipal Engineers*, 3rd Edition, March 2000. The figures were derived by applying the Asphalt Institute's *Thickness Design - Full Depth Asphalt Pavement Structures for Highways and Streets*.

NOTES:

1. Materials for the asphalt concrete surface shall conform to Section 404.02 of the New Jersey Department of Transportation's *Standard Specifications for Road and Bridge Construction* (1989).
2. Materials for the asphalt concrete base shall conform to Sections 301.02 and 304.02 of the N.J. Department of Transportation's *Standard Specification for Road and Bridge Construction* (1989).
3. Thicknesses may have to be constructed in multiple lifts, based on equipment capabilities.
4. The granular base shall be dense graded aggregate conforming to Section 901.08 or soil aggregate designated I-5 conforming to Section 901.09 and shown in Table 901-2 of the N.J. Department of Transportation's *Standard Specifications for Road and Bridge Construction* (1989).
5. All subgrades shall be considered "poor," unless the applicant proves otherwise through CBR testing or field evaluation of soil classification. Test results shall be reviewed by the municipal engineer.
6. Subgrade compaction shall be approved by the municipal engineer.
7. Drawings are based on the following design assumptions: A 20-year design period with staged construction is used. Base courses are designed to withstand the construction traffic anticipated during a 3-year construction period and have a residual life of 17 years at the end of the 3-year period. The entire pavement section, base course plus finish course, is designed to withstand the traffic loading for the remaining 17 years of the 20-year design period.

TABLE 4.7
SUBGRADE CATEGORIES
A. BASED ON STRENGTH TEST

Subgrade category	California Bearing Ratio (Cbr)	Resilient Modules Mr Value
Good to excellent	+ 10	Above 15,000
Medium	+ 5 to 9	7,500 to 13,500
Poor	2 to 4	3,000 to 6,000

B. BASED ON SOIL CLASSIFICATION

Subgrade category	Material	Unified System ^a	AASHTO System ^a
Good to excellent	Gravels and sands	GW, GP, GM, GC, SW, SP, SM, SC	A-1, A-2-4, A-2-5, A-2-6, A-2-7, A-3
Good or poor	Silts and clays	ML, CL, OL, MH, CH, OH	A-4, A-5, A-6, A-7-5, A-7-6

Notes: ^aRefers to categories of soil types and properties

Sources: Per the Rutgers Model Subdivision and Site Plan Ordinance by David Listokin and Carole W. Baker, January 1987—Original strength test and soil classification information derived from the Asphalt Institute, "Thickness Design—Full-Depth Asphalt Pavement Structures for Highways and Streets," MS-1, 8th Edition, August 1970 in Robert F. Baker et al. (editor), Handbook of Highway Engineering. Inclusion of SW, SP, SC soil classifications based on information from the Portland Cement Association's Thickness Design for Concrete Highway and Street Pavements.

Revised CBR strength test and M_r value information are from the Asphalt Handbook for County and Municipal Engineers, November 1991 (Second Edition), published by the New Jersey Society of Municipal Engineers.

Administrative correction.

See: 29 N.J.R. 1296(a).

Administrative correction.

See: 29 N.J.R. 2816(a).

Amended by R.1999 d.374, effective November 1, 1999 (operative May 1, 2000).

See: 31 N.J.R. 477(a), 31 N.J.R. 3259(a).

Rewrote (b)2; and in Table 4.6, deleted Intersection Standard heading, and substituted a reference to Maximum Grade of Secondary Street for a reference to Maximum Grade.

Amended by R.2000 d.480, effective December 4, 2000 (operative June 3, 2001).

See: 32 N.J.R. 2670(b), 32 N.J.R. 4277(a).

Rewrote (c); amended Figures 4.2 and 4.3; and inserted Figures 4.4 and 4.5.

Amended by R.2002 d.399, effective December 16, 2002.

See: 34 N.J.R. 2615(a), 34 N.J.R. 4412(a).

Added new (c), including Tables 4.8 and 4.9; deleted former (c); recodified former (d) as new (c)3; added new Figures 4.2 through 4.5 and deleted former Figures 4.2 through 4.5.

(b) Sight easements on vertical and horizontal curves shall be required and determined based on the sight distance requirements contained in the 1990 AASHTO's "A Policy on Geometric Design of Highways and Streets" standards, taking into consideration the speed limits established by the government agency having jurisdiction. Residential access, residential neighborhood, and rural street design shall be based on a speed limit of 25 miles an hour. Minor collector street design shall be based on a speed limit of 30 miles per hour. Major collector design shall be based on a speed limit of 30 miles per hour or five miles over the anticipated posted speed limit, whichever is higher.

Amended by R.2000 d.480, effective December 4, 2000 (operative June 3, 2001).

See: 32 N.J.R. 2670(b), 32 N.J.R. 4277(a).

In (b), substituted "shall" for "should" in the second and third sentences, deleted "and major" following "Minor" in the third sentence, and the last sentence was added.

5:21-4.20 Curves

(a) Vertical and horizontal curves shall be designed in accordance with 1990 AASHTO's "A Policy on Geometric Design of Highways and Streets" standards, incorporated herein by reference.

SUBCHAPTER 5. WATER SUPPLY

5:21-5.1 Water supply system

Water supply systems, where installed, shall conform to the standards contained in this subchapter.

5:21-5.2 Capacity

(a) The water supply system shall be adequate to handle the necessary flow, based on complete development of the tract.

(b) When plans for future development necessitate over-sizing of the water supply system, the municipality or utility authority may enter into an agreement with the developer to address the fair share of the costs.

(c) The demand rates for all uses shall be considered in computing the total system demand. Where fire protection is provided in accordance with (e) below, the system shall be capable of providing the required fire demand plus the required maximum daily residential demand, or the peak hour flows indicated in Table 5.2 below, whichever is greater. The maximum daily demand shall be calculated by multiplying the average daily residential demand indicated in Table 5.1 by a factor of 1.5.

(d) Average daily residential consumption shall be computed in accordance with the housing unit type and size data shown in Table 5.1. The peak daily flows shall be computed by applying a peaking factor of three times the average daily residential consumption. The municipality may require deviations in the peaking factor value provided appropriate documentation and justification for the deviation from the standards is provided.

(e) The design of the on-site water distribution system shall be adequate to provide fire protection as per ISO standard, *Fire Suppression Rating Schedule*, or per AWWA M31, "Manual of Water Supply Practices—Distribution System Requirements for Fire Protection," ISO method on pages 3-9, incorporated herein by reference.

TABLE 5.1
WATER DEMAND/GENERATION BY
TYPE /SIZE OF HOUSING

Type/size housing	Number of residents	Residential Water Demand ^a (daily) (gallons per day)
Single-family detached		
2 bedroom	2.13	215
3 bedroom	3.21	320
4 bedroom	3.93	395
5 bedroom	4.73	475
Garden Apartment		
1 bedroom	1.57	120
2 bedroom	2.33	175
3 bedroom	3.56	270
Townhouse		
1 bedroom	1.69	125
2 bedroom	2.02	150
3 bedroom	2.83	210
4 bedroom	3.67	275
High-rise		
studio	1.07	80
1 bedroom	1.34	100
2 bedroom	2.14	160

Type/size housing	Number of residents	Residential Water Demand ^a (daily) (gallons per day)
Mobile home		
1 bedroom	1.73	130
2 bedroom	2.01	150
3 bedroom	3.47	260

Notes: ^a Based on 100 gallons per person per day for single-family detached units and 75 gallons per person per day for other housing types (rounded).

Source: U.S. Census, Public Use File—New Jersey (Units built 1975-1980).

TABLE 5.2
DESIGN STANDARDS FOR PEAK HOUR FLOW

Total houses served	Peak hourly rates (gallons per minute per house)
5	8.0
10	5.0
50	3.0
100	2.0
250	1.3
500	0.8
750	0.7
1,000 or more	0.6

Amended by R.1999 d.374, effective November 1, 1999 (operative May 1, 2000).

See: 31 N.J.R. 477(a), 31 N.J.R. 3259(a).

Rewrote (c); and in Table 5.2, added Peak Hourly Rate for 1,000 or more Total Houses Served.

5:21-5.3 System design and placement

(a) System design and placement shall comply with the following construction specifications, incorporated herein by reference: all applicable NJ Department of Environmental Protection (NJDEP) rules, the American Water Works Association (AWWA) standards, and in the Pinelands Area, the Standards of the Pinelands Comprehensive Management Plan, with the strictest standards governing.

(b) Distribution mains of the overall system shall be connected into loops so that the supply may be brought to the consumer from more than one direction. In balancing loops in a design, the Hardy-Cross, or an equivalent, method shall be used (see subchapter Appendix, incorporated herein by reference). Manning roughness coefficients listed in Table 7.1 in N.J.A.C. 5:21-7.1 may be used in these calculations. Dead-end lines shall be permitted within the design of a looped system provided that there are no more than 20 dwelling units permanently, or no more than 50 dwelling units temporarily, on a dead-end line. When dead-end lines are used, they shall be provided with a hydrant or blowoff at the terminus as a means of flushing.

(c) Valves, except on a permitted dead end, shall be located on distribution mains so that no more than one hydrant would be out of service as a result of a single water main break. They shall be located in all small branches off

larger mains; and where eight-inch or larger mains lines intersect, a valve shall be located in each branch. At street intersections, valves shall be located near pipe intersections for ease in finding in the event of a water main break.

(d) In addition to the above requirements, water mains shall be valved so that not more than one-fifth of a mile would be affected by a single water main break. Geared valves on 16-inch mains or larger shall be furnished when required by the municipality.

iii. Twenty-five-year storm for culvert design where the culvert will be located in streams shown as a blue line on the New Jersey State Atlas or the United States Coast and Geodetic Survey maps. Culverts with an upstream drainage area of 50 acres or more shall be designed to accommodate a 100-year frequency storm in accordance with Flood Hazard Area Control Regulations, N.J.A.C. 7:13-2.16.

iv. Twenty-five-year storms for open channels where the upstream drainage area is less than 50 acres. When the upstream drainage area is 50 acres or more, design engineers shall design open channels to accommodate the 100-year storm, in accordance with Flood Hazard Area Control Regulations, N.J.A.C. 7:13-2.16.

5. The size of the drainage area shall include onsite and offsite lands contributing to the design point.

6. Computer software adaptations of the Rational Method or the S.C.S. TR-55 are acceptable, provided their data and graphic printout allow review and evaluation.

(d) Design engineers shall use a consistent method to calculate peak rate of runoff and volume when computing runoff hydrographs. If either TR-55, TR-20, or HEC-1 is used to calculate peak rate of runoff, then the same method shall be used to determine volume. If the rational method is used for peak flow calculations, the design engineer shall use the Modified Rational method to calculate peak volume to be used for basin routing. A maximum drainage area of 20 acres shall be used for the Modified Rational Method.

Administrative correction.
 See: 29 N.J.R. 1296(a).
 Amended by R.1999 d.374, effective November 1, 1999 (operative May 1, 2000).
 See: 31 N.J.R. 477(a), 31 N.J.R. 3259(a).
 In (b), substituted "size" for "necessity for, and sizing" in the second sentence; in (c), added a third sentence in 2i, and inserted new third and fourth sentences in the introductory paragraph of 4; in (d), inserted "when computing runoff hydrographs" at the end of the first sentence; and in Table 7.1, added a reference to Minor Streams.
 Administrative correction.
 See: 32 N.J.R. 684(b).

5:21-7.3 Runoff collection system design

(a) Design engineers shall determine pipe size based on design runoff, conduit entrance conditions, and hydraulic capacity.

(b) In general, no pipe size in the storm drainage system shall be less than 15 inches in diameter. Design engineers may use a 12-inch diameter pipe as a cross-drain to a single inlet. Design engineers shall use the Manning equation to determine hydraulic capacity of pipes.

(c) All discharge pipes shall terminate with an appropriate precast concrete or flared-end section or concrete head-wall with or without wingwalls, as conditions require. Design engineers shall consider such site conditions as slope,

soil stability, vegetation, grade, and size of conduit to determine whether or not to use wingwalls.

(d) Materials used in the construction of storm sewers shall be constructed of reinforced concrete, ductile iron, or corrugated polyethylene, or, when approved by the municipal engineer, corrugated metal. The most cost-effective materials shall be permitted that conform to local site conditions and reflect the relevant operations, maintenance, and system character of the municipal stormwater system. Specifications referred to, such as ASTM or AWWA, shall be the latest revision in effect at the time of application.

1. The following apply to reinforced concrete pipe:
 - i. Circular reinforced concrete pipe and fittings shall meet the requirements of ASTM C76.
 - ii. Elliptical reinforced concrete pipe shall meet the requirements of ASTM C507.
 - iii. Joint design and joint material for circular pipe shall conform to ASTM C443.
 - iv. Joints for elliptical pipe shall be bell and spigot or tongue and groove sealed with butyl, rubber tape, rubber ring gaskets, or external sealing bands conforming to ASTM C877.
 - v. All pipe shall be Class III, minimum unless loading conditions call for stronger pipe (that is, higher class).
 - vi. The minimum depth of cover over the concrete pipe shall be as designated by the American Concrete Pipe Association in Table 7.4 below as follows.

TABLE 7.4

MINIMUM DEPTH OF COVERAGE OVER CONCRETE PIPE

Pipe Diameter (in inches)	ASTM Class Pipe	Minimum Cover (surface to top of pipe in inches)
12	III	17
	IV	12
	V	7
15	III	16
	IV	11
	V	7
18	III	16
	IV	10
	V	6
24	III	15
	IV	6
	V	6
30	III	10
	IV	6
	V	6

Pipe Diameter (in inches)	ASTM Class Pipe	Minimum Cover (surface to top of pipe in inches)
36 & above	III	6
	IV	6

Minimum depth of coverage as designated by the American Concrete Pipe Association.

vii. Minimum depth of cover standards for ductile iron and corrugated polyethylene pipe shall conform to manufacturer standards.

2. Ductile iron pipe shall conform to ANSI/AWWA C151/A21.51. Joints shall conform to ANSI/AWWA C111/A21.11 or ANSI/AWWA C115/A21.15 as appropriate. Pipe shall be designed in accordance with ANSI/AWWA C150/A21.50. The outside of the pipe shall be coated in accordance with ANSI/AWWA C151/A21.51, and the inside lined in accordance with ANSI/AWWA C104/A21.4. Ductile iron pipe shall be installed in accordance with AWWA C600.

3. Corrugated polyethylene pipe shall conform to AASHTO M252 for three through 10 inches and AASHTO M294 for sizes 12 inches and larger. All pipes greater than 12 inches in diameter shall be Type S, unless conditions dictate otherwise. Materials shall conform to ASTM D3350, "Standard Specification for Polyethylene Plastics Pipe and Fittings Materials." Pipe joints and fittings shall be compatible with the pipe material and shall conform to the same standards and specifications as the pipe material. Pipe couplers shall not cover less than one full corrugation on each section of pipe. Installation shall be in accordance with ASTM D2321, "Practice for Underground Installation of Thermoplastic Pipe for Sewers and Other Gravity-Flow Applications." Backfill material shall be placed in six-inch lifts and compacted to 95 percent minimum dry density, per AASHTO T99. In areas of high groundwater tables, design engineers shall check for flotation.

4. Corrugated metal pipe, when approved by the municipal engineer, shall meet the requirements and be installed in the manner specified in the subchapter appendix.

(e) Pipe bedding and backfill shall be provided as specified in *Design and Construction of Urban Stormwater Management Systems*, ASCE Manuals and Reports of Engineering Practice No. 77, 1993, incorporated herein by reference. Bedding and backfill for any pipe material not covered by this manual shall be installed in accordance with manufacturer's recommendations. The municipal engineer may require the developer to provide professional certification as to the suitability of backfill material and where such suitability does not exist, any modifications needed to use on-site material and the appropriate methods to install this material. The municipal and/or utility engineer shall rely on this certification.

(f) No pipe shall be placed on private property unless the owner of the land is to own or operate the pipe, or an easement deeded to the municipality is obtained. All easements shall be a minimum of 20-foot wide unless depth of pipe, soil conditions, or additional utilities require wider. Where the easement is located adjacent to a right-of-way, the municipality may approve a narrower easement.

Amended by R.1999 d.374, effective November 1, 1999 (operative May 1, 2000).

See: 31 N.J.R. 477(a), 31 N.J.R. 3259(a).

In (d), inserted a reference to Table 7.4 in 1vi, rewrote 2, and rewrote the first sentence in 3.

Amended by R.2000 d.480, effective December 4, 2000 (operative June 3, 2001).

See: 32 N.J.R. 2670(b), 32 N.J.R. 4277(a).

Rewrote (f).

5:21-7.4 Inlets, catch basins, manholes, and outlets

(a) Design engineers shall design inlets, catch basins, and manholes in accordance with the New Jersey Department of Transportation's *Standard Specifications for Road and Bridge Construction* (1989). Design engineers shall use bicycle-safe grates. For Type A inlets, they should use a frame and single grate. Type B inlets require a frame, grate, and curb-type inlet with back piece. Type E inlets require a frame and double grate.

(b) Inlet spacing depends on the inlet capacity. Maximum gutter line flow is 400 feet. The maximum capacity of a curb inlet shall be six cubic feet per second. Area inlets in parking lots should be limited to three cubic feet per second.

(c) Manholes shall be precast concrete or concrete block coated with two coats of portland cement mortar outside the manhole. Masonry brick may be used to make vertical adjustment to rims, as long as the adjustments are 12 inches or less. In acidic soils, all manholes shall have two coats of black bitumastic waterproofing applied per manufacturer's instruction.

(d) If precast manhole barrels and cones are used, they shall conform to ASTM Specification C478, with round rubber gasketed joints, conforming to ASTM Specification C923. Both ASTM Specifications are incorporated herein by reference. Maximum absorption shall be eight percent in accordance with ASTM Specification C478, method A.

(e) If precast manholes are used, the top riser section shall terminate less than one foot below the finished grade, and the manhole cover shall be flush with the finished grade.

(f) Manhole frames and covers shall be of cast iron, conforming to ASTM Specification A48, Class 30, incorporated herein by reference, and be suitable for H-20 loading capacity. Manhole covers in remote locations may have a locking device.

(g) Outlet grates, fences, and other safety features for stormwater management facilities shall conform with New Jersey Department of Environmental Protection's Stormwater Management Rules, N.J.A.C. 7:8. Safety requirements for detention basin and other stormwater facilities are incorporated in N.J.A.C. 5:21-7.5(f)6.

(h) The channel should be, insofar as possible, a smooth continuation of the pipe. The pipe may be laid through the manhole and the top half removed by saw cut. The completed channel should be U-shaped. The channel height shall be three-fourths of the diameter of the pipe.

(i) The bench should provide good footing for a workman and a place where minor tools and equipment can be laid. It must have a slope of four to eight percent.

Administrative correction.

See: 29 N.J.R. 1296(a).

Amended by R.1999 d.374, effective November 1, 1999 (operative May 1, 2000).

See: 31 N.J.R. 477(a), 31 N.J.R. 3259(a).

Amended by R.2002 d.399, effective December 16, 2002.

See: 34 N.J.R. 2615(a), 34 N.J.R. 4412(a).

In (b), in second sentence substituted "gutter line flow" for "distance between inlets".

5:21-7.5 Detention basins and other stormwater facilities

(a) Development shall use the best available technology to accommodate stormwater management by natural drainage strategies where possible and practicable. Detention facilities, when required or selected, shall be designed, constructed, and maintained according to the following standards.

(b) Design engineers shall coordinate structural detention requirements with nonstructural practices, such as cluster land-use development, open space acquisition, riparian buffers, and flood hazard controls.

(c) Detention and all other stormwater facilities shall conform to the New Jersey Department of Environmental Protection's Stormwater Management Rules, at N.J.A.C. 7:8-3.4. Design engineers shall also adhere to, when applicable, the stormwater design requirements in the following rules:

1. Coastal Zone Management Rules, N.J.A.C. 7:7E;
2. Dam Safety Standards, N.J.A.C. 7:20;
3. Soil Erosion and Sediment Control Standards, N.J.A.C. 2:90-1;
4. Flood Hazard Area Regulations, N.J.A.C. 7:13;
5. Pinelands Regulations, N.J.A.C. 7:50-6.81 through 6.88; and
6. Freshwater Wetlands Protection Act Rules, N.J.A.C. 7:7A.

(d) Where municipalities require the use of detention facilities, design engineers shall design the basins to accommodate site runoff generated from two-year, 10-year, and 100-year storms as routed to the basin, considered individually, unless the detention basin is classified as a dam, in which case the facility must comply with the Dam Safety Standards, N.J.A.C. 7:20.

1. These design storms shall be defined as either a 24-hour storm using Type III rainfall distribution when using U.S. Soil Conservation Service procedures (such as TR-20 or TR-55 tabular method), or the design storm resulting in the greatest storage volume to achieve the required outflow using a design method such as the Modified Rational Method. Runoff greater than that occurring from the 100-year, 24-hour storm will be passed over an emergency spillway.

i. A map of approximate geographic boundaries for S.C.S. rainfall distributions presented on page B-2 of the June 1986 edition of TR-55 shows all of New Jersey in the Type III region. Although the May 1982 version of TR-20 does not include a standard S.C.S. 24-hour, cumulative Type III distribution rainfall table like it does for Type I, IA, and II, there is a test version (Version 2.04TEST) of the program available from the S.C.S. which does. The Type III distribution also can be manually added to a TR-20 model by using a RAINFL table.

2. Detention facilities shall be designed to accommodate runoff from the development of the site for the two-, 10-, and 100-year storm events so that pre-development peak flow rates that impact on downstream properties, watercourses, and/or drainage systems are not increased.

3. Where there is not a regional stormwater plan, as specified below in (d)4, then the design engineer shall design detention facilities such that the post-project construction peak runoff for the two-year storm event is 50 percent of the pre-project construction peak runoff rate. The post-project construction peak runoff rates for the 10 and 100-year storm events shall be 75 and 80 percent, respectively, of the pre-project construction peak runoff rates. It should be noted that these percentages only apply to the portion of the post-project runoff from the site under development. Offsite runoff may be computed at 100 percent of the pre-project rate.

4. If a watershed stormwater management plan for the region or watershed exists, approved and adopted pursuant to the New Jersey Department of Environmental Protection rules at N.J.A.C. 7:8, then the design engineer shall design stormwater management systems to conform to that plan. For some parts of the watershed, this may mean a detention basin is unnecessary.

5. If the development site is not part of a watershed stormwater management plan, then the design engineer may model the watershed to be consistent with regulations administered by the Department of Environmental

Protection and shall design stormwater management facilities to conform to that model. This analysis shall include impacts of existing development and all potential future development in the drainage area. For some parts of the watershed, this may mean detention is unnecessary.

(e) Design engineers shall locate detention facilities (either "wet" or "dry") so as to not interfere with or adversely affect existing surface waters on the site or adjacent to the site. Excavation for detention facilities shall be designed to be the maximum practical distance above seasonally high groundwater elevation. In the case of "wet" detention facilities, storage may only be presumed to be available above the elevation of the seasonal high groundwater. If the facility is designed as an infiltration basin, the bottom of the basin shall be a minimum of two feet above the elevation of the seasonally high water table. The determination of the seasonal high water table shall be made by the applicant's engineer.

(f) The following list of general structural criteria shall be used to design stormwater detention basins.

1. Detention components: principal basin control structure (quantity control), as follows:

i. Principal basin control structures will consist of orifice and/or weir control devices. Design engineers shall design orifices based upon the following equation:

$$Q = C A (2gH)^{0.5}$$

where

Q = the flow rate in cubic feet per second

C = 0.6 (The orifice flow coefficient "C" may vary, depending on entrance conditions. Design engineers may use other coefficients with appropriate references.)

A = cross-section area of flow in square feet

H = the vertical distance in feet between the center of the orifice and the water surface

2g = 64.4 feet per second²

To minimize the chance of clogging, orifices intended solely for runoff quantity control will be at least six inches in diameter (or its equivalent). All joints are to be watertight. In addition, trash racks and/or anti-vortex devices shall be required. When weirs are used alone or in conjunction with orifices, design engineers shall use the following equation:

$$Q = C_w L(h)^{3/2}$$

where

Q = the flow rate in cubic feet per second

C_w = 3.2 (design engineers may use other coefficients with appropriate references)

L = length of the weir in feet

h = the vertical distance in feet between water surface elevation and the crest of the weir.

All weirs shall be constructed as part of a reinforced concrete structure with appropriate grates.

ii. Eight-inch-thick, anti-seep collars are to be installed along outlet pipes when required by the municipal engineer. Reinforcement steel shall be No. 5 bars at 12 inches both ways, with two inches of cover on both faces (minimum).

iii. Where necessary for stability of the outlet pipe, a concrete cradle shall be provided.

iv. All principal basin control structures shall be precast or reinforced concrete. All joints are to be watertight.

v. Suitable lining shall be placed upstream and downstream of principal basin control structures, as necessary, to prevent scour and erosion. Such lining shall conform to Standards for Soil Erosion and Sediment Control in New Jersey, N.J.A.C. 2:90, promulgated by the N.J. State Soil Conservation Committee.

2. Detention components: emergency spillways, as follows:

i. Vegetated emergency spillways shall have side slopes not exceeding three horizontal to one vertical.

ii. Maximum velocities in emergency spillways shall be checked based on the velocity of the peak flow in the spillway resulting from the routed Emergency Spillway Hydrograph. The design of the emergency spillway will be based on the 100-year inflow to the basin, except for class IV dams, which shall comply with the Dam Safety Standards, N.J.A.C. 7:20. The design of the emergency spillway assumes the principal spillway is malfunctioning and will not allow any discharge or flow. Where maximum velocities exceed those contained in Table 7.5 below, suitable lining shall be provided.

iii. Where maximum velocities exceed the allowable velocities for soil stability as determined in the Standards for Soil Erosion and Sediment Control in New Jersey, N.J.A.C. 2:90, promulgated by the N.J. State Soil Conservation Committee, suitable lining should be provided. Design engineers also may check maximum velocities in emergency spillways based on the velocity of the peak flow in the spillway resulting from the routed Emergency Spillway Hydrograph. Where maximum velocities exceed those contained in Table 7.5 below, suitable lining shall be provided. Linings shall meet specifications required in Hydraulic Engineering Circular No. 15—Design of Stable Channels with Flexible Linings, published by the U.S. Department of Transportation, Federal Highway Administration or Standards for Soil Erosion and Sediment Control in New Jersey, N.J.A.C. 2:90, promulgated by the State Soil Conservation Committee, New Jersey Department of Agriculture.

TABLE 7.5
 PERMISSIBLE VELOCITIES FOR EMERGENCY
 SPILLWAYS WITH UNIFORM STANDS FOR VARIOUS
 WELL-MAINTAINED GRASS COVERS

Ground Cover	Slope Percent	Permissible Velocities On:	
		Erosion- resistant soils (fps)	Easily eroded soils (fps)
Kentucky bluegrass	5-10	6	4
Lawn grass mixture	0-5	5	4
	5-10	4	3
Weeping lovegrass	0-5	3.5	2.5
Alfalfa			
Crabgrass			

In (f)iii, inserted "when required by the municipal engineer" in the first sentence.

5:21-7.6 Stormwater management: water quality

(a) The water quality design storm shall be defined as the one-year frequency S.C.S. Type III, 24 hour storm or 1.25 inches of rainfall falling uniformly in two hours.

(b) Where detention basins, wet basins, ponds, constructed wetlands, infiltration structures, dry wells, or other devices are used to control the quantity or rate of post-development runoff, then they shall incorporate the measures required by this section in order to protect the quality of surface and subsurface waters. The water quality design storm shall be controlled by best management practices. These include, but are not limited to, the following:

1. In "dry" detention basins, provisions shall be made to ensure that the runoff from the water quality design storm is retained such that, 18 hours following the peak storage in the basin, no more than 90 percent of the volume stored will be evacuated. The 18-hour retention time shall be reduced in any case that would require an outlet size diameter of three inches or less. Therefore, three-inch-diameter orifices shall be the minimum allowed. This minimum is only for water quality outlets. If this minimum outlet size does not allow for the detention times required, then additional techniques shall be used to remove total suspended solids.

2. In permanent ponds or "wet" basins, the water quality requirements of this ordinance shall be satisfied where the volume of permanent water is at least three times the volume of runoff produced by the water quality design storm.

3. Infiltration practices such as dry wells, infiltration basins, infiltration trenches, and buffer strips may be used to satisfy this requirement provided they produce zero runoff from the water quality design storm and allow for complete infiltration within 72 hours. Infiltration strategies shall be limited to areas where the soils are suitable to allow infiltration.

4. Suitable best management practices can be found in the following documents:

i. Stormwater and Nonpoint Source Pollution Control, Best Management Practices Manual, State of New Jersey, Department of Environmental Protection, Office of Land and Water Planning.

ii. Technical Manual for Land Use Regulation Program, Bureaus of Inland and Coastal Regulations, Stream Encroachment Permits, Revised September 1995, State of New Jersey, Department of Environmental Protection.

iii. Ocean County Demonstration Study, Stormwater Management Facilities Maintenance Manual, June 1989, State of New Jersey, Department of Environmental Protection, Office of Land and Water Planning.

iv. Any watershed stormwater management plan.

Amended by R.1999 d.374, effective November 1, 1999 (operative May 1, 2000).

See: 31 N.J.R. 477(a), 31 N.J.R. 3259(a).

Rewrote the section.

Amended by R.2002 d.399, effective December 16, 2002.

See: 34 N.J.R. 2615(a), 34 N.J.R. 4412(a).

Rewrote (b)1.

APPENDIX

CORRUGATED METAL PIPE STANDARDS

Corrugated metal pipe, when approved by the municipal engineer, shall meet the requirements and be installed in the following manner. Corrugated metal pipe for drainage structures is allowed in accordance with the map below. In areas with acid waters (shaded area on the map), design engineers may use aluminum alloy, provided the environmental limitations below are met. In neutral/alkaline waters (unshaded on the map), aluminum, aluminum-coated steel type 2, and polymeric-coated steel may be used, provided the environmental limitations below are met. Water pH and resistivity values must fall within the ranges shown below. Samples should be measured in accordance with ASTM G51 and G57. Avoid sampling water during storm events or for two days following a storm to insure more typical readings. If there are severe corrosive conditions (pH <4), fiber-bonded steel pipe should be used.

ENVIRONMENTAL LIMITS FOR CORRUGATED METAL PIPE

Pipe type	pH	Resistivity values (ohm-cm)
aluminum	4-9	> 500
aluminum-coated type 2	5-9	>1500
polymeric coated	5-9	>1500
fiber bonded	<4	—

If the design velocity is greater than 10 feet per second, a one-half bituminous coating and paved invert in accordance with ASTM A849 (AASHTO M190) is required.

Minimum depth of coverage shall be as follows:

MINIMUM DEPTH OF COVERAGE FOR CORRUGATED METAL PIPE

Pipe diameter (inches)	Minimum cover (inches) from top of pipe to bottom of flexible payment or top of rigid pavement
12 inches to 48 inches	12 inches
54 inches of more	Per manufacturer's recommendations

Corrugated aluminum pipe shall conform to the requirements of ASTM B745 (AASHTO M196) for types I, II, IR, IIR, and III.

Corrugated aluminum-coated steel type 2 pipe shall conform to the requirements of ASTM A760 (AASHTO M36) for types I, II, IR, IIR, ands III and have an aluminum-one ounce type 2 coating as specified in ASTM A929 (AASHTO M274).

Corrugated polymeric-coated steel pipe shall conform to the requirements of ASTM A762 (AASHTO M36) for types I and II and have a polymeric 10% coating as specified in ASTM A743 (AASHTO M246).

Corrugated fiber-bonded steel pipe shall conform to the requirements of ASTM A760 (AASHTO M36) for types I and II and have an aramid fiber composite coating as specified in ASTM A885. In addition, the pipe shall be bituminous coated as specified in ASTM A849 (AASHTO M190).

Corrugated metal pipe shall be fabricated with annual corrugations by riveted lap joint construction or with helical corrugations and a continuous weld or lock seam extending from end to end of each length of pipe.

Connecting bands shall be manufactured in accordance with ASTM A760 (steel) or B745 (aluminum) and have the same base metal and coating as the corrugated metal pipe. All pipe ends shall be annularly reformed a minimum of two corrugations.

Fittings and end sections shall be of the same base metal and coating as the corrugated metal pipe.

Corrugated metal pipe shall be installed per ASTM A798 (steel) or ASTM B788.

Maximum cover and structural design of corrugated metal pipe shall be per ASTM A796 (steel) or ASTM B790.

03/05/87

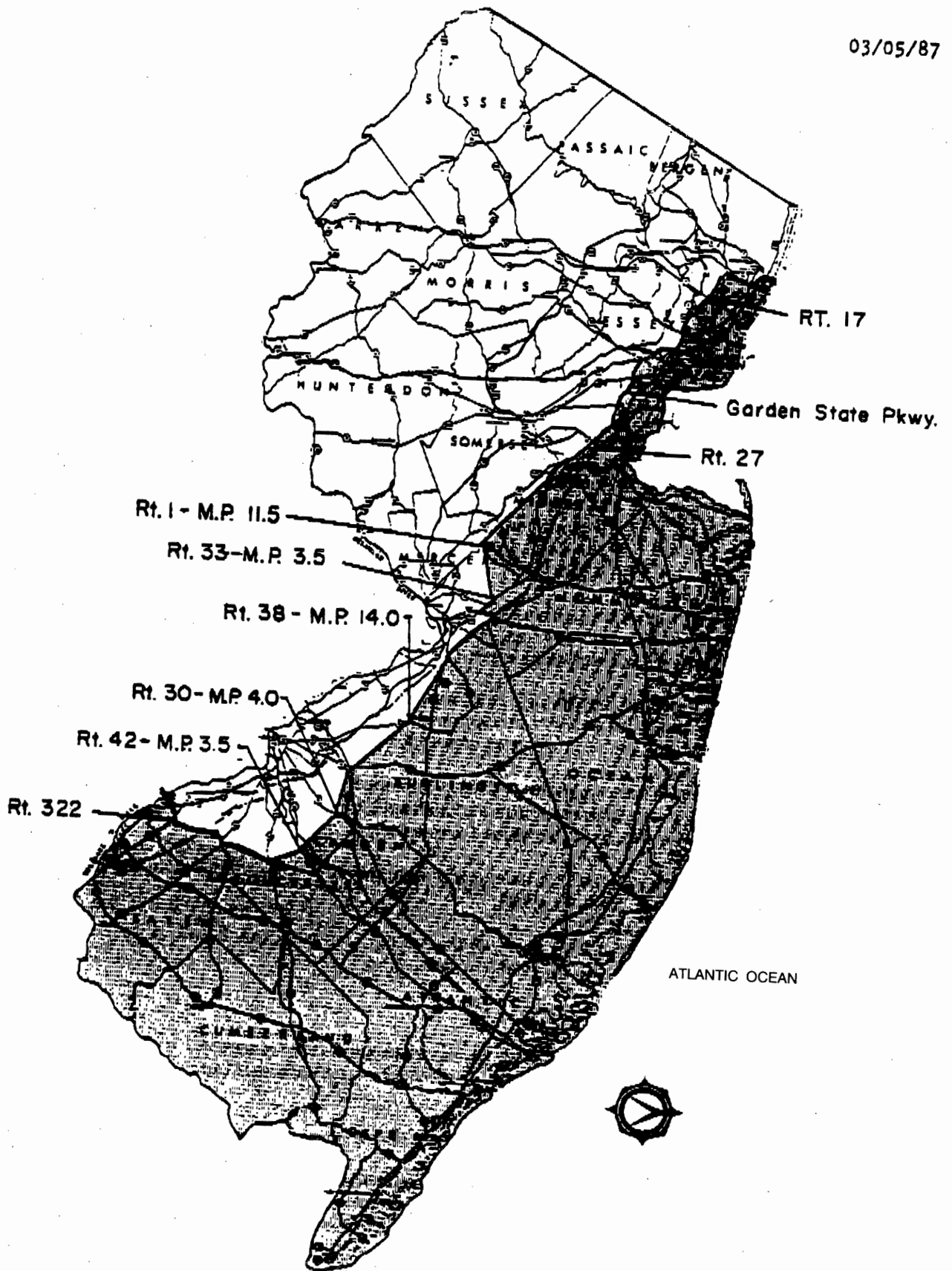

Administrative correction.
See: 29 N.J.R. 1296(a).

SUBCHAPTER 8. REFERENCED STANDARDS

5:21-8.1 Referenced standards

(a) The following is a list of the standards referenced in this chapter. The standards are listed by the promulgating agency of the standard, the standard identification, the edition of the standard, the title of the standard, and the section(s) of this code that reference the standard. The standards listed in this chapter are not adopted or to be used in their entirety unless the rules specifically so state. The use of the standards included in this chapter is limited to those specific areas of the standard for which this chapter directs the user to the standard.

- American Association of State Highway and Transportation Officials (AASHTO), 444 North Capital Street, N.W., Suite 249, Washington, DC 20001. Tel. (202) 624-5800 or (800) 231-3475.

<u>Standard reference number</u>	<u>Title</u>	<u>Referenced in N.J.A.C. section number</u>
M33-93	Standard Specification for Preformed Expansion Joint Filler for Concrete (Bituminous Type)	Figure 4.1 (Concrete Vertical Curb)
M43-88	Standard Specification for Sizes of Aggregate for Road and Bridge Construction	Figure 6.1
M114-91	Building Brick (Solid Masonry Units Made from Clay or Shale)	5:21-6.2(c)11vii(1)
M213-92	Standard Specification for Preformed Expansion Joint Fillers for Concrete Paving and Structural Construction (Nonextruding and Resilient Bituminous Types)	Figure 4.1 (Concrete Vertical Curb)
M252-94	Standard Specification for Corrugated Polyethylene Drainage Tubing	5:21-7.3(d)3
M294-94	Standard Specification for Corrugated Polyethylene Pipe, 12-to 36-in. Diameter	5:21-7.3(d)3
T99-94	Standard Method of Test for the Moisture-Density Relations of Soils Using a 5.5-lb. (2.5 kg) Rammer and a 12-in. (305 mm) Drop	5:21-7.3(d)3
2001 Edition	Standard Specification for a Policy on Geometric Design of Highways and Streets	5:21-4.19(b)6
1999 Edition	AASHTO Guide for the Development of Bicycle Facilities	5:21-4.20(a)5:21-4.20(b) Table 4.3
1993 Edition	Guide for Design of Pavement Structures	5:21-4.18(b) Figure 4.2 Figure 4.3 Figure 4.4 Figure 4.5

- American Concrete Pipe Association, Suite 105, 8618 Westwood Center Drive, Vienna, Virginia 22182. Tel. (703) 821-1990. Concrete Pipe Association of New Jersey, Post Office Box 1013, Dover, New Jersey 07802-1013. Tel. (201) 328-8723.

<u>Standard reference number</u>	<u>Title</u>	<u>Referenced in N.J.A.C. section number</u>
Minimum Cover (Minimum Depth of Coverage over Concrete Pipe)	Published in Concrete Pipe Association of New Jersey Newsletter, "The Pipeline," September/October 1985; table derived from information provided by the American Concrete Pipe Association	Table 7.4

- American Society for Testing and Materials (ASTM), 100 Barr Harbor, West Conshohocken, Pennsylvania 19428. Tel. (610) 832-9500.

<u>Standard reference number</u>	<u>Title</u>	<u>Referenced in N.J.A.C. section number</u>
A48-92	Standard Specification for Gray Iron Castings	5:21-6.2(c)11v 5:21-7.4(f)
A536-84	Standard Specification for Ductile Iron Castings	5:21-6.2(c)11v
C33-93	Standard Specification for Concrete Aggregates	Figure 6.1
C76-90	Standard Specification for Reinforced Concrete Culvert, Storm Drain, and Sewer Pipe	5:21-6.2(c)6i 5:21-7.3(d)1i
C150-92	Standard Specification for Portland Cement	5:21-6.2(c)11vii(2)
C443-85a (1990)	Standard Specification for Joints for Circular Concrete Sewer and Culvert Pipe, Using Rubber Gaskets	5:21-6.2(c)11iv 5:21-7.3(d)1iii
C478-90b	Standard Specification for Precast Reinforced Concrete Manhole Sections	5:21-6.2(c)11iv 5:21-7.4(d)
C507-90	Standard Specification for Reinforced Concrete Elliptical Culvert, Storm Drain, and Sewer Pipe	5:21-7.3(d)1ii
C700-91	Standard Specification for Vitrified Clay Pipe, Extra Strength, Standard Strength, and Perforated	5:21-6.2(c)6iv
C877-91	Standard Specification for External Sealing Bands for Noncircular Concrete Sewer, Storm Drain, and Culvert Pipe	5:21-7.3(d)1iv
C923-89	Standard Specification for Resilient Connectors between Reinforced Concrete Manhole Structures, Pipes, and Laterals	5:21-6.2(c)11vi 5:21-7.4(d)
D448-86	Standard Classification for Sizes of Aggregate for Road and Bridge Construction	Figure 6.1
D1784-90	Standard Specification for Rigid Poly(Vinyl Chloride) (PVC) Compounds and Chlorinated Poly(Vinyl Chloride) (CPVC) Compounds	5:21-6.2(c)6ii(1)
D1785-91	Standard Specification for Poly(Vinyl Chloride) (PVC) Plastic Pipe, Schedules 40, 80, and 120	5:21-6.2(c)8 Table 7.6
D2241-89	Standard Specification for Poly(Vinyl Chloride) (PVC) Pressure Rated Pipe (SDR Series)	5:21-6.2(c)8 Table 7.6
D2321-89	Standard Practice for Underground Installation of Thermoplastic Pipe for Sewers and Other Gravity Flow Applications	5:21-6.2(c)6ii(2) 5:21-6.2(c)6ii(4) 5:21-7.3(d)3
D2444-92	Standard Test Method for Determination of the Impact Resistance of Thermoplastic Pipe and Fittings by Means of a Tup (Falling Weight)	5:21-6.2(c)6ii(2)
D3034-89	Standard Specification for Type PSM Poly(Vinyl Chloride) (PVC) Sewer Pipe and Fittings	5:21-6.2(c)6ii
D3139-89	Standard Specification for Joints for Plastic Pressure Pipes Using Flexible Elastomeric Seals	5:21-5.3(j)3
D3212-92	Standard Specification for Joints for Drain and Sewer Plastic Pipes Using Flexible Elastomeric Seals	5:21-6.2(c)6ii(3)
D3350-93	Standard Specification for Polyethylene Plastics Pipe and Fittings Materials	5:21-7.3(d)3
F477-90	Standard Specification for Elastomeric Seals (Gaskets) for Joining Plastic Pipe	5:21-6.2(c)6ii(3)
F679-89	Standard Specification for Poly(Vinyl Chloride) (PVC) Large Diameter Plastic Gravity Sewer Pipe and Fittings	5:21-6.2(c)6ii
F789-89	Standard Specification for Type PS-46 and Type PS-115 Poly(Vinyl Chloride) (PVC) Plastic Gravity Flow Sewer Pipe and Fittings	5:21-6.2(c)6ii
F794-91	Standard Specification for Poly(Vinyl Chloride) (PVC) Profile Gravity Sewer Pipe and Fittings Based on Controlled Inside Diameter	5:21-6.2(c)6ii
F949-92	Standard Specification for Poly(Vinyl Chloride) (PVC) Corrugated Sewer Pipe with a Smooth Interior and Fittings	5:21-6.2(c)6ii

4. American Society of Civil Engineers (ASCE), 345 East 47th Street, New York, New York 10017. Tel. (212) 705-7496 or (800) 548-2723.

<u>Standard reference number</u>	<u>Title</u>	<u>Referenced in N.J.A.C. section number</u>
ASCE Manual on Engineering Practice No. 60 1982	Gravity Sanitary Sewer Design and Construction	5:21-6.2(a) 5:21-6.2(c)10 5:21-6.2(c)11
WEF Manual of Practice FD-20 ASCE Manuals and Reports of Engineering Practice No. 77 (1993) ©1992	Design and Construction of Urban Stormwater Management Systems	5:21-7.3(e)

5. American Water Works Association (AWWA), 6666 West Quincy Avenue, Denver, Colorado 80235. Tel. (303) 794-7711 or (800) 926-7337.

Standard reference number	Title	Referenced in N.J.A.C. section number
ANSI/AWWA C104/A21.4-90	American National Standard for Cement-Mortar Lining for Ductile-Iron Pipe and Fittings for Water	5:21-5.3(j)1 5:21-6.2(c)6iii 5:21-7.3(d)2
ANSI/AWWA C105/A21.5-93	American National Standard for Polyethylene Encasement for Ductile-Iron Pipe Systems	5:21-5.3(j)1
ANSI/AWWA C110/A21.10-93	American National Standard for Ductile-Iron and Gray-Iron Fittings, 3 in. through 48 in. (75 mm through 1200 mm) for Water and Other Liquids	5:21-5.3(j)1
ANSI/AWWA C111/A21.11-90	American National Standard for Rubber-Gasket Joints for Ductile-Iron Pressure Pipe and Fittings	5:21-5.3(j)1 5:21-6.2(c)6iii 5:21-7.3(d)2
ANSI/AWWA C115/A21.15-88	American National Standard for Flanged Ductile-Iron Pipe with Threaded Flanges	5:21-5.3(j)1 5:21-6.2(c)6iii 5:21-7.3(d)2
ANSI/AWWA C150/A21.50-91	American National Standard for the Thickness Design of Ductile-Iron Pipe	5:21-5.3(j)1 5:21-7.3(d)2
ANSI/AWWA C151/A21.51-96	American National Standard for Ductile-Iron Pipe, Centrifugally Cast, for Water and Other Liquids	5:21-5.3(j)1 5:21-6.2(c)6iii 5:21-7.3(d)2
ANSI/AWWA C301-92	AWWA Standard for Reinforced Concrete Pressure Pipe, Steel Cylinder Type for Water and Other Liquids	5:21-5.3(j)2
ANSI/AWWA C303-95	AWWA Standard for Prestressed Concrete Pressure Pipe, Steel-Cylinder Type, for Water and Other Liquids	5:21-5.3(j)2
ANSI/AWWA C303-95	AWWA Standard for Concrete Pressure Pipe, Bar Wrapped, Steel Cylinder Type	5:21-5.3(j)2
ANSI/AWWA C500-86	AWWA Standard for Gate Valves for Water and Sewerage Systems	5:21-5.3(e)
ANSI/AWWA C502-85	AWWA Standard for Concrete Pressure Pipe, Bar Wrapped, Steel Cylinder Type	5:21-5.3(j)2
ANSI/AWWA C504-94	AWWA Standard for Gate Valves for Water and Sewerage Systems	5:21-5.3(e)
ANSI/AWWA C509-94	AWWA Standard for Dry-Barrel Fire Hydrants	5:21-5.4(b)1
ANSI/AWWA C600-93	AWWA Standard for Rubber-Seated Butterfly Valves	5:21-5.3(e)
ANSI/AWWA C900-89	AWWA Standard for Resilient Seated Gate Valves for Water Supply Service	5:21-5.3(e)
ANSI/AWWA C901-88	AWWA Standard for Installation of Ductile-Iron Water Mains and Their Appurtenances	5:21-7.3(d)2
ANSI/AWWA C905-88	AWWA Standard for Polyvinyl Chloride (PVC) Pressure Pipe, 4 in. through 12 in., for Water Distribution	5:21-5.3(j)3
	AWWA Standard for Polyethylene (PE) Pressure Pipe and Tubing, ½ in. through 3 in., for Water Service	5:21-5.3(j)5
	AWWA Standard for Polyvinyl Chloride (PVC) Water Transmission Pipe Nominal Diameters 14 in.	5:21-5.3(j)3

- | | | |
|--|--|--|
| C909-98 | through 36 in.
Molecularly Oriented Polyvinyl Chloride (PVCO) Pressure Pipe, 4 in. through 12 in. (100 mm through 300 mm), for Water Distribution | 5:21-5.3(j)3
5:21-6.2(c)8 |
| ANSI/AWWA
M31
©1992
Second Edition | Manual of Water Supply Practices—Distribution System Requirements for Fire Protection | 5:21-5.2(e) |
| 6. Asphalt Institute, Research Park Drive, Post Office Box 14052, Lexington, Kentucky 40512-4052. Tel. (606) 288-4960. | | |
| <u>Standard reference number</u>
MS-1, 8th Edition
August 1970 | <u>Title</u>
Thickness Design—Full-Depth Asphalt Pavement Structures for Highways and Streets | Referenced in
N.J.A.C. section
<u>number</u>
Table 4.7 |
| 7. Institute of Transportation Engineers (ITE), Suite 410, 525 School Street, S.W., Washington, DC 20024-2729. Tel. (202) 554-8050. | | |
| <u>Standard reference number</u>
Pub. No. IR-016C 6th Edition
First Printing 1997 | <u>Title</u>
Residential Street Design and Traffic Control
Trip Generation | Referenced in
N.J.A.C. section
<u>number</u>
5:21-1.5(d)2
5:21-4.1(b)
Table 4.1 |
| 8. Insurance Services Office, Inc. (ISO), 7 World Trade Center, New York, New York 10048. Tel. (212) 898-6000. | | |
| <u>Standard reference number</u>
©1980
Edition 6-80 | <u>Title</u>
Fire Suppression Rating Schedule | Referenced in
N.J.A.C. section
<u>number</u>
5:21-5.2(e) |
| 9. National Fire Protection Association (NFPA), 1 Batterymarch Park, Quincy, Massachusetts 02269. Tel. (617) 770-3000. | | |
| <u>Standard reference number</u>
Standard 291-1995
Standard 1963-1993 | <u>Title</u>
Fire Flow Testing and Marking of Hydrants
Fire Hose Connections | Referenced in
N.J.A.C. section
<u>number</u>
5:21-5.4(b)2
5:21-5.4(b)1 |
| 10. New Jersey Department of Agriculture, State Soil Conservation Committee, John Fitch Plaza, PO Box 330, Trenton, New Jersey 08625. Tel. (609) 292-5540. | | |
| <u>Standard reference number</u>
April 1987 | <u>Title</u>
Standards for Soil Erosion and Sediment Control in New Jersey | Referenced in
N.J.A.C. section
<u>number</u>
5:21-7.5(c)
5:21-7.5(f)3.ii |
| 11. New Jersey Department of Environmental Protection (NJDEP), Bureau of Revenue, Maps and Publications Sales Office, 428 East State Street, Trenton, New Jersey 08625. Tel. (609) 777-1038. | | |

<u>Standard reference number</u>	<u>Title</u>	<u>Referenced in N.J.A.C. section number</u>
June 1989	Ocean County Demonstration Study—Stormwater Management Facilities Maintenance Manual	5:21-7.6(c)4
September 1993	Stormwater and Nonpoint Source Pollution Control Best Management Practices Manual	5:21-7.6(c)4
Revised September 1995	Technical Manual for Land Use Regulation Program, Bureaus of Inland and Coastal Regulations, Stream Encroachment Permits	Table 7.2 5:21-7.6(c)4
August 1995	Pinelands Comprehensive Management Plan (New Jersey Pinelands Commission)	5:21-5.3(a) 5:21-6.2(a)

12. New Jersey Department of Transportation (NJDOT) PO Box 600, 1035 Parkway Avenue, Trenton, New Jersey 08625-0600. Tel. (609) 530-2000.

<u>Standard reference number</u>	<u>Title</u>	<u>Referenced in N.J.A.C. section number</u>
1989	Standard Specifications for Road and Bridge Construction	5:21-4.17(b) Table 4.8 Figure 4.2 Figure 4.3 Figure 4.4 Figure 4.5 5:21-6.2(c)6ii(5)
May 1992	Design Manual—Roadway (DOT's Division of Roadway Design, Bureau of Roadway Design Standards)	5:21-7.4(a) 5:21-7.2(c)2 5:21-7.2(c)3 Figure 7.1 Figure 7.2
November 1995	Planning and Design Guidelines for Bicycle-Compatible Roadways and Bikeways	5:21-4.18(b)

13. New Jersey Society of Municipal Engineers (NJSME), 196 West State Street, Trenton, New Jersey 08608. Tel. (609) 393-0102.

<u>Standard reference number</u>	<u>Title</u>	<u>Referenced in N.J.A.C. section number</u>
Second Edition November 1991	Asphalt Handbook for County and Municipal Engineers	Table 4.7

14. Portland Cement Association, 5420 Old Orchard Road, Skokie, Illinois 60076-0726. Tel. (847) 966-6200

<u>Standard reference number</u>	<u>Title</u>	<u>Referenced in N.J.A.C. section number</u>
©1984	Thickness Design for Concrete Highway and Street Pavements	Table 4.7

15. United States Army Corps of Engineers, Water Resources Support Center, The Hydrologic Engineering Center, 609 Second Street, Davis, California 95616. Tel. (916) 756-1104.

<u>Standard reference number</u>	<u>Title</u>	<u>Referenced in N.J.A.C. section number</u>
†Technical Paper No. 82 May 1981	The New HEC-1 Flood Hydrograph Package	5:21-7.2(c)

16. United States Department of Agriculture (USDA), Soil Conservation Service, Post Office Box 2890, Washington, DC 20013. Tel. (202) 205-0026.

Standard reference number	Title	Referenced in N.J.A.C. section number
†Technical Release 20 PB83-223768 May 1982	Computer Program for Project Formulation— Hydrology	5:21-7.2(c) 5:21-7.5(d)
†Technical Release No. 55 PB87-101580 2nd Edition June 1986	Urban Hydrology for Small Watersheds	5:21-7.2(c)1 5:21-7.2(c)3 5:21-7.2(c)6 5:21-7.5(d)1 5:21-7.5(f)5ii
†Technical Release No. 56 PB85-239622 December 1974	Guide for Design and Layout of Vegetative Wave Protection for Earth Dam Embankments	
†Technical Release No. 69 PB85-245165 February 1983	Riprap for Slope Protection Against Wave Action	5:21-7.5(f)5ii
†PB85-175164/LT July 1984	Engineering Field Manual for Conservation Practices	5:21-7.5 (f)5vii
†PB 243 644/LT	National Engineering Handbook	5:21-7.5(f)5vii
†PB 243 645/LT	Section 5 Hydraulics	
†PB 279 759/LT	Section 11 Drop Spillways Section 14 Chute Spillways	

17. United States Department of Commerce (USDOC), Bureau of the Census, Washington, D.C. 20233. Tel. (202) 482-2000.

Standard reference number	Title	Referenced in N.J.A.C. section number
1975-1980 (Data tabulated by Rutgers University)	Public Use File—New Jersey	Table 4.4 Table 5.1

18. United States Department of Transportation (USDOT), Federal Highway Administration (FHWA), 820 First Street, S.E., Washington, DC 20002. Tel. (301) 322-4961.

Standard reference number	Title	Referenced in N.J.A.C. section number
AC150/5320-5B July 1970	Airport Drainage	5:21-7.2(c)1
†Hydraulic Engineering Circular No. 15 Report No. FHWA-EPD-86-111 PB86-184835 October 1975	Design of Stable Channels with Flexible Linings	5:21-7.5(f)3ii
†Report No. FHWA-TS-79-225 PB83-259903 August 1979	Design of Urban Highway Drainage, The State of the Art	Table 7.3
†Hydraulic Design Series No. 4 Report No. FHWA-EPD-86-103 May 1965 (Reprinted March 1983)	Design of Roadside Drainage Channels	5:21-7.2(c)1
†Hydraulic Design Series No. 5 Report No. FHWA-IP-85-15 PB86-196961 September 1985	Hydraulic Design of Highway Culverts	5:21-7.1(h)
‡1988 Edition	Manual on Uniform Traffic Control Devices for Streets and Highways	5:21-4.13(a)

† Documents obtainable from the National Technical Information Service, Springfield, Virginia 22161. Tel. (703) 487-4650.

‡ Documents obtainable from the United States Government Printing Office, Superintendent of Documents, Post Office Box 371954, Pittsburgh, Pennsylvania 15250-7954. Tel. (202) 512-1800.

19. Urban Land Institute, Suite 500 West, 1025 Thomas Jefferson Street, N.W., Washington, D.C. 20007-5201. Tel. (800) 321-5011.

Standard
reference number
ULI-ASCE-NAHB
1975

Title
Residential Storm Water
Management: Objectives, Principles,
and Design Considerations

Referenced in
N.J.A.C. section
number
Table 7.5

† Documents obtainable from the National Technical Information Service, Springfield, Virginia 22161. Tel. (703) 487-4650.

‡ Documents obtainable from the United States Government Printing Office, Superintendent of Documents, Post Office Box 371954, Pittsburgh, Pennsylvania 15250-7954. Tel. (202) 512-1800.

Administrative correction.
See: 29 N.J.R. 1296(a).
Administrative correction.
See: 29 N.J.R. 2816(a).
Amended by R.1999 d.374, effective November 1, 1999 (operative May 1, 2000).
See: 31 N.J.R. 477(a), 31 N.J.R. 3259(a).
Rewrote the section.
Administrative correction.

See: 32 N.J.R. 684(b).
Amended by R.2000 d.480, effective December 4, 2000 (operative June 3, 2001).
See: 32 N.J.R. 2670(b), 32 N.J.R. 4277(a).
Added designation (a) to the main paragraph; amended tables in 1, 3, 5, 7, 12 and 13.
Amended by R.2002 d.399, effective December 16, 2002.
See: 34 N.J.R. 2615(a), 34 N.J.R. 4412(a).
Rewrote the section.