

R67
1972e

.90
R628
1972e

[Handwritten signature]

NJDOT Report No. 72-007-7716

TWO-WIRE EMERGENCY CALL SYSTEM

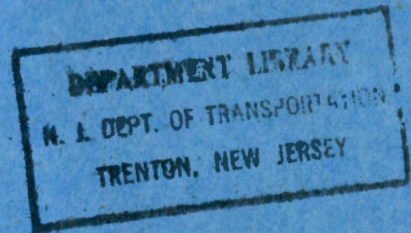

FINAL REPORT

by

E. F. Reilly, R. L. Hollinger and J. Santacroce

prepared by

Bureau of Operations Research
Division of Research and Development
New Jersey Department of Transportation

HPR Study Number - 7716

Prepared in cooperation with the U.S. Department
of Transportation, Federal Highway Administration

April 14, 1972

The opinions, findings, and conclusions expressed
in this publication are those of the authors and
not necessarily those of the Federal Highway
Administration.

2.04

New Jersey State Library

ACKNOWLEDGMENT

The authors wish to express their appreciation for the assistance given them in this project by the Bureau of Instrumentation Services and the Bureau of Equipment, New Jersey Department of Transportation, and by the New Jersey State Police.



1. Report No	2. Government Accession No	3. Recipient's Catalog No	
4. Title and Subtitle Two-Wire Emergency Call System - Final Report		5. Report Date April 14, 1972	6. Performing Organization Code
7. Author(s) E.F. Reilly, R.L. Hollinger, J. Santacroce		8. Performing Organization Report No 72-007-7716	
9. Performing Organization Name and Address New Jersey Department of Transportation Bureau of Operations Research Division of Research and Development 1035 Parkway Avenue, Trenton, New Jersey		10. Work Unit No	11. Contract or Grant No HPR Study Number - 7716
12. Sponsoring Agency Name and Address Same as #9		13. Type of Report and Period Covered Final Report	
14. Sponsoring Agency Code		15. Supplementary Notes None	
16. Abstract <p>The results of the installation and usage tests of the two-wire emergency call system do not indicate any significant advantages of the system over other types of call systems. Before installation and after installation field surveys were conducted to determine the number of motorists needing aid along the roadway and the type of problems they had. Details of servicing times for the stopped motorists also were collected. Records were maintained for system installation and maintenance costs. The summaries of the field survey and system costs are included in the report. Costs for two other types of system (telephone and call box) used in other states are included for comparison.</p>			
17. Key Words Emergency Call System		18. Distribution Statement	
19. Security Classif (of this report) Unclassified	20. Security Classif. (of this page) Unclassified	21. No. of Pages	22. Price

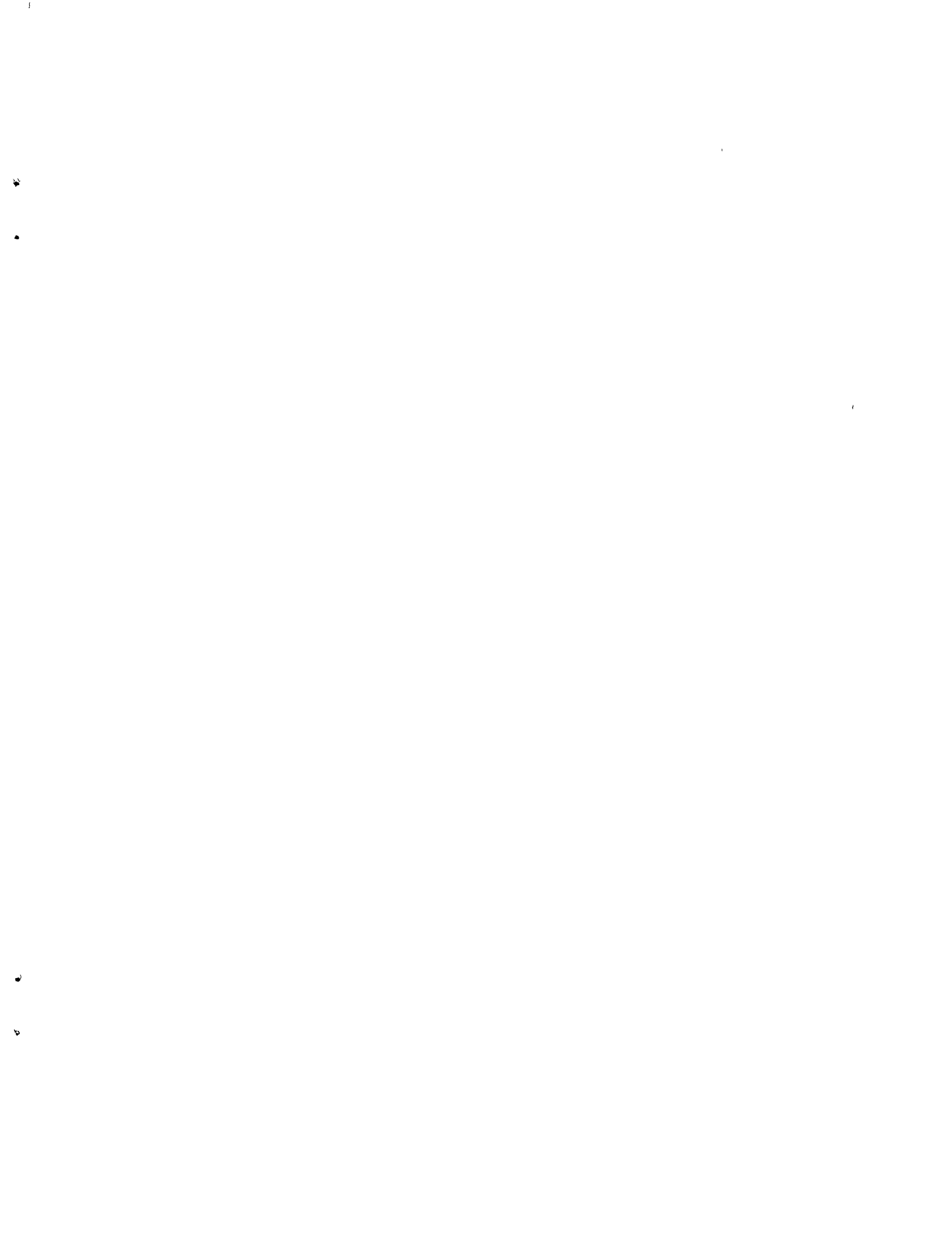

TABLE OF CONTENTS

	Page
List of Figures	ii
List of Tables.	iv
I. Summary and Conclusions	1
II. Introduction	3
III. System Description	4
IV. Study Procedures.	11
V. Results.	19
VI. Maintenance of System	24
VII. System Cost	26
VIII. Discussion.	28
Bibliography	35
Appendix	36



LIST OF FIGURES

<u>Figure</u>		<u>Page</u>
1	Map of I-287 Test Site	5
2	Delineator Post with Switch	7
3	Central Station Equipment Rack	7
4	Connection of One Leg of System	9
5	Central Station Monitoring Equipment Schematic (one of four required)	10
6	Emergency Call System Field Survey Form	14
7	New Jersey Department of Transportation Central Monitoring Station Log	17
8	New Jersey State Police Barracks Log	18
9	Motorist Information Signs	20
10	Number of Vehicles - Need Aid and Cumulative Percentage of Vehicles vs. Time (stop to first contact) 1970-1971 field survey	37
11	Number of Vehicles - Need Aid and Cumulative Percentage of Vehicles vs. Time (stop until aid arrives) 1970-1971 field survey	38
12	Number of Vehicles - Need Aid and Cumulative Percentage of Vehicles vs. Total Time Stopped 1970-1971 field survey	39
13	Number of Vehicles - Need Aid vs. Day of Week 1970-1971 field survey	40
14	Number of Vehicles - Need Aid vs. Hour of Day 1970-1971 field survey	41
15	Number of Vehicles Serviced by System vs. Time (stop to first contact, aid arrives, and total time stopped)	42
16	Number of Calls vs. Week - July & August 1971	43

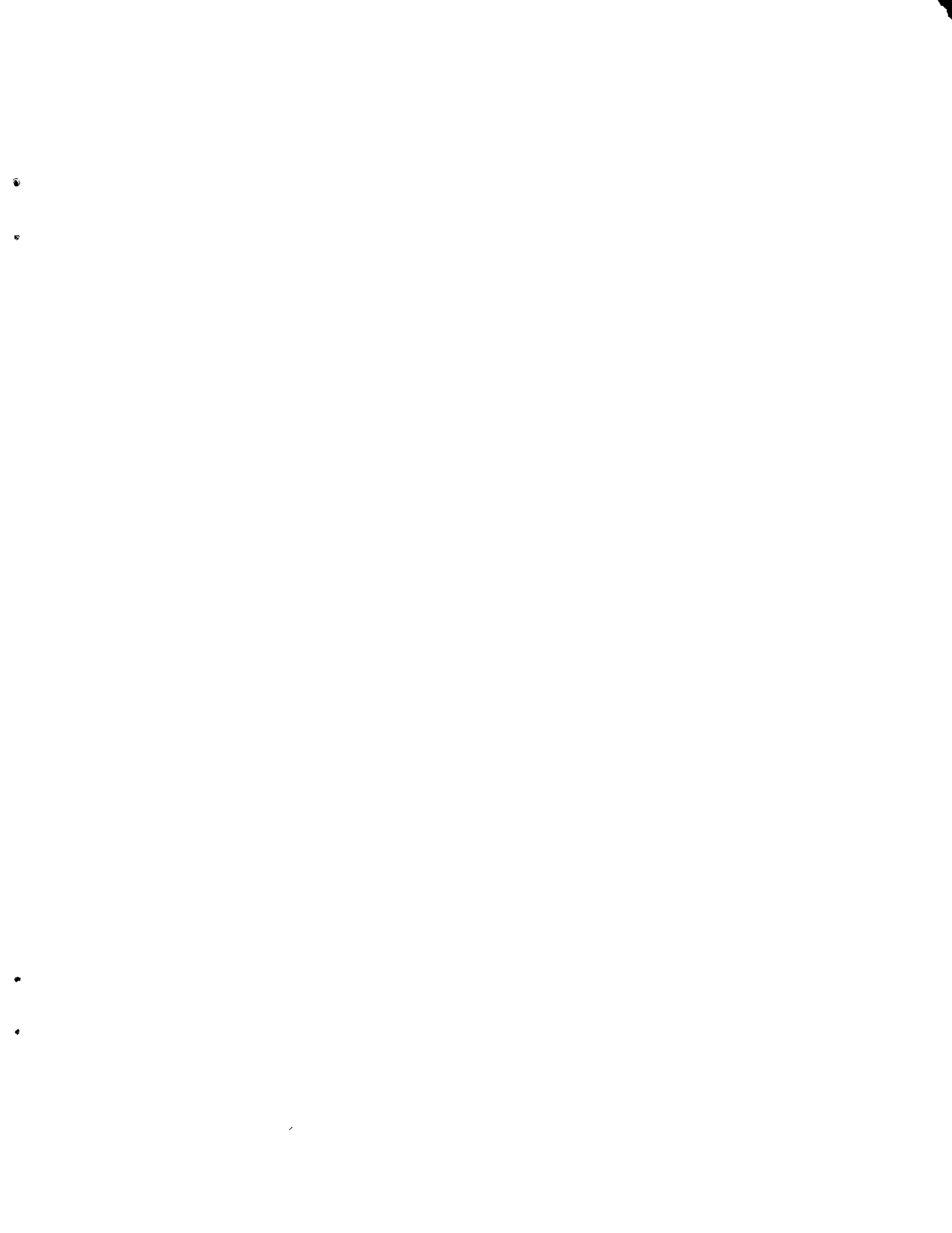

LIST OF FIGURES (con'd)

<u>Figure</u>		<u>Page</u>
17	Volume, Number and Rate of Vehicles Serviced by System vs. Day of Week - July & August 1971	43
18	Volume, Number and Rate of Vehicles Serviced by System vs. Hour of Day - July & August 1971	43

)

LIST OF TABLES

<u>Number</u>		<u>Page</u>
I	Details of Needs and Times for Vehicles Needing Aid During Field Survey Periods	22
II	Details of Needs for Vehicles Serviced by the System	24
III	Components of System Replaced	25
IV	Two-Wire Emergency Call System Costs	27
V	Alternate Call Systems Costs	29
VI	Reasons for "Gone on Arrivals"	32

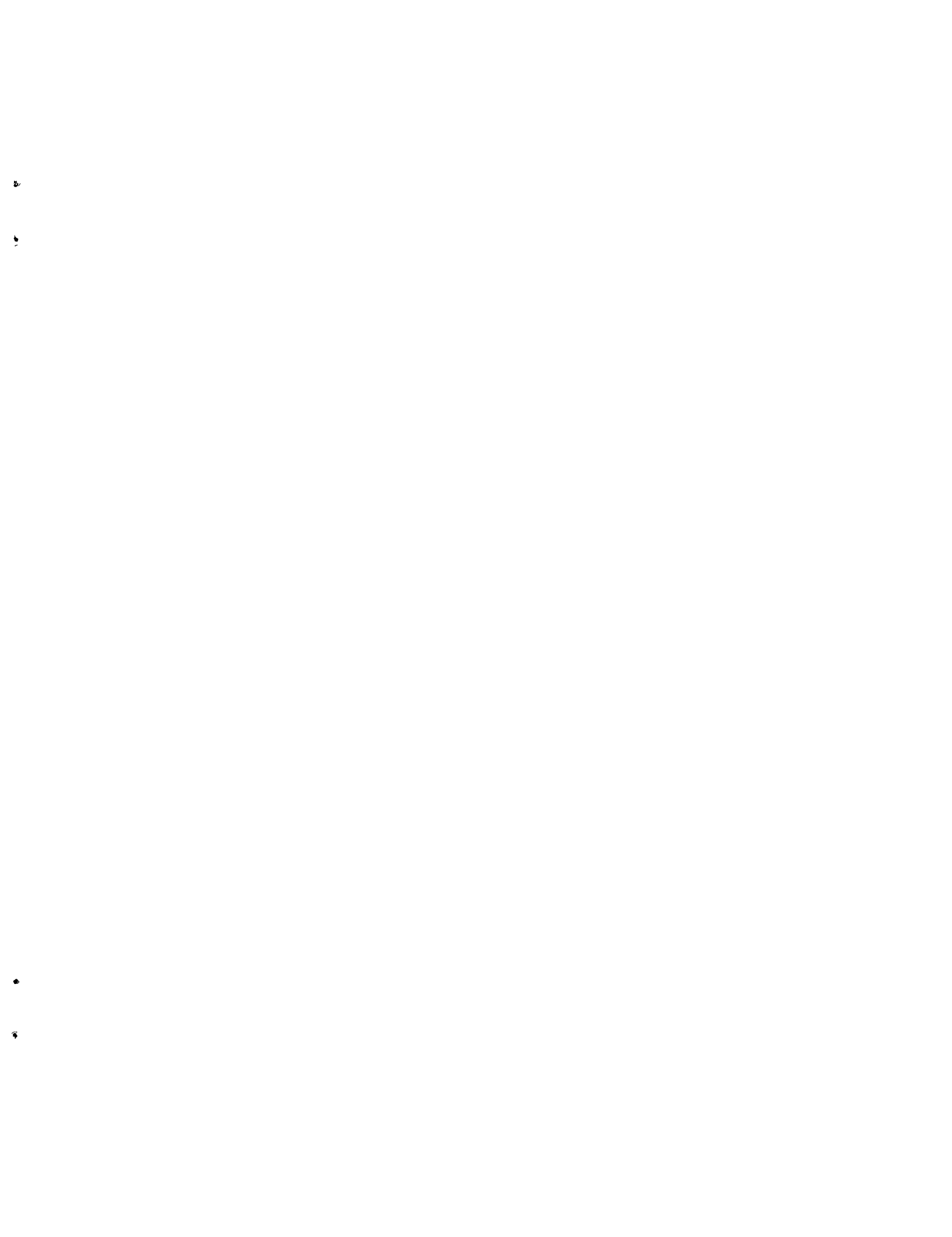

I. SUMMARY AND CONCLUSIONS

With the rapidly increasing mileage of limited access highways being built, the need for a means of summoning aid by stranded motorists is becoming of paramount importance. Emergency call systems are available using land wires or radio propagation. However, because of the unit station cost, call stations are usually located between 1/4 and 1 mile apart. In an attempt to place call stations closer together, the two-wire emergency call system was developed. This system provides call stations along the shoulder of the highway on each delineator post spaced an average of 200 feet apart. Because of the large number of call stations per mile, a low cost call station was devised. The station only provided a switch, which the motorist depresses to indicate a need. No provisions for type of aid needed, or verification of a call being received, were made. A vehicle is dispatched to the site of the call to collect the required information. Field surveys and system usage records were utilized to determine types of needs and servicing times.

The system was operated for 57 consecutive days during the summer of 1971. During this period there were 21.6 million vehicle miles of travel in the system operation area. A total of 539 calls were received at the monitoring station. One hundred and seventy were serviced by the system and 369 were classified as "Gone on Arrival."

A sample of the stopped motorists, made by a field study, indicated that 37 percent of the total calls received were "False Alarms," and 31 percent of the total calls serviced themselves or received aid from other motorists.

The 170 motorists, serviced by the system, yielded a rate of 7.9 vehicles serviced per million vehicle miles for the period of system operation. The rate of motorists needing aid, as determined from the field survey, was 26.8 per million vehicle miles, showing that almost one in three motorists needing aid were serviced through the call system.

The study did not show the two-wire system to have a low maintenance or installation cost in comparison with other types of call systems on a per mile basis. However, the two-wire system provided call boxes at 200 foot spacings instead of 1/4 to 1 mile spacings, thus reducing the stranded motorists' exposure to traffic while walking to a call station.

For the emergency call system studied to be effective, the time for aid to arrive must be reduced. The long periods of time taken for aid to arrive can be partially explained by the failure in some cases of the operating and servicing personnel to respond in a short period of time. It must be noted that this is true with any type of call system and should not be considered as a fault of the two-wire system alone. The total length of time stopped was much longer for the motorists who used the call system than for other motorists needing aid. This can be explained by the fact that motorists with serious (mechanical) problems were more likely to use the call system than those with more minor problems (tires, gas, etc.) thus increasing the time to effect repairs.

At the present stage of development, the two-wire emergency call system did not prove to have any significant advantages over other types of call systems now in use. If further research is

conducted, two areas should be included. First, the equipment should be refined and second, procedures must be implemented to reduce the time required for servicing agencies to respond to motorists who need aid. One approach is to investigate the advantages of contracting with service agencies for the service.

II. INTRODUCTION

Most Interstate highways have no means for motorists to summon aid in the event of a breakdown or emergency, and the Interstate highways are also noted for their isolation from service facilities, even in urban and suburban areas, due to access control.

The demand for improved communications between the motoring public and the highway system is steadily increasing. Several states have implemented emergency aid call systems, including voice (telephone), coded call boxes, and microwave systems.

Some of the existing systems include the following (NCHRP Synthesis of Highway Practices #7):

- (a) roadside commercial telephones at specific intervals,
- (b) roadside telephones connected to a central control station by cable or radio,
- (c) roadside call boxes with coded messages connected to a central control station by cable or radio,
- (d) two-way radio communication operated in a patrol network, and
- (e) detection of emergency situation by passing motorists.

The New Jersey Department of Transportation, in cooperation with the Federal Highway Administration, undertook the development of an emergency call system with the primary objectives of:

- (a) closely spaced emergency call stations,
- (b) low installation costs,
- (c) low maintenance costs, and
- (d) simplicity of system operation.

It was felt that an emergency call system utilizing a buried two-conductor cable with simple, momentary contact switches for signaling calls would best fulfill the objectives.

The system was designed to provide call stations at 200-foot intervals, thus providing access to the system much more frequently than with other systems. The system design concept is basically of a resistance measuring type. An emergency call is made by depressing (closing) a switch which shorts the buried cable, decreasing its resistance in an amount proportional to the distance from the resistance measuring unit, which resistance can be converted to a specific location along the highway.

Since the system utilized common principles (shorting a wire and measuring its resistance) for which simple equipment already existed, it was felt that the objectives of the system would be met.

After installation of a test system was completed, a period of operation, including a field survey, was conducted to determine if the system would fulfill the objectives as planned.

III. SYSTEM DESCRIPTION

The section of I-287 chosen for the test site was 8.2 miles long, extending from Main Street, Metuchen to River Road, Piscataway Township (see map - Figure 1). A cable comprised of two #14 gauge

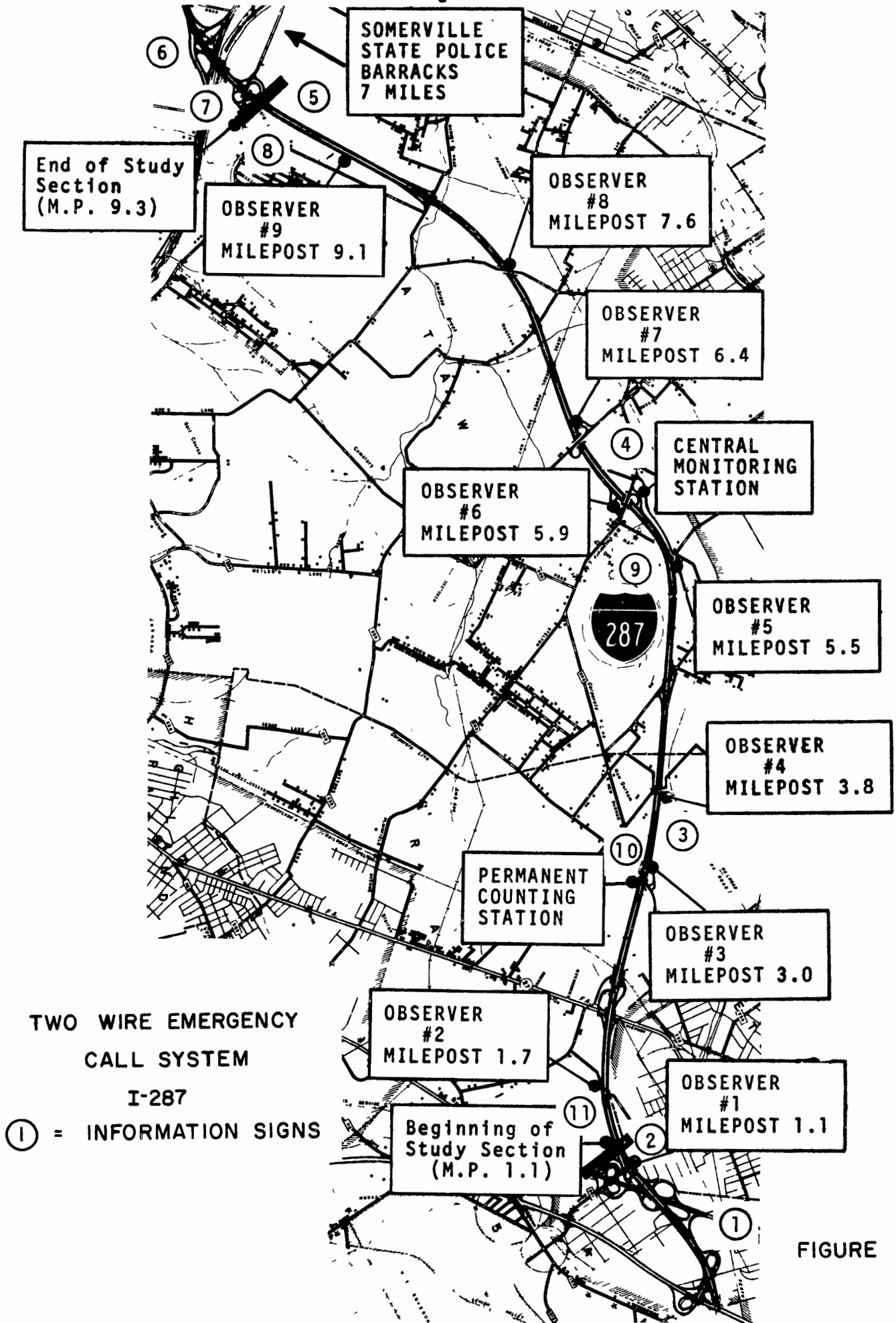

TWO WIRE EMERGENCY
CALL SYSTEM
I-287

① = INFORMATION SIGNS

FIGURE 1

copper wires insulated suitable for direct underground burial was trenched along the shoulder of the highway, approximately six inches below the surface. Wherever bridges and ramps were encountered, the cable was run through conduits. At each of the 425 delineator posts located on the north and south lanes of the 8.2-mile section, loops were brought up to a height of 3-4 feet.

The call stations, which were reflective push-button switches in a weatherproof protective enclosure, were connected to the cable and attached to each delineator post replacing the usual reflector (Figure 2). Instructional signs, as shown in Figure 2, were also attached to each delineator post to instruct motorists in the use of the system.

The 8.2-mile section of I-287, 16.4 miles in both directions, was divided into four separate segments consisting of approximately four miles per segment. With this arrangement, the cables from the four segments, two from the north lanes and two from the south lanes, were terminated at a central location. The central location contained the monitoring equipment, as well as the required electrical and telephone utilities. The monitoring equipment consisted of four identical test panels, one for each segment of cable, housed in an equipment rack, as shown in Figure 3. Each panel had a meter for indicating an emergency call location, a table for converting the meter reading to the actual milepost value, two push buttons, and two indicator lamps mounted in the front, and the associated electrical circuitry in the back. One indicator lamp would light when an emergency call had been made

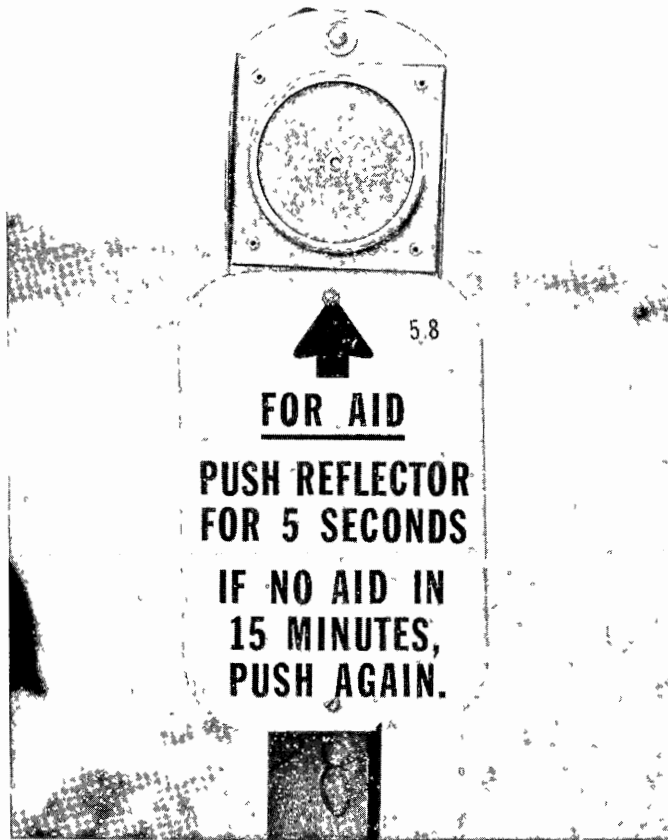

FIGURE 2

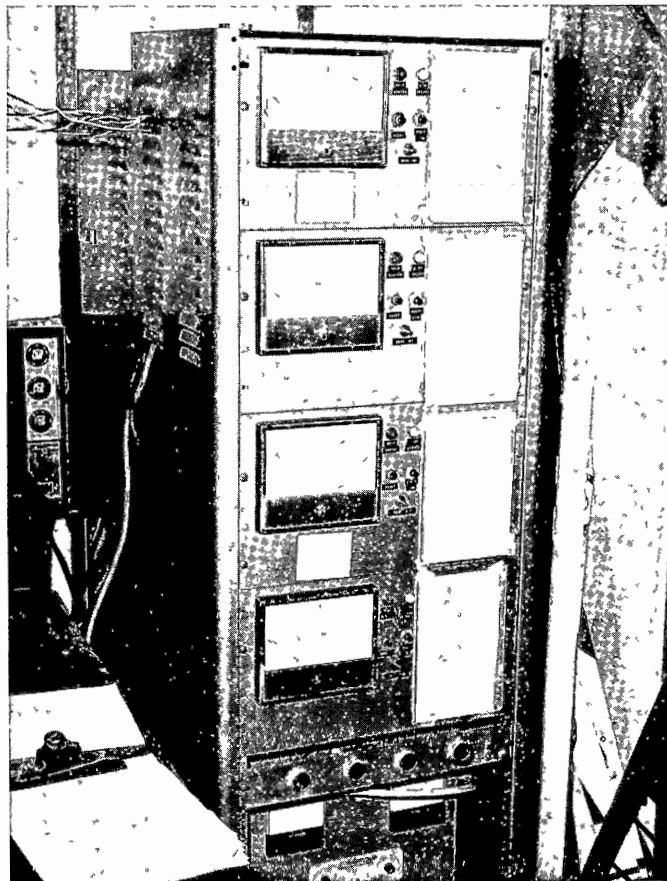

FIGURE 3

and was turned off by one of the push buttons after the necessary information was recorded. The other indicator lamp warned that a break in the two-wire cable had occurred making the system inoperative. By use of a known terminating resistance at the end of each segment, a continuous, low current flowed through the segment. Any break in the conductor would interrupt the current flow, causing the warning lamp to be actuated. The remaining push button was used for testing the electrical monitoring circuitry. Typical connections for one segment of the system are shown in Figure 4 with detailed monitoring circuitry shown in Figure 5.

The electrical source for the system consisted of two twelve-volt automobile storage batteries under constant charge from a 110-volt AC main. In the event of loss of AC power, the storage batteries were capable of supplying the necessary power to operate the system for up to 14 days.

Pressing one of the switches along the highway effected a change of potential in the current-carrying cable and caused a sensor to activate an audio and visual alarm. Simultaneously, a peak voltage memory voltmeter indicated the level of the change, corresponding to the location of the switch. After recording the reading, the attendant restored the line and checked the location chart for the exact location of the alarm.

Once the location of the emergency call was determined, it was necessary to dispatch a vehicle to the location to determine the type of assistance required (police action, fire, mechanical, etc.). The State Police were notified by telephone of each call and dispatched a patrol car, if one was available. If a State

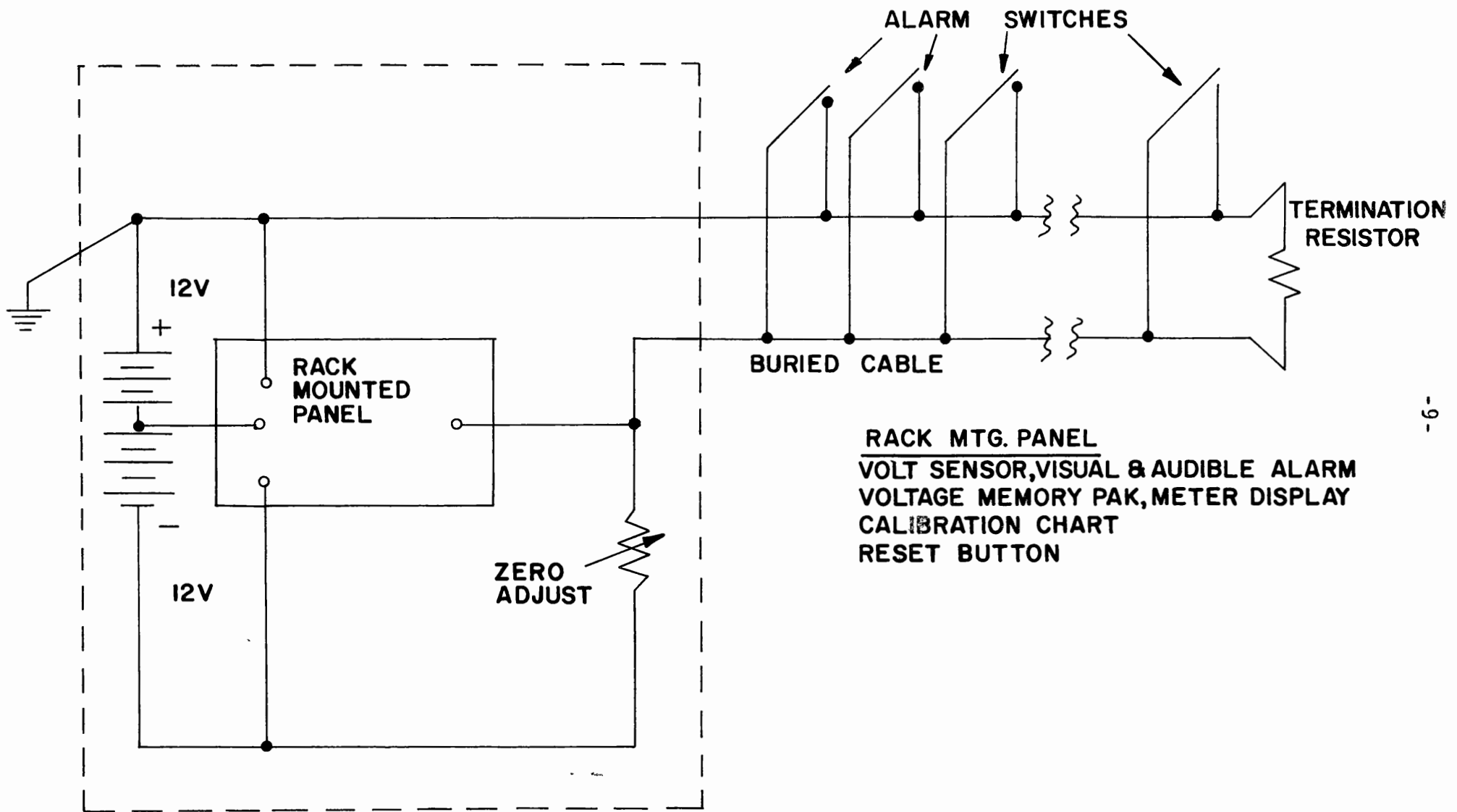

CONNECTIONS FOR ONE LEG OF THE SYSTEM.

FIGURE 4

DETAILED CONTROL PANEL SCHEMATIC

FIGURE 5

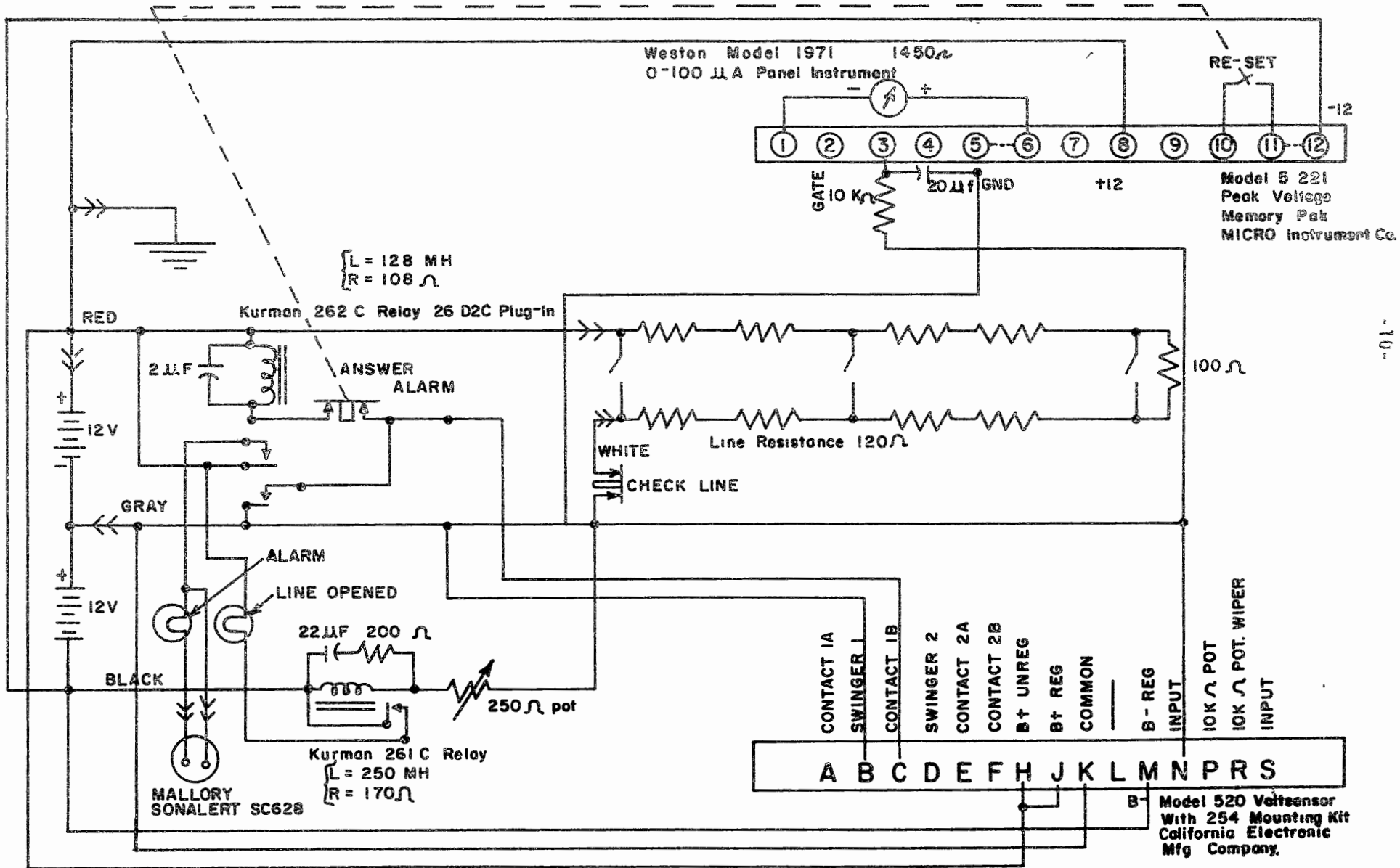

Police patrol car could not respond, a radio-equipped Department of Transportation vehicle was sent out. Upon determination of the type of assistance required, the information was radioed to the central monitoring station and relayed by telephone to the State Police who made arrangements for the aid.

IV. STUDY PROCEDURES

The bases for developing an effective Two-Wire Emergency Call System rests on the ability to:

- (a) keep installation costs low;
- (b) have a system where malfunctioning is a minor problem and damage caused by vehicles or vandals is minimized, easily detected, and quickly taken care of; and
- (c) service to the motorist in need of aid is given in a shorter time than he would have been serviced with no emergency call system.

Measurement of items "a" through "c" is possible, but unless another system is used for comparison, the cost and maintenance factors of "a" and "b" can only be subjectively evaluated. To avoid the possibility of misinterpreting the installation and maintenance cost of other emergency call systems, these items are simply itemized in a latter section of the report. The effectiveness of the system, using these costs, can then be "weighed" with other factors of policy, availability of funds, motorists' needs, etc.

Definite comparative measures are provided for item "c" between the summer period of 1970 (when no emergency call system was in operation) and the summer period of 1971 (when the two-wire

emergency call system was in operation). It is also possible to compare the service times between the drivers in 1971 who chose to use the two-wire call system and those drivers in 1971 who chose to service their own needs (either by themselves, through other drivers, or by walking off the road for service).

The field studies that provided this information, both in the summer of 1970 and the summer of 1971, consisted of stationing observers along the roadside during the daylight hours and patrolling the road in vehicles during the nighttime hours.

Information about drivers who used the call system during the 1971 survey was determined by matching results of the field survey with records of calls kept in the central monitoring station and the State Police barracks. From the 1970 and 1971 surveys' information about the time stopped, time from stop to first contact, time until aid arrives, type of assistance required, and other vehicles contacting the disabled motorist were obtained. Results of the surveys are presented later in the report.

Definition of Terms

"Need Aid" - Those motorists seen during the field survey by the observers who, in the observer's opinion, needed aid from another party in order to be on their way.

"First Contact" - Those motorists who stopped during the survey period needing aid and who were observed having contact with another motorist, State Police or Department of Transportation personnel.

"Serviced by System" - Motorists who pushed the emergency call switch during the period of operation, were contacted by State Police or Department of Transportation personnel, and their needs were satisfied by assistance obtained through the contact made by means of the system.

"Gone on Arrival" - Those calls which were responded to by the State Police or Department of Transportation personnel but resulted in no contact, or if contact was made, the motorist left before the service vehicle arrived.

Daytime Studies (Stationary Observers)

Figure 1 shows the positions of the observers over the study section of I-287. When all positions were covered, 5.7 of 8.2 miles of the system were observed, with the aid of binoculars. Using the form shown in Figure 6, the observers were stationed for the following lengths of time in each of the summers of 1970 and 1971:

14 days - 5:30 a.m. to 1:00 p.m., and

14 days - 12:30 p.m. to 8:30 p.m.

The entry on Figure 6 under "Time - Pushed Switch," was only used during the operation of the emergency call system during the summer of 1971.

Wooden posts were placed in the median every 0.1 mile as reference points for the observers. Because of the road geometry, the field of view of each of the observers varied.

Nighttime Studies (Patrolling Vehicles)

Using the form shown in Figure 6, an observer and driver in each of four vehicles patrolled the entire 8.2 miles of the

emergency call system for seven successive nights from 8:00 p.m. through 5:30 a.m. The use of four patrolling vehicles resulted in an average spacing between vehicles of 7.5 minutes. To maintain this headway, each vehicle, in the course of a round trip, passed a specified point on the road at a specific time. A fifth vehicle was used to allow 1/2-hour "breaks" every 2-1/2 hours of patrol to each of the four patrolling vehicles.

Volume Data

A permanent count station (with loop detectors) was located within the 8.2 miles of study roadway. Counting at the station was continuous and was tabulated (by hour and day) for three weeks in the primary direction and one week in the other direction. The subsequent counts were then used to form the basis for the "rate" of drivers that had emergency needs during the summer. Volumes over the study section varied considerably between the interchanges. By sample counts made throughout the study system, the basic count information from the permanent count station was adjusted to an "average" volume for the 8.2 miles of road within the two-wire call system limits.

Central Monitoring Station

The monitoring station was located near an interchange in the center of the 8.2 miles of the study section. The interchange afforded convenient access to the road for the Department of Transportation personnel when they were required to answer an alarm. This was only necessary when the State Police indicated they were unable to respond. It also permitted the call system to be easily divided into four segments, two to the north and

two to the south of the station. Two Department of Transportation personnel were monitoring the system at all times for the 57 days of operation of the emergency call system. Figure 7 is the form used at the monitoring station for recording the information about all alarms received through the system.

When this form was matched with the State Police log (described in the following section), the following information on system usage was obtained:

- (a) total calls received,
- (b) time and date of calls,
- (c) nature of motorist's need,
- (d) extent of misuse of system (gone on arrival), and
- (e) response time to alarm.

State Police Log

Each alarm received at the central monitoring station was immediately relayed by telephone to the Somerville State Police barracks (located 12 miles west of the monitoring station). The desk sergeant on duty at the time made the appropriate entries into a log (Figure 8) and advised the Department of Transportation personnel at the monitoring station as to whether a police patrol could respond to the alarm. If a State Trooper responded, he then supplied the desk sergeant with the vehicle description, type of service required, and time of arrival at the site. The desk sergeant then completed the log by entering the time and name of the service agency called to respond to the site.

If a State Trooper did not respond, but Department personnel did, the Department personnel then supplied the appropriate information to the sergeant at the Somerville barracks for entry into the log.

Motorist Information Signing

The motorists on I-287 were informed of the presence of the emergency call system by eleven 5' x 12' informational signs. The signs were placed prior to and throughout the system; the legends are shown in Figure 9, and their placement on the road is shown in Figure 1.

Smaller instructional signs (Figure 2) were placed below each delineator switch. No reference was made on these signs regarding the type of aid that would arrive. The operation of the system necessitated the determination of the type of aid required prior to sending aid. Hence, the initial contact with the motorist was made either through the State Police or Department of Transportation personnel.

V. RESULTS

1970 and 1971 Field Surveys

The following results reflect only those vehicles that were observed by field survey personnel and determined by them to need aid. The field surveys were conducted for 285 hours each summer during the 1970 and 1971 studies. The emergency call system was in operation for 1,368 consecutive hours during the summer of 1971.

MOTORIST INFORMATION SIGNS
TWO-WIRE EMERGENCY CALL

SIGN NO.

1 N.B. - M.P. 0.1

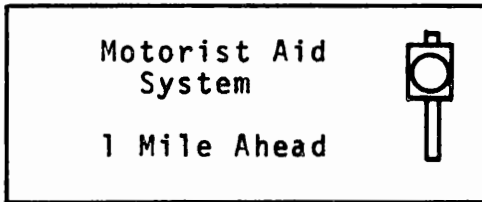

2 N.B. - M.P. 1.1

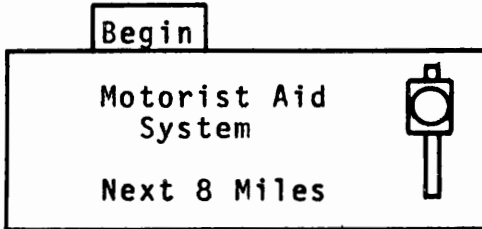

3 N.B. - M.P. 3.7

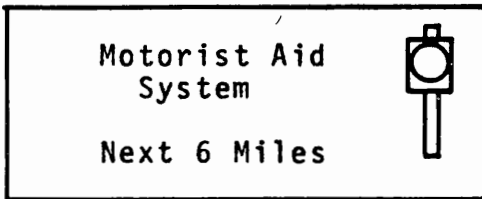

4 N.B. - M.P. 5.85

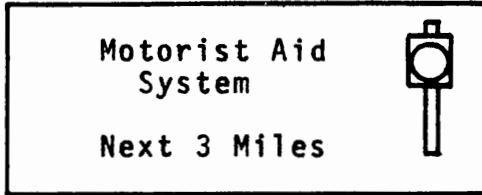

5 N.B. - M.P. 9.3

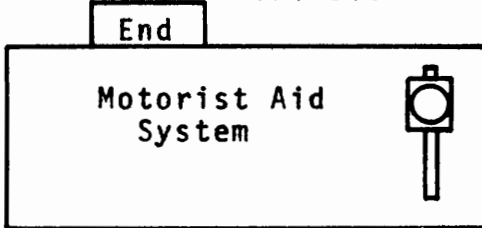

6 S.B. - M.P. 10.3

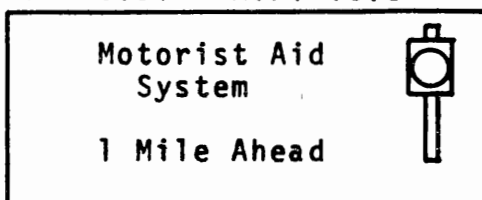

SIGN NO.

7 S.B. - M.P. 9.8

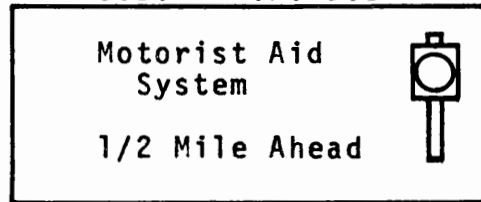

8 S.B. - M.P. 9.3

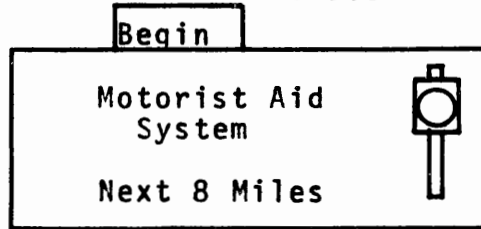

9 S.B. - M.P. 5.6

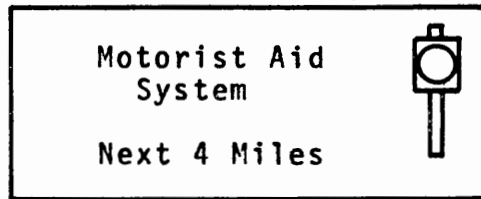

10 S.B. - M.P. 3.1

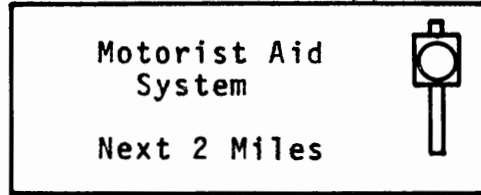

11 S.B. - M.P. 1.1

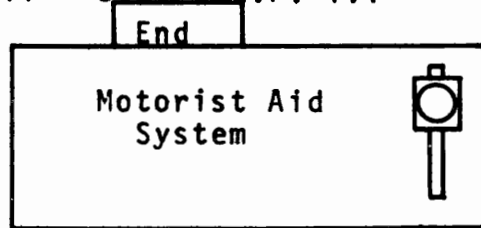

NOTE: White Scotchlite 10-inch C Series letters and blue painted background on 1/2-inch H.D. plywood, 5 ft. by 12 ft. panels.

FIGURE 9

The 1970 field survey results indicate that 62 motorists were observed to need aid for the 2.48 million vehicle miles traveled, yielding a rate of 25.0 motorists needing aid per million vehicle miles. During the 1970 survey period, approximately 3,250 motorists were seen to stop along the survey section for a rate of stopping of 1,310 per million vehicle miles.

The 1971 field survey results indicate that 101 motorists were observed to need aid for the 3.77 million vehicle miles traveled, yielding a rate of 26.8 motorists needing aid per million vehicle miles. During the 1971 survey period, approximately 5,500 vehicles were seen to stop along the survey section for a rate of stopping of 1,460 per million vehicle miles. The preceding rates of motorists needing aid include all motorists who stopped during the survey period, whether or not they left prior to the end of the survey period, because they were included in the vehicle miles of travel given.

A summary of the types of aid needed and the average times required for first contact to be made and for aid to arrive (as well as the average total stopped time) is given in Table I. The summary is for both the 1970 and 1971 field surveys. Graphic representations of the information summarized in Table I are presented in Figures 10 through 15 in the Appendix. Figures 10 through 12 present times for first contact, aid arrives, and total stopped time for all vehicles needing aid during the surveys. Figures 13 and 14 present the number of stops by day of week and hour of day for all vehicles needing aid during the surveys. Figure 15 presents

TABLE I

DETAILS OF NEEDS AND TIMES FOR ALL VEHICLES
NEEDING AID DURING FIELD SURVEY PERIODS

	1970 Field Survey (System Not in Operation)		1971 Field Survey (System in Operation)					
	All Vehs. No.	%	All Vehs. No.	%	Vehs. Not Ser. by System ¹ No.	%	Vehs. Ser. by System ¹ No.	%
<u>Need for Stop</u>								
Mechanical	28	45	50	50	35	47	15	58
Tire	13	21	25	24	20	27	5	19
Gas	9	14	5	5	4	5	1	4
Other ²	12	20	21	21	16	21	5	19
Average Time (Minutes) ³								
To First Contact	42		30		28		38	
Until Aid Arrives	44		48		44		60	
Total Time Stopped	65		74		69		90	

1. These tabulations do not include those vehicles which had stopped before the beginning of the day's field survey.
2. The "other" category includes those motorists whose needs could not be determined by the field observers, or by the failure of the operating personnel to properly fill out the data log, and one motorist who required water for his vehicle.
3. Includes times for only those vehicles whose total stopped time occurred within the time limits of the survey periods.

times for first contact, aid arrives, and total stopped time for vehicles which needed aid and were serviced by the system during the 1971 survey.

Emergency Call System Usage

During the 57 days of operation, 539 calls were received at the central monitoring station, of which 170, or 32 percent, were classified as "Serviced by System." The remaining 369 calls, or 68 percent, were classified as "Gone on Arrival." The 369 "Gone on Arrivals" can be divided into two groups. The first group includes those calls where the motorist had left before the State Police or Department personnel arrived, including the true "false alarm" calls and the ones where service was obtained from another source (passing motorist, etc.) before State personnel arrived. This group includes 311, or 84 percent, of the 369 "Gone on Arrival" calls. The second group includes those motorists with whom contact was made by State Police or Department personnel, but who left prior to the arrival of the service vehicle. Because of the initial contact being made with the State personnel, it is doubtful that many of these calls were true "false alarms," but, instead, assistance was received from another source before the service vehicle arrived. These calls comprise 58, or 16 percent, of the "Gone on Arrival" calls. Of the 539 calls received, the State Police responded to 224, or 42 percent, of the calls, and Department of Transportation personnel responded to 315, or 58 percent, of the calls.

The rate of vehicles serviced by the system for the 57 days of system operation (170 vehicles serviced by the system with

21.6 million vehicle miles of travel) was 7.9 per million vehicle miles. During the field survey, 26 vehicles were serviced by the system for 3.77 million vehicle miles of travel, which yields a rate of 7.0 vehicles serviced by the system per million vehicle miles.

A summary of the types of aid needed by the motorists who were serviced by the system is given in Table II.

TABLE II

DETAILS OF NEEDS FOR VEHICLES SERVICED BY THE SYSTEM

	<u>No. of Vehicles</u>	<u>Percent of Vehicles</u>
Mechanical	100	59
Tires	30	18
Gas	25	15
Other	15	8

Graphic representations of information concerning usage of the emergency call system are presented in Figures 16 through 18 in the appendix. Included in these figures is information from the 1971 field survey showing the number of calls and rate of service by day and by hour of day, along with total stopped time, time to first contact, and time until aid arrives.

VI. MAINTENANCE OF SYSTEM

A log of all maintenance service required by the system was kept for a period of seven months. The last two months were during the operation of the system. A total of 45 maintenance calls were handled. Two major problems were encountered: (1) failure of system due to electrical shorts to ground, and (2) destruction of posts

and switches by vehicles and lawn mowers. The types of maintenance problems encountered are reflected in Table III below:

TABLE III
COMPONENTS OF SYSTEM REPLACED

	<u>Quantity</u>
Posts Replaced	31
Posts Straightened	10
Switches Damaged	21
Switches Stolen	4
Instructional Signs Stolen	2
Buried Cable Replaced	40 feet

During the two months of operation, the system or part of the system was down for a total of 35 hours, due to a variety of electrical and test equipment malfunctions.

The most serious problem was due to shorts to ground, traced to excessive moisture in the underground splices and cable, or moisture and corrosion in the splices above ground. This problem was the most difficult to trace and repair. Repair time averaged five hours for the major down periods.

The remaining down periods were due to component failure in the test station monitoring equipment. These down times were relatively short compared to the periods described above. After one month of operation, all audio and visual alarm sensor cards developed a malfunction and were removed from the test set and not replaced. However, this did not in any way inhibit the operation of

the system. One memory voltmeter card, three relays, two capacitors, and indicator lamps were also replaced during this period.

Although the moisture problems were corrected during the down times, this problem recurred every time there was a rain storm or excessive humidity; the short would be relieved as the ground, cable or switches dried.

All maintenance calls were the responsibility of the Bureau of Instrumentation Services of the Department of Transportation.

VII. SYSTEM COST

Table IV is a presentation of the costs incurred in the installation and operation of the Two-Wire Emergency Call System. The system comprised 8.2 miles of highway along Interstate Route 287.

The cost of installing this system reflects the expense of the materials and equipment used, along with the salaries of the personnel who installed and inspected the system. The cost also includes all operational and maintenance costs incurred for 57 days, or 1.9 months of operation.

The operational costs include utilities, vehicle usage and salaries for two men per shift for three eight-hour shifts per day maintaining the central monitoring station. All personnel used in the monitoring station were employed by the New Jersey Department of Transportation with their salaries computed at an average rate of \$1,000 per man month. However, it is important to note that the system may be intended to be operated by the State Police. Thus, the operating costs of the system, if run as intended, may be quite

TABLE IV

TWO-WIRE EMERGENCY CALL SYSTEM COSTS
(200 FEET AVERAGE SPACING)
INSTALLATION EXPENSE (8.2 MILES)

MATERIALS AND EQUIPMENT:

Electrical Installation Contract	\$52,479.00
Electrical Equipment	3,500.00
Vehicle Expense	1,073.00
Approximate Cost of Wire	9,000.00
Cost of 425 Switches at \$15.54 a Switch	6,605.00
Housing for Equipment	1,000.00
Informational Signs	1,500.00
	<u>\$75,157.00</u>

SALARIES: (1)

Equipment Installation (1 man month)	\$ 1,000.00
Delineator Sign and Switch Installation (5 man months)	5,000.00
Inspection and Testing of the System (2-1/2 man months)	<u>2,500.00</u>
	\$ 8,500.00

TOTAL INSTALLATION EXPENSE \$83,657.00

Cost Per Mile (8.2 miles)	\$10,202.00
Cost Per Call Station (425 stations)	197.00

MAINTENANCE EXPENSE (57 DAYS)

Delineator Post and Switch Replacement	\$ 800.00
Electrical Equipment and Cable Maintenance	<u>200.00</u>
TOTAL MAINTENANCE EXPENSE (2-month period)	\$ 1,000.00

Cost Per Mile Per Month (8.2 miles) \$ 60.00

OPERATION EXPENSE (57 DAYS)

16 Man Months at \$1,000 Per Month	\$16,000.00
1 Vehicle at \$100 Per Month (2-month period)	200.00
Utilities	<u>250.00</u>
TOTAL OPERATION EXPENSE	\$16,450.00

Cost Per Month (1.9 months) \$ 8,660.00

(1) NOTE: Salaries are based on \$1,000 per man month.

negligible because of the use of normal police patrols to respond to the calls and the desk sergeant to monitor the operation in addition to his other duties.

The maintenance of the system was also conducted by Department of Transportation personnel. Maintenance costs involved materials and equipment needed to repair breakdowns in the system, and personnel salaries for time involved in making the repairs. If the system, as intended, was run by the State Police, it may have been necessary to contract personnel for handling the maintenance of the system.

Table V is a presentation of the expenditures of two other emergency call systems. Both of these systems provide the motorists with a means of summoning aid, as the Two-Wire Emergency Call System does, but differ in the mechanics of actual use. The two systems are the Michigan Telephone System and the Texas Call-Box System.

The costs of the two systems are broken down by installation, maintenance and operation. These costs may be used as a comparison between the systems.

VIII. DISCUSSION

The results of the study indicate that not all of the primary objectives were obtained. The system, as designed, did afford the motorist with call switches spaced very close to each other and was simple to operate. However, the two-month operating period did not indicate a low maintenance cost. Installation costs on a per-mile

TABLE V

ALTERNATE CALL SYSTEM COSTS

<u>MICHIGAN TELEPHONE SYSTEM</u> ⁽¹⁾		<u>TEXAS CALL-BOX SYSTEM</u> (2)	
<u>(1 MILE AVERAGE SPACING)</u>		<u>(1/4 MILE AVERAGE SPACING)</u>	
TOTAL INSTALLATION EXPENSE (30 miles)	\$290,170.00	TOTAL INSTALLATION EXPENSE (11 miles)	\$161,025.00 ⁽³⁾
COST PER MILE (30 miles)	\$9,670.00	COST PER MILE (11 miles)	\$14,639.00
COST PER CALL STATION (2/mile)	4,835.00	COST PER CALL BOX (8/mile)	1,830.00
TOTAL MAINTENANCE EXPENSE (3-1/2 years)	\$ 55,895.00	TOTAL MAINTENANCE EXPENSE (Annual)	\$ 20,000.00 ⁽⁴⁾
COST PER MILE PER MONTH (30 miles, 42 months)	\$ 56.00	COST PER MILE PER MONTH (11 miles, 12 months)	\$ 151.00
TOTAL OPERATION EXPENSE (Annual)	\$ 5,114.00	TOTAL OPERATION EXPENSE	NOT GIVEN
COST PER MONTH (12 months)	\$ 426.00		

- (1) Roth, Walter J., Final Report, Study, Michigan State Highway Commission, August 1971, pp. 10, 11.
- (2) Goolsby, Merrell E., and McCasland, William R., Evaluation of an Emergency Call-Box System, Texas Transportation Institute, December 1969, p. 41.
- (3) Includes Call-Box Maintenance Facility Cost.
- (4) Estimated Amount.

basis were high, but because there were 50 switches per mile, the cost per unit switch was low. The largest portion of the installation cost was the contract to bury the wire. The cost of burying the wire may have been much less if it had been performed by State forces instead of an outside contractor. This reduction in cost may have made the two-wire system installation cost less than that of either of other systems listed in Table V.

1970-1971 Field Study Comparison

In comparing the 1970 and 1971 field results, consideration must be given to the types of aid required. The comparisons in Table I show that a slight increase in the percentage of the mechanical and tire needs was evidenced during 1971. However, the 1971 results indicate a much higher percentage of mechanical difficulties for those motorists using the system, compared to those motorists that chose not to use the system.

It may be assumed that many motorists who felt they had a serious problem (mechanical) were inclined toward using the emergency call system. The needs of the 1970 motorists and the 1971 motorists that were not serviced by the system were very similar.

Also, in comparing the average total time stopped, average time to first contact and average time until aid arrived between 1970 and 1971, some interesting observations can be made. The average total time stopped and the average time until aid arrived for those that were serviced by the system were significantly higher than the corresponding times in 1970 and in 1971 of those that did

not utilize the emergency call systems. Although no conclusive evidence is available, we may assume that many of those motorists who felt they had a serious problem utilized the system. Also, when a motorist used the system, he frequently refused aid from passing motorists, indicating that he had aid coming; but there were times when the aid was delayed. For those motorists that did not use the system (in 1970 and 1971), the first contact was frequently the source of aid, probably because the type of aid required was of a minor nature.

Emergency Call System Usage

The fact that the system experienced a false alarm ("Gone on Arrival") rate of 68 percent is difficult to explain. Although we have no absolute evidence except during the survey, not all the "GOA's" should be classified as no aid needed. It is shown a percentage of GOA's did need aid, but were able to service themselves or received aid from passing motorists prior to initial contact by the State Police or Department personnel, or in some cases (16 percent), after initial contact, but before the service vehicle arrived. See Table VI for a breakdown of reasons for GOA's during the 1971 field survey period.

The operation of the emergency call system for 57 days showed that the majority of calls received and serviced were from those motorists having some form of mechanical problem (59 percent, Table II).

The next largest group had a tire problem (18 percent, Table II). The large variance between these two groups may be explained

in that only those motorists that had potentially serious problems tended to use the system to summon aid.

TABLE VI

REASONS FOR GONE ON ARRIVALS-FIELD SURVEY PERIOD - 1971

Reason for GOA	GOA (Before 1st Contact)		GOA (Before Service)		Total	
	<u>No.</u>	<u>%</u>	<u>No.</u>	<u>%</u>	<u>No.</u>	<u>%</u>
False Alarm	24	73	0	0	24	55
Fixed Self	1	3	2	20	3	7
Called Own Service	0	0	3	30	3	7
Other Motorist	3	9	5	50	8	19
Unknown	5	15	0	0	5	12
Total	33	100	10	100	43	100

A comparison of the field survey data for those who used the system (Table I) and the log of the central monitoring station for system usage (Table II) indicates a difference in percentages of two of the reasons for motorists summoning aid; those are, gas and other. The reasons for these differences can be attributed to the small time sample for the 1971 field survey, a lack of accurate identification on the part of the field survey personnel, and the failure to properly complete both the central monitoring station and the State Police logs.

Without an emergency call system, it may be expected that some motorists will have to wait excessively long periods of time before a first contact is made (another motorist stopping). In fact, this waiting period will add substantially to their total time stopped on the road. However, the operation of an emergency call system should show a reduction in the distribution of "time until first contact" (at least with the two-wire system, as described herein). The explanation of why this was not true (see Table I) follows.

The distribution of times for motorists awaiting aid (utilizing the call system) are shown in Figure 15. If it is assumed that one-half hour is a reasonable time for the operating personnel to respond to a call, and if the failure of the operating personnel to respond to all calls within that time could be overcome, the average time to first contact could be reduced by 18 minutes (Table I and Figure 15). Similarly, if the aid that is requested to respond to motorist can arrive within one hour after being notified of the need (a maximum of 1-1/2 hours after the time the motorist stopped), the average time stopped until aid arrives could be reduced by 15 minutes (Table I and Figure 15). It follows that a reduction of 15 minutes in the average time from stop until aid arrives would result in a similar reduction in the average total stopped time (Table I and Figure 15). The increased number of serious problems (mechanical) in 1971 over 1970 (50 vs. 28, see Table I) at least partially explains the longer average stopped time for 1971.

The rate of motorists serviced by the system was 7.0 per million vehicle miles during the survey periods and 7.9 per million vehicle miles for the 57 days of system operation. The rate of need aids, 26.8 per million vehicle miles, determined from the survey periods, is assumed to be constant for the 57 days of system operation. From these figures, it is determined that between one of three and one of four motorists needing aid utilized the emergency call system during the period of system operation.

BIBLIOGRAPHY

- Roth, W. J., "Study of Rural Freeway Emergency Communications for Stranded Motorists." TSD-TR-132-71, Michigan Department of State Highways, 83 pp. (August 1971).
- Tweedie, R. W., and Taylor, J. E., "An Evaluation of the Northway Emergency Telephone System." Highway Research Record 202 (1967) pp. 67-75.
- Goolsby, M. E., and McCasland, W. R., "Evaluation of An Emergency Call Box System." Research Department 132-1F, Texas Transportation Institute, 57 pp. (December 1969).
- Kuprijanow, A., Rosenzweig, S., and Warskow, M. A., "Motorists Needs and Services on Interstate Highways." NCHRP Report 64, 68 pp. (1969).
- "Motorist Aid Systems," National Cooperative Highway Research Program. Synthesis of Highway Practice #7, 28 pp. (1971).
- Pogust, F., Kuprijanow, A., and Forster, H., "Means of Locating and Communicating with Disabled Vehicles - Interim Report." NCHRP Report 6, 56 pp. (1964).
- Pogust, F., and Meiselback, C., "Means of Locating Disabled or Stopped Vehicles." NCHRP Report 40, 40 pp. (1967).
- Meiselback, C. J., Wispart, I. S., Inhelder, H. R., and Emery, R. H., "FLASH: A Disabled Vehicle Detection System." IEEE Trans. on Vehicular Technol. Vol. VT-19, pp. 82-89 (Feb. 1970).

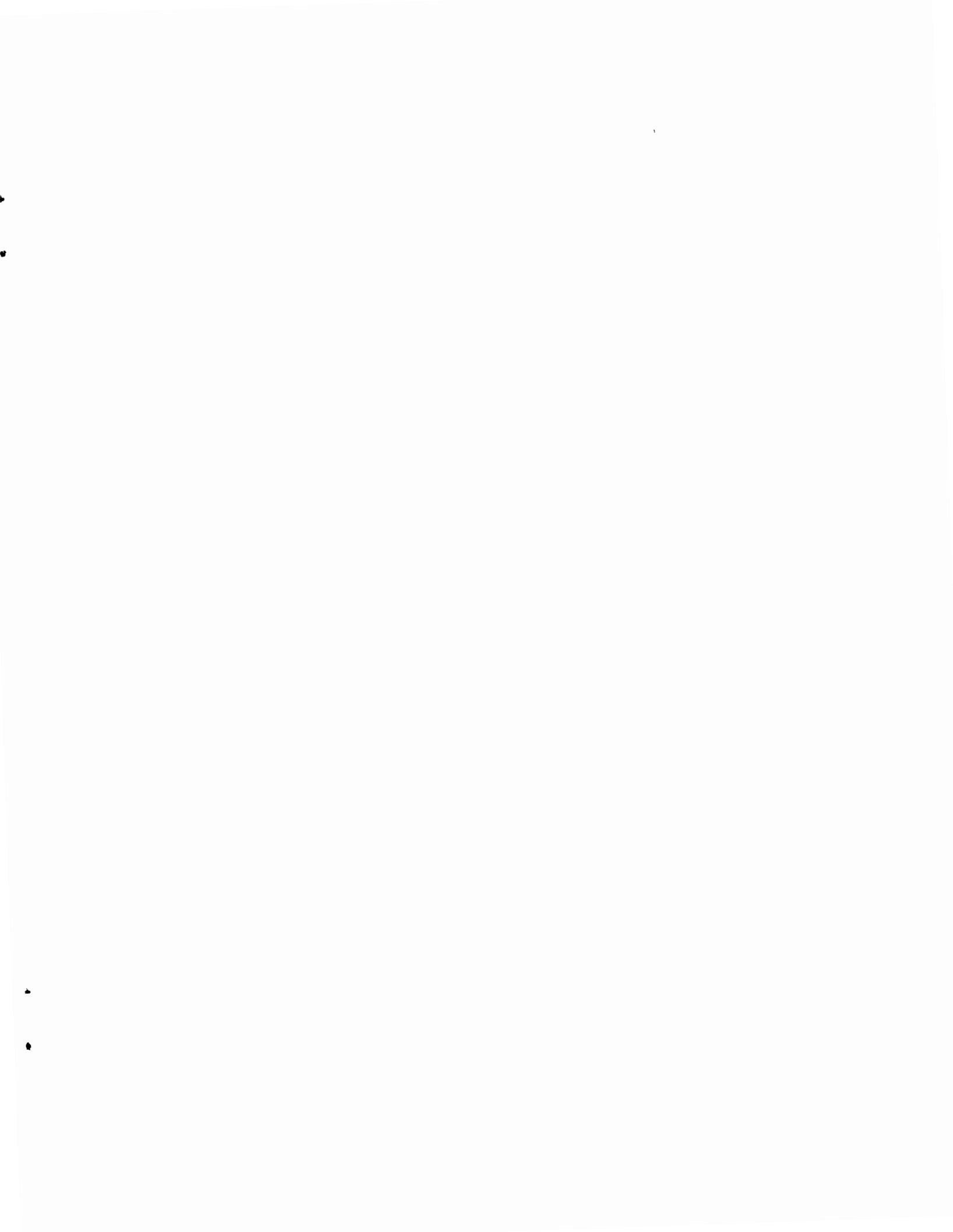

A P P E N D I X

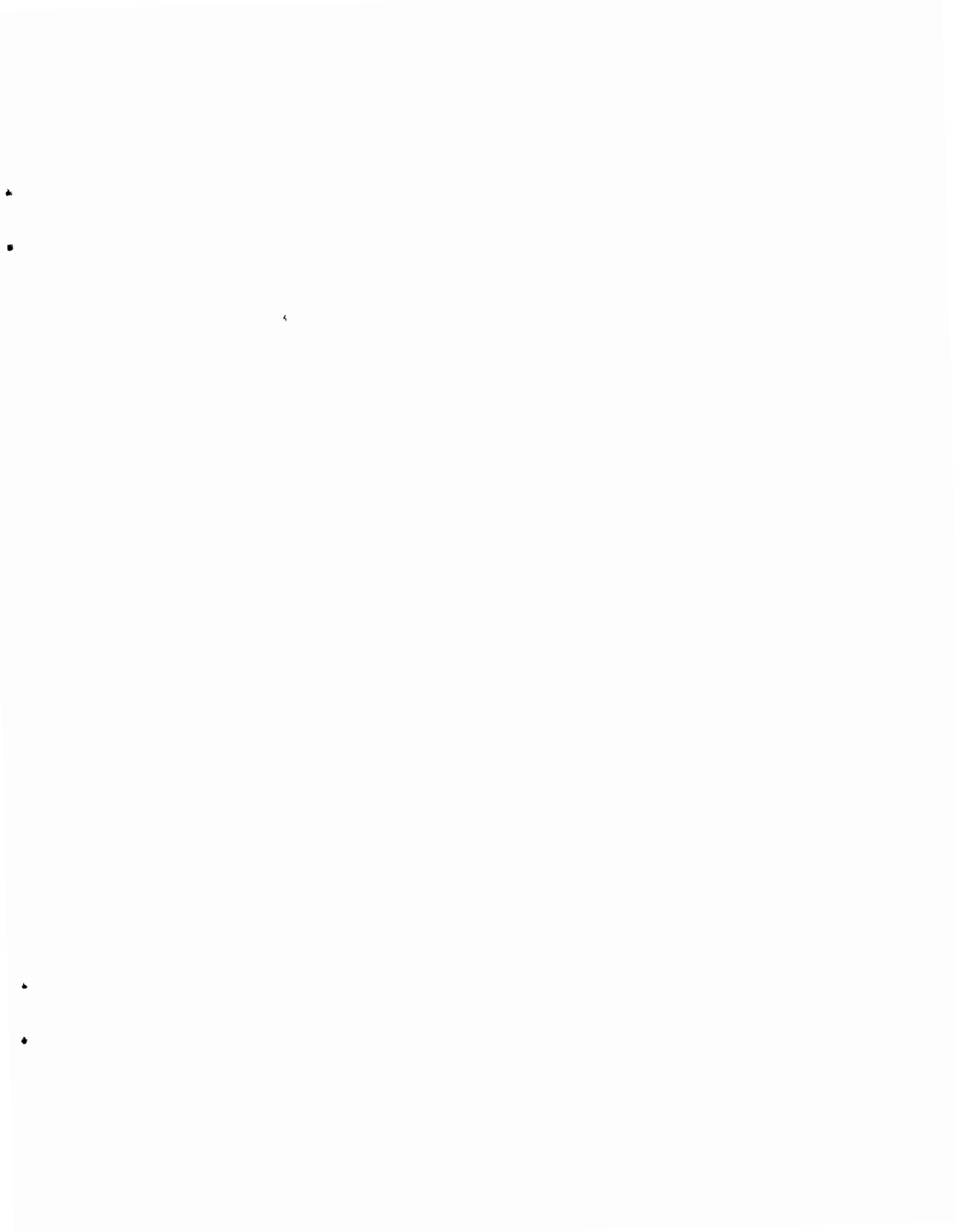

**2-WIRE EMERGENCY CALL SYSTEM
I-287 TEST SECTION
1970, 1971 FIELD SURVEY**

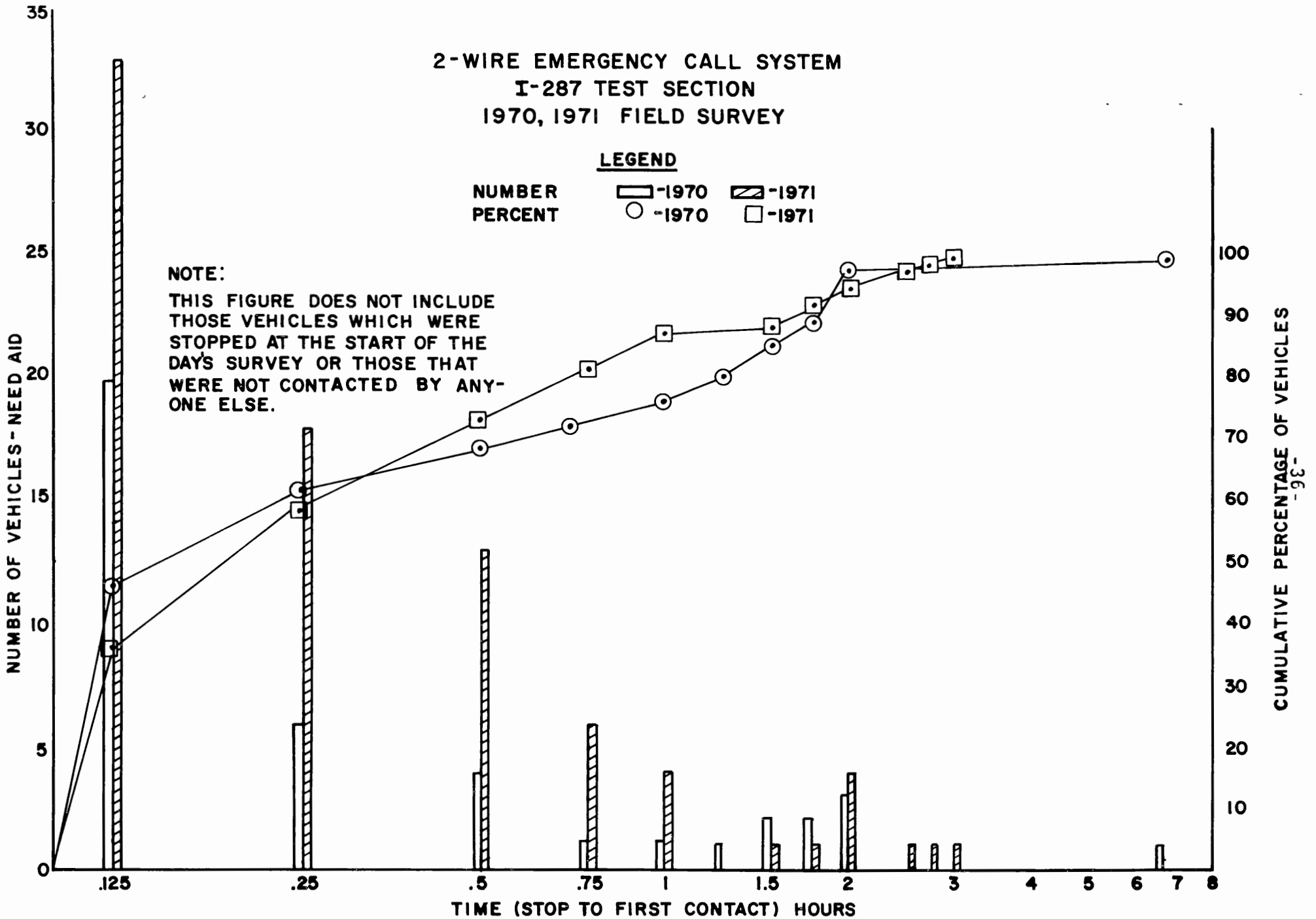

FIGURE 10

**2-WIRE EMERGENCY CALL SYSTEM
I-287 TEST SECTION
1970, 1971 FIELD SURVEY**

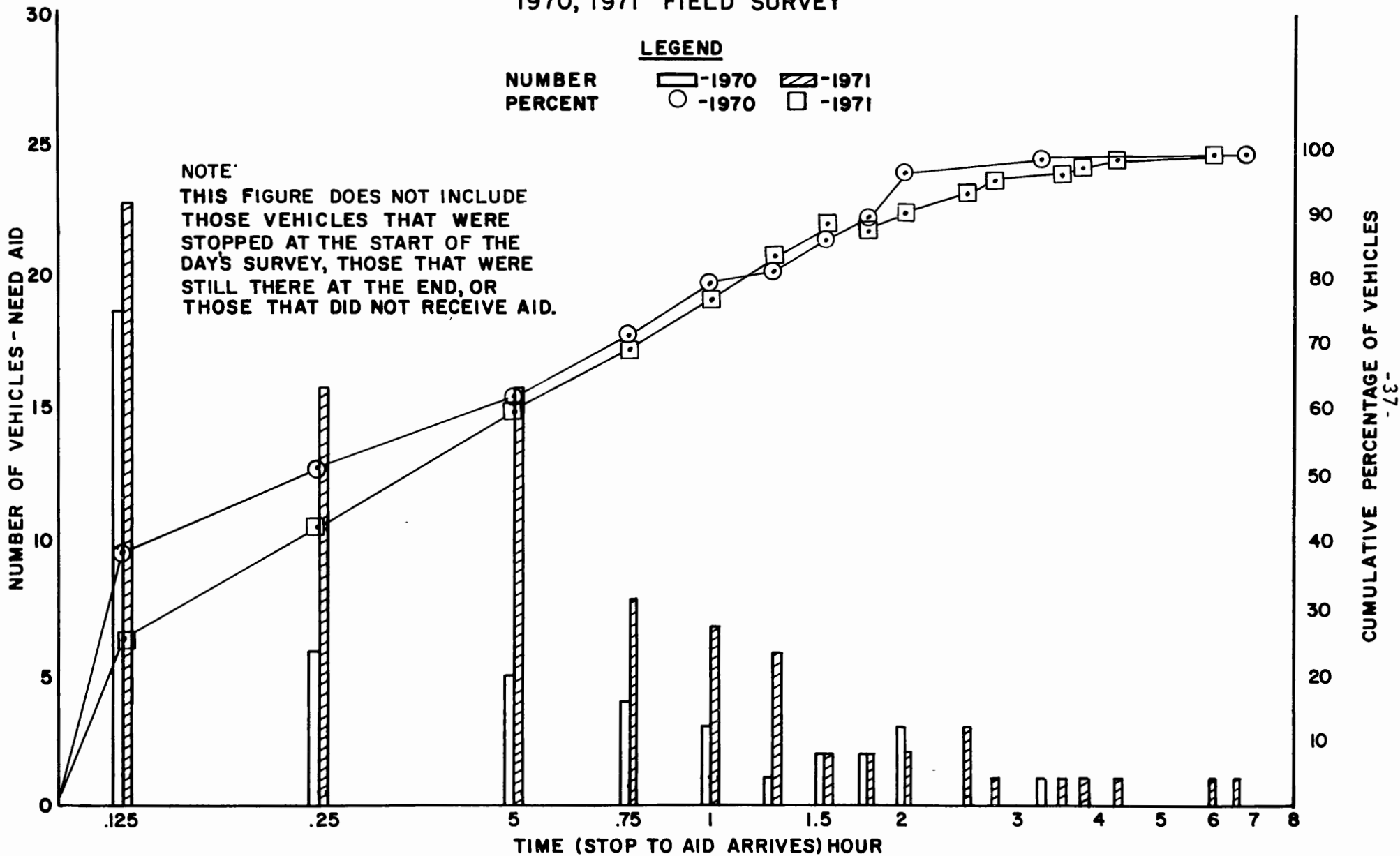

FIGURE II

**2-WIRE EMERGENCY CALL SYSTEM
I-287 TEST SECTION
1970, 1971 FIELD SURVEY**

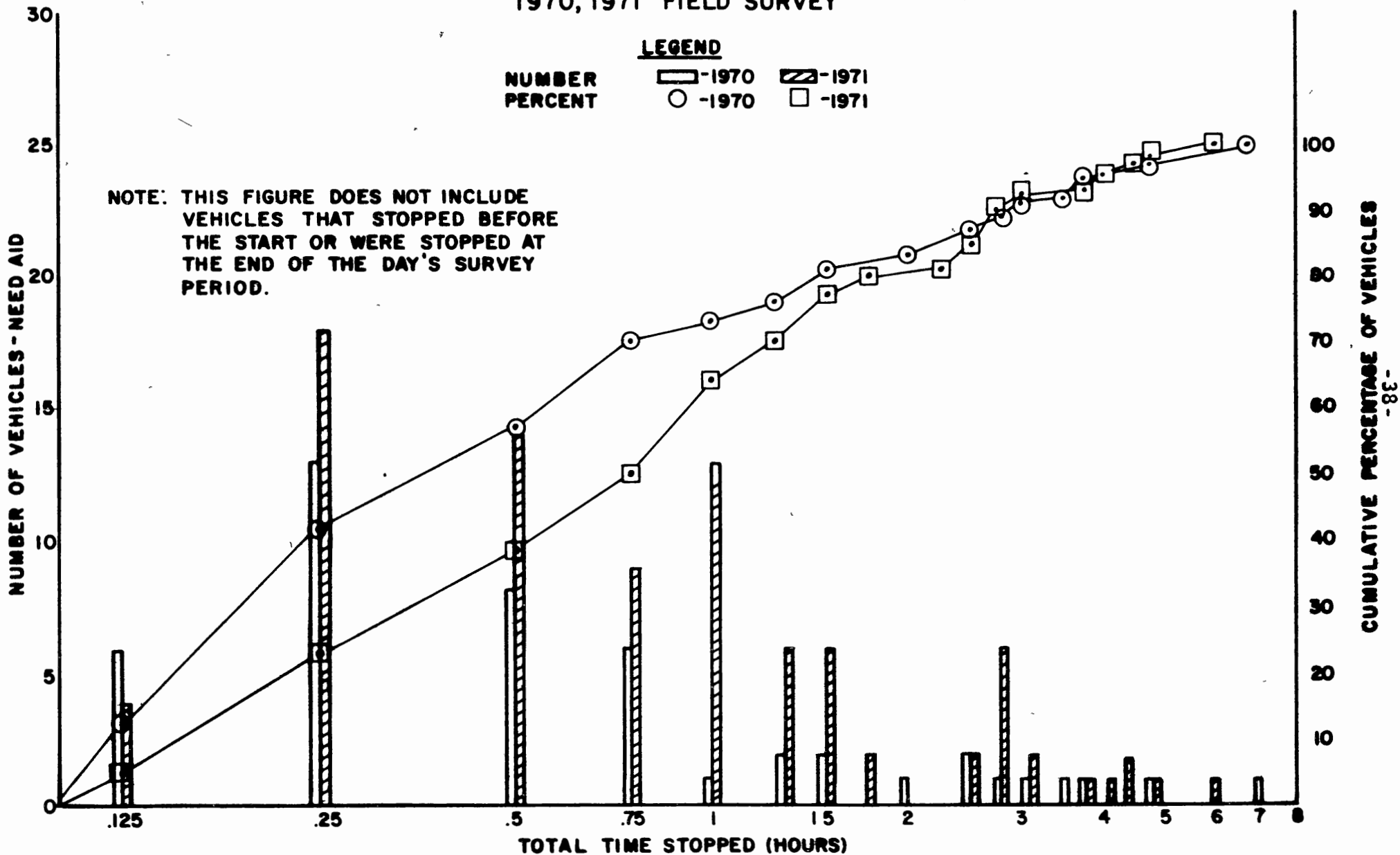

FIGURE 12

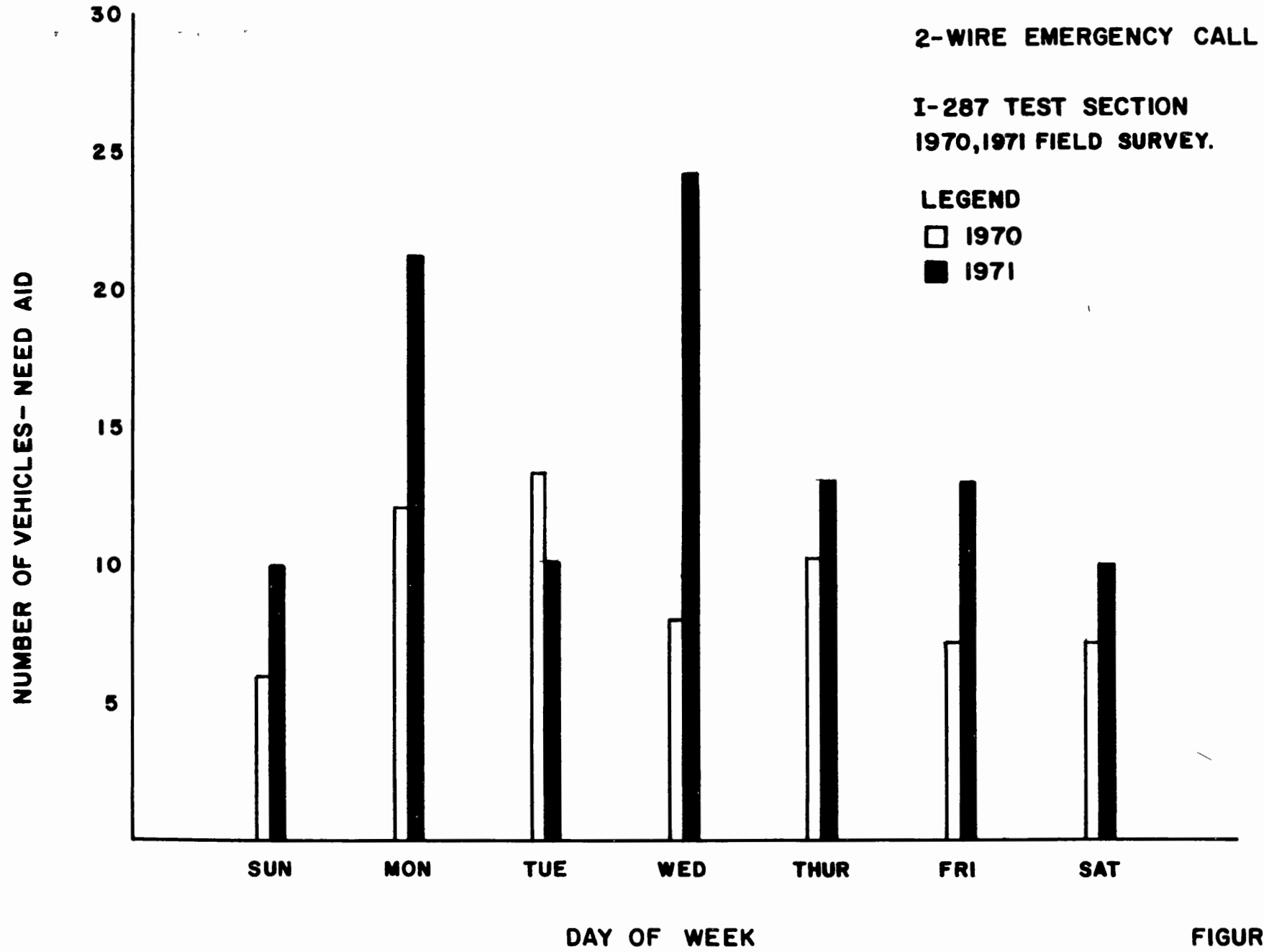

FIGURE 13

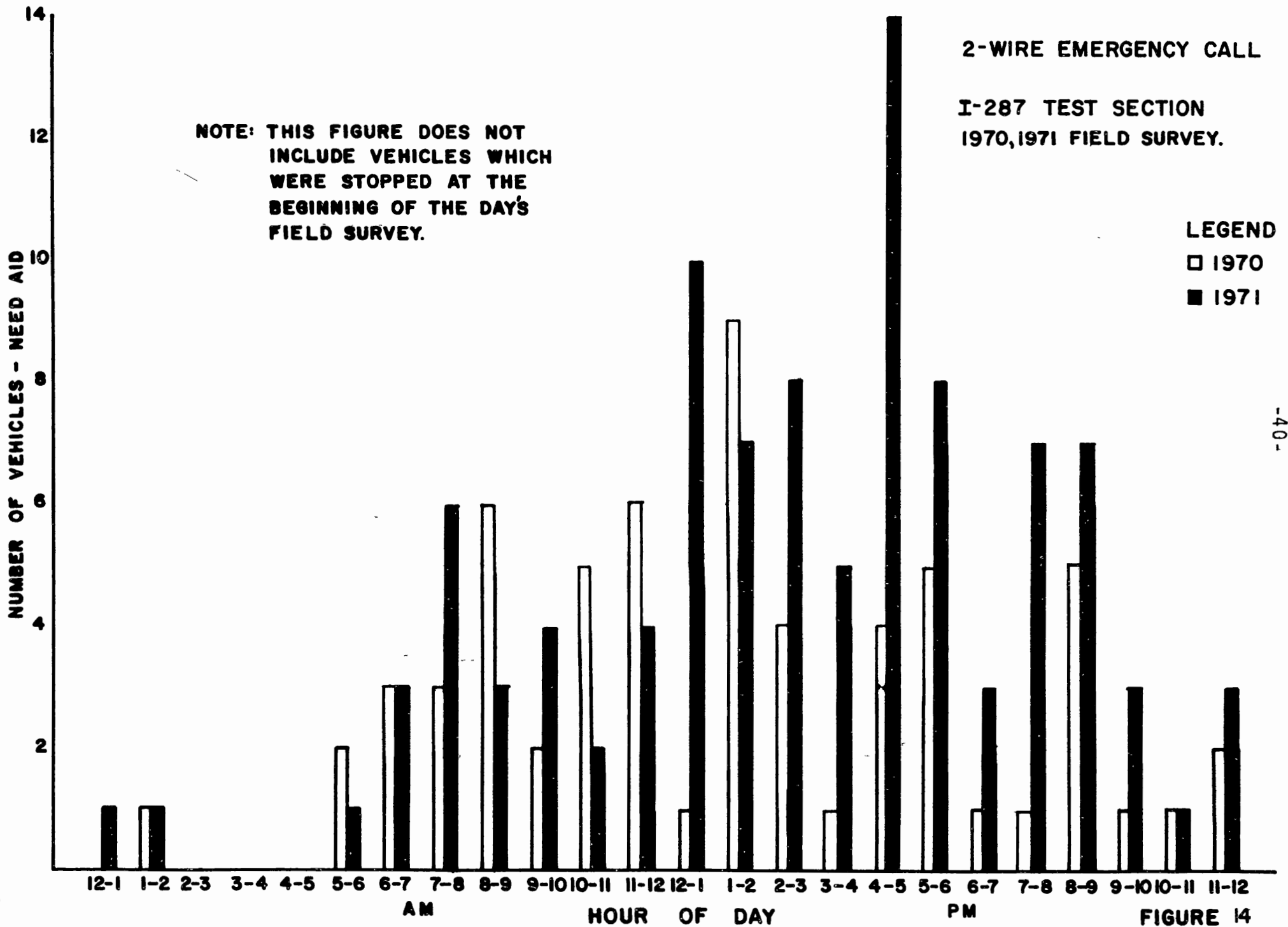

FIGURE 14

2-WIRE EMERGENCY CALL
 USE OF EMERGENCY CALL
 I-287 TEST SECTION
 1971 FIELD SURVEY

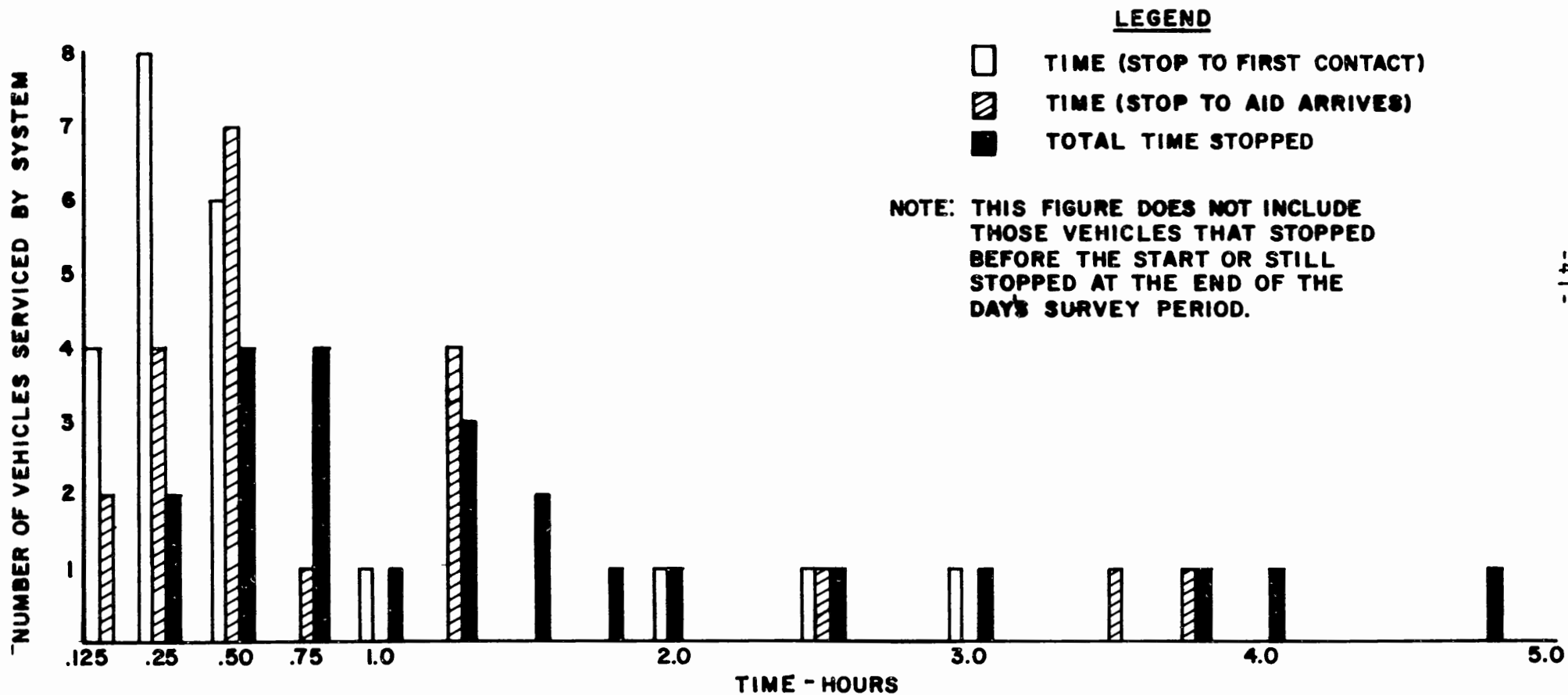

FIGURE 15

-42-
**2-WIRE EMERGENCY CALL
 USE OF EMERGENCY CALL
 I-287 TEST SECTION
 JULY - AUGUST 1971**

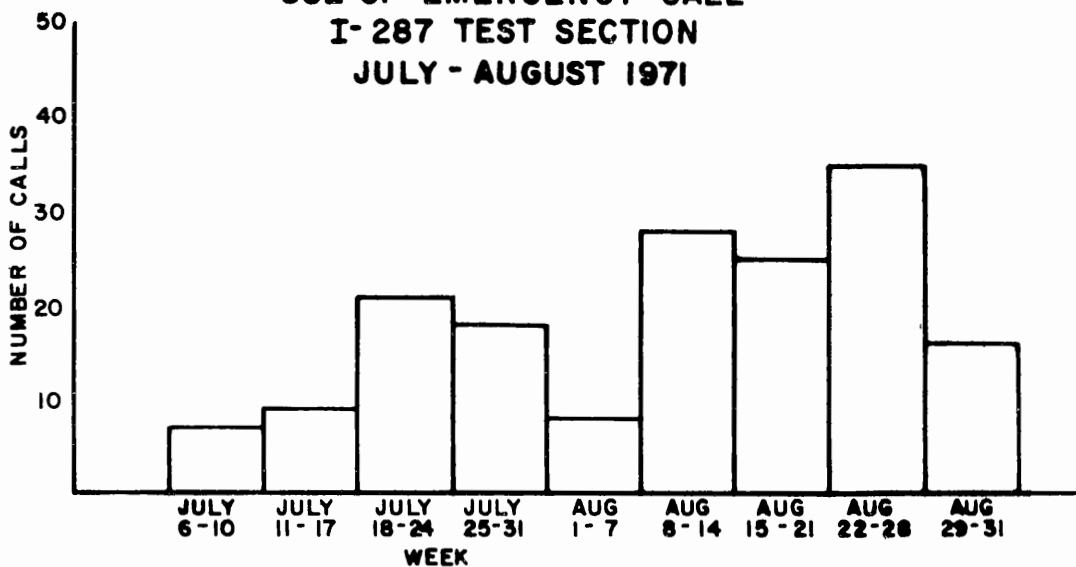

FIGURE 16

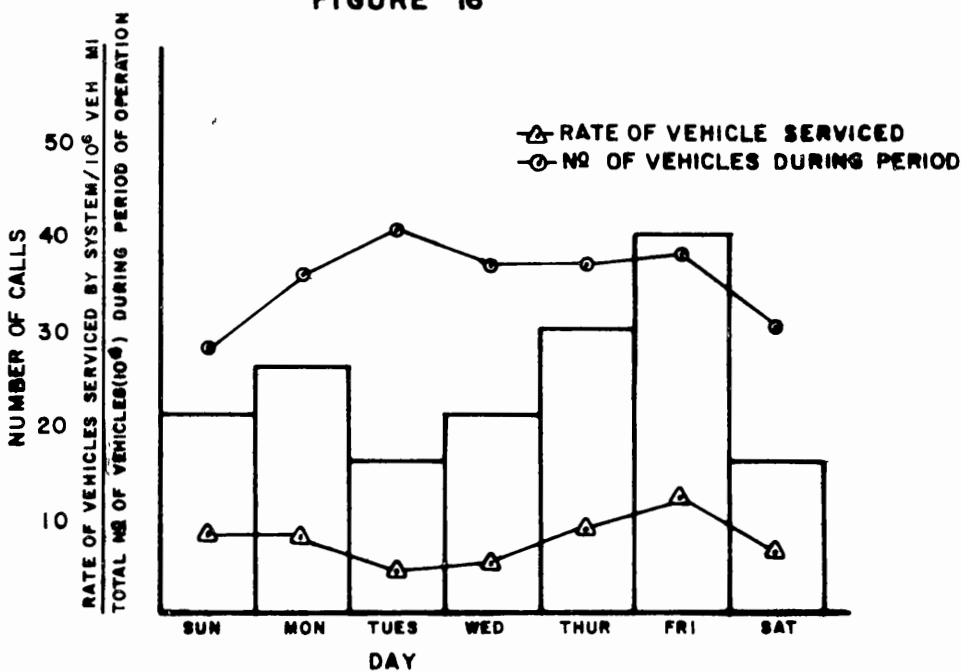

FIGURE 17

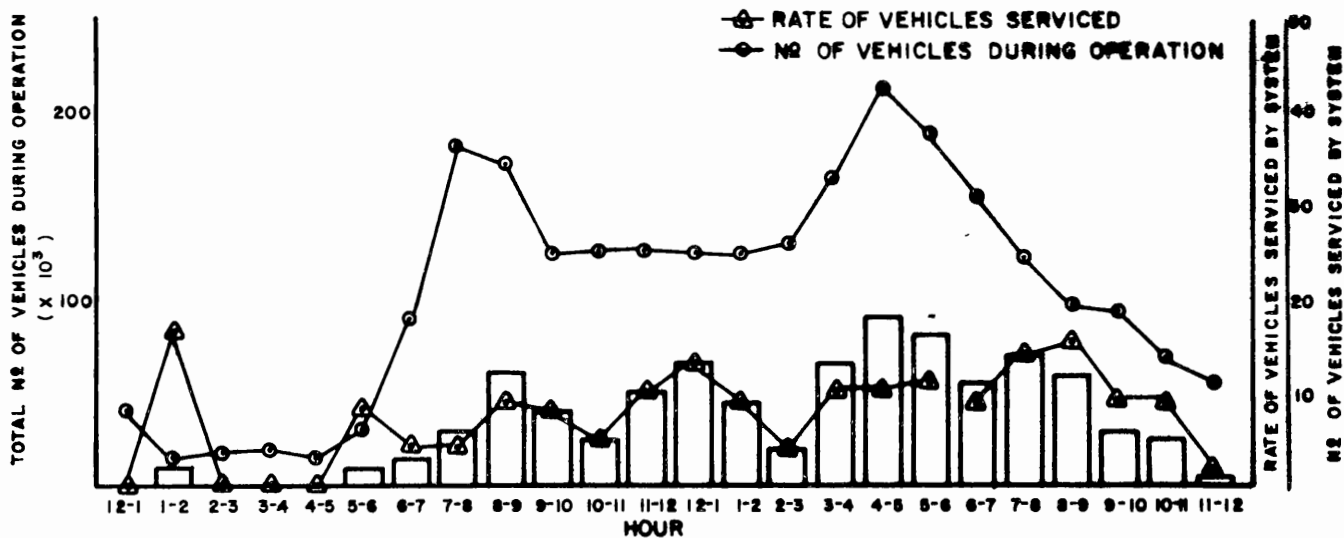

FIGURE 18

