

WATER POLLUTION CONTROL ACT**CHAPTER 14****WATER POLLUTION CONTROL ACT****Authority**

N.J.S.A. 13:1D-9, 58:10A-1 et seq., 58:10A-21 et seq.,
58:11-49 et seq., 58:11-64 et seq., 58:1A-1 et
seq., P.L. 1988, c.56, 57 and 63.

Source and Effective Date

R.1994 d.256, effective April 27, 1994.
See: 26 N.J.R. 1038(a), 26 N.J.R. 2459(a).

Executive Order No. 66(1978) Expiration Date

Chapter 14, Water Pollution Control Act, expires on April 27, 1999.

Chapter Historical Note

Unless otherwise expressly noted, all provisions of this chapter were adopted pursuant to authority of N.J.S.A. 58:10A-1 and were filed and became effective on July 27, 1977, as R.1977 d.268. See: 9 N.J.R. 259(a), 9 N.J.R. 418(c). Pursuant to Executive Order No. 66(1978), Chapter 14 was readopted as R.1989 d.282, effective April 27, 1989. See: 21 N.J.R. 373(a), 21 N.J.R. 1530(a). Notice of Action on Petition to amend New Jersey Pollution Discharge Elimination System permits. See: 23 N.J.R. 622(b). Public Notice: Opportunity for interested party review for rule amendment. See: 25 N.J.R. 411(a).

Pursuant to Executive Order No. 66(1978), Chapter 14 was readopted as R.1994 d.256. See: Source and Effective Date. See, also, Subchapter Historical Notes and section annotations.

Law Review and Journal Commentaries

Limitations on state agency authority to adopt environmental standards more stringent than federal standards: Policy considerations and interpretive problems. Jerome M. Organ, 54 Md.L.Rev. 1373 (1995). WESTLAW cite: 54 MDLR 1373.

RESEARCH NOTE

The Water Quality Regulations of the Interstate Sanitation Commission appear as Appendix A to Title 7.

CHAPTER TABLE OF CONTENTS**SUBCHAPTER 1. (RESERVED)****SUBCHAPTER 2. CONSTRUCTION OF WASTEWATER TREATMENT FACILITIES**

- 7:14-2.1 Construction procedures
- 7:14-2.2 Record drawings; collector sewers, interceptor sewers and force mains
- 7:14-2.3 Permits
- 7:14-2.4 Easements/rights-of-way
- 7:14-2.5 Field layout (baseline and monuments)
- 7:14-2.6 Engineer design activities: plan scale and plan updating
- 7:14-2.7 Construction, overhead and profit factors for Extra Work compensation
- 7:14-2.8 Payments to contractors
- 7:14-2.9 Mobilization: unit price contracts for sewer construction
- 7:14-2.10 Bid items for sewer pipe installation
- 7:14-2.11 Reasonable minimum unit prices
- 7:14-2.12 Payment widths, trench backfill and roadway paving for federally funded sewer projects
- 7:14-2.13 Excavation material unacceptable or conditionally acceptable for reuse as trench backfill

- 7:14-2.14 Construction equipment costs compensation for extra work
- 7:14-2.15 Substantial and final completion of pipe projects; contractor's guarantees

SUBCHAPTER 3. (RESERVED)**SUBCHAPTER 4. SLUDGE QUALITY ASSURANCE**

- 7:14-4.1 Scope
- 7:14-4.2 Purpose
- 7:14-4.3 Definitions
- 7:14-4.4 Analytical procedures
- 7:14-4.5 Reporting categories
- 7:14-4.6 Sampling procedures
- 7:14-4.7 Reporting requirements
- 7:14-4.8 Access
- 7:14-4.9 Non-compliance
- 7:14-4.10 Implementation
- 7:14-4.11 Exemptions and reductions in reporting requirements
- 7:14-4.12 Severability
- 7:14-4.13 through 7:14-4.21 (Reserved)

SUBCHAPTERS 5 THROUGH 7. (RESERVED)**SUBCHAPTER 8. CIVIL ADMINISTRATIVE PENALTIES AND REQUESTS FOR ADJUDICATORY HEARINGS**

- 7:14-8.1 Authority and purpose
- 7:14-8.2 Definitions
- 7:14-8.3 Procedures for assessment, payment and settlement of civil administrative penalties, and affirmative defenses
- 7:14-8.3A Public comment on interim enforcement limits
- 7:14-8.4 Procedures to request an adjudicatory hearing to contest an administrative order, a notice of civil administrative penalty assessment or a notice of civil administrative cost assessment; procedures for conducting adjudicatory hearings
- 7:14-8.5 Civil administrative penalty determination
- 7:14-8.6 Civil administrative penalty for submitting inaccurate or false information
- 7:14-8.7 Civil administrative penalty for failure to allow lawful entry and inspection
- 7:14-8.8 Civil administrative penalty for conducting unapproved activities
- 7:14-8.9 Civil administrative penalty for failure to properly conduct monitoring or sampling under the Water Pollution Control Act or the New Jersey Underground Storage of Hazardous Substances Act
- 7:14-8.10 Civil administrative penalty for failure to pay a fee
- 7:14-8.11 (Reserved)
- 7:14-8.12 Civil administrative penalty for violation of whole effluent toxicity limitations
- 7:14-8.13 Civil administrative penalty for economic benefit
- 7:14-8.14 Civil administrative penalty for failing to comply with an information request or administrative subpoena, and the destruction of records
- 7:14-8.15 (Reserved)
- 7:14-8.16 Civil administrative penalty determination for indirect dischargers
- 7:14-8.17 Enforcement actions for failure to implement an approved industrial pretreatment program
- 7:14-8.18 Severability

APPENDIX A DEP LABORATORY METHODS

APPENDIX B DOMESTIC WASTEWATER SLUDGE REPORT

APPENDIX C PRIORITY POLLUTANTS

APPENDIX A-1 SLUDGE REPORT

APPENDIX A-2 HEAVY METALS AND SELECTED CHEMICAL PARAMETERS

APPENDIX A-3 TOXIC ORGANIC COMPOUNDS REPORT

APPENDIX A-4 INDUSTRIAL PROCESS WASTEWATER SLUDGE REPORT

APPENDIX A-5 PRETREATMENT FACILITIES FACT PROFILE

APPENDIX B-1 HEAVY METALS AND TOXIC ORGANIC COMPOUNDS

APPENDIX B-2 TOXIC POLLUTANTS

APPENDIX B-3 POLLUTANTS THAT ARE INHIBITORY TO BIOLOGICAL TREATMENT PROCESSES

APPENDIX C SEPARATION OF LIQUID AND SOLID PHASES FOR ANALYSIS OF INORGANIC AND ORGANIC COMPONENTS

APPENDIX D WORDING OF FINANCIAL ASSURANCE DOCUMENTS

SUBCHAPTER 1. (RESERVED)

Subchapter Historical Note

Subchapter 1, originally adopted pursuant to authority of N.J.S.A. 58:10A-1, and which was filed and became effective on July 27, 1977 as R.1977 d.268, contained general provisions under the Water Pollution Control Act. See: 9 N.J.R. 259(a), 9 N.J.R. 418(c). This subchapter was repealed by R.1981 d.84, effective March 6, 1981. See: 12 N.J.R. 569(f), 13 N.J.R. 194(c).

SUBCHAPTER 2. CONSTRUCTION OF WASTEWATER TREATMENT FACILITIES

Subchapter Historical Note

Subchapter 2 originally contained rules on "Approval of Facilities for Prevention, Collection, Treatment or Discharge of Pollutants", filed on July 27, 1977 as R.1977 d.268. See: 9 N.J.R. 418(c). Amendments were filed on January 29, 1980 as R.1980 d.49 and on February 1, 1980 as R.1980 d.58. See: 12 N.J.R. 112(c), 12 N.J.R. 113(a). On March 6, 1981, R.1981 d.84, recodified this subject matter at N.J.A.C. 7:14A-12. See: 13 N.J.R. 194(c).

Subchapter 2, Construction of Wastewater Treatment Facilities, was adopted as R.1982 d.338, effective October 18, 1982. See: 14 N.J.R. 75(a), 14 N.J.R. 1155(b), 15 N.J.R. 440(b).

7:14-2.1 Construction procedures

The Division shall require and adhere to the procedures identified in this section. Actions or procedures by owners, permittees, consultants, contractors, or other persons affected by this chapter which are not in accordance with this subchapter shall not be acceptable to the Division. Where applicable, the Division may grant a waiver from any requirement of this subchapter upon presentation of written justification by the owner, permittee, consultant or contractor.

7:14-2.2 Record drawings; collector sewers, interceptor sewers and force mains

(a) The owner shall be responsible for the preparation of all record drawings required for sewer lines. This responsibility may be delegated to the owner's representative with adequate compensation for this service.

(b) This responsibility shall not be delegated or transferred to the contractor. The contractor shall assist the owner/engineer, by providing record information, when requested, during the progress of the work.

7:14-2.3 Permits

(a) Federal, State, county and municipal permits required as a result of the construction activity within the delineated site shall be obtained by the owner and associated fees shall be paid by the owner. In addition, permits required for construction activities on railroad properties shall be obtained by the owner.

(b) Exceptions to this section shall be a permit to use explosives for rock excavation and such other permits which by law are required to be obtained by the contractor.

(c) The owner shall make every reasonable effort to identify permits and fees and costs required as a result of the construction activity in effect 60 days prior to the receipt of construction bids. This responsibility may be delegated to the owner's engineer with adequate compensation for this service. The engineer shall be held harmless from any penalty or action resulting from the failure to obtain a permit where every reasonable effort has been made by the engineer to obtain such permits. Conditions made a part of any permit shall be imposed upon the contractor as described in the contract or bid documents. Additional costs associated with a permit resulting from the construction activity which is beyond that stipulated in the contract shall be the responsibility of the contractor.

(d) Whenever necessary or appropriate the contractor shall assist the owner in the acquisition of permits.

(e) The Department may intercede and assist in the resolution of any problems resulting from the acquisition of any permits.

7:14-2.4 Easements/rights-of-way

An interruption of construction or an extension of contract time may be a basis for a claim by a contractor for additional cost when such interruption or extension is caused by the owner's inability to obtain an easement/right-of-way. Claims shall include any reasonable cost incurred by the contractor and shall be reviewed and approved by the owner prior to submission to the Department. The Department may approve all, any portion, or deny the cost for eligibility for projects funded under the Grant Program.

7:14-2.5 Field layout (baseline and monuments)

The owner shall be responsible to establish and confirm field controls prior to start of construction. The contractor shall not be liable to check the accuracy of field controls (baseline and monuments) for sewer pipe installation. However, the contractor's layout must be based on a minimum of two field control points. Whenever the contractor detects an error in the field controls during pipe installation, the contractor shall immediately notify the owner and the owner's engineer of such error with sufficient documentation. The contractor shall be held responsible for all corrective measures and associated costs for failure to notify the owner of such error.

7:14-2.6 Engineer design activities: plan scale and plan updating

(a) On occasion, projects do not go to construction within a reasonable time after the bid advertisement. During this period, utilities may be relocated or installed, as well as other changes which can take place that are unknown to the contractor. Because of this, problems can take place during construction and result in numerous change orders and increases in the cost of the project.

(b) The horizontal scale for construction plans for sewerage facilities shall not be less than one inch equals 100 feet. A larger horizontal scale shall be used where appropriate to show sufficient detail to construct the project. The vertical scale for construction plans for sewerage facilities shall be not less than one inch equals 10 feet. Based upon the best information available, the location of underground utilities and support structures for overhead utilities shall be shown on the plans.

(c) Construction plans for sewerage facilities shall be updated whenever the bid advertisement date exceeds one year after approval by the responsible State or Federal regulatory agency. The engineer shall receive adequate compensation for updating plans and specifications. All such revisions shall be noted and dated on the plans prior to bid.

7:14-2.7 Construction, overhead and profit factors for Extra Work compensation

(a) The contractor is entitled to all identifiable direct job costs associated with Extra Work excluding subcontractor's

costs. For Extra Work not in excess of \$10,000 the contractors may add up to 10 percent overhead factor to their identifiable direct job costs, but excluding the cost of any subcontracting, plus up to a 10 percent profit factor to their identifiable direct costs plus overhead amount.

(b) As general policy, these overhead and profit factors may be accepted by owners as reasonable in lieu of requiring the submission of additional supporting data. However, the owner must reserve its right to review any cost or profit element on a case-by-case basis, where the submission for overhead and profit is in excess of the 10 percent overhead and 10 percent profit indicated above.

(c) Cost increase in subcontracted work may be similarly handled and a prime contractor may add up to 10 percent to the total cost (including overhead and profit factors) incurred by the subcontractor. In such cases, the same reservations for rights shall apply.

(d) For Extra Work in the amount of \$10,000 to \$100,000, the above factors may be included initially for equitable adjustments but will be subject to negotiation, cost and pricing data, and owner review requirements. Federally funded projects will be governed by Federal regulations.

7:14-2.8 Payments to contractors

(a) At least 20 days before each monthly progress payment falls due for approval (but not more often than once per month), the contractor will submit to the engineer a partial payment estimate filled out and signed by the contractor covering the work performed during the period covered by the partial payment estimate and supported by such data as the engineer may reasonably require. Where any specific item(s) in the partial payment estimate is in dispute, the engineer may delete those costs from the estimate and approve the acceptable portion of the payment request. Payment requested for stored materials and/or equipment shall be subject to the following conditions being met or satisfied:

1. The materials and/or equipment shall be received in a condition satisfactory for incorporation in the work.
2. The materials and/or equipment shall be stored in such manner that they will not be damaged due to weather, construction operations or any other cause.
3. An invoice from the supplier shall be furnished for each item on which payment is requested.
4. The contractor shall furnish written proof from the supplier of 90 percent payment for the materials and/or equipment no later than 30 days after receipt of payment for same from the owner. The owner shall have the right to deduct from the next payment estimate an amount equal to the payment for said material and/or equipment if reasonable and adequate proof is not submitted.

(b) The contractor warrants and guarantees that title to all work, materials, and equipment covered by an Application for Payment, whether incorporated in the project or not, will pass to the owner upon the receipt of such payment by the contractor free and clear of all lien, claims, security interests or encumbrances (except 10 percent retention which may be withheld from suppliers and subcontractors to guarantee completion and performance). The engineer will after receipt of each partial payment estimate either indicate in writing his approval of payment and present the partial payment estimate to the owner, or return the partial payment estimate to the contractor indicating in writing his reasons for refusing to approve payment. In the latter case, the contractor may make the necessary corrections and resubmit the partial payment estimate. The owner shall review the partial payment estimate at its next regularly scheduled meeting and, if approved, payment shall be made available to the contractor within five days. The owner shall retain not more than two percent of the amount of each payment claimed. In accordance with EPA regulations, prime contractors are also required to make prompt payment to subcontractors and suppliers for eligible construction, material, and equipment costs. Generally, payments of all valid subcontractor and supplier requests for payment should be satisfied prior to the next succeeding request for progress payment by the prime contractor.

(c) When the work is substantially complete (Operational or Beneficial Occupancy), the withheld amount shall be further reduced below two percent but not less than twice the current market value of the work yet to be completed. On completion and acceptance of a part of the work on which the price is stated separately in the Contract Documents, payment shall be made in full including retained percentages, less authorized deductions. The contractor or owner may request assistance and guidance from the Department on disputes regarding retainage.

(d) "Substantial completion" as used in the context of this section shall mean satisfactory completion of major portions of the contract work, including inspection and testing, so that the facility may be turned over to the owner for its intended use or occupancy. The engineer shall certify the date of substantial completion and that date shall establish the beginning date of the warranty/guarantee period unless a prior date has been established.

7:14-2.9 Mobilization: unit price contracts for sewer construction

(a) Mobilization shall consist of the cost of initiating the contract. Payment for mobilization will be made at the lump sum price bid for this item in the proposal, which price shall include the cost of initiating the contract. The provisions for payment for the item mobilization supersede any provisions elsewhere in the specifications for including the costs of these initial services and facilities in the prices bid for the various items scheduled in the proposal. The lump sum price bid for mobilization shall be payable to the contractor whenever he shall have completed 10 percent of the work of the contract. For the purposes of this item, 10 percent of the work shall be considered completed when the total of payments earned, exclusive of the amount bid for this item, shown on the monthly certificates of the approximate quantities of work done, shall exceed 10 percent of the total price bid for the contract.

(b) The lump sum price bid for mobilization is limited to the following maximum amounts:

Original Contract Amount (including Mobilization)		Maximum Amount for Item of Mobilization
From More Than	To and Including	
\$ 0	\$ 100,000	\$ 3,000
100,000	500,000	15,000
500,000	1,000,000	30,000
1,000,000	2,000,000	60,000
2,000,000	3,000,000	90,000
3,000,000	4,000,000	120,000
4,000,000	5,000,000	125,000
5,000,000	6,000,000	150,000
6,000,000	7,000,000	175,000
7,000,000	10,000,000	200,000
10,000,000	—	2.5% of Amount Bid

7:14-2.10 Bid items for sewer pipe installation

(a) This section establishes bid items which shall be included in unit price contracts for sewer pipe installation where applicable.

Description	Unit of Measure
1. Test Pits	Cubic Yard
2. Stone Foundation (bedding)	Cubic Yard
3. Select Material (below and above pipe grade)	Cubic Yard
4. Rock Excavation (including removal and disposal of boulders)	Cubic Yard
5. Wood Sheeting (install and remove where shown on plans)	Square Feet or 1000 Board Feet
6. Wood Sheeting (left in place where shown on plans)	Square Feet or 1000 Board Feet
7. Steel Sheeting (install and remove where shown on plans)	Square Feet or Tons

Description	Unit of Measure
8. Steel Sheeting (left in place where shown on plans)	Square Feet or Tons
9. Permanent Pavement Gravel	Square Yard
10. Pavement	
i. Municipal:	
(1) Temporary which shall be removed (where applicable)	Square Yard
(2) Base	Square Yard
(3) Top	Square Yard
ii. County:	
(1) Temporary which shall be removed (where applicable)	Square Yard
(2) Base	Square Yard
(3) Top	Square Yard
iii. State:	
(1) Temporary which shall be removed (where applicable)	Square Yard
(2) Base	Square Yard
(3) Top	Square Yard
11. Testing	Linear Feet
12. Concrete Cradle or Encasement (to be identified where applicable)	Cubic Yard

7:14-2.11 Reasonable minimum unit prices

(a) This section establishes reasonable minimum unit prices for indeterminate items, where applicable, for sewer pipe installation. Indeterminate items are those items which may be anticipated and for which quantities cannot be determined.

(b) The reasonable minimum unit prices are to be established by the owner/engineer for the following items:

1. Stone Foundation;
2. Select Material;
3. Concrete Cradle or Encasement—Nonreinforced;
4. Concrete Cradle or Encasement—Reinforced;
5. Test Pits;
6. Rock Excavation;
7. Wood Sheeting (install and remove)—square feet or 1000 board feet;
8. Wood Sheeting (left in place)—square feet or 1000 board feet;
9. Steel Sheeting (install and remove)—square feet or tons;
10. Steel Sheeting (left in place)—square feet or tons.

7:14-2.12 Payment widths, trench backfill and roadway paving for federally funded sewer projects

(a) This section establishes eligible payment widths for select fill used for trench backfill and roadway paving for federally funded sewer projects.

(b) Select trench backfill payment width:

1. Select trench backfill will be eligible for grant funding when the excavated material is totally or partially unacceptable for reuse as trench backfill. When the unacceptable material must be replaced with approved select backfill in a trench with a depth of 10 feet or less from the top of the pipe, the eligible payment width shall be Bd as shown below. For trenches of a greater depth the maximum eligible payment width shall be Bd plus H for the depth of unsuitable material as measured at the time of excavation.

2. When trench width is less than Bd plus H , the actual width shall control the payment.

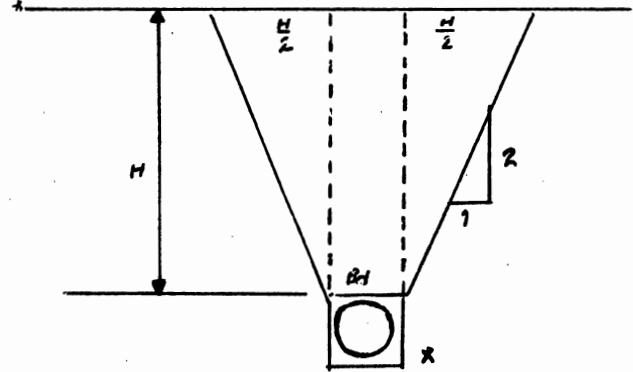

3. Bd equals Maximum trench width (measured at the top of the pipe) allowed by the engineer for the type and strength class of pipe being installed.

4. The owner/engineer must make every effort to minimize the use of select fill. Marginal backfill material (material which is not acceptable for use in the pipe envelope or as a subbase for roadways) will be limited to the midzone of the trench. The midzone is defined as that portion of the trench beginning two feet above the top of the pipe, after compaction of the pipe envelope, to a point two feet below the final road or easement elevation. The owner/engineer must make all final decisions concerning the above.

(c) Paving:

1. Maximum eligible payment width shall be the disturbed width plus two feet. In no case shall the maximum eligible payment width be greater than Bd plus H ;

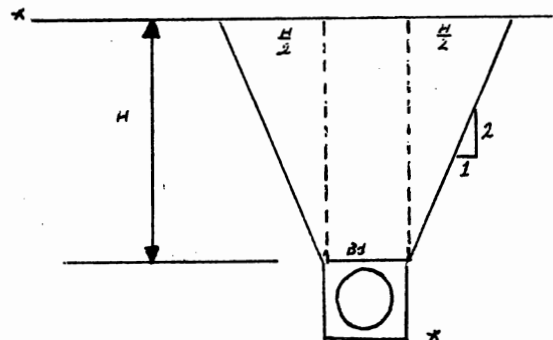

2. Maximum Eligible Pay Width equals Bd plus H ;

3. Special considerations:

i. Pavement replacement shall, in all instances, be "like kind" replacement except where the replacement of the original thickness of roadway material will not yield a structurally stable surface over the disturbed trench area, or where the requirements of the responsible governmental jurisdiction specify roadway materials other than the original disturbed pavement. In these instances, the engineer should specify the minimum thickness necessary to obtain a structurally sound surface or to comply with established local, county or State road opening permit requirements. Such requirements shall be contained in the contract documents.

ii. Roadways where the original total pavement thickness is less than two inches and the pavement cannot be boxed and maintained during construction, will be eligible for "like kind" replacement outside of the eligible trench pavement width.

iii. Any deviation from the above should be submitted during the design phase (Step II) for approval if possible. In all instances, approvals must be obtained prior to soliciting bids.

iv. Reducing the pavement thickness specified by the engineer and spreading it across a wider area of the street will not be approved unless extenuating circumstances justify the need to pave a wider area. These situations will be considered on a case by case basis and must be submitted as a Change Order and receive approval prior to implementing such a change.

(d) Application of this section will be mandatory for all Federal Grants awarded, pursuant to the provisions of the Federal Clean Water Act (33 U.S.C. 1251 et seq.) as amended, after the date of adoption of this subchapter.

7:14-2.13 Excavation material unacceptable or conditionally acceptable for reuse as trench backfill

(a) The following trench excavation materials are unacceptable as trench backfill:

1. Any excavation materials that will cause damage to the piping systems;
2. Any excavation material that cannot be compacted or consolidated to yield the desired density as specified in the contract specifications;
3. Trees, stumps and foreign material.

(b) The following excavation materials are conditionally acceptable as trench backfill only if provided for in the contract specifications and the trench is located in a right-of-way, an easement, a roadway or an unimproved area:

1. Clay, organics and silt determined to be suitable in accordance with soil tests required by the owner/engineer.

2. Hard materials, such as blacktop, concrete, stone and rock.

i. The hard materials shall only be placed in the midzone of the trench beginning two feet above the top of the pipe, after compaction of the pipe envelope, to a point two feet below the final road or ground surface.

ii. Placement of the hard materials shall not create a potential hazard to the pipe or create voids that will cause adverse settlement.

iii. The maximum overall size of any piece of hard material shall be 12 inches.

(c) The Department may require that all trench backfill material not conforming to this subsection and contract specifications be removed and spoiled to a spoil site approved by the Department in accordance with the requirements of N.J.A.C. 7:26-1, for solid or hazardous wastes.

R.1984 d.339, effective August 6, 1984.
See: 16 N.J.R. 1147(a), 16 N.J.R. 2102(b).

7:14-2.14 Construction equipment costs compensation for extra work

(a) The contractor is entitled to all identifiable direct job equipment costs associated with extra work. The compensable cost for construction equipment shall be based upon the most current costs established in "Rental Rates for Construction Equipment" and "Rental Rates for Older Construction Equipment" (Blue Book), Dataquest Incorporated, A.C. Nielsen Company, San Jose, CA, 1983.

(b) Overhead and profits factors allowed in N.J.A.C. 7:14-2.7, shall only be applied to the rates charged for rental equipment used by the contractor for extra work.

R.1984 d.339, effective August 6, 1984.
See: 16 N.J.R. 1147(a), 16 N.J.R. 2102(b).

7:14-2.15 Substantial and final completion of pipe projects; contractor's guarantees

(a) The contractor shall notify the owner/engineer in writing when the contract work is substantially complete as defined by N.J.A.C. 7:14-2.8(d). Within a reasonable time, the owner/engineer shall inspect the work.

(b) If the owner/engineer considers the work to be substantially complete, and before the Certificate of Substantial Completion is issued, the contractor shall:

1. Submit a construction schedule for the remaining work to be completed, and
2. Warrant and guarantee, for a period of one year or for a period as otherwise specified, from the date of Substantial Completion, that the completed work is free from defects due to faulty materials, equipment or workmanship. The Performance Bond shall remain in effect through the guarantee period.

(c) If the owner/engineer does not consider the work to be substantially complete, the engineer shall notify the contractor in writing, listing the items to be completed or corrected.

1. The contractor shall correct or complete items identified in writing within a reasonable time as specified in the contract documents, including repairs of any damage resulting from such defects to other work completed under the contract.

2. If the contractor fails to make such corrections within a reasonable time as specified in the contract documents, the owner may do so and charge the costs incurred, including direct and indirect costs, to the contractor.

(e) Before the Contractor has received notification of substantial completion, the owner/engineer may submit a request to the contractor to use a functional portion of the work if:

1. Such use does not significantly interfere with construction on any portion of remaining work to be completed, and

2. The conditions of such use shall be identified in the Certificate of Substantial Completion when issued by the owner/engineer.

(f) Final completion shall be that point at which the contract is completed, defective work corrected and clean up work accomplished. Unless a Certificate of Substantial Completion has been issued, the guarantee period shall begin upon certification of final completion by the engineer.

R.1984 d.339, effective August 6, 1984.
See: 16 N.J.R. 1147(a), 16 N.J.R. 2102(b).

SUBCHAPTER 3. (RESERVED)

Subchapter Historical Note

Subchapter 3, originally adopted pursuant to N.J.S.A. 58:10A-1, and which was filed and became effective on July 27, 1977 as R.1977 d.268, contained information concerning NJPDES permits under the Water Pollution Control Act. This subchapter was repealed by R.1981 d.84, effective March 6, 1981. See: 12 N.J.R. 569(f), 13 N.J.R. 194(c).

SUBCHAPTER 4. SLUDGE QUALITY ASSURANCE

Subchapter Historical Note

Unless otherwise expressly noted, all provisions of this subchapter were adopted pursuant to authority of N.J.S.A. 13:1D-9(c), 58:10A-1 and 58:11-51 and were filed and became effective on October 18, 1979, as R.1979 d.419. See: 11 N.J.R. 274(d), 11 N.J.R. 544(e). Petition for Rulemaking. See: 23 N.J.R. 622(c).

7:14-4.1 Scope

The following shall constitute the rules for sludge quality assurance reporting required of all domestic and industrial treatment works. The rules prescribe the method and frequency for reporting on the quantity, quality and management method of sludge generated by such treatment works.

Amended by R.1989 d.282, effective June 5, 1989.
See: 21 N.J.R. 373(a), 21 N.J.R. 1530(a).

N.J.A.C. 7:14-4.1 was originally entitled "Authority" and was repealed and replaced with N.J.A.C. 7:14-4.2 recodified to this cite and amended regarding pretreatment works and substituting the word rule for regulation.

7:14-4.2 Purpose

(a) The rules in this subchapter are promulgated for the following purposes:

1. To determine the degree of chemical contamination, including metals and organic compounds present in sludge produced by domestic and industrial treatment works;

2. To establish a data system providing information for a program to reduce the discharge of toxic levels of pollutants into the waters of the State; and

3. To establish a data system providing information for environmentally sound sludge management.

Amended by R.1989 d.282, effective June 5, 1989.
See: 21 N.J.R. 373(a), 21 N.J.R. 1530(a).

Recodified from N.J.A.C. 7:14-4.3 and amended adding language regarding rules in subchapter and deleting reference to "utilization and disposal" and substituting "management".

7:14-4.3 Definitions

The following words and terms, when used in this subchapter, shall have the following meanings unless the context clearly indicates otherwise. Unless otherwise specified below, all words and terms shall be as defined in "The New Jersey Pollutant Discharge Elimination System", N.J.A.C. 7:14A.

"BOD" (biochemical oxygen demand) means the quantity of dissolved oxygen (in milligrams per liter) required during stabilization of decomposable organic matter by aerobic biochemical action as determined by analytical procedures set forth in the "Manual of Methods for Chemical Analysis of Water and Wastes", USEPA, Office of Technology Transfer, Washington, D.C., March 1983.

"COD" (chemical oxygen demand) means the quantity of dissolved oxygen (in milligrams per liter) required to oxidize the organic matter in a waste sample under specific conditions of oxidizing agent, temperature and time as determined by analytical procedures set forth in the "Manual of Methods for Chemical Analysis of Water and Wastes", USEPA, Office of Technology Transfer, Washington, D.C., March 1983.

“Domestic pollutant” means a pollutant which results from the discharge of household, commercial or other wastes from bathrooms, toilet facilities, home laundries and kitchens which are predominantly the result of natural human waste elimination associated with bodily function and food preparation.

“Domestic treatment works” (DTW) means all publicly owned treatment works as well as any privately owned treatment works processing primarily domestic wastewater and pollutants together with any ground water, surface water, storm water or process wastewater that may be present.

“Domestic wastewater” means the liquid waste or liquid borne wastes discharged into a domestic treatment works.

“Domestic wastewater sludge” means the solid residue and associated liquids resulting from the physical, chemical or biological treatment of domestic wastewaters by a domestic treatment works.

“Effluent” means the treated liquids which are discharged by a domestic or industrial treatment works.

“Industrial treatment works” means a treatment works which treats primarily process wastewater and/or industrial pollutants as determined by the percentage of process wastewater, or mass loading of BOD, COD or suspended solids in the wastewater flow. Industrial treatment works shall also include any treatment works whether publicly or privately owned which treats primarily wastewater or leachate from a municipal solid waste facility or a potable water treatment plant. This definition shall also encompass SIU pretreatment works.

“MGD” means million gallons per day.

“Permit-by-rule discharger” means an indirect discharger regulated pursuant to N.J.A.C. 7:14A-13.5.

“Permitted flow” means a treatment work’s maximum allowable flow (in MGD) as stated in the facility’s NJPDES Permit.

“Pretreatment” means applications of physical, chemical and/or biological processes to reduce the amount of pollutants in, or alter the nature of the polluting properties of a process wastewater prior to discharging such wastewater into the domestic treatment works.

“Process wastewater” means any water which, during manufacturing or processing, comes into direct contact with or results from the production or use of any raw material, intermediate product, finished product, byproduct, or waste product.

“Process wastewater sludge” means the solid residue and associated liquid resulting from the physical, chemical and/or biological treatment of process wastewaters by an industrial treatment works.

“Publicly owned treatment works” (“POTW”) means any device or system used in the treatment (including recycling and reclamation of municipal sewage or industrial wastes of a liquid nature which is owned by a State or municipality. This definition includes sewers, pipes, or other conveyances only if they convey wastewater to a POTW providing treatment. However, despite public ownership of potable water treatment plants and solid waste facilities which may provide for treatment and/or discharge of pollutants, treatment works associated with potable water treatment and solid waste facilities shall be considered industrial treatment works for the purpose of this chapter.

“Significant indirect user” (“SIU”) means, solely for the purposes of this subchapter, any user, excluding municipal collection systems, who discharges on any one day wastewater into a domestic treatment works where:

1. The volume of process wastewater exceeds 25,000 gallons per day;
2. The amount of BOD, COD or suspended solids in the process wastewater discharge exceeds the mass equivalent of 25,000 gallons per day of the domestic waste of the affected domestic treatment works;
3. The volume of process wastewater in the discharge exceeds five percent or more of the average daily flow of the domestic treatment works;
4. The discharge of process wastewater contributes, prior to any pretreatment, five percent or more of the daily mass loading of any of the pollutants listed in N.J.A.C. 7:14A, Appendix B Tables II-IV;
5. The user of a domestic treatment works is determined to be a hazardous waste facility under N.J.A.C. 7:26-12 and meets the requirements of N.J.A.C. 7:14A-4.2(b)1;
6. The user is determined to be an industrial waste management facility under N.J.A.C. 7:14A-4;
7. The user has been found by the Department to be in violation of State laws or rules, or local ordinances concerning environmental issues;
8. The discharge consists of landfill leachate, either pure, treated or diluted by groundwater or surface runoff;
9. The discharge consists of significant quantities of polluted groundwater which is pumped from the ground in order to decontaminate an aquifer; or

10. The Department determines it would be consistent with the intent of the "Pretreatment Standards for Sewage", N.J.S.A. 58:11-49 et seq., or the "Water Pollution Control Act", N.J.S.A. 58:10A-1 et seq., to require a permit for the indirect discharger.

"SIU pretreatment works" means any treatment works serving exclusively a SIU facility and treating the facility's process wastewater, or a combination of its process wastewater and its domestic wastewater, prior to the discharge thereof into a domestic treatment works.

"Sludge" means the solid residue and associated liquid resulting from physical, chemical, and/or biological treatment of domestic or process wastewaters.

"Sludge quality criteria" means any restriction on quantities, quality, discharge rates, concentration of chemical, physical, thermal, biological, or other constituents of a pollutant in sludge based upon the method for ultimate management.

"Suspended solids" means total nonfilterable residue as determined by analytical procedures set forth in the "Manual of Methods for Chemical Analysis of Water and Wastes", USEPA, Office of Technology Transfer, Washington, D.C., March 1983.

"Treatment works" means any treatment works as defined by N.J.A.C. 7:14A-1.9 and N.J.S.A. 58:10A-3.

"Ultimate management" means final management of sludge at a facility or operation such that no additional permit or approval actions are required for further processing or movement.

As amended, R.1984 d.133 effective April 16, 1984.
See: 15 N.J.R. 1059(b), 16 N.J.R. 882(a).

"SIU" clarified.
Amended by R.1989 d.282, effective June 5, 1989.
See: 21 N.J.R. 373(a), 21 N.J.R. 1530(a).

Recodified from N.J.A.C. 7:14-4.4. Deleted definitions for "Average daily flow", "grab sample", "industrial process wastewater", "industrial process wastewater sludge", "inhibitory pollutant", "SIU pretreatment works", "liquid phase", "monthly moving average", "Significant Industrial User", "solid phase", "toxic pollutant" and "user". Added definitions for "BOD", "COD", "domestic pollutant", "domestic wastewater sludge", "effluent", "permit-by-rule discharger", "permitted flow", "process wastewater", "process wastewater sludge", "significant indirect user", "SIU pretreatment works", "sludge quality criteria" and "ultimate management". Amended "domestic wastewater" and "industrial treatment works".

7:14-4.4 Analytical procedures

(a) Analyses shall be performed on the total sludge sample and shall be expressed on a bulk dry weight basis (mg/kg) except as specifically provided in the sludge reports in Appendix B.

(b) Analyses shall be conducted in accordance with methods for sludge analyses promulgated under N.J.A.C. 7:18.

(c) Where a laboratory method for sludge analysis is not provided for in N.J.A.C. 7:18 for a parameter required by N.J.A.C. 7:14-4.7, the analysis shall be conducted in accordance with the appropriate laboratory method specified in Appendix A which is incorporated into this subchapter.

(d) Where a laboratory method for sludge analyses is not provided for in N.J.A.C. 7:18 or Appendix A, the analysis shall be conducted in accordance with the test procedures or recommendations as established in the following documents, including amendments and revisions (laboratories may only use alternative test procedures upon specific written permission from the Bureau of Pretreatment and Residuals, Division of Water Resources, CN-029, Trenton, New Jersey 08625):

1. "Test Methods For Evaluating Solid Waste", SW-846, USEPA, Office of Solid Waste and Emergency Response, Washington, D.C., 1986b.

2. "POTW Sludge Sampling and Analysis Guidance Document", USEPA, Office of Water Enforcement and Permits, Washington, D.C., June 1988.

(e) Analyses conducted for the purpose of determining the formal waste classification of the sludge shall be performed in accordance with the requirements specified in N.J.A.C. 7:26-8 and/or pursuant to requirements and guidance of the Bureau of Hazardous Waste Regulation and Classification, Division of Hazardous Waste Management, CN-028, Trenton, New Jersey 08625.

(f) All laboratories performing analyses under these rules shall perform and maintain all quality control data and records as required by N.J.A.C. 7:18. Laboratories shall follow the entire test procedure for sludge analyses specified in (b), (c) and (d) above to completion without any modification. All quality control procedures as cited in the referenced analytical techniques shall be performed and documented. Said documentation shall be provided by the certified laboratory performing the sludge analyses to the authority requesting the analyses. All domestic and industrial treatment works are required to maintain on file the entire analysis and quality control data package for a period of five years from the date of the sludge sample. All laboratories shall follow the general reporting format as specified under the "NJDEP Contract Data Report", which can be obtained from the Office of Quality Assurance, Division of Environmental Quality, CN-027, Trenton, New Jersey 08625.

(g) All sludge analyses required for the completion of form T-VWX-008, form T-VWX-009 and form T-VWX-010B set forth in Appendix B shall be performed by laboratories certified by the Department pursuant to N.J.A.C. 7:18. The laboratories shall use the analytical procedures specified in (b), (c) and (d) above.

(h) Analyses required for completion of form T-VWX-007 and form T-VWX-010A set forth in Appendix B

need not be performed by a certified laboratory, except as specifically provided by (i) below. Analytical procedures as specified in (b), (c) and (d) above shall be used.

(i) The analyses required for completion of items B(6), B(7) and D on form T-VWX-010A shall be performed by laboratories certified by the Department, pursuant to N.J.A.C. 7:18. The laboratories shall use the analytical procedures as specified in (b), (c) and (d) above.

Repeal and New Rule, R.1989 d.282, effective June 5, 1989.
See: 21 N.J.R. 373(a), 21 N.J.R. 1530(a).

This rule was recodified from N.J.A.C. 7:14-4.7 and was originally entitled "Testing procedures"; the text of that rule was repealed and replaced with all new language as part of this rulemaking.

7:14-4.5 Reporting categories

(a) For the purposes of determining the frequency of sampling and analysis for submission of all required sludge reports and for determining proper sampling procedures, domestic treatment works shall be divided into categories on the basis of permitted daily flow as follows:

1. Category 1: domestic treatment works with a permitted daily flow of 0.099 MGD or less.
2. Category 2: domestic treatment works with a permitted daily flow from 0.1 to 0.999 MGD.
3. Category 3: domestic treatment works with a permitted daily flow from 1.0 to 4.999 MGD. Category 3 shall additionally include any category 1 or 2 domestic treatment works which has obtained the Department's written determination of residual quality suitability where the determination of residual quality suitability is required in order to utilize agricultural land application or distribution and marketing of a sludge derived product as a fertilizer or soil amendment, either directly or indirectly.
4. Category 4: domestic treatment works with a permitted daily flow equal to or greater than 5.0 MGD.
5. Category 5: domestic treatment works with a flow to which more than 10 percent of the permitted daily flow or the permitted daily mass loading of BOD, COD or Suspended Solids is contributed by SIUs.

(b) All industrial treatment works shall be included in the industrial treatment works category for reporting frequency except as provided by N.J.A.C. 7:14-4.11.

(c) All permit-by-rule dischargers which are regulated pursuant to N.J.A.C. 7:14A-13.5 shall be included in the permit-by-rule category, except as provided by N.J.A.C. 7:14-4.11.

Repeal and New Rule, R.1989 d.282, effective June 5, 1989.
See: 21 N.J.R. 373(a), 21 N.J.R. 1530(a).

A rule concerning preparation and submission of sludge reports was formerly at this cite.

7:14-4.6 Sampling procedures

(a) All sludge samples shall be representative of the chemical and physical characteristics of the sludge removed from the treatment unit process immediately preceding ultimate management. For example, if a treatment works discharges dewatered filter cake for land application, then sampling activity must focus on the output sludge stream from the dewatering device (that is, vacuum filter, belt filter press, etc.).

(b) Sampling locations shall be as follows unless an alternative sampling location is approved in writing by the Department:

1. Sampling points for liquid sludge samples shall be at taps on the discharge side of sludge pumps.
2. For treatment works utilizing drying beds, one-quarter cup sludge samples should be taken at five foot intervals across the bed surface. Neither the weathered surface nor sand should be included in the sample.
3. For treatment works producing a dewatered sludge cake, samples of the sludge should be taken from the point of sludge cake discharge.
4. For treatment works with heat treated sludge, samples shall be taken from taps on the discharge side of positive displacement pumps after decanting from the heat treatment unit.
5. Where a treatment works generates several different types of sludges (for example, primary, secondary or advanced wastewater treatment sludges) each of which is removed separately for ultimate management, separate composite samples shall be analyzed and reported pursuant to N.J.A.C. 7:14-4.7. All reports shall be clearly marked as to the origin of the sludge sample.

(c) Samples shall be prepared in accordance with the following:

1. The sample collection, handling and preservation techniques set out in Table 1 below shall be followed for all sludge analyses required to be performed pursuant to this subchapter.

TABLE 1. CONTAINERS, PRESERVATION, HOLDING TIMES, AND MINIMUM SAMPLE VOLUMES

<u>Parameter</u>	<u>Container</u>	<u>Preservative</u>	<u>Maximum Holding Time</u>	<u>Minimum Sample Volume (a)</u>
<u>Metals</u>				
Chromium VI	P, G	Cool, 4°C	48 hours	300 mL
Mercury	P, G	HNO ₃ to pH<2	28 days	500 mL
Metals except above	P, G	HNO ₃ to pH<2	6 months	1000 mL

<u>Parameter</u>	<u>Container</u>	<u>Preservative</u>	<u>Maximum Holding Time</u>	<u>Minimum Sample Volume</u> ^(a)
Organic Compounds				
Extractables (including phthalates, nitrosamines organochlorine pesticides, PCBs, nitroaromatics, isophorone, polynuclear aromatic hydrocarbons, haloethers, chlorinated hydrocarbons and TCDD)	G, teflon-lined cap	Cool, 4°C 0.008% Na ₂ S ₂ O ₃	7 days (until extraction) 30 days (after extraction)	1000 mL
Extractable (phenols)	G, teflon-lined cap	Cool, 4°C H ₂ SO ₄ to pH<2 0.008% Na ₂ S ₂ O ₃	7 days (until extraction) 30 days (after extraction)	1000 mL
Purgeables (Halocarbons and Aromatics)	G, teflon-lined septum	Cool 4°C 0.008% Na ₂ S ₂ O ₃ HCL to pH<2	14 days	50 mL
Purgeables (Acrolein and Acrylonitrile)	G, teflon-lined septum	Cool 4°C 0.008% Na ₂ S ₂ O ₃	14 days	50 mL
Pesticides	G, teflon-lined septum	Cool 4°C 0.008% Na ₂ S ₂ O ₃	7 days (until extraction) 30 days (after extraction)	1000 mL

(a) Varies with analytical method. Consult 40 CFR Part 136. P = Plastic G = Glass

NOTE: 0.008% Na₂S₂O₃ is only required when Cl₂ residual is known to be present.

2. Samples requiring preservation shall be preserved at the time of collection. A certified laboratory or a laboratory that has interim approval or certification shall accept only samples which are properly labeled and for which there is reasonable assurance that they have been collected, preserved, processed, stored and transported in a manner which assures the stability of the sample with respect to the requested tests or analyses. If the stability of the sample has not been assured, the laboratory report shall clearly state that the result may be invalid due to an unsatisfactory sample. If a preservative cannot be utilized at the time of collection (that is, incompatible preservation requirements), it is acceptable to initially preserve by icing the entire sample during compositing and immediately ship it to the laboratory at the end of the sampling period. Upon receipt in the laboratory, the sample shall be properly preserved.

3. All samples shall be chilled at four degrees Celsius during compositing and holding.

4. For dewatered or dried sludge samples preservation shall consist of chilling to four degrees Celsius. Use of a chemical preservative is generally not useful due to failure of the preservative to penetrate the sludge matrix.

5. Samples for reporting on form T-VWX-007 shall be obtained in accordance with the following:

i. Domestic treatment works in category 1 or 2 shall report the average of the values obtained from analyses performed on four samples of equal volume of sludge generated by said treatment works spaced one week apart during the reporting period; and

ii. Domestic treatment works in category 3, 4 or 5, shall report the average of the values obtained from analyses performed on equal volume samples of sludge generated by said treatment works collected every working day during the reporting period.

6. Composite samples for reporting on form T-VWX-008 and form T-VWX-009 shall be obtained in accordance with the following:

i. Domestic treatment works in category 1 or 2 shall form a composite using five samples of equal volumes collected one day apart during the reporting period; and

ii. Domestic treatment works in category 3, 4 or 5 shall form a composite using seven samples of equal volumes collected one day apart during the reporting period. Each daily sample shall consist of six or more samples collected over the 24 hour period.

7. Industrial treatment works shall form a composite sample for form T-VWX-010A and form T-VWX-010B using five samples of equal volumes collected one day apart during the reporting period.

8. Composite samples for formal waste classifications and priority pollutant scans for domestic and industrial treatment works shall be obtained by forming a composite using five samples of equal volumes collected one day apart during the reporting period.

9. As either sludge detention time or mixing increases within a treatment plant, the sampling frequencies required by this section may be reduced, upon written approval from the Department, since certain treatment works' processes (for example, digestion, storage/blending facilities, etc.) will effectively composite sludge to a greater degree.

(d) Procedures for sampling or compositing may be modified upon written approval of the Department based upon site specific operational requirements. Requests for reductions or modifications shall be sent to the Bureau of Pre-treatment and Residuals, Division of Water Resources, CN-029, Trenton, New Jersey 08625. Existing sampling points or procedures may be retained by an industrial or domestic treatment works which submits a written request

to the Department for retention before August 1, 1989. Said alternative procedures may be utilized until and unless otherwise directed by the Department.

Repeal and New Rule, R.1989 d.282, effective June 5, 1989.
See: 21 N.J.R. 373(a), 21 N.J.R. 1530(a).

The rule formerly at this cite was entitled "Action of the Commissioner".

7:14-4.7 Reporting requirements

(a) Sludge reports required by these rules shall be submitted on the computer forms reproduced in Appendix B which is incorporated into this subchapter. These computer forms may be obtained by contacting the Bureau of Pretreatment and Residuals, Division of Water Resources, CN-029, Trenton, New Jersey 08625. Each domestic and industrial treatment works may duplicate blank copies of said forms and shall maintain necessary supplies.

(b) Analyses for the priority pollutants which are listed in Appendix C and incorporated into this subchapter, required under (d) and (e) below, may be submitted on forms provided by a New Jersey certified laboratory.

(c) All reports shall be addressed to the Bureau of Information Systems, Management Services Element, Division of Water Resources, CN-029, Trenton, New Jersey 08625.

(d) The following are the reporting requirements for domestic treatment works:

1. All owners or operators of a domestic treatment works shall prepare a Domestic Wastewater Sludge Report (T-VWX-007) for every calendar month. The report shall be submitted to the Department on or before the first day of the third month following the last day of the reporting period. Reporting periods for form T-VWX-007 shall begin on the first day of each month and end on the last day of each month.

2. The owner or operator of a domestic treatment works shall prepare a Metals and Selected Chemical Parameters Report (T-VWX-008) and a Toxic Organic Compounds Report (T-VWX-009) for each reporting period. The reports shall be submitted to the Department on or before the first day of the third month following the last day of the reporting period. The reporting periods for each category shall be as follows:

- i. The reporting period for category 1 shall be the month of January;
- ii. Category 2 reporting periods shall be the months of January and July;
- iii. Category 3 reporting periods shall be the months of January, April, July and October; and
- iv. Categories 4 and 5 shall prepare a form T-VWX-008 and a form T-VWX-009 report for each calendar month.

3. The owner or operator of a domestic treatment works shall submit a full priority pollutant scan on the domestic wastewater sludge produced at the domestic treatment works for the priority pollutants listed in Appendix C. In addition, the largest 15 purgeable volatile organic peaks, 10 acid extractable peaks and 15 base/neutral extractable peaks shall be identified and reported. The report shall be submitted to the Department on or before the first day of the third month following the last day of the reporting period. The reporting periods for each category shall be as follows:

- i. The reporting period for categories 1 and 2 shall be the month of February during years ending in five or zero (that is, 1990, 1995, 2000, etc.);
- ii. The reporting period for categories 3, 4 and 5 shall be the month of August, annually;
- iii. All POTWs with an industrial pretreatment program approved by the Department in accordance with 40 CFR 403 shall perform their priority pollutant scans for sludge during the same period when influent priority pollutant scans, required by their NJPDES permit, are performed; and
- iv. The Department may, after the receipt of a priority pollutant scan, require a domestic treatment works to increase the schedule of reporting for any or all constituents which are detected on a priority pollutant scan.

4. The Department may require a formal waste classification to be made, pursuant to the requirements of N.J.A.C. 7:14-4.4(e), on a case-by-case basis. The Department may specify a frequency for performing the required determination based on available sludge quality data or knowledge of industrial discharges into the system.

5. A domestic treatment works shall comply with the sludge quality criteria applicable to the ultimate management alternative utilized by the domestic treatment works as specified in:

- i. The Statewide Sludge Management Plan;
- ii. Criteria established under 33 U.S.C.A. Section 1251 et seq.;
- iii. 40 CFR 257; or
- iv. NJPDES permit conditions pursuant to N.J.A.C. 7:14A.

6. A domestic treatment works shall report any non-compliance with the sludge quality criteria to the Department. The noncompliance with the sludge quality criteria shall be orally reported within 24 hours to the Bureau of Pretreatment and Residuals at (609) 633-3823 and to the ultimate sludge management site. A written submission shall be made within five days thereafter to: Chief, Bureau of Pretreatment and Residuals, Division of Water Resources, CN-029, Trenton, New Jersey 08625 and shall include the following information:

- i. Dates of occurrence;
- ii. A description of the noncompliance with the sludge quality criteria;
- iii. The cause of the noncompliance; and
- iv. Steps being taken to reduce, eliminate and prevent reoccurrence of the noncompliance.

(e) The following are the reporting requirements for the industrial treatment works category:

1. The owner or operator of an industrial treatment works that produces process wastewater sludge shall prepare an Industrial Process Wastewater Sludge Report (T-VWX-010A) for every calendar month. The report shall be submitted to the Department on or before the first day of the third month following the last day of the reporting period;

2. The owner or operator of an industrial treatment works shall prepare an Industrial Process Wastewater Sludge Report (T-VWX-010B) for every calendar month. The report shall include an analysis of the sludge for all those toxic pollutants listed in N.J.A.C. 7:14A, Appendix B, Table II, III, IV, V and VI that are currently manufactured, processed, formed, repackaged, handled, used, disposed or stored in the facility served by the industrial treatment works and as required to be reported on the Discharge Monitoring Report pursuant to N.J.A.C. 7:14A-2.5. The report shall be submitted to the Department on or before the first day of the third month following the last day of the reporting period;

3. The owner or operator of an industrial treatment works shall submit a full priority pollutant scan on each process wastewater sludge produced for the priority pollutants listed in Appendix C. In addition, the largest 15 purgeable volatile organic peaks, 10 acid extractable peaks and 15 base/neutral extractable peaks shall be identified and reported. The report shall be submitted to the Department on or before the first day of the third month following the last day of the reporting period;

4. The reporting period for submission of the full priority pollutant scan for all industrial treatment works shall be annually in the month of November. If the nature of the process wastewater or sludge produced by an industrial treatment works should change at any time due to an increase or change in process wastewater contributions, a change in treatment processes at the industrial treatment works or a change in its process, handling, manufacturing, packaging, storage or disposal practices, a new priority pollutant scan shall be submitted within 90 days; and

5. The Department may require an industrial treatment works to increase the schedule of reporting for any or all constituents which are detected on a priority pollutant scan.

6. The Department may require a formal waste classification to be made, pursuant to the requirements of N.J.A.C. 7:14-4.4(e), on a case-by-case basis. The Department may specify a frequency for performing the required determination based on available sludge quality data or knowledge of process wastewater contributions.

7. Any noncompliance with the sludge quality criteria shall be immediately reported pursuant to the procedure outlined in (d)6 above.

(f) The permit-by-rule category shall be required to sample, perform analyses and maintain records on file for a period of five years in accordance with the reporting requirements for industrial treatment works in (e) above.

Repeal and New Rule, R.1989 d.282, effective June 5, 1989.
See: 21 N.J.R. 373(a), 21 N.J.R. 1530(a).

The rule formerly at this cite was entitled "Testing procedures".

7:14-4.8 Access

The owner or operator of a domestic or industrial treatment works shall provide access to the treatment works' premises and related records to representatives of the Department upon presentation of identification or credentials during normal working hours. The Department may take samples of sludge to verify the reported analytical data and to determine if the treatment works is in compliance with the reporting requirements of this subchapter.

Amended by R.1989 d.282, effective June 5, 1989.
See: 21 N.J.R. 373(a), 21 N.J.R. 1530(a).

Reference to SIU pretreatment, deleted.

7:14-4.9 Non-compliance

A failure to submit the required sludge reports in the manner prescribed by this subchapter or any willful falsification of information contained in these reports shall constitute a violation of the New Jersey Water Pollution Control Act, N.J.S.A. 58:10A-1 et seq. and shall be subject to the penalties contained in N.J.A.C. 7:14-8 and 7:19-6.14.

Amended by R.1989 d.282, effective June 5, 1989.
See: 21 N.J.R. 373(a), 21 N.J.R. 1530(a).

N.J.A.C. cite added.

7:14-4.10 Implementation

(a) All domestic and industrial treatment works and permit-by-rule dischargers shall commence reporting under these rules on June 1, 1989.

(b) All new domestic and industrial treatment works shall submit their first report within 90 days after their start of operations. Thereafter, they shall follow the reporting schedule prescribed by N.J.A.C. 7:14-4.7. All new permit-by-rule dischargers shall commence reporting under these rules within 90 days after their start of operations.

Amended by R.1989 d.282, effective June 5, 1989.
See: 21 N.J.R. 373(a), 21 N.J.R. 1530(a).

All new text added, old text deleted.

7:14-4.11 Exemptions and reductions in reporting requirements

(a) The following exemptions and reductions in reporting requirements are applicable to domestic treatment works:

1. There shall be no exemptions or reductions for domestic treatment works in the reporting frequency or requirements for completing form T-VWX-007, form T-VWX-008 or form T-VWX-009.

2. The Department may reduce the requirement to perform an annual priority pollutant scan to years ending in five or zero for domestic treatment works in categories 3, 4 or 5, based on current sludge quality, present or anticipated sludge management practices or knowledge of industrial discharges into the system. The request for a reduction shall be submitted in writing. The domestic treatment works may request a reduction at any time after submission of the first required report. Any domestic treatment works granted a reduction shall comply with the following:

i. The domestic treatment works shall submit to the Department, on an annual basis, an affidavit affirming that there have been no changes to the nature of the service area in a manner such that the analysis of the sludge generated by the domestic treatment works may also change. The affidavit shall be submitted by May 1, of each calendar year; and

ii. If the nature of the sludge produced by a domestic treatment works on a reduced reporting schedule should change at any time due to an increase or change in process wastewater contributions or a change in treatment processes at the domestic treatment works, the owner or operator shall, within 30 days, notify the Department of the nature of the change. Based upon this information, the Department may require additional analyses to be performed and require that the domestic treatment works return to the reporting schedule required under N.J.A.C. 7:14-4.7.

(b) The following exemptions and reductions in reporting requirements are applicable to industrial treatment works and permit-by-rule treatment works:

1. The following industrial and permit-by-rule treatment works shall be exempt from all reporting requirements:

i. Noncontact cooling water treatment works;

ii. Treatment works for the discharge of untreated storm water; and

iii. Treatment works which are not regulated pursuant to N.J.A.C. 7:14A.

2. The Department may reduce the reporting requirements for submission of the Industrial Process Wastewater Sludge Reports (form T-VWX-010A and form T-VWX-010B) for the following treatment works:

i. Treatment works regulated by permits under N.J.A.C. 7:14A which are not required to remove contaminants and are only required to submit monitoring reports;

ii. If an industrial treatment works has a process wastewater permitted flow of 10,000 gallons per day or less, the Department may reduce the frequency of reporting after submission of the first Industrial Process Wastewater Sludge Reports (form T-VWX-010A and form T-VWX-010B);

iii. If an industrial treatment works produces a process wastewater sludge which is recycled, the industrial treatment works may apply for a change in the frequency of reporting after submission of the first required Industrial Process Wastewater Sludge Reports (form T-VWX-010A and form T-VWX-010B); and

iv. Where an industrial treatment works can demonstrate to the Department's satisfaction, based on the criteria in (b)5 below, that removal schedules or historical sludge quality justify a reduction, the Department may reduce the reporting frequency at any time after submission of the first required Industrial Process Wastewater Sludge Reports (form T-VWX-010A and form T-VWX-010B).

3. The following treatment works shall be exempt from the reporting requirements for submission of a priority pollutant scan:

i. Industrial treatment works which treat only process wastewater contributed from the processing of food for human consumption; and

ii. Industrial treatment works which treat only process wastewater contributed from the treatment of surface water or groundwater for human consumption.

4. The industrial treatment works identified in (b)2 above may apply to the Department for a reduction in the frequency of reporting for the priority pollutant scan.

5. The Department's determination of reductions or exemptions in reporting requirements for industrial treatment works will be based on the following criteria:

i. All requests for a reduction in the reporting frequency shall be accompanied by a complete analysis for those substances required to be reported under these rules. The request for a reduction shall also be accompanied by a flow diagram which documents each and every manufacturing or production campaign, a detailed description of the individual treatment processes and a list of those substances for which the reduction is requested;

ii. In considering requests for reduced reporting, the Department will consider the quantity and quality of the sludge produced, removal frequency, storage provisions, ultimate management mode, the quantities and toxicities of the substances for which the reduction is requested and the likelihood for soil, water or air pollution associated with management of the sludge;

iii. The Department will review all requests and may grant a reduction, or may require additional analytical testing for any or all of the pollutants required to be reported in N.J.A.C. 7:14-4.7. The Department may also require that the applicant for a reduction demonstrate that the use of best management practices justifies the request;

iv. Any industrial treatment works granted a reduction shall submit to the Department, on an annual basis, an affidavit affirming that there have been no changes to the nature of the process wastewater, in a manner such that the sludge generated by the industrial treatment works may also change. The affidavit shall be submitted by May 1, of each calendar year; and

v. If the nature of the process wastewater or sludge produced by an industrial treatment works on a reduced reporting schedule should change at any time due to an increase or change in process wastewater contributions, a change in treatment processes at the industrial treatment works or a change in its process, handling, manufacturing, packaging, storage or disposal practices, the owner or operator shall, within 30 days, notify the Department of the nature of the change. Based upon this information, the Department may require analyses to be performed and require that the industrial treatment works return to the reporting schedule required by N.J.A.C. 7:14-4.7.

(c) All treatment works shall continue to submit reports as required in N.J.A.C. 7:14-4.7 until written Department approval has been provided which exempts or reduces reporting requirements.

Repeal and New Rule, R.1989 d.282, effective June 5, 1989.
See: 21 N.J.R. 373(a), 21 N.J.R. 1530(a).

The rule formerly at this cite was entitled "Reports to be published by the Department".

7:14-4.12 Severability

If any provision of this subchapter or the application thereof to any person or circumstances is held invalid, such invalidity shall not affect other provisions or applications, and to this end, the provisions of the subchapter are declared to be severable.

7:14-4.13 (Reserved)

Repealed by R.1989 d.282, effective June 5, 1989.
See: 21 N.J.R. 373(a), 21 N.J.R. 1530(a).

Former rule entitled "Reporting categories for domestic treatment works".

7:14-4.14 (Reserved)

Repealed by R.1989 d.282, effective June 5, 1989.
See: 21 N.J.R. 373(a), 21 N.J.R. 1530(a).
Former rule entitled "Sludge Report".

7:14-4.15 (Reserved)

Repealed by R.1989 d.282, effective June 5, 1989.

See: 21 N.J.R. 373(a), 21 N.J.R. 1530(a).

Rule formerly entitled "Heavy Metals and Selected Chemical Parameters Report".

7:14-4.16 (Reserved)

Repealed by R.1989 d.282, effective June 5, 1989.
See: 21 N.J.R. 373(a), 21 N.J.R. 1530(a).

Rule formerly entitled "Toxic Organic Compounds Report".

7:14-4.17 (Reserved)

Repealed by R.1989 d.282, effective June 5, 1989.
See: 21 N.J.R. 373(a), 21 N.J.R. 1530(a).

Rule formerly entitled "Loss of reduction in reporting requirement".

7:14-4.18 (Reserved)

Repealed by R.1989 d.282, effective June 5, 1989.
See: 21 N.J.R. 373(a), 21 N.J.R. 1530(a).

Rule formerly entitled "Exemption from Heavy Metals and Toxic Organic Compounds reporting cycles".

7:14-4.19 (Reserved)

Repealed by R.1989 d.282, effective June 5, 1989.
See: 21 N.J.R. 373(a), 21 N.J.R. 1530(a).

Rule formerly entitled "Sampling procedure; Sludge Report".

7:14-4.20 (Reserved)

Repealed by R.1989 d.282, effective June 5, 1989.
See: 21 N.J.R. 373(a), 21 N.J.R. 1530(a).

Rule formerly entitled "Reporting requirements for industrial treatment works and SIU pretreatment works".

7:14-4.21 (Reserved)

Repealed by R.1989 d.282, effective June 5, 1989.
See: 21 N.J.R. 373(a), 21 N.J.R. 1530(a).

Rule formerly entitled "Sampling procedures; composite sample".

SUBCHAPTER 5. (RESERVED)

Subchapter Historical Note

Subchapter 5, formerly Statewide Management of Septage Disposal, was adopted pursuant to the authority of N.J.S.A. 58:10A-1 et seq., 58:11A-1 et seq., 13:1E-1 et seq., 13:1B-5 and 13:1D-1 et seq. and became effective June 23, 1980 as R.1980 d.277. See: 12 N.J.R. 111(c), 12 N.J.R. 462(a). Pursuant to Executive Order No. 66(1978), Subchapter 5 expired on June 23, 1985.

SUBCHAPTER 6. (RESERVED)

SUBCHAPTER 7. (RESERVED)

Subchapter Historical Note

Subchapter 7, formerly Ocean Dumping Alternative Development, was adopted pursuant to authority of N.J.S.A. 58:10A-1 et seq. and were filed and became effective on December 2, 1977, as R.1977 d.458.

See: 9 N.J.R. 460(b), 10 N.J.R. 10(b). Subchapter 7 was repealed by R.1989 d.282, effective June 5, 1989. See: 21 N.J.R. 373(a), 21 N.J.R. 1530(a).

SUBCHAPTER 8. CIVIL ADMINISTRATIVE PENALTIES AND REQUESTS FOR ADJUDICATORY HEARINGS

Subchapter Historical Note

Subchapter 8, Assessment of Civil Administrative Penalties, was originally filed and became effective March 15, 1979 as R.1979 d.111. See: 10 N.J.R. 533(a), 11 N.J.R. 173(c). The subchapter was readopted with amendments effective May 21, 1984 as R.1984 d.189. See: 16 N.J.R. 181(b), 16 N.J.R. 1225(a). Subchapter 8 was repealed and a new Subchapter 8, Civil Administrative Penalties and Requests for Adjudicatory Hearings (which raised the maximum civil administrative penalty from \$5,000 to \$50,000 for each violation and modified the Water Pollution Control Act), became effective August 1, 1988 as R.1988 d.380. See: 20 N.J.R. 455(a), 20 N.J.R. 1884(a).

7:14-8.1 Authority and purpose

(a) The purpose of this subchapter is to establish a civil administrative penalty policy governing the uniform assessment of civil administrative penalties. This subchapter shall also govern the Department's assessment of civil administrative penalties for violations of the Water Pollution Control Act, N.J.S.A. 58:10A-1 et seq., including violation on any rule or regulation, water quality standard, effluent limitation, administrative order or permit issued pursuant to the Water Pollution Control Act, violation of the rules governing laboratory certification and standards of performance, N.J.A.C. 7:18, and for violations of the Act Concerning Pretreatment of Industrial Wastewater, N.J.S.A. 58:11-64 et seq., the Water Supply and Wastewater Operators' Licensing Act, N.J.S.A. 58:11-64 et seq., and N.J.S.A. 58:10A-21 et seq. (also known as the New Jersey Underground Storage of Hazardous Substances Act). In addition, this subchapter shall govern the Department's administrative assessment of costs pursuant to N.J.S.A. 58:10A-10d(1)(c). This subchapter shall also govern the procedure for requesting an adjudicatory hearing on a notice of civil administrative penalty assessment or an administrative order.

(b) The Department may assess a civil administrative penalty of not more than \$50,000 for each violation of each provision of either the Water Pollution Control Act or the New Jersey Underground Storage of Hazardous Substances Act, or not more than \$100,000 for a violation of both statutes.

(c) Each day during which a violation as set forth in (b) above continues shall constitute an additional, separate and distinct violation.

(d) Neither the assessment of a civil administrative penalty nor the payment of any such civil administrative penalty shall affect the availability of any other enforcement provision provided for by N.J.S.A. 58:10A-10, or any other statute, in connection with the violation for which the assessment is levied.

(e) This subchapter, as amended effective January 19, 1999, shall apply to all violations which occur on or after January 19, 1999.

(f) This subchapter also establishes a civil administrative penalty policy governing the uniform assessment of civil administrative penalties by delegated local agencies as authorized pursuant to N.J.S.A. 58:10A-10.5. Nothing in this subchapter shall be construed to authorize a delegated local agency to take any action beyond the scope of its authority under N.J.S.A. 58:10A-10.5 through 10.10. Except as provided in this subsection, in connection with actions taken by a delegated local agency pursuant to N.J.S.A. 58:10A-10.5, all references in this subchapter to the Department shall be deemed to refer to the delegated local agency; the delegated local agency shall comply with all requirements which this subchapter imposes upon the Department, and may take all actions which this subchapter states that the Department may take, except that delegated local agencies shall not be subject to the requirement, at N.J.A.C. 7:14-8.4(a), that an adjudicatory hearing request be submitted to the Department's Office of Legal Affairs with a copy to the Department's enforcement bureau. A person requesting an adjudicatory hearing to contest an administrative order, notice of civil administrative penalty assessment, or notice of civil administrative cost assessment issued by a delegated local agency shall submit the request to the delegated local agency.

Amended by R.1989 d.282, effective June 5, 1989. See: 21 N.J.R. 373(a), 21 N.J.R. 1530(a).

Last sentence in (b) recodified as new (c), (c) recodified to (d) with no change in text.

Amended by R.1991 d.307, effective June 17, 1991.

See: 22 N.J.R. 2870(a), 23 N.J.R. 1926(a).

Deleted "violation of the rules governing laboratory certification and standard of performance, N.J.A.C. 7:18," in (a).

Amended by R.1991 d.378, effective August 5, 1991.

See: 23 N.J.R. 1089(a), 23 N.J.R. 2366(a).

In (a), added first sentence; added "or regulation"; added references to N.J.S.A. 58:11-49 et seq. and N.J.S.A. 58:10A-10d(1)(c).

Added (e).

Amended by R.1995 d.162, effective March 20, 1995.

See: 26 N.J.R. 4912(a), 27 N.J.R. 1265(a).

Amended by R.1997 d.106, effective May 5, 1997.

See: 28 N.J.R. 720(a), 28 N.J.R. 2779(a), 28 N.J.R. 3040(a), 28 N.J.R. 3494(a), 28 N.J.R. 4697(a), 29 N.J.R. 1691(c).

In (e), amended effective dates; and added (f).

Amended by R.1999 d.32, effective January 19, 1999.

See: 30 N.J.R. 1356(a), 31 N.J.R. 157(a).

In (e), substituted "January 19, 1999" for "May 5, 1997" throughout; and rewrote (f).

Case Notes

Discharge monitoring ordered as part of penalty found proper exercise of Commissioner's authority. Dept. of Environmental Protection v. Kearney Industries, 3 N.J.A.R. 339 (1981).

7:14-8.2 Definitions

As used in this subchapter, the following words and terms shall, in addition to those provided in N.J.A.C. 7:14A-1.9, have the following meanings unless the context clearly indicates otherwise.

“Any rules issued pursuant to the Water Pollution Control Act” means, but is not limited to, the following rules:

- Industrial Survey Project, N.J.A.C. 7:1F;
- Freshwater Wetlands, N.J.A.C. 7:7A;
- Stormwater Management, N.J.A.C. 7:8;
- Water Pollution Control, N.J.A.C. 7:9;
- Standards for Individual Subsurface Sewage Disposal Systems, N.J.A.C. 7:9A;
- Safe Drinking Water Act, N.J.A.C. 7:10;
- Flood Hazard Area Control, N.J.A.C. 7:13;
- Water Pollution Control Act, N.J.A.C. 7:14;

The New Jersey Water Pollution Control Act, N.J.A.C. 7:14A;

Statewide Water Quality Management Planning, N.J.A.C. 7:15;

Regulations Governing Laboratory Certification and Standards of Performance, N.J.A.C. 7:18; and

Sewage Infrastructure Improvement Act Grants, N.J.A.C. 7:22A.

“Bypass” means the anticipated or unanticipated intentional diversion of waste streams from any portion of a treatment works.

“Delegated local agency” means a local agency with an industrial pretreatment program approved by the Department.

“Discharge” means an intentional or unintentional action or omission resulting in the releasing, spilling, leaking, pumping, pouring, emitting, emptying, or dumping of a pollutant into the waters of this State, onto land or into wells from which it might flow or drain into such waters, or into waters or onto lands outside the jurisdiction of the State which pollutant enters the waters of this State, and shall include the release of any pollutant into a municipal treatment works. A leak into a secondary containment system which does not involve a release into the waters or lands of this State is not a “discharge” for purposes of applying the rules under this chapter to violations of the Underground Storage of Hazardous Substances Act, N.J.S.A. 58:11-49 et seq., and the rules promulgated pursuant thereto, N.J.A.C. 7:14B.

“Discharge Monitoring Report” or “DMR” means the Environmental Protection Agency’s current uniform national form, including any subsequent additions, revisions, modifications and replacements, for the reporting of self-monitoring results by permittees for discharge point sources.

“Effluent limitation” means any restriction on quantities, quality, rates and concentration of chemical, physical, thermal, biological, and other constituents of pollutants established by permit, or imposed as an interim enforcement effluent limitation pursuant to an administrative order, including an administrative consent order.

“Federal Act” means the “Federal Water Pollution Control Act Amendments of 1972” (Public Law 92-500; 33 U.S.C. § 1251 et seq.) including any subsequent amendments.

“Hazardous pollutant” means:

1. Any toxic pollutant;
2. Any hazardous substance as defined pursuant to section 3 of P.L. 1976, c.141 (N.J.S.A. 58:10-23.11b);
3. Any substance regulated as a pesticide under the Federal Insecticide, Fungicide and Rodenticide Act, Pub.L. 92-516 (7 U.S.C. § 136 et seq.);
4. Any substance the use or manufacture of which is prohibited under the Federal Toxic Substances Control Act, Pub.L. 94-469 (15 U.S.C. § 2601 et seq.);
5. Any substance identified as a known carcinogen by the International Agency for Research on Cancer; or
6. Any hazardous waste as designated pursuant to section 3 of P.L. 1981, c.279 (N.J.S.A. 13:1E-51) or the “Resource Conservation and Recovery Act,” Pub. L.94-580 (42 U.S.C. § 6901 et seq.).

“Lawful entry” means an entry by the Commissioner into any building, place, or premise pursuant to N.J.S.A. 13:1D, 58:10A and as otherwise provided by law, ordinance, regulation, order, permit or agreement.

“LC50” means the median lethal concentration of a toxic substance, including an effluent, expressed as a statistical estimate of the concentration that is lethal to 50 percent of the test organisms under specified test conditions, based on the results of an acute toxicity test. For purposes of this subchapter, it includes an EC50, the median effective concentration, based on daphnid immobilization.

“Local agency” means a political subdivision of the State, or an agency or instrumentality thereof, that owns or operates a municipal treatment works.

“Major facility” means any facility or activity classified as such by the Administrator of the United States Environmental Protection Agency, or his or her representative, in conjunction with the Department, and includes industrial facilities and municipal treatment works.

“Monitoring report form” means the standard Department form, including any subsequent additions, revisions or modifications, for the reporting of data pursuant to certain DGW permits.

“NOEC” or “no observable effect concentration” means the highest concentration of a toxic substance, including an effluent, that has no adverse effect on survival, growth, or reproduction of test organisms based upon the results of chronic toxicity testing.

“No Measurable Acute Toxicity” or “NMAT” means a type of water quality based acute whole effluent toxicity limit imposed in accordance with N.J.A.C. 7:9-4.6(c)5i(2), which requires that no mortality occur in any acute toxicity test concentration, including 100 percent effluent, above normal background mortality levels for the test organism population. The normal background mortality level is the acceptable level of control mortality for a valid test specific in N.J.A.C. 7:18-6.6(v).

“Permit” means an authorization, license, or equivalent control document issued by the Department to implement the requirements of this chapter even where any or all of the conditions of the permit have been stayed. A permittee is not subject to enforcement for an exceedance of any permit conditions which have been stayed. Permit does not include any permit which requires EPA review pursuant to 40 CFR Part 123.75, such as a “draft permit” or a “proposed permit.” Permit includes a letter of agreement entered into between a delegated local agency and a user of its municipal treatment works, setting effluent limitations and other conditions on the user of the agency’s municipal treatment works.

“Person” means any entity or natural person, including without limitation any of the following: individual, corporation, company, partnership, firm, association, owner or operator of a treatment works, political subdivision of this State and any state or interstate agency. “Person” shall also include any responsible corporate official for the purpose of enforcement action under section 10 of the State Act.

“Pollutant” means any dredged spoil, solid waste, incinerator residue, sewage, garbage, refuse, oil, grease, sewage sludge, munitions, chemical wastes, biological materials, radioactive substance, thermal waste, wrecked or discarded equipment, rock, sand, cellar dirt, and industrial, municipal or agricultural waste or other residue discharged into the waters of the State.

“Schedule of compliance” or “compliance schedule” means a schedule of remedial measures including an enforceable sequence of actions or operations leading to compliance with water quality standards, an effluent limitation or other limitation, prohibition or standard.

“Serious violation” means an exceedance, at a discharge point source, of an effluent limitation, except color, set forth in a permit, administrative order, or administrative consent agreement, including interim enforcement limits, as follows:

1. For effluent limitations for pollutants that are measured by concentration or mass, except for whole effluent toxicity;
 - i. Violations of an effluent limitation that is expressed as a monthly average:
 - (1) By 20 percent or more for a hazardous pollutant; and
 - (2) By 40 percent or more for a nonhazardous pollutant;
 - ii. Violations of an effluent limitation that is expressed as a daily maximum or daily minimum without a monthly average:
 - (1) By 20 percent or more of the average of all of the daily maximum or minimum values for a hazardous pollutant; and
 - (2) By 40 percent or more of the average of all of the daily maximum or minimum values for a nonhazardous pollutant; and
2. For effluent limitations for whole effluent toxicity as follows:
 - i. For any violation of an LC50 or a NOEC limit when, upon subtracting the toxicity test result from the whole effluent toxicity limit, the difference is as follows:

Whole Effluent Toxicity Limit (% Effluent)	Difference (% Effluent)
greater than or equal to 80 and less than or equal to 100	greater than or equal to 20

Whole Effluent Toxicity Limit (% Effluent)	Difference (% Effluent)
greater than or equal to 50 and less than 80	greater than or equal to 15
greater than 10 and less than 50	greater than or equal to 10
less than or equal to 10	greater than or equal to 9

ii. Any violation of a No Measurable Acute Toxicity (NMAT) limit with greater than or equal to 50 percent mortality in any test concentration, including 100% effluent.

3. The greatest violation of a pH effluent range in any one calendar day which violation deviates from the midpoint of the range by at least 40 percent of the midpoint of the range excluding the excursions specifically excepted by a NJPDES permit with continuous pH monitoring.

For example: Assuming that a permittee’s effluent limitation range for pH is 6.0 to 9.0, the midpoint would be 7.5.

If five separate readings of pH during a given day were 4.3, 5.8, 6.5, 6.0 and 6.5, the reading of 4.3 would be a serious violation as follows:

$$7.5 \text{ (midpoint)} - 4.3 \text{ (greatest exceedance)} \times 100 = 42.6\% \\ 7.5 \text{ (midpoint)}$$

For example: Using the same information as above.

Forty percent of 7.5 is 3; therefore, if the greatest violation of a pH effluent range for any calendar day has a pH of 4.5 or less or a pH of 10.5 or greater, the violation would be a “serious violation.”

4. Notwithstanding the above, the Department may utilize, on a case-by-case basis, a more stringent factor of exceedance to determine a serious violation if the Department states the specific reasons therefore, which may include the potential for harm to human health or the environment.

“Significant noncomplier” or “SNC” means any person, except a local agency for an exceedance of an effluent limitation for flow, who commits any of the violations described below, unless the Department uses, on a case-by-case basis, a more stringent frequency or factor of exceedance to determine a significant noncomplier and the Department states the specific reasons therefor, which may include the potential for harm to human health or the environment. Violations which cause a person to become or remain an SNC include:

1. A serious violation for the same pollutant, at the same discharge point source, in any two months of any consecutive six month period;

2. Exceedance of an effluent limitation expressed as a monthly average, for the same pollutant, at the same discharge point source, by any amount in any four months of any consecutive six month period;

3. If there is not an effluent limitation for a particular pollutant expressed as a monthly average, exceedance of the monthly average of the daily maximums for the effluent limitation, for the same pollutant, at the same discharge point source, by any amount in any four months of any consecutive six month period;

4. Any exceedance of an effluent limitation for pH by any amount, excluding the excursions specifically excepted by a NJPDES permit with continuous pH monitoring, at the same discharge point source in any four months of any consecutive six month period; or

5. Failure to submit a completed discharge monitoring report in any two months of any consecutive six month period.

“Sludge Quality Assurance Report” or “SQAR” means the standard Department form, including any subsequent additions, revisions or modifications, for the reporting of sludge quality and quantity.

“State Act” means the Water Pollution Control Act, N.J.S.A. 58:10A-1 et seq.

“Toxic pollutant” means any pollutant identified pursuant to the Federal Act or any pollutant or combination of pollutants, including disease causing agents, which after discharge and upon exposure ingestion, inhalation, or assimilation into any organism, either directly or indirectly by ingestion through food chains, will, on the basis of information available to the Department, cause death, disease, behavioral abnormalities, cancer, genetic mutations, physiological malfunctions, including malfunctions in reproduction, or physical deformation, in such organisms or their offspring.

“Upset” means an exceptional incident in which there is unintentional and temporary noncompliance with an effluent limitation because of an event beyond the reasonable control of the permittee, including fire, riot, sabotage, or a flood, storm event, natural cause, or other act of God, or other similar circumstance, which is the cause of the violation. “Upset” also includes noncompliance consequent to the performance of maintenance operations for which a prior exception has been granted by the Department or a delegated local agency.

“Violator” means any person against whom the Department asserts a violation of the State Act or any rules issued pursuant to the Water Pollution Control Act.

“Whole effluent toxicity” means the aggregate toxic effect of an effluent measured directly by a toxicity test.

Amended by R.1991 d.307, effective June 17, 1991.

See: 22 N.J.R. 2870(a), 23 N.J.R. 1926(a).

Added “Any rules issued pursuant to the Water Pollution Control Act” means, but is not limited to, the following rules: . . .”.

Amended by R.1991 d.378, effective August 5, 1991.

See: 23 N.J.R. 1089(a), 23 N.J.R. 2366(a).

Added additional definitions including new definitions of “serious violations” and “significant noncompliers”; substantial revision of definition of “Hazardous pollutant”.

Amended by R.1992 d.145, effective April 6, 1992.

See: 23 N.J.R. 2238(a), 24 N.J.R. 1334(a).

Added “lawful entry”, “No Measurable Acute Toxicity” and revised “discharge”, “discharge monitoring report”, “serious violation” and “significant noncomplier”.

7:14-8.3 Procedures for assessment, payment and settlement of civil administrative penalties, and affirmative defenses

(a) To assess a civil administrative penalty under the Water Pollution Control Act, the New Jersey Underground Storage of Hazardous Substances Act, and the Water Supply and Wastewater Operators’ Licensing Act, the Department shall notify the violator by certified mail (return receipt requested) or by personal service. This Notice of Civil Administrative Penalty Assessment shall:

1. Identify the section of the statute, rule, water quality standards, effluent limitation, administrative order or permit violated;
2. Concisely state the facts which constitute the violation;
3. Specify the amount of the civil administrative penalty to be imposed; and
4. Advise the violator of the right to request an adjudicatory hearing pursuant to the procedures in N.J.A.C. 7:14-8.4.

(b) Payment of the civil administrative penalty is due upon receipt by the violator of the Department’s Final Order in a contested case, or when a Notice of Civil Administrative Penalty Assessment becomes a Final Order, as follows:

1. If no hearing is requested pursuant to N.J.A.C. 7:14-8.4, a Notice of Civil Administrative Penalty Assessment becomes a Final Order and is deemed received on the 21st day following receipt of the Notice of Civil Administrative Penalty Assessment by the violator;
2. If the Department denies the hearing request, a Notice of Civil Administrative Penalty Assessment becomes a Final Order upon receipt of notice of such denial; or
3. If the Department conducts an adjudicatory hearing, a Notice of Civil Administrative Penalty Assessment becomes a Final Order upon receipt by the violator of a Final Order in a contested case.

(c) In addition to the amount of the civil administrative penalty that is due and owing pursuant to (b) above, the violator shall also pay to the Department the interest on the

amount of the penalty, at the rate established by the New Jersey Supreme Court for interest rates on judgments as set forth in the Rules Governing the Courts of the State of New Jersey, as follows:

1. Interest shall accrue on the amount of the civil administrative penalty due and owing beginning on the 30th day after the date on which the penalty was due and owing and continuing until the civil administrative penalty is paid in full with interest if:

- i. A violator does not pay a civil administrative penalty imposed pursuant to a final order; or
- ii. A violator fails to make a civil administrative penalty payment pursuant to a payment schedule entered into with the Department; and

2. Interest, at the rate set forth in (c)1 above, shall accrue on the unpaid amount of a civil administrative penalty which is contested as a contested case under N.J.S.A. 52:14B-1 et seq., or appealed to the Appellate Division of the Superior Court, and upheld in full or in part, from the date the violator posted financial assurance under N.J.A.C. 7:14-8.4(a)9 or, in the case of a local agency, from the date the Department receives a local agency's hearing request, until the violator pays in full the civil administrative penalty and all interest accrued thereon.

(d) A civil administrative penalty imposed pursuant to a final order shall constitute a debt of the violator or discharger. The Department may docket the penalty with the clerk of the Superior Court. The penalty, as docketed, shall have the same standing as any judgment docketed pursuant to N.J.S.A. 2A:16-1, except that:

1. No lien shall attach to the property of a local agency; and
2. No lien shall attach to the real property of a violator if the violator posts a refundable bond or other security with the Commissioner pursuant to an appeal of a final order to the Appellate Division of the Superior Court.

(e) The Department may settle any civil administrative penalty assessed pursuant to this subchapter according to the factors identified in (f) below as follows:

1. In cases where the violator is a local agency which violates an administrative consent order, the Department may settle a civil administrative penalty as follows:
 - i. The Department may reduce the civil administrative penalty up to 50 percent, provided that the penalty as reduced is not less than any applicable minimum amount set forth in N.J.A.C. 7:14-8.5(a) or 8.9(e); and
 - ii. The Department may not reduce the amount of any component of a civil administrative penalty which represents the economic benefit gained by the violator from the violation;

2. Except as provided in (e)1 above, in the case of a violator who is a local agency which violates something other than an administrative consent order and then enters into an administrative consent order with the Department, which requires the local agency to take prescribed measures to comply with its permit, the Department shall have full discretion to settle the amount of the civil administrative penalty assessed or due for violations occurring during a period up to 24 months preceding the effective date of the administrative consent order, except that the Department shall neither:

- i. Reduce the amount of the civil administrative penalty less than the minimum amount, if applicable, prescribed in N.J.A.C. 7:14-8.5(a) or 8.9(e); nor
- ii. Reduce the amount of any component of a civil administrative penalty which represents the economic benefit gained by the violator from the violation.

3. In the case of all other violators:

- i. The Department may reduce the civil administrative penalty up to 50 percent, provided that the penalty as reduced is not less than any applicable minimum amount set forth in N.J.A.C. 7:14-8.5(a) or 8.9(e); and
- ii. The Department may not reduce the amount of any component of a civil administrative penalty which represents the economic benefit gained by the violator from the violation.

(f) In settling a civil administrative penalty, the Department may consider the following:

1. Mitigating or extenuating circumstances not considered in the notice of civil administrative penalty assessment;
2. The implementation by the violator of pollution prevention and/or abatement measures in addition to those minimally required by applicable statute or rule;
3. The implementation by the violator of measures to clean up, reverse or repair environmental damage previously caused by the violation;
4. The full payment by the violator of a specified part of the civil administrative penalty assessed if made within a time period established by the Department in an administrative order and/or a notice of civil administrative penalty assessment and provided that the violator waives the right to request an adjudicatory hearing on the civil administrative penalty; or
5. Any other terms or conditions acceptable to the Department.

(g) In its discretion the Department may enter into an agreement with a violator, in which the Department agrees to accept payment of a civil administrative penalty in installments over time. Such an agreement shall be in writing. The Department shall not enter into any such agreement if payment in full is due more than 90 days after execution of the agreement unless:

1. The violator is a local agency; or
2. The violator posts financial assurance with the Department upon execution of the agreement pursuant to one of the financial assurance mechanisms in Appendix D or in another form the Department individually approves in writing for this purpose. The financial assurance shall be in an amount that the Department reasonably determines will tend to ensure good faith compliance with the agreement. In determining the amount, the Department may consider any or all of the following factors:
 - i. The amount of the penalty;
 - ii. The amount and frequency of the installment payments due under the agreement;
 - iii. The duration of the agreement;
 - iv. Other remedies, aside from drawing upon the financial assurance, that the Department may exercise under the agreement if an installment payment is not timely made or if some other requirement of the agreement is not satisfied, and the extent to which such other remedies will tend to ensure compliance with the agreement;
 - v. The violator's history of compliance, including without limitation its history of compliance with other schedules for the payment of penalties assessed by the Department;
 - vi. Expenditures that the violator has made or has agreed to make for purposes of pollution control and/or pollution prevention; and
 - vii. Other specific circumstances of the violator relating to the tendency of the financial assurance to ensure compliance with the agreement or indicating the extent to which financial assurance is necessary to ensure compliance with the agreement.

(h) Any violator that is not a local agency which enters into an administrative consent order with the Department that includes a compliance schedule shall post financial assurance in the full amount of the cost of fully complying with all of the terms and conditions imposed by the Department pursuant to one of the financial assurance mechanisms in Appendix D, incorporated herein by reference, or in another form the Department individually approves in writing for this purpose.

(i) Except as provided in (i)1 below, a violator may be entitled to an affirmative defense to liability for a violation of an effluent limitation occurring as a result of an upset, an anticipated or unanticipated bypass, or a testing or laboratory error, only if, in the determination of the Department, the violator has satisfied the provisions of this section.

1. A violator shall not be entitled to an affirmative defense based on an alleged upset, an anticipated or unanticipated bypass, or a testing or laboratory error to the extent that the violation is caused by operational

error, improperly designed treatment facilities, inadequate treatment facilities, lack of preventive maintenance, or careless or improper operation.

2. A violator shall be entitled to an affirmative defense only if, in the determination of the Department, the violator satisfies the following:

- i. The violation occurred as a result of an upset, an anticipated or unanticipated bypass, or a testing or laboratory error;
- ii. The violator complied with all of the requirements in N.J.A.C. 7:14A-3.10;
- iii. The violator complied with N.J.A.C. 7:14-8.4(a)7; and
- iv. A violator asserting a testing or laboratory error as an affirmative defense shall also have the burden to demonstrate that a violation involving the exceedance of an effluent limitation was the result of unanticipated test interferences, sample contamination, analytical defects, or procedural deficiencies in sampling or other similar circumstances beyond the violator's control.

3. If the Department determines that an exceedance of an effluent limitation was caused by an upset, an anticipated or unanticipated bypass, or a testing or laboratory error, the Department shall not consider the exceedance a violation and the Department shall not assess a civil administrative penalty.

4. The Department shall consider the exceedance of an effluent limitation a violation if the Department determines that any of the following conditions exist:

- i. The exceedance was not caused by an upset, an anticipated or unanticipated bypass, or a testing or laboratory error;
- ii. The violator has not complied with the reporting requirements in N.J.A.C. 7:14A-3.10; or
- iii. The violator has not complied with N.J.A.C. 7:14A-8.4(a)7.

Amended by R.1989 d.282, effective June 5, 1989.

See: 21 N.J.R. 373(a), 21 N.J.R. 1530(a).

Added (c).

Amended by R.1991 d.378, effective August 5, 1991.

See: 23 N.J.R. 1089(a), 23 N.J.R. 2366(a).

Added "and affirmative defenses" in heading. In (b)1, added "and is deemed received". Added (c), (d), (g), (h), (i). Recodified existing (c) as (e) with substantial additions. Reconstructed new (f) from former (c).

Administrative correction to (i)2iii.

See: 24 N.J.R. 2448(a).

Amended by R.1994 d.277, effective June 6, 1994.

See: 25 N.J.R. 5395(a), 26 N.J.R. 2461(a).

Amended by R.1995 d.162, effective March 20, 1995.

See: 26 N.J.R. 4912(a), 27 N.J.R. 1265(a).

Amended by R.1997 d.106, effective May 5, 1997.

See: 28 N.J.R. 720(a), 28 N.J.R. 2779(a), 28 N.J.R. 3040(a), 28 N.J.R. 3494(a), 28 N.J.R. 4697(a), 29 N.J.R. 1691(c).

In (h), amended Appendix reference.

Case Notes

Citizen suit for violations of federal Water Pollution Control Act permit; prior state enforcement action against violator. Public Interest Research Group of New Jersey, Inc. v. New Jersey Expressway Authority, D.N.J.1992, 822 F.Supp. 174.

New Jersey Department of Environmental Protection order and notice, was "commencement" of enforcement proceeding by Department for purposes of Clean Water Act. Public Interest Research Group of New Jersey, Inc. v. Elf Atochem North America, Inc., D.N.J.1993, 817 F.Supp. 1164.

Chromium exceedances warranted assessment of \$197,630 in penalties against chemical company. Department of Environmental Protection v. CPS Chemical, 95 N.J.A.R.2d (EPE) 194.

Discharge monitoring ordered as part of penalty found proper exercise of Commissioner's authority. Dept. of Environmental Protection v. Kearney Industries, 3 N.J.A.R. 339 (1981).

7:14-8.3A Public comment on interim enforcement limits

(a) The procedures for soliciting public comment on proposed interim enforcement limits in administrative consent orders are provided in this section.

1. The Department will require the violator to provide notice of proposed interim enforcement limits and of an opportunity, for at least 30 days from the publication of the notice, to comment on the proposal.

2. The violator shall submit to the Department a proposed plan to provide the public notice required in (b) through (d) below.

3. Upon the violator's receipt of the Department's written approval of the violator's plan to provide public notice, the violator shall provide the public notice as approved by the Department.

(b) The violator shall provide the following public notice of the proposed interim enforcement limits:

1. At least three days prior to publication of the public notice required in (b)2 below, the violator shall mail a copy of the public notice and the draft administrative consent order or other document which includes the proposed interim enforcement limits to:

i. The mayor or chief executive officer and governing body of the municipality and county in which the violations occurred; and

ii. Any other interested persons the Department identifies.

2. The violator shall publish the public notice in a daily or weekly newspaper within the area affected by the facility which is the subject of the interim enforcement limits.

(c) The violator shall include the following in the public notice:

1. The name and address of the violator upon which the Department will impose the interim enforcement limits;

2. The beginning and ending dates of the public comment period;

3. A description of the nature of the violations necessitating the interim enforcement limits;

4. A summary of the terms and conditions of the legal document in which the interim enforcement limits is contained;

5. The name of the contact person within the Department to contact for more information;

6. The requirement that anyone submitting written comments on the proposed interim enforcement limits shall submit copies of the written comments to both the Department and the violator; and

7. The name and address of the person for the Department and the violator to whom members of the public may submit written comments.

(d) If the Department decides to hold a public meeting on the proposed interim enforcement limits:

1. The violator shall also include in the public notice:

i. The date, time and place of the public meeting; and

ii. A brief description of the nature and purpose of the public meeting, including the applicable rules and procedures;

2. The violator shall publish notice of the public meeting not more than 30 days and not less than 15 days prior to the public meeting;

3. The Department shall hold the public meeting in the municipality in which the violations necessitating the interim enforcement limits occurred;

4. The violator shall attend and participate in the public meeting at the Department's request; and

5. The violator shall, with the prior written approval of the Department, make all necessary arrangements for scheduling and holding the public meeting, including, but not limited to:

i. Scheduling of the meeting room;

ii. Arranging for a court stenographer to record the statements at the public meeting; and

iii. Payment of all costs of the public meeting, including, but not limited to, hearing room costs, security, stenographer, transcript, and the Department's cost associated with the public meeting.

(e) The violator shall submit to the Department proof of publication prior to the Department issuing an administrative order or executing the administrative consent order which includes an interim enforcement limits.

(f) After receiving the comments, but before executing an administrative order or an administrative consent order which includes the interim enforcement limits, the Department will:

1. Evaluate each of the comments received;
2. Respond to the comments received; and
3. Notify each person who submitted written comments of the main provisions of the administrative order or administrative consent order and the final interim enforcement limits and a copy of the Department's responses to the comments.

New Rule, R.1991 d.378, effective August 5, 1991.
See: 23 N.J.R. 1089(a), 23 N.J.R. 2366(a).

7:14-8.4 Procedures to request an adjudicatory hearing to contest an administrative order, a notice of civil administrative penalty assessment or a notice of civil administrative cost assessment; procedures for conducting adjudicatory hearings

(a) To request an adjudicatory hearing to contest an administrative order, a notice of civil administrative penalty assessment, or a notice of civil administrative cost assessment issued pursuant to the Water Pollution Control Act, the New Jersey Underground Storage of Hazardous Substances Act, or the Water Supply and Wastewater Operators' Licensing Act, the violator shall submit the following information in writing to the Department at Office of Legal Affairs, ATTENTION: Adjudicatory Hearing Requests, Department of Environmental Protection, PO Box 402, Trenton, New Jersey 08625-0402:

1. The name, address, and telephone number of the violator and its authorized representative;
2. The violator's defenses to each of the findings of fact stated in short and plain terms;
3. An admission or denial of each of the findings of fact. If the violator is without knowledge or information sufficient to form a belief as to the truth of a finding, the violator shall so state and this shall have the effect of a denial. A denial shall fairly meet the substance of the findings denied. When the violator intends in good faith to deny only a part or a qualification of a finding, the violator shall specify so much of it as is true and material and deny only the remainder. The violator may not generally deny all of the findings but shall make all denials as specific denials of designated findings. For each finding the violator denies, the violator shall allege the fact or facts as the violator believes it or them to be;
4. Information supporting the request and specific reference to or copies of other written documents relied upon to support the request;
5. An estimate of the time required for the hearing (in days and/or hours);
6. A request, if necessary, for a barrier-free hearing location for physically disabled persons;

7. Proof of compliance with all of the requirements in N.J.A.C. 7:14A-3.10 if the violator intends to:

- i. Raise an affirmative defense to liability for a civil administrative penalty pursuant to N.J.A.C. 7:14-8.5(a) or 8.9(e) for the violation of an effluent limitation on the basis that a violation of an effluent limitation occurred as a result of an upset, an approved anticipated bypass or unanticipated bypass, or a testing or laboratory error; and
- ii. To request that the Department determine through an administrative hearing whether or not it agrees with the violator's allegations concerning the matter; and

8. For a notice of civil administrative penalty assessment pursuant to N.J.A.C. 7:14-8.9(e), the following as applicable:

- i. Documentation of compliance with the requirements in N.J.A.C. 7:14-8.9(e) that the violator notify the Department in writing, within 30 days after the date the violator was required to submit the information to the Department, of extenuating circumstances that prevented timely submission of a complete discharge monitoring report;
- ii. Documentation of the violator's correction of the violation by submitting the omitted information within 10 days after the violator's receipt of the notice of the omission; a violator's failure to comply with the notice requirements in N.J.A.C. 7:14-8.9(e) will be a waiver of the violator's right to correct the violation within the required 10-day period and thus avert liability; or
- iii. If the violator intends to contest a civil administrative penalty assessed pursuant to N.J.A.C. 7:14-8.9(e) based on the existence of extenuating circumstances beyond the violator's control, documentation that the violator complied with N.J.A.C. 7:14-8.9(e)3; if the violator fails to submit the required information within this 30-day period, the violator shall have waived its right to contest the civil administrative penalty in this manner and be barred from doing so.

(b) The Department shall deny the hearing request if the Department does not receive a complete hearing request pursuant to (a) above within 20 days after receipt by the violator of the Notice of a Civil Administrative Penalty Assessment, the Administrative Order, or Notice of Civil Administrative Cost Assessment being challenged. A violator's failure to notify the Department in writing, within the 30 days allotted under (a)8i above, of the existence of extenuating circumstances which prevented timely submission of a complete discharge monitoring report, shall be grounds for the Department to deny any hearing request on a notice of civil administrative penalty assessment pursuant to N.J.A.C. 7:14-8.9(e).

(c) All adjudicatory hearings held pursuant to this section shall be conducted in accordance with the Administrative Procedure Act, N.J.S.A. 52:14B-1 et seq., and the Uniform Administrative Procedure Rules, N.J.A.C. 1:1.

Amended by R.1991 d.378, effective August 5, 1991.

See: 23 N.J.R. 1089(a), 23 N.J.R. 2366(a).

Added "or a notice of civil administrative cost assessment" to heading and in (a) and (b).

Added (a)7, 8, 9.

In (b), added "A violator's failure . . . pursuant to N.J.A.C. 7:14-8.9(e)".

Deleted (c).

Recodified existing (d) as (c).

Administrative Change in (a).

See: 23 N.J.R. 3325(b).

Administrative Correction to N.J.A.C. 7:14-8.4(a)9i and ii.

See: 23 N.J.R. 3754(a).

Administrative Correction to N.J.A.C. 7:14-8.4(a)9ii.

See: 25 N.J.R. 2862(b).

Amended by R.1995 d.162, effective March 20, 1995.

See: 26 N.J.R. 4912(a), 27 N.J.R. 1265(a).

Amended by R.1999 d.32, effective January 19, 1999.

See: 30 N.J.R. 1356(a), 31 N.J.R. 157(a).

In (a), deleted "and Energy" following "Environmental Protection" and updated the address in the introductory paragraph and deleted a former 9.

Law Review and Journal Commentaries

Environmental Law—Administrative Law. Steven P. Bann, No. 2, 138 N.J.L.J. 54 (1994).

Case Notes

State administrative action brought against polluter by New Jersey Department of Environmental Protection was not "comparable" to an action brought under Clean Water Act, and, thus, state administrative action did not bar citizens' suit under Act where there had been no previous provision for public comment or hearing. Public Interest Research Group of New Jersey, Inc. v. GAF Corp., D.N.J.1991, 770 F.Supp. 943.

State administrative action was not comparable to action brought under Clean Water Act. Public Interest Research Group of New Jersey, Inc. v. GAF Corp., D.N.J.1991, 770 F.Supp. 943.

Posting of financial assurance for potential penalty as condition to obtaining hearing violated due process. and Energy, 275 N.J.Super. 342, 646 A.2d 447 (A.D.1994).

Statutory 20-day time limit for requesting adjudicatory hearing on notice of administrative penalty for violation of pollutant discharge permit was mandatory and jurisdictional. Schaible Oil Co., Inc. v. New Jersey Dept. of Environmental Protection, 246 N.J.Super. 29, 586 A.2d 853 (A.D.1991), certification denied 126 N.J. 387, 599 A.2d 163.

7:14-8.5 Civil administrative penalty determination

(a) The Department may assess a civil administrative penalty pursuant to this section of not more than \$50,000 for each violation of each provision of the Water Pollution Control Act or the New Jersey Underground Storage of Hazardous Substances Act and for violations of any rule, water quality standards, effluent limitation, administrative order or permit issued pursuant thereto. The Department shall assess a minimum mandatory civil administrative penalty for violations which occur after June 30, 1991 in an amount:

1. Not less than \$5,000 for each violation that causes a violator to be, or continue to be, a significant noncomplier; or
2. Not less than \$1,000 for each serious violation.

(b) Each violation of any provision of the Water Pollution Control Act or the New Jersey Underground Storage of Hazardous Substances Act, or any rule, water quality standard, effluent limitation, administrative order or permit issued pursuant thereto, shall constitute an additional, separate and distinct violation. In addition, the unpermitted discharge of each separate pollutant shall constitute an additional, separate and distinct violation. If a violator establishes, to the satisfaction of the Department, that a single operational occurrence has resulted in the simultaneous violation of more than one effluent limit, the Department may consider, for purposes of calculating the mandatory civil administrative penalties to be assessed pursuant to (a) above, the violation of interrelated effluent limits to be a single violation.

(c) Each day during which a violation as set forth in (b) above continues shall constitute an additional, separate and distinct violation.

(d) Unless the Department assesses a civil administrative penalty pursuant to N.J.A.C. 7:14-8.6 through N.J.A.C. 7:14-8.12, the Department shall assess a civil administrative penalty for violations described in this section as described in (e) below.

(e) To assess a civil administrative penalty pursuant to this section, the Department shall:

1. Identify the civil administrative penalty range within the matrix in (f) below by:
 - i. Determining the seriousness of the violation pursuant to (g) below; and
 - ii. Determining the conduct of the violator pursuant to (h) below.

2. The civil administrative penalty shall be at the midpoint of the range within the matrix in (f) below, unless adjusted pursuant to (i) below.

(f) The matrix of ranges of civil administrative penalties is as follows:

		SERIOUSNESS		
		Major	Moderate	Minor
CONDUCT	Major	\$40,000-\$50,000	\$30,000-\$40,000	\$15,000-\$25,000
	Moderate	\$30,000-\$40,000	\$10,000-\$20,000	\$ 3,000-\$ 7,000
	Minor	\$15,000-\$25,000	\$ 3,000-\$ 7,000	\$ 1,000-\$ 2,500

(g) The Department shall determine the seriousness of the violation as major, moderate or minor as set forth in (g)1 through 3 below. Nothing in the description of seriousness in one level shall prevent the Department from assigning a different level of seriousness to the violation.

1. Major shall include:

i. Any violation of an effluent limitation which is measured by concentration or mass for any discharge exceeding the effluent limitation as follows:

(1) By more than 50 percent for a hazardous pollutant; or

(2) By more than 100 percent for a nonhazardous pollutant;

ii. The greatest violation of a pH effluent range in any one calendar day which violation deviates from the midpoint of the range by more than 50% of the midpoint of the range excluding the excursions specifically excepted by a NJPDES permit with continuous pH monitoring; and

iii. Any other violation not included in (g)1i or ii above which either:

(1) Has caused or has the potential to cause serious harm to human health or the environment; or

(2) Seriously deviates from the requirements of the Water Pollution Control Act or the New Jersey Underground Storage of Hazardous Substances Act and for violations of any rule, water quality standards, effluent limitation, administrative order or permit issued pursuant thereto; serious deviation shall include, but not be limited to, those violations which are in complete contravention of the requirement, or if some of the requirement is met, which severely impair or undermine the operation or intent of the requirement.

iv. Any violation which seriously deviates from a requirement of the Water Pollution Control Act, the New Jersey Underground Storage of Hazardous Substances Act, or any rule, water quality standard, effluent limitation, administrative order or permit now or hereafter issued pursuant thereto; serious deviation shall include, but not be limited to, those violations which are in complete contravention of the requirement, or if

some of the requirement is met, which severely impair or undermine the operation or intent of the requirement.

2. Moderate shall include:

i. Any violation, other than a violation of an effluent limitation identified in (g)2ii or iii below, which has caused or has the potential to cause substantial harm to human health or the environment;

ii. Any violation of an effluent limitation which is measured by concentration or mass of any discharge exceeding the effluent limitation as follows:

(1) By 20 to 50 percent for a hazardous pollutant; or

(2) By 40 to 100 percent for a nonhazardous pollutant;

iii. The greatest violation of a pH effluent range in any one calendar day which violation deviates from the midpoint of the range by at least 40 percent but no more than 50 percent of the midpoint of the range excluding the excursions specifically excepted by a NJPDES permit with continuous pH monitoring; or

iv. Any violation, other than a violation of an effluent limitation identified in (g)2ii or iii above, which substantially deviates from the requirements of the Water Pollution Control Act or the New Jersey Underground Storage of Hazardous Substances Act and for violations of any rule, water quality standards, effluent limitation, administrative order or permit issued pursuant thereto; substantial deviation shall include, but not be limited to, violations which are in substantial contravention of the requirements or which substantially impair or undermine the operation or intent of the requirement.

3. Minor shall include:

i. Any violation, other than a violation of an effluent limitation identified in (g)3ii or iii below, not included in (g)1 or 2 above; or

ii. Any violation of an effluent limitation which is measured by concentration or mass for any discharge exceeding the effluent limitation as follows:

(1) By less than 20 percent for a hazardous pollutant; or

(2) By less than 40 percent for a nonhazardous pollutant; or

iii. The greatest violation of a pH effluent range in any one calendar day which violation deviates from the midpoint of the range by less than 40 percent of the midpoint of the range excluding the excursions specifically excepted by a NJPDES permit with continuous pH monitoring.

(h) The Department shall determine the conduct of the violator as major, moderate or minor as follows:

1. Major shall include any intentional, deliberate, purposeful, knowing or willful act or omission by the violator;
2. Moderate shall include any unintentional but foreseeable act or omission by the violator; or
3. Minor shall include any other conduct not included in (h)1 or 2 above.

(i) The Department may, in its discretion, move from the midpoint of the range to an amount no greater than the maximum amount nor less than the minimum amount in the range on the basis of the following factors:

1. The compliance history of the violator;
2. The number, frequency and severity of the violation(s);
3. The measures taken by the violator to mitigate the effects of the current violation or to prevent future violations;
4. The deterrent effect of the penalty;
5. The cooperation of the violator in correcting the violation, remedying any environmental damage caused by the violation and ensuring that the violation does not reoccur;
6. Any unusual or extraordinary costs or impacts directly or indirectly imposed on the public or the environment as a result of the violation;
7. Any impacts on the receiving water, including stress upon the aquatic biota, or impairment of receiving water uses, such as for recreational or drinking water supply, resulting from the violation; and
8. Other specific circumstances of the violator or violation.

Amended by R.1989 d.282, effective June 5, 1989.
See: 21 N.J.R. 373(a), 21 N.J.R. 1530(a).

(d)-(f) recodified as (e)-(g), new (c) added regarding each day continuing constituting separation violation.

Amended by R.1991 d.307, effective June 17, 1991.
See: 22 N.J.R. 2870(a), 23 N.J.R. 1926(a).

Added (e)1iii and (e)2iii.

Amended by R.1991 d.378, effective August 5, 1991.
See: 23 N.J.R. 1089(a), 23 N.J.R. 2366(a).

In (a), added penalty amounts for violations occurring after June 30, 1991.

In (b), added "If a violator establishes . . . to be a single violation".

In (d), substituted old text for new text with retention of chart. Changed the \$6,000 penalty assessments in the chart to \$7,000.

Recodified existing (e) as (g) with substantial additions.

Deleted (g)1i; recodified existing (g)1ii as i.

Added (g)1ii and (g)2ii.

In (g)2i, added " , other than a violation of an effluent limitation identified in (g)2ii below."

In (g)2ii(1), changed "26" to "20".

In (g)2ii(2), changed "51" to "40".

In (g)3i, added " , other than a violation of an effluent limitation identified in (g)3ii or iii below."

In (g)3ii(1), changed "up to 25" to "less than 20".

In (g)3ii(2), changed "up to 50" to "less than 40".

Recodified existing (f) and (g) as (h) and (i).

In (i), changed "adjust the amount determined pursuant to (d) above to assess a civil administrative penalty in" to "move from the midpoint of the range to". Substituted (i)5 with new text and added (i)6, 7 and 8. Amended by R.1992 d.145, effective April 6, 1992.

See: 23 N.J.R. 2238(a), 24 N.J.R. 1334(a).

pH effluent ranges added.

Case Notes

In assessing penalty under federal Clean Water Act, rebuttable presumption of adequacy will be given to state Department of Environmental Protection's penalty assessment for violations of Jersey Water Pollution Act if there has been meaningful degree of citizen participation, individualized determination based on all relevant facts, and resulting remedy sufficient to abate and deter pollution. Public Interest Research Group of New Jersey, Inc. v. Hercules, Inc., 970 F.Supp. 363 (D.N.J.1997.)

Penalty for violation of permit upheld when maximum boron discharge limits exceeded. Department of Environmental Protection v. Florence Land Recontouring Company, Inc., 97 N.J.A.R.2d (EPE) 17.

Penalty assessment for exceedances of effluent limitations were reduced for remedial efforts and "upset" from sewer blockage. Department of Environmental Protection v. Harding Woods, 95 N.J.A.R.2d (EPE) 195.

Chemical company failed to show that permit exceedance violations were laboratory error. Department of Environmental Protection v. CPS Chemical Company, Inc., 94 N.J.A.R.2d (EPE) 218.

Penalty assessed against county when county repeatedly exceeded limits established by environmental permit. DEPE v. Cumberland County Improvement Authority, 94 N.J.A.R.2d (EPE) 45.

Pipe foundry exceeded effluent limitations set forth in permit. DEPE v. Griffin Pipe Products Co., 93 N.J.A.R.2d (EPE) 251.

Discharges by quarry of crusher waters constituted violations of Water Pollution Control Act; penalty assessed. Division of Water Resources v. Tilcon New Jersey, Inc. 93 N.J.A.R.2d (EPE) 245.

Penalty of \$1,750 for violation by car wash of permit condition was appropriate. Gem Car Wash v. Department of Environmental Protection. 93 N.J.A.R.2d (EPE) 234.

Former regulation imposed duty on town to cease sewer extension approvals if ban criteria were met; penalty regulation effective when Department discovered violations and assessed penalties governed penalty assessment. Department of Environmental Protection v. Town of Newton. 93 N.J.A.R.2d (EPE) 167.

Failure to submit timely and adequate notice of force majeure occurrences; violation of effluent limitations not excused. Evesham Municipal Utilities Authority v. New Jersey Department of Environmental Protection, 92 N.J.A.R.2d (EPE) 222.

Operator of pork slaughtering and packaging facility violated wastewater permit; civil administrative penalties. New Jersey Department of Environmental Protection v. Triolo Brothers, Inc., 92 N.J.A.R.2d (EPE) 1.

7:14-8.6 Civil administrative penalty for submitting inaccurate or false information

(a) The Department may assess a civil administrative penalty pursuant to this section against each violator who submits inaccurate information or who makes a false statement, representation, or certification in any application, record, or other document required to be submitted or maintained, or who falsifies, tampers with or renders inaccurate any monitoring device or method required to be maintained under the Water Pollution Control Act or the New Jersey Underground Storage of Hazardous Substances Act or any rule, water quality standard, effluent limitation, administrative order or permit issued pursuant thereto.

(b) Each day, from the day of submittal by the violator of the false or inaccurate information to the Department to the day of receipt by the Department of a written correction by the violator shall be an additional, separate and distinct violation.

(c) The Department shall assess a civil administrative penalty for violations described in this section based on the conduct of the violator at the midpoint of the following ranges except as adjusted pursuant to (d) below:

1. For each intentional, deliberate, purposeful knowing or willful act or omission by the violator, the civil administrative penalty shall be in an amount up to \$50,000 per act or omission;
2. For each other violation not identified pursuant to (c)1 above for which the violator does not correct the violation within 10 days after becoming aware of the violation, the civil administrative penalty shall be in an amount up to \$30,000; and
3. For each other violation not identified pursuant to (c)1 above for which the violator corrects the violation within 10 days after becoming aware of the violation, the civil administrative penalty shall be in an amount up to \$1,000.

(d) The Department may, in its discretion, adjust the amount determined pursuant to (c) above to assess a civil administrative penalty in an amount no greater than the maximum amount nor less than the minimum amount in the range on the basis of the following factors:

1. The compliance history of the violator;
2. The number, frequency and severity of the violations;
3. The measures taken by the violator to mitigate the effects of the current violation or to prevent future violations;
4. The deterrent effect of the penalty;
5. The cooperation of the violator in correcting the violation, remedying any environmental damage caused by the violation and ensuring that the violation does not reoccur;
6. Any unusual or extraordinary costs or impacts directly or indirectly imposed on the public or the environment as a result of the violation;
7. Any impacts on the receiving water, including stress upon the aquatic biota, or impairment of receiving water uses, such as for recreational or drinking water supply, resulting from the violation; and
8. Other specific circumstances of the violator or violation.

Amended by R.1989 d.282, effective June 5, 1989.

See: 21 N.J.R. 373(a), 21 N.J.R. 1530(a).

Language added at (c) regarding assessing penalty at mid-point of ranges and new (d) added.

Amended by R.1991 d.378, effective August 5, 1991.

See: 23 N.J.R. 1089(a), 23 N.J.R. 2366(a).

In (c)1, changed penalty to "up to \$50,000".

Added (c)2.

Recodified existing (c)2 as 3 and added "not identified pursuant to (c)1 above for which the violator corrects the violation within 10 days after becoming aware of the violation".

Deleted (d)5 and substituted new text.

Added (d)6, 7 and 8.

Case Notes

Penalty assessment for exceedances of effluent limitations were reduced for remedial efforts and "upset" from sewer blockage. Department of Environmental Protection v. Harding Woods, 95 N.J.A.R.2d (EPE) 195.

7:14-8.7 Civil administrative penalty for failure to allow lawful entry and inspection

(a) The Department may assess a civil administrative penalty pursuant to this section against each violator who refuses, inhibits or prohibits immediate lawful entry and inspection of any premises, building or place by any authorized Department representative.

(b) Each day, from the initial day of failure by the violator to allow immediate lawful entry and inspection to the day of receipt by the Department of written notification from the violator that the violator will not refuse, inhibit or prohibit immediate lawful entry and inspection, shall be an additional, separate and distinct violation.

(c) The Department shall assess a civil administrative penalty for violations described in this section at the midpoint of the following ranges except as adjusted pursuant to (d) below:

1. For refusing, inhibiting or prohibiting immediate lawful entry and inspection of any premises, building or place for which an administrative order or permit exists under the Water Pollution Control Act or the New Jersey Underground Storage of Hazardous Substances Act, the civil administrative penalty shall be in an amount up to \$50,000; and
2. For any other refusal, inhibition or prohibition of immediate lawful entry and inspection, the civil administrative penalty shall be in an amount up to \$8,000.

(d) The Department may, in its discretion, adjust the amount determined pursuant to (c) above to assess a civil administrative penalty in an amount no greater than the maximum amount nor less than the minimum amount in the range on the basis of the following factors:

1. The compliance history of the violator;
2. The number, frequency and severity of the violations;
3. The measures taken by the violator to mitigate the effects of the current violation or to prevent future violations;
4. The deterrent effect of the penalty;

5. The cooperation of the violator in correcting the violation, remedying the damage caused by the violation and ensuring that the violation does not reoccur;

6. Any unusual or extraordinary costs or impacts directly or indirectly imposed on the public or the environment as a result of the violation;

7. Any impacts on the receiving water, including stress upon the aquatic biota, or impairment of receiving water uses, such as for recreational or drinking water supply, resulting from the violation; and

8. Other specific circumstances of the violator or violation.

Amended by R.1989 d.282, effective June 5, 1989.

See: 21 N.J.R. 373(a), 21 N.J.R. 1530(a).

The word "lawful" added before "entry" wherever it appears; language regarding assessing penalty at mid-point of ranges and new (d) added.

Amended by R.1991 d.378, effective August 5, 1991.

See: 23 N.J.R. 1089(a), 23 N.J.R. 2366(a).

In (c)1, changed penalty amount to "up to \$50,000".

In (c)2, changed penalty amount to "up to \$8,000".

Deleted (d)5 and substituted new text.

Added (d)6, 7 and 8.

7:14-8.8 Civil administrative penalty for conducting unapproved activities

(a) The Department may assess a civil administrative penalty pursuant to this section against each violator who approves, endorses, allows construction or operation to commence or proceed, builds, modifies, installs, replaces, expands or operates a facility or treatment works, as defined by N.J.A.C. 7:14A, without the proper authorization or in violation of any rule, administrative order, sewer connection ban, or permit issued or imposed pursuant to the Water Pollution Control Act.

(b) The Department shall determine the amount of the civil administrative penalty for violations described in this section based on the seriousness of the violation and the conduct of violator based on the following:

1. For any unauthorized approval, endorsement or allowance to commence or proceed to build, modify, install, replace, expand or operate a facility or treatment works the civil administrative penalty shall be in an amount determined as follows:

$$\text{civil administrative penalty} = (\text{seriousness}) \times (\text{conduct}) \times (\$1.00)$$

i. The seriousness factor shall be equal to one-half of the design flow (in gallons per day) indicated in the CP-1 Permit Application for that facility or project, or if there is no CP-1 Permit Application or if the design flow is not indicated on the CP-1 Application, then from the Contributory Design Flow table in N.J.A.C. 7:9-1; and

ii. The conduct factor is either:

(1) 1.00 if the conduct is intentional, deliberate, purposeful, knowing or willful; or

(2) 0.75 for any other conduct.

iii. Each approval, endorsement or allowance to commence or proceed shall be considered an additional, separate and distinct violation;

2. For the building, installation, modification, replacement or expansion of a facility or treatment works without the required Department approval, the civil administrative penalty shall be in an amount determined as follows:

$$\text{civil administrative penalty} = (\text{seriousness}) \times (\text{conduct}) \times (\$1.00)$$

i. The seriousness factor shall be equal to one-half of the design flow (in gallons per day) as determined from the CP-1 Permit Application for that facility or project, or if there is no CP-1 Permit Application or if the design flow is not indicated on the CP-1 Application, then from the Contributory Design Flow table in N.J.A.C. 7:9-1.

ii. The conduct factor is either:

(1) 1.00 if the conduct is intentional, deliberate, purposeful, knowing or willful; or

(2) 0.75 for any other conduct.

iii. Each day or part thereof that the construction of the facility or treatment works continues without the required Department approval shall be considered an additional, separate and distinct violation.

3. For the operation of any facility or treatment works, the civil administrative penalty shall be in an amount equal to, at the sole discretion of the Department, either:

i. Twice the total penalty for the illegal building, installation, modification, replacement or expansion of a facility of treatment works calculated pursuant to (b)2 above; or

ii. Equal to the product of the following equation:

$$\text{civil administrative penalty} = (\text{seriousness}) \times (\text{conduct}) \times (\$1.00)$$

(1) The seriousness factor shall be equal to the total design flow (in gallons per day) as determined from the CP-1 Permit Application for that facility or project, or if there is no CP-1 Permit Application or if the design flow is not indicated on the CP-1 Application, then from the Contributory Design Flow table in N.J.A.C. 7:9-1.

(2) The conduct factor shall be either:

(A) 1.00 if the conduct is intentional, deliberate, purposeful, knowing or willful; or

(B) 0.75 for any other conduct.

(3) Each day or part thereof that the operation of the facility or treatment works continues without the required Department approval shall be considered an additional, separate and distinct violation.

Amended by R.1989 d.282, effective June 5, 1989.

See: 21 N.J.R. 373(a), 21 N.J.R. 1530(a).

Cite to N.J.A.C. added in (b) and language regarding seriousness of violation and conduct of violator.

Amended by R.1991 d.378, effective August 5, 1991.

See: 23 N.J.R. 1089(a), 23 N.J.R. 2366(a).

In (a), added "allows construction or operation to commence or proceed," "installs, replaces, expands"; "sewer connection ban"; "or imposed"; deleted "-1 et seq." in code citation.

Deleted (a)2.

In (b), deleted "in accordance with N.J.A.C. 7:14-8.5 or".

Substituted old text for new text in (b)1, 2, 3.

Case Notes

Former regulation imposed duty on town to cease sewer extension approvals if ban criteria were met; penalty regulation effective when Department discovered violations and assessed penalties governed penalty assessment. Department of Environmental Protection v. Town of Newton. 93 N.J.A.R.2d (EPE) 167.

7:14-8.9 Civil administrative penalty for failure to properly conduct monitoring or sampling under the Water Pollution Control Act or the New Jersey Underground Storage of Hazardous Substances Act

(a) The Department may assess a civil administrative penalty pursuant to this section against each violator who fails to carry out monitoring or sampling activities or to submit discharge monitoring reports, baseline monitoring reports, monitoring report forms or sludge quality assurance reports required by the Water Pollution Control Act or the New Jersey Underground Storage of Hazardous Substances Act or any rule, water quality standard, effluent limitation, administrative order or permit issued pursuant thereto.

(b) Each violation, including each parameter that is required to be monitored, sampled and reported and that is not monitored, sampled and reported, is an additional, separate and distinct violation. Each day during which a violation continues shall constitute an additional, separate and distinct violation.

(c) Except as provided in (e) below, the Department shall assess a civil administrative penalty for violations described in this section based on the conduct of the violator at the midpoint of the following ranges except as adjusted pursuant to (d) below:

1. For any intentional, deliberate, purposeful, knowing or willful act or omission by the violator, the civil administrative penalty shall be in an amount up to \$50,000;
2. For any unintentional but foreseeable act or omission by the violator, the civil administrative penalty shall be in amount up to \$40,000; or
3. For any other violations the civil administrative penalty shall be in an amount up to \$20,000.

(d) The Department may, in its discretion, adjust the amount determined pursuant to (c) above to assess a civil administrative penalty in an amount no greater than the maximum amount nor less than the minimum amount in the range on the basis of the following factors:

1. The compliance history of the violator;
2. The number, frequency and severity of the violation(s);
3. The measures taken by the violator to mitigate the effects of the current violation or to prevent future violations;
4. The deterrent effect of the penalty;
5. The cooperation of the violator in correcting the violation remedying the damage caused by the violation and ensuring that the violation does not reoccur;
6. Any unusual or extraordinary costs or impacts directly or indirectly imposed on the public or the environment as a result of the violation;
7. Any impacts on the receiving water, including stress upon the aquatic biota, or impairment of receiving water uses, such as for recreational or drinking water supply, resulting from the violation; and
8. Other specific circumstances of the violator or violation.

(e) For any person's failure to submit a complete discharge monitoring report, the Department shall assess a minimum mandatory civil administrative penalty of not less than \$100.00 for each effluent parameter omitted on a discharge monitoring report, nor greater than \$50,000 per month for any one discharge monitoring report, for any discharge monitoring report required to be submitted after June 30, 1991.

1. The civil administrative penalty assessed pursuant to (e) above shall begin to accrue on the fifth day after the date on which the discharge monitoring report was due and shall continue to accrue at least for 30 days if the violation is not corrected.
2. The Department may continue to assess civil administrative penalties for the failure to submit a complete discharge monitoring report beyond the 30-day period referenced in (e)1 above until the violation is corrected.
3. To contest a civil administrative penalty assessed pursuant to this section, a violator shall submit evidence of extenuating circumstances beyond the control of the permittee, including circumstances that prevented timely submission of a complete discharge monitoring report, or portion thereof, within 30 days after the date on which the effluent parameter information was required to be submitted to the Department. If the violator fails to submit the required information within this 30-day period, the violator shall have waived its right to contest the

civil administrative penalty in this manner and be barred from doing so.

4. A violator will not be subject to a civil administrative penalty for the inadvertent omission of one or more effluent parameters in a discharge monitoring report if both of the following conditions are met:

i. The violator submits the omitted information to the Department within 10 days after receipt by the violator of notice of the omission; and

ii. The violator demonstrates to the satisfaction of the Department that the violation for which the Department assessed the civil administrative penalty was due to an inadvertent omission by the violator of one or more effluent parameters.

Amended by R.1989 d.282, effective June 5, 1989.
See: 21 N.J.R. 373(a), 21 N.J.R. 1530(a).

Language added at (b) regarding each day constituting a separate violation and at (d), new 5.

Amended by R.1991 d.378, effective August 5, 1991.
See: 23 N.J.R. 1089(a), 23 N.J.R. 2366(a).

In (a), added "discharge monitoring reports, baseline monitoring reports, monitoring report forms or sludge quality assurance reports".

In (c), added "Except as provided in (e) below".

In (c)1, changed penalty amount to "up to \$50,000".

In (c)2, changed penalty amount to "up to \$40,000".

In (c)3, changed penalty amount to "up to \$20,000".

Substituted old text with new text in (d)5 and added 6, 7, 8.

Added (e).

Case Notes

Failure to properly monitor, sample and report discharge characteristics required civil penalty assessment. Department of Environmental Protection v. East Coast Ice, 95 N.J.A.R.2d (EPE) 154.

Operator of pork slaughtering and packaging facility violated wastewater permit; civil administrative penalties. New Jersey Department of Environmental Protection v. Triolo Brothers, Inc., 92 N.J.A.R.2d (EPE) 1.

7:14-8.10 Civil administrative penalty for failure to pay a fee

(a) The Department may assess a civil administrative penalty pursuant to this section against each violator who fails to pay a fee when due pursuant to the Water Pollution Control Act or the New Jersey Underground Storage of Hazardous Substances Act.

(b) Each day a fee is not paid after it is due shall constitute an additional, separate and distinct violation.

(c) The Department shall determine the amount of the civil administrative penalty for violations described in this section based on an amount equal to the unpaid fee, up to a maximum of \$50,000 per violation.

Amended by R.1989 d.282, effective June 5, 1989.
See: 21 N.J.R. 373(a), 21 N.J.R. 1530(a).

Deleted reference to "unpaid civil administrative penalty".

Case Notes

Penalty found appropriate for failure to provide self-monitoring reports, failure to construct treatment works and continued excessive discharge of pollutants. Lentine Aggregates v. Dept. of Environmental Protection, 4 N.J.A.R. 117 (1981), affirmed per curiam Dkt. No. A-3424-80 (App.Div.1982).

Discharge monitoring ordered as part of penalty found proper exercise of Commissioner's authority. Dept. of Environmental Protection v. Kearney Industries, 3 N.J.A.R. 339 (1981).

7:14-8.11 (Reserved)

Amended by R.1989 d.282, effective June 5, 1989.

See: 21 N.J.R. 373(a), 21 N.J.R. 1530(a).

At (b), reference to each day constituting a separate violation and (d) and (e) deleted.

Repealed by R.1996 d.307, effective July 1, 1996.

See: 27 N.J.R. 4761(a), 28 N.J.R. 3330(c).

Section was "Civil administrative penalty for violation of the rules governing laboratory certification and standards of performance".

7:14-8.12 Civil administrative penalty for violation of whole effluent toxicity limitations

(a) The Department may assess a civil administrative penalty for violations of whole effluent toxicity limitations expressed as median Lethal Concentration (LC50), a No Observable Effect Concentration (NOEC), or No Measurable Acute Toxicity (NMAT) pursuant to this section.

(b) Each violation of a whole effluent toxicity limitation shall constitute an additional, separate and distinct violation.

(c) To assess a civil administrative penalty pursuant to this section the Department shall identify the civil administrative penalty range pursuant to (d) or (e) below.

(d) The Department shall determine the range for the civil administrative penalty for violations of whole effluent toxicity limitations expressed as median Lethal Concentration (LC50) or a No Observable Effect Concentration (NOEC), described in this section as follows, except as adjusted pursuant to (f) below:

1. For any violation of an LC50 or a NOEC limit included in the following table, the civil administrative penalty shall be in an amount up to \$50,000, when upon subtracting the toxicity test result from the whole effluent toxicity limit, the difference is as follows:

Whole Effluent Toxicity Limit (% Effluent)	Difference (% Effluent)
greater than or equal to 80 and less than or equal to 100	greater than or equal to 20
greater than or equal to 50 and less than 80	greater than or equal to 15
greater than 10 and less than 50	greater than or equal to 10
less than or equal to 10	greater than or equal to 9

2. For any other violation of an LC50 or a NOEC limit the civil administrative penalty shall be in an amount up to \$40,000.

(e) The Department shall assess a civil administrative penalty for violations of whole effluent toxicity limitations expressed as No Measurable Acute Toxicity (NMAT) based on the extent of the violator's exceedance of the whole effluent toxicity limitation at the midpoint of the following ranges except as adjusted pursuant to (f) below:

1. For any violation of a NMAT limit with greater than or equal to 50% mortality in any test concentration, including 100 percent effluent, the civil administrative penalty shall be in an amount up to \$50,000;
2. For any other violation of a NMAT limit the civil administrative penalty shall be in an amount up to \$40,000.

(f) The Department may, in its discretion, adjust the amount determined pursuant to (d) or (e) above to assess a civil administrative penalty in an amount no greater than the maximum amount nor less than the minimum amount in the range on the basis of the following factors:

1. The compliance history of the violator;
2. The number, frequency and severity of the violation(s);
3. The measures taken by the violator to mitigate the effects of the current violation or to prevent future violations;
4. The deterrent effect of the penalty;
5. The cooperation of the violator in correcting the violation, remedying the damage caused by the violation and ensuring that the violation does not reoccur;
6. Any unusual or extraordinary costs or impacts directly or indirectly imposed on the public or the environment as a result of the violation;
7. Any impacts on the receiving water, including stress upon the aquatic biota, or impairment of receiving water uses, such as for recreational or drinking water supply, resulting from the violation; and
8. Other specific circumstances of the violator or violation.

New Rule, R.1991 d.378, effective August 5, 1991.

See: 23 N.J.R. 1089(a), 23 N.J.R. 2366(a).

Old section 8.12 Civil administrative penalty for economic benefit recodified to 8.13.

Case Notes

Penalty assessment for exceedances of effluent limitations were reduced for remedial efforts and "upset" from sewer blockage. Department of Environmental Protection v. Harding Woods, 95 N.J.A.R.2d (EPE) 195.

7:14-8.13 Civil administrative penalty for economic benefit

(a) When the Department determines that the violator has gained an economic benefit from a violation, the De-

partment shall, in addition to any other civil administrative penalty assessed pursuant to this subchapter, include as part of a civil administrative penalty the economic benefit (in dollars) which the violator has realized as a result of not complying, or by delaying compliance, with the requirements of the Water Pollution Control Act, the New Jersey Underground Storage of Hazardous Substances Act or any rule, water quality standard, effluent limitation, administrative order or permit issued pursuant thereto.

(b) Economic benefit shall include:

1. The amount of savings realized from avoided capital or noncapital costs resulting from the violation;
2. The return earned or that may be earned on the amount of the avoided costs;
3. Any benefits accruing to the violator as a result of a competitive market advantage enjoyed by reason of the violation; and
4. Any other benefits resulting from the violation.

(c) The Department shall consider the following factors in determining economic benefit:

1. The amount of capital investments required, and whether they are one-time or recurring;
2. The amount of one-time nondepreciable expenditures;
3. The amount of annual expenses;
4. The useful life of capital;
5. Applicable tax, inflation and discount rates;
6. The amount of low interest financing, the low interest rate, and the corporate debt rate; and
7. Any other factors relevant to economic benefit.

(d) If the total economic benefit was derived from more than one violation, the total economic benefit amount may be apportioned among the violations from which it was derived so as to increase each civil administrative penalty assessment to an amount no greater than \$50,000 per violation.

Amended by R.1991 d.378, effective August 5, 1991.

See: 23 N.J.R. 1089(a), 23 N.J.R. 2366(a).

Section recodified from 8.12.

In (a), added "When the Department . . . , the Department shall"; deleted "If the total economic benefit . . . per violation".

Added (b), (c), and (d).

7:14-8.14 Civil administrative penalty for failing to comply with an information request or administrative subpoena, and the destruction of records

(a) The Department may assess a civil administrative penalty pursuant to this section against each violator who fails to completely respond to an information request or

administrative subpoena, or destroys records relating to a discharge to surface water within five years of the discharge, or to a discharge to ground water at any time without the prior written permission of the Department.

(b) Each day that the violator does not fully respond to any item in an information request or administrative subpoena and each item in an information request or administrative subpoena that is not fully responded to shall be an additional, separate and distinct violation.

(c) The Department shall assess a civil administrative penalty for each failure to completely respond to an information request or administrative subpoena in an amount up to \$50,000 based on the following factors:

1. The substantive responsiveness of the violator's response to the information request or administrative subpoena;
2. Number of items in the information request or administrative subpoena which the violator attempted to respond to;
3. Number of items in the information request or administrative subpoena which the violator did not respond to;
4. The timeliness of the violator's response; and
5. Any other relevant factors.

(d) The Department shall assess a civil administrative penalty for the destruction of records in violation of P.L. 1990, c. 28, section 15, based on the conduct of the violator at the midpoint of the following ranges:

1. For each intentional, deliberate, purposeful, knowing or willful act or omission by the violator, the civil administrative penalty shall be in an amount up to \$50,000; and
2. For each other violation not identified pursuant to (d)1 above the civil administrative penalty shall be in the amount up to \$30,000.

New Rule, R.1991 d.378, effective August 5, 1991.

See: 23 N.J.R. 1089(a), 23 N.J.R. 2366(a).

Old section 8.14 Severability, recodified to 8.16.

Law Review and Journal Commentaries

Economic Benefit Penalties Can Still Bite. Lewis Goldshore and Marsha Wolff, 154 N.J.L.J. 254 (1998).

Case Notes

Penalty found appropriate for failure to provide self-monitoring reports, failure to construct treatment works and continued excessive discharge of pollutants. *Lentine Aggregates v. Dept. of Environmental Protection*, 4 N.J.A.R. 117 (1981), affirmed per curiam Dkt. No. A-3424-80 (App.Div.1982).

7:14-8.15 (Reserved)

Amended by R.1989 d.282, effective June 5, 1989.

See: 21 N.J.R. 373(a), 21 N.J.R. 1530(a).

(d) and (e) deleted, (f) and (g) recodified as (d) and (e).

Amended by R.1991 d.378, effective August 5, 1991.

See: 23 N.J.R. 1089(a), 23 N.J.R. 2366(a).

Section recodified from 8.13.

In (b), added "the Water Supply and Wastewater Operators' Licensing Act and the Water Supply Management Act, or"; added "adopted or issued pursuant thereto,".

Added (f).

Amended by R.1995 d.162, effective March 20, 1995.

See: 26 N.J.R. 4912(a), 27 N.J.R. 1265(a).

Repealed by R.1997 d.48, effective February 3, 1997.

See: 28 N.J.R. 4300(a), 29 N.J.R. 480(c).

Section was "Water Supply and Wastewater Operators' Licensing Act civil administrative penalties".

7:14-8.16 Civil administrative penalty determination for indirect dischargers

(a) The Department may assess a civil administrative penalty against any indirect discharger of not more than \$50,000, for each violation of each provision of the Water Pollution Control Act and for each violation of any rule, pretreatment standard, effluent limitation, administrative order or permit issued pursuant thereto. The Department shall assess a minimum mandatory civil administrative penalty in an amount:

1. Not less than \$1,000 for each serious violation as defined under N.J.A.C. 7:14-8.2; and
2. Not less than \$5,000 for each violation that causes a violator to be, or continue to be, a significant noncomplier as defined under N.J.A.C. 7:14-8.2.

(b) Each violation of any provision of the Water Pollution Control Act or any rule, pretreatment standard, effluent limitation, administrative order or permit issued by the Department, shall constitute an additional, separate and distinct violation. In addition, the unpermitted discharge of each separate pollutant shall constitute an additional, separate and distinct violation.

(c) Each day during which a violation as set forth in (b) above continues shall constitute an additional, separate and distinct violation.

(d) Unless the Department assesses a civil administrative penalty as set forth in N.J.A.C. 7:14-8.6 through 7:14-8.12, the Department may assess a civil administrative penalty for violations described in this section as described in (e) below.

(e) To assess a civil administrative penalty pursuant to this section, the Department shall:

1. Identify the penalty range within the matrix in (f) below by:
 - i. Determining the seriousness of the violation pursuant to (g) below; and
 - ii. Determining the conduct of the violator pursuant to (h) below; and

2. Assess the penalty at the midpoint of the range within the matrix in (f) below, unless adjusted pursuant to (i) below.

(f) The matrix of ranges of penalties is as follows:

(d) The Department may assess a civil administrative penalty in accordance with (c) above at any time. The assessment shall be based on the Department's evaluation of the delegated local agency's pretreatment program requirements. Furthermore, the Department may require a delegated local agency to adequately respond to findings based on an inspection conducted by the Department, the Department's review of the delegated local agency's 40 CFR Part 403 annual report, or the IPP on-site audit conducted by the Department.

(e) The Department may adjust the amount determined pursuant to (c) above to assess a civil administrative penalty from the midpoint of the range to an amount not greater than the maximum amount nor less than the minimum amount in the range on the basis of the following factors:

1. The compliance history of the violator;
2. The nature, timing and effectiveness of any measures taken by the violator to prevent future similar violations;
3. Any unusual or extraordinary costs or impacts directly or indirectly imposed on the public or the environment as a result of the violation; and/or
4. Other specific circumstances of the violator or violation.

(f) When the Department determines that the violator has gained an economic benefit from a violation, the Department may, in addition to any other civil administrative penalty assessed pursuant to this subchapter, include as part of a civil administrative penalty, under (c) above, the economic benefit (in dollars) which the violator has realized as a result of not complying, or by delaying compliance.

(g) If the Department determines that a delegated local agency has failed to assess mandatory minimum penalties in accordance with this subchapter or the Water Pollution Control Act, it shall take enforcement action against the delegated local agency, including, but not limited to, issuance of a notice of violation, issuance of an order, assessment of penalties and injunctive relief to compel compliance.

New Rule, R.1997 d.106, effective May 5, 1997.
 See: 28 N.J.R. 720(a), 28 N.J.R. 2779(a), 28 N.J.R. 3040(a), 28 N.J.R. 3494(a), 28 N.J.R. 4697(a), 29 N.J.R. 1691(c).
 Amended by R.1999 d.32, effective January 19, 1999.
 See: 30 N.J.R. 1356(a), 31 N.J.R. 157(a).
 In (c)3, rewrote iv; and added (g).

7:14-8.18 Severability

If any provision of this subchapter or the application thereof to any person or circumstances is held invalid, such invalidity shall not affect other provisions or applications, and to this end, the provisions of the subchapter are declared to be severable.

New Rule, R.1989 d.282, effective June 5, 1989.

See: 21 N.J.R. 373(a), 21 N.J.R. 1530(a).
 Amended by R.1991 d.378, effective August 5, 1991.
 See: 23 N.J.R. 1089(a), 23 N.J.R. 2366(a).
 Section recodified from 8.14.
 Recodified from 7:14-8.16 by R.1997 d.106, effective May 5, 1997.
 See: 28 N.J.R. 720(a), 28 N.J.R. 2779(a), 28 N.J.R. 3040(a), 28 N.J.R. 3494(a), 28 N.J.R. 4697(a), 29 N.J.R. 1691(c).

Case Notes

Penalty found appropriate for failure to provide self-monitoring reports, failure to construct treatment works and continued excessive discharge of pollutants. *Lentine Aggregates v. Dept. of Environmental Protection*, 4 N.J.A.R. 117 (1981), affirmed per curiam Dkt. No. A-3424-80 (App.Div.1982).

APPENDIX A

DEP LABORATORY METHODS

Method No. 010: pH (Electrometric)

Method No. 012: Total Residue

Method No. 013: Volatile and Ash Content of Total Residue

Method No. 032: Phenols

Method No. 036: Oil and grease

Method No. 100: Metals

pH (ELECTROMETRIC)

N.J. SLUDGE METHOD NO. DEP 010

1.0 Scope and Application

1.1 This method is applicable to the determination of pH in municipal and industrial sludges.

2.0 Summary of Method

2.1 A representative sample of sludge is thoroughly mixed and analyzed for pH electrometrically using either a glass electrode in combination with a reference electrode or a combination electrode.

2.2 The calibration of the pH electrode meter system is adjusted and checked with buffer solutions.

3.0 Sample Handling and Preservation

3.1 Upon collection, samples shall be refrigerated or iced at 4°C.

4.0 Limitations

4.1 Sodium error at pH levels greater than 10 can be reduced or eliminated by using a "low sodium error" electrode or applying a correction factor from a table or graph provided by the pH meter manufacturer.

4.2 Coatings of oil material or particulate matter can impair electrode response. These coatings can usually be removed by gentle wiping or detergent washing, followed by distilled water rinsing. An additional treatment with dilute hydrochloric acid (1 ml concentrated hydrochloric acid diluted to 10 ml with water) may be necessary to remove any remaining film.

NOTE 1: It may be necessary to centrifuge an oily sludge to obtain an aqueous phase for true pH determination.

4.3 Temperature effects on the electrometric measurement of pH arise from two sources. The first is caused by the change in electrode output at various temperatures. This interference can be controlled with instruments having temperature compensation or by calibrating the electrode-instrument system at the temperature of the samples. The second source is the change of pH inherent in the sample at various temperatures. This error is sample dependent and cannot be controlled; it should therefore be noted by reporting both the pH and temperature at the time of analysis.

5.0 Safety

5.1 The toxicity or carcinogenicity of each reagent used in this method has not been precisely defined; however, each chemical compound should be treated as a potential health hazard. From this viewpoint, exposure to these chemicals must be reduced to the lowest possible level by whatever means available. The laboratory should maintain a current awareness file of OSHA rules regarding the safe handling of the chemicals specified in this method. A reference file of Material Safety Data Sheets should be made available to all personnel involved in the chemical analysis.

6.0 Apparatus

6.1 pH Meter, laboratory or field model, with an accuracy of ± 0.05 unit. A wide variety of instruments are commercially available with various specifications and optional equipment.

6.2 Glass pH electrode.

6.3 Reference electrode—a fiber junction, calomel, silver-silver chloride or other electrode of constant potential may be used. (Do not use gel filled electrodes).

6.4 Glass combination electrode.

6.5 Magnetic stirrer and TFE coated stirring bar.

6.6 Thermometer with at least one degree calibrations or less.

NOTE 2: Temperature compensator may be used instead of a thermometer.

6.7 Dispersion Device, homogenizer, blender, or other apparatus capable of disintegrating large particles.

7.0 Reagents

7.1 Secondary standard buffers may be prepared from NBS salts or purchased as a solution from commercial vendors. Use of these commercially available solutions, that have been validated by comparison to NBS standards, are recommended for routine use.

8.0 Calibration

8.1 At a minimum, each instrument must be calibrated at pH 7.0 before each use and after each set of 10 samples. The accuracy of the system must be checked and recorded daily at approximately pH 4 and 9 or 10 with appropriate certified buffers. The three values must agree within 0.05 pH units of the assigned values.

8.1.1 If the values do not agree within 0.05 pH units, correct the problem before proceeding.

9.0 Procedure

9.1 Dilute, if required, with distilled water to achieve fluidity and/or to dissolve any inorganic buffer salts that may be present.

9.2 Disperse sample, if necessary, with a homogenizer or blender to disintegrate large particles.

9.3 Calibrate the meter and electrode system as described in Section 8.

9.4 Bring the sample temperature within 2°C of the buffer solution.

9.5 Rinse or gently wipe the electrodes with distilled or deionized water after each sample or buffer and gently blot them with a clean dry tissue. Immerse them into the sample beaker and stir gently at a constant rate to provide homogeneity and suspension of solids. Note and record sample pH to the nearest 0.1 unit and temperature to the nearest degree.

10.0 Precision and Accuracy—No data are available.

11.0 References

11.1 Methods for Chemical Analysis of Water and Wastes, U.S. Environmental Protection Agency, EPA 600/4-79-020, March, 1979.

TOTAL RESIDUE

N.J. SLUDGE METHOD NO. DEP 012

1.0 Scope and Application

1.1 This method is designed to measure the residue content of municipal and industrial sludges over a range of 1-75% W/W.

remaining solids are weighed and calculated as % W/W total residue of the original sample.

2.0 Summary of the Method

3.0 Sample Handling and Preservation

2.1 A representative portion of the sample is weighed and dried to constant weight in an oven at $104 \pm 1^{\circ}\text{C}$. The

3.1 Upon collection, samples shall be placed in a wide mouth, air tight, polyethylene or glass container and refrigerated or iced to 4°C.

4.0 Limitations

4.1 Rapid weighing of the sample, before and after drying, is essential to obtain accurate results.

5.0 Safety

5.1 The drying oven should be placed in a hood or supplied with a vent to remove noxious odors.

6.0 Apparatus

6.1 Pan balance, electronic, capable of weighing to \pm 0.01 gram.

6.2 Weighing dishes, aluminum pan, porcelain dish or equivalent.

Note 1: Use a porcelain dish if proceeding to N.J. Sludge Method No. DEP 013 or for highly alkaline samples.

6.3 Oven, mechanical or gravity convection capable of being regulated at $104 \pm 1^\circ\text{C}$, or equivalent.

6.4 Steam bath (optional).

6.5 Desiccator, with indicating desiccant.

7.0 Reagents—none.

8.0 Procedure

8.1 Tare the weighing dish, using a pan balance, to the nearest 0.01 gram and record as W1.

Note 2: If used, two aluminum pans should be seated together to provide a more rigid support for the sample.

8.2 Shake the covered sample container vigorously, disperse sample, if necessary, with a homogenizer or blender to disintegrate large particles.

8.3 Immediately, transfer a mixed sample aliquot to the dish such that the final residue weight is at least 1 gram and will provide adequate drying in 16–24 hours.

8.4 Reweigh the dish to the nearest 0.01 gram and record the weight as W2.

Note 3: Rapid transfer and weighing is essential to prevent loss of moisture during this step.

8.5 Transfer the dish containing the sample to a convection oven, operating at $104 \pm 1^\circ\text{C}$ and dry the contents to constant weight.

Note 4: A steam bath may be used to reduce the sample volume provided the sample is subsequently dried in the convection oven at 104°C for at least an hour and then brought to constant weight as specified above.

8.6 Remove the dish from the oven and place in a desiccator until cool. Reweigh to the nearest 0.01 gram and record weight as W3.

Note 5: Rapid weighing is essential to prevent the adsorption of moisture from the air.

Note 6: If volatile residue or ash residue analysis is to be performed on the sample, place the weighed sample in a desiccator and proceed directly with N.J. Sludge Method No. DEP 013.

9.0 Calculations

9.1 To determine the percent total residue by weight in the sample, use the following equation:

$$\% \text{ W/W total residue} = \frac{W3-W1}{W2-W1} \times 100$$

Where:

W1= weight of the original empty dish, in grams (see 8.1);

W2= weight of the original dish plus the sample, in grams (see 8.4);
and,

W3= weight of the original dish plus the sample residue, in grams (see 8.6).

10.0 Precision and Accuracy—No data are available.

11.0 References

11.1 Methods for Chemical Analysis of Water and Wastes, U.S. Environmental Protection Agency, EPA 600/4-79-020, March 1979.

VOLATILE AND ASH CONTENT OF TOTAL RESIDUE

N.J. SLUDGE METHOD NO. DEP 013

1.0 Scope and Application

1.1 This method is applicable to sludge and provides an approximation of the organic material contained in municipal and industrial sludge over a range of 1–75% W/W. It is used in conjunction with the procedure for the determination of Total Residue, N.J. Sludge Method No. DEP 012.

2.0 Summary of the Method

2.1 The residue from N.J. Sludge Method No. DEP 012, is ignited at 550°C in a muffle furnace. The loss in weight on ignition is reported as volatiles and the resulting solids are reported as ash.

3.0 Sample Handling and Preservation—See N.J. Sludge Method No. DEP 012.

4.0 Limitations

4.1 The method is empirical and approximates the organic content of the sludge due to the volatilization of organic matter. Mineral salts may decompose and give high results for organic volatiles.

5.0 Safety

5.1 The muffle furnace and drying ovens should be placed in a hood or supplied with a vent to remove noxious odors.

Note 1: Sludges containing relatively large amounts of nonvolatile hydrocarbons may present a potential hazard when placed in a muffle furnace at 550°C. These samples may be placed in a cold muffle furnace and brought up to 550°C slowly to avoid spontaneous ignition.

6.0 Apparatus

6.1 Muffle furnace, capable of being regulated at 550 ± 50°C.

7.0 Reagents—none.

8.0 Procedure

8.1 Place the weighed residue and dish from N.J. Sludge Method No. DEP 012, in a muffle furnace preheated to 550 ± 50°C.

Note 2: Do not use an aluminum pan for this procedure.

8.2 Ignite the sample for 60 minutes ± 5 minutes at 550 ± 50°C.

8.3 Remove the sample from the furnace with crucible tongs and after allowing the pan to cool partially in the air, place in a desiccator for at least one hour.

8.4 Reweigh the dish to ± 0.01 gram and record the weight as W4.

Note 3: If subsequent analyses are to be performed on the resultant residue, store the residue in a desiccator.

9.0 Calculations

9.1 To determine the volatile content of the residue, use the following equation:

$$\% \text{ W/W Volatile residue} = \frac{(W3-W4)}{W3-W1} \times 100$$

Where:

W1 = weight of the original dish, in grams (determined in DEP 012, 8.1);

W3 = weight of the original dish plus the sample residue, in grams (determined in DEP 012, 8.6); and,

W4 = weight of the original dish plus the ignited sample, in grams (determined in DEP 013, 8.4).

9.2 To determine the ash content of the residue, use the following equation:

$$\% \text{ W/W Ash residue} = \frac{W4-W1}{W3-W1} \times 100$$

Where:

W1 = weight of the original dish, in grams (determined in DEP 012, 8.1);

W3 = weight of the original dish plus the sample residue, in grams (determined in DEP 012, 8.6); and,

W4 = weight of the original dish plus the ignited sample, in grams (see DEP 013, 8.4).

10.0 Precision and Accuracy—No data are available.

11.0 References

11.1 Standard Methods for the Examination of Water and Wastewater, American Public Health Association, 14th ed., New York, 1975.

PHENOLS

N.J. SLUDGE METHOD NO. DEP 032

1.1 Scope and Application

1.1 This method is designed to determine the amount of phenolic compounds in municipal and industrial sludges.

1.1.1 The range of the method can be increased, if necessary, either by taking a smaller sample in step 9.2.3 or by taking a smaller aliquot in step 9.5.1.

1.1.2 The range of the method can be lowered, if necessary, by increasing the sample size taken in step 9.2.3.

2.0 Summary of Method

2.1 A representative portion of the sludge sample is mechanically dispersed in water to aid in solubilizing the phenolics, the pH is adjusted to pH 12.0–12.5 with sodium hydroxide. The alkaline sample is made to a known volume with water. A portion of the sample is filtered to remove insolubles. The filtrate is extracted with "Freon" †; 113 to remove interferences. The extracted sample is heated to remove the extractant, cooled to room temperature and then adjusted to pH 3 with phosphoric acid. A known portion of the acidic solution, after treatment with copper sulfate solution, is distilled to remove steam-distillable phenolics from the sample matrix. The steam-distillate is reacted with 4-aminoantipyrine at pH 10.0 ± 0.2 in the presence of potassium ferricyanide to form a reddish-brown colored antipyrine dye. The absorbance of the aqueous dye solution is measured directly at 510 nm. The concentration of phenolic compounds, as phenol (C₆H₅OH), in the sample is expressed in terms of mg/kg on the "dry weight" basis.

† Registered U.S. Patent Office

3.0 Sample Handling and Preservation

3.1 Upon collection, samples shall be placed in a wide mouth polyethylene or glass container and refrigerated or iced to 4°C.

4.0 Limitations

4.1 Addition of sodium hydroxide to the sample causes heavy metals to precipitate. If this precipitate is not removed, an emulsion forms during the "Freon" 113 extraction step which causes an inefficient separation of the two phases. Filtration prior to extraction removes the precipitate and the extraction step proceeds without difficulty as little or no emulsion is formed.

4.2 The "Freon" 113 extraction step is necessary to eliminate substances which steam distill over with the phenolics and cause turbidity which interferes with the photometric determination. The "Freon" 113 extraction step normally eliminates the need for redistillation to remove turbid materials as required in the referenced methods (12.1, 12.2 and 12.3).

4.3 Phosphoric acid and copper sulfate are added after extraction and prior to distillation to eliminate interference due to hydrogen sulfide and sulfur dioxide. The use of CuSO_4 during the distillation of an acidic sample permits the formation of cupric sulfide without subsequent decomposition to H_2S . The acid solution also prevents the precipitation of cupric hydroxide which acts as an oxidizing agent toward phenols.

4.4 The phenols are distilled at a nearly constant rate from the non-volatile impurities. The rate of volatilization of the phenols is gradual, so that the volume of the distillate must equal that of the sample being distilled. It is for the above reason that the distillation is carried out in two steps.

4.5 The term "phenolics" as used in this method includes those hydroxy derivatives of benzene and its condensed nuclei which can be determined by the specified conditions of this method. Certain para-substituted phenols are excluded from the determination as they do not react with the colorimetric reagent. Other phenols may also be excluded if they (1) do not form water soluble phenolates at pH 12 and are extractable by "Freon" 113 and (2) do not steam distill during the distillation step.

5.0 Safety

5.1 The toxicity or carcinogenicity of each reagent used in this method has not been precisely defined; however, each chemical compound should be treated as a potential health hazard. From this viewpoint, exposure to these chemicals must be reduced to the lowest possible level by whatever means available. The laboratory is responsible for maintaining a current awareness file of OSHA rule regarding the safe handling of the chemicals specified in this method. A reference file of Material Data Handling Sheets should be made available to all personnel involved in the chemical analysis.

6.0 Apparatus

6.1 Pan balance, capable of weighing to ± 0.1 gram.

6.2 Tekmar Tissumizer homogenizer, or equivalent, consisting of:

Tissumizer motor	# SDT-1810
Tissumizer shaft and generator	# SDT-182EN
Thyristor regulator	# TR-5T
Stand	# R-1821

NOTE 1: Blenders may not be an equivalent substitute.

6.3 Magnetic stirrer and TFE coated stirring bar.

6.4 pH Meter, laboratory or field model, with an accuracy of ± 0.05 unit. A wide variety of instruments are commercially available with various specifications and optional equipment.

6.5 Glass pH electrode.

6.6 Reference electrode—a fiber junction, calomel, silver-silver chloride or other electrode of constant potential may be used. (Do not use gel filled electrodes).

6.7 Glass combination electrode.

6.8 Filter, funnel, Buchner.

6.9 Filter discs, glass fiber, 7.0 cm, Whatman 943AH grade, or equivalent.

6.10 Separatory funnel, 1-liter capacity with TFE stopcock, Lab-Glass Co., Cat. No. LG-8371T-110, or equivalent.

6.11 Hotplate.

6.12 Ice-water bath.

6.13 1-liter distillation apparatus as shown in figure 1. Fisher Scientific Co., Cat. No. 9-126B, or equivalent.

6.14 Heating mantle, 1000 mL size, Glass-Col, or equivalent.

6.15 Retaining pan, stainless-steel mixing bowl, 3 qt. capacity.

6.16 Cenco-Lerner Lab-Jack, or equivalent.

6.17 500-mL volumetric flask, Class A, MCA type, marked at the 450 mL level.

6.18 Spectrophotometer, with 1.0 cm absorption cells.

7.0 Reagents

7.1 Sodium hydroxide (NaOH), 50% solution, reagent. Fisher Scientific Co., Cat. No. So-S-254, or equivalent.

7.2 "Freon" 113 ("F-113"; 1,1,2-trichloro-1,2,2-trifluoroethane).

NOTE 2: 250 mL of the solvent should leave no measureable residue on evaporation; distill if necessary.

7.3 Phosphoric acid (H₃PO₄), concentrated, reagent grade.

7.4 Copper sulfate (CuSO₄) solution.

Dissolve 100 g of reagent grade copper sulfate (CuSO₄·5H₂O) in reagent water and dilute to 1 liter volume. Store in glass container.

7.5 Ammonium chloride (NH₄Cl) solution, 2%.

Dissolve 20 g of reagent grade ammonium chloride in reagent water and dilute to 1 liter volume. Store in glass container.

7.6 Ammonium hydroxide (NH₄OH) solution, concentrated, reagent grade.

7.7 4-Aminoantipyrine solution, 2%. Prepare fresh daily.

Dissolve 2.0 g of 4-aminoantipyrine crystals in reagent water and dilute to 100 ml volume. Store in glass container.

7.8 Potassium ferricyanide (K₃Fe(CN)₆) solution, 8%. Prepare fresh weekly.

Dissolve 8.0 g of reagent grade potassium ferricyanide in reagent water and dilute to 100 ml volume. Store in glass container.

7.9 Phenol (C₆H₅OH), reagent grade.

7.10 Phenol Stock Solution. Prepare fresh monthly and store at 4°C in a low actinic bottle. (1.0 mL = 1.0 mg).

Weigh out 1.000 g (± 0.001 g) of reagent grade phenol crystals and transfer quantitatively to a clean 1-liter volumetric flask which contains about 800 mL of reagent water using reagent water to aid in the transfer. Make the flask to volume with reagent water and mix the contents thoroughly. May be kept for 3 days in 4°C refrigerator.

NOTE 3: CAUTION—Use extreme caution in handling reagent grade (100%) phenol as it is very caustic. Wash off spills with copious amounts of cold water. Wear appropriate gloves and eye protection when handling the crystals.

7.11 Phenol Standard Solution. Prepare fresh on day of use (1.0 mL = 0.10 mg).

Transfer a 25.0 mL (pipet) aliquot of the Phenol Stock Solution (1.0 mL = 1.0 mg) to a clean 250-mL volumetric flask which contains about 100 mL of reagent water. Make the flask to volume with reagent water and mix the contents thoroughly. Use within 2 hours after preparation.

7.12 Reagent water, distilled or deionized.

7.13 Boiling stones, Hengar granule.

7.14 "Chromerge", or equivalent—chromic acid dissolved in concentrated H₂SO₄.

NOTE 4: CAUTION—Use care in preparation and handling. Wear appropriate gloves and eye protection.

8.0 Calibration

8.1 Spectrophotometer Calibration

8.1.1 Prepare a series of 100 mL phenol standards in clean, dry 150-mL beakers according to the following schedule:

Phenol Standard Solution (1.0 mL = 0.10 mg phenol)	Reagent Water Phenol	
	mL	mg
0.0	100.0	0.00
1.0	99.0	0.10
2.0	98.0	0.20
3.0	97.0	0.30
4.0	96.0	0.40
5.0	95.0	0.50
7.0	93.0	0.70
10.0	90.0	1.00

NOTE 5: All solutions must be at room temperature.

NOTE 6: Use an automatic laboratory grade 100-mL buret to add the water to the beaker and a 10-mL buret to add the phenol standard to the water.

8.1.2 Develop and measure the color, immediately and without delay, in the series of standards according to the procedure given in steps 9.5.2–9.5.8.

8.1.3 Calculate the factor (F) according to the following directions.

8.1.3.1 Determine the individual factor (f) for each standard in the series to the nearest 0.1 unit using 1.0 cm cells according to the following formula:

$$\frac{C}{A} \times 1000 = f$$

Where: C = mg of phenol present in the standard solution.
A = absorbance of standard solution in a 1.0 cm cell at 510 nm.

8.1.3.2 Determine the average factor for the seven individual standard solutions and record it as the factor (F) to the nearest whole number for the 1.0 cm cell.

8.1.3.3 A plot of absorbance vs. mg phenol (per 100 mL volume) on rectilinear coordinate graph paper should yield a straight line which passes through the origin.

9.0 Procedure

9.1 Determine % W/W total residue, NJ Sludge Method No. DEP 012.

9.2 Sample Preparation

9.2.1 Shake the covered sample container vigorously several times to ensure mixing.

9.2.1.1 Break up large particles with a spatula and remix.

9.2.2 Tare a clean, dry 250-mL beaker on a pan balance to the nearest 0.1 gram, record as W1.

9.2.3 Transfer, with a metal spatula 18–22 g of the well-mixed sample, (be sure to pick up the sample from at least two different spots within the sample container), weighed to the nearest 0.1 g, to the beaker, record as W2.

9.2.4 Add about 150 mL of reagent water to the beaker.

9.2.5 Use the Tekmar homogenizer to disperse the sludge sample into the water. Homogenize for 1-minute, first at a low speed setting, with the bottom of the probe just off the beaker bottom. The speed setting may be increased to increase the efficiency of the dispersion as long as no sample spills from the beaker.

9.2.6 Turn off homogenizer and let any large undispersed particles settle for 1 minute.

9.2.7 Decant slowly the dispersed sample into a clean 1-liter beaker. Retain all large particles in the 250-mL beaker for further dispersion.

9.2.8 Repeat steps 9.2.4–9.2.7 as needed, to completely disperse the sample. Normally, this step will be repeated 4–5 times.

9.2.9 Quantitatively rinse all residue from the homogenizer probe into the beaker using several reagent water rinses. The homogenizer may be turned “on” for a fraction of a second several times to remove water from the probe. Do this while the probe is inserted in the empty beaker.

9.2.10 Add a magnetic stirring bar to the dispersed sample in the liter beaker, stir the contents and measure the sample pH (meter standardized with pH 7 buffer; use temperature compensation).

9.2.11 Add dropwise 50% NaOH solution to bring solution to pH 12.2–12.5. Heavy metal ions will form a precipitate.

9.2.12 Transfer the alkaline solution quantitatively to a 1-liter volumetric flask using reagent water to aid in the transfer and to make the flask to volume. Mix the contents thoroughly.

9.2.13 Let the solids formed settle for 5–10 minutes and then filter about 600 mL of the supernatant solution through a 7.0 cm glass fiber filter (on a 7.0 cm Buchner funnel) into a 1-liter suction flask. Do not wash the filter cake. Use a dry funnel and suction flask for this step. Discard the filter residue.

9.3 Sample Extraction

9.3.1 Transfer the filtrate to a dry 1-liter separatory funnel.

9.3.2 Add 50 mL (graduated cylinder) of “Freon” 113, stopper the funnel and shake the contents vigorously for 1 minute to extract interferences into the “Freon” 113. Carry out extractions in front of well-ventilated laboratory hood. The separatory funnel stem must be dry before use. Vent the funnel, after the extraction, through the top stopper, not through the stopcock. Keep the emulsion in the funnel.

9.3.3 Swirl the funnel contents gently, let the “Freon” 113 settle for about 1–2 minutes and then drain the bottom “Freon” 113 layer to a waste solvent jar.

9.3.4 Repeat steps 9.3.2 and 9.3.3 three times more to extract the solution with a total of 200 mL of “Freon” 113.

9.3.5 Drain the extracted alkaline water layer back to a clean, dry 800-mL beaker.

9.3.6 Heat the solution (in a hood) to 60°C (thermometer) with occasional stirring to remove residual “Freon” 113. Stir the hot solution on magnetic stirrer at moderate rate for 1 minute to completely remove all of the “Freon” 113.

9.3.7 Cool the solution to room temperature (thermometer in an ice-water bath).

9.3.8 Measure out 500 mL (graduated cylinder) of the above solution to an 800-mL beaker and adjust the solution to pH 3.0–3.1 by the dropwise addition of concentrated phosphoric (H_3PO_4) acid while stirring the solution with a magnetic stirrer.

9.3.9 Proceed now directly to step 9.4, without delay.

9.4 Sample Distillation

NOTE 7: IMPORTANT, if a white residue (probably a copper salt) remains on the interior of the distillation flask after the normal cleaning treatment, it can be removed by rinsing the flask with warm 1+1 nitric acid (caution) followed by rinsing with reagent water to remove the residue and the acid.

9.4.1 Transfer, without rinsing the beaker, the extracted, acidified solution to a clean phenol distillation apparatus (see Figure 1).

9.4.2 Add 5 mL pipet of copper sulfate (CuSO_4) solution, add 12–15 boiling stones and then stopper the retort flask.

NOTE 8: Do not use glass beads as they cause excessive bumping.

9.4.3 Place a clean, dry 500-mL special volumetric flask under the condenser and turn on the positioned heating

mantle. Be sure cooling water is flowing through the condenser.

9.4.4 Let the solution come to a full boil, distill 450 mL of the sample into the volumetric flask and then stop the distillation at this point by turning off the heating mantle and lowering it from the distillation flask. Use the 450 mL graduation mark on the special volumetric flask to determine the distillate volume. The heating mantle is connected directly into a 110 volt line, not into a Variac, in order to reduce the time of distillation.

9.4.5 Remove carefully, when boiling ceases, the stopper from the retort flask and add 50 mL (graduated cylinder) of reagent water to the flask.

9.4.6 Restopper the apparatus, reposition the heating mantle and reheat the solution to a boil again. Continue the distillation until a total of 500 mL of distillate has been collected in the volumetric flask.

9.4.7 Just as 500 mL volume is collected, turn off the heating mantle and lower it from the retort flask to stop the distillation. The distillate should be clear (no turbidity or oil droplets), essentially odorless and essentially colorless.

9.4.8 Mix thoroughly the contents of the stoppered volumetric flask by shaking and then proceed directly to step 9.5 without delay.

9.5 Colorimetric Procedure-Direct Photometric

9.5.1 Transfer 100 mL (pipet) of the mixed distillate (from step 9.4.8) to a clean dry 150-mL beaker. Prepare a blank from 100 mL (pipet) of reagent water and carry it through the same steps as the sample. If necessary, a smaller aliquot (pipet) of the sample distillate plus enough reagent water (pipet) to make a total volume of 100 mL is transferred to a 150-mL beaker.

9.5.2 Add 5.0 mL (pipet) of ammonium chloride (NH_4Cl) solution and mix with a clean glass stirring rod.

9.5.3 Calibrate the pH meter (combination electrode) with pH 7 buffer. Be sure to wash off buffer from the electrode with reagent water.

9.5.4 Measure pH of sample solution and adjust it to pH 10.0 ± 0.2 by dropwise addition of concentrated ammonium hydroxide (NH_4OH) solution (in a hood) from a medicine dropper while mixing the solution with the glass rod.

9.5.5 Remove pH electrode from the solution. Rinse off the electrode into a waste beaker, not into the sample solution.

9.5.6 Add 2.0 mL (pipet) of 4-aminoantipyrine solution (4-AAP) to the sample and mix promptly; followed immediately by 2.0 mL (pipet) of potassium ferricyanide solution ($\text{K}_3\text{Fe}(\text{CN})_6$) and again mixed immediately. Treat each sample (and BLANK) in the series with the two reagents, as above, before proceeding to the next in the series.

9.5.7 Let the solution stand for 15 minutes, after mixing, to develop the color completely.

9.5.8 Measure the absorbance (A) of the sample solution (vs. the BLANK set at 0.000 absorbance) in a 1.0 cm absorption cell with the spectrophotometer set at 510 nm wavelength. Rinse the cell 2 times with reagent water and 2 times with acetone between samples. Use vacuum to aspirate the sample, water and acetone from the cell.

10.0 Calculations

10.1 Determine the amount (mg/kg) of phenolics in the sample on a dry weight basis, use the following equation:

$$\text{mg/kg phenolics} = \frac{A(F)(100000)}{V(W2-W1)(\%S)}$$

Where:

- A = absorbance of sample solution (see 9.5.8) in 1.0 cm cell;
- F = factor as determined (see 8.1.3.2);
- V = mL volume of distillate (see 9.5.1), usually 100 mL;
- W1 = weight of the original empty beaker, in grams (see 9.2.2);
- W2 = weight of the original empty beaker plus the sample, in grams (see 9.2.3); and
- %S = percent W/W total residue of sample (see 9.1) as determined by N.J. Sludge Method No. DEP 012.

Report all results to nearest mg/kg.

10.1.1 If the absorbance in the 1.0 cm cell in step 9.5.8 is less than 0.010A, then report the mg/kg value as "less than" the calculated value using 0.010A.

10.1.2 If the absorbance in the 1.0 cm cell in step 9.5.8 is greater than 1.000A, repeat steps 9.5.1-9.5.8 using a smaller aliquot of the distillate.

11.0 Precision and Accuracy—No data are available.

12.0 References

12.1 Methods for Chemical Analysis of Water and Wastes, U.S. Environmental Protection Agency, Cincinnati, 1974, pp. 241-242.

12.2 1974 Annual Book of ASTM Standards (Part 31), American Society for Testing and Materials, Philadelphia, 1974, Method D 1783-70 (Reapproved 1974).

12.3 Standard Methods for the Examination of Water and Wastewater, American Public Health Association, 14th ed., New York, 1975, Method 510.

Figure 1

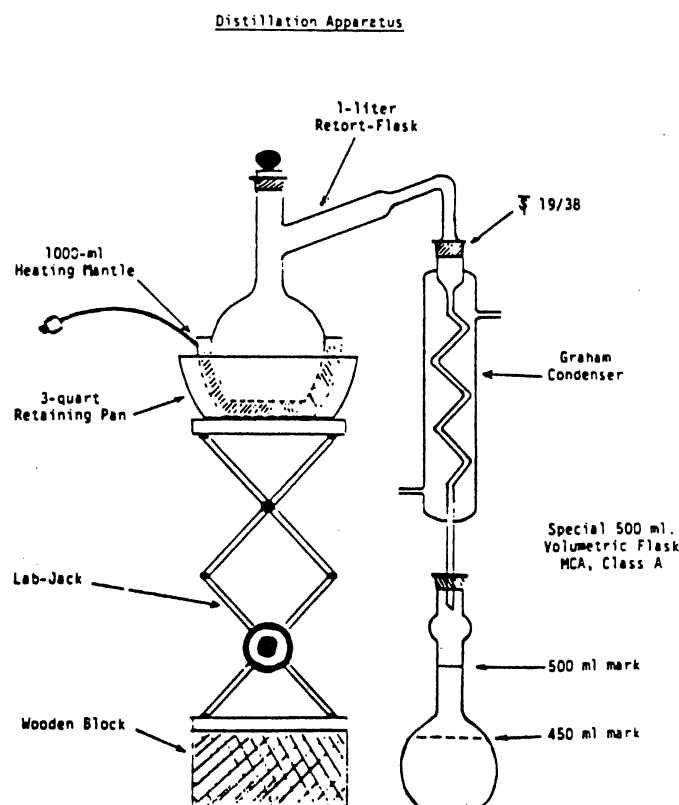

OIL AND GREASE

N.J. SLUDGE METHOD DEP 036

1.0 Scope and Application

1.1 This method is designed to determine the amount of oil and grease in municipal and industrial sludges in the range of 0-10% W/W oil and grease.

2.0 Summary of Method

2.1 This method defines two extraction procedures, one applicable to all sludges and one which may be used for sludge samples with a low percent total residue.

2.1.1 For all sludge samples, provided the detection limit of 0.5% can be achieved, a representative portion of the sludge sample is manually dispersed in a limited volume of water and then acidified with concentrated hydrochloric acid. The acidified sample slurry is dehydrated with the addition of magnesium sulfate monohydrate. After solidification, the dry sample is ground to a powder. Oil and grease is extracted from the powdered sample in a soxhlet extraction apparatus, using "Freon" † 113 as the extractant.

2.1.2 For sludge samples containing less than ten percent W/W total residue, the sample may be manually dispersed and acidified with concentrated hydrochloric acid. The oil

and grease is extracted from the sample in a separatory funnel using "Freon" 113 as the extractant.

2.2 The "Freon" 113 is removed by distillation and the amount of residual extracted oil and grease, after drying, is determined gravimetrically. Results are reported as % W/W oil and grease on the dry 100% solids basis.

† Registered U.S. Patent Office.

3.0 Sample Handling and Preservation

3.1 Upon collection, samples shall be refrigerated or iced at 4°C.

4.0 Limitations

4.1 Any filterable "Freon" 113 soluble substances, such as elemental sulfur and certain organic dyes and nitrobenzenes, will be extracted and calculated as oil and grease.

5.0 Safety

5.1 The toxicity or carcinogenicity of each reagent used in this method has not been precisely defined; however, each chemical compound should be treated as a potential health hazard. From this viewpoint, exposure to these chemicals must be reduced to the lowest possible level by whatever means available. The laboratory is responsible for maintaining a current awareness file of OSHA rule regarding the

safe handling of the chemicals specified in this method. A reference file of Material Safety Data Sheets should be made available to all personnel involved in the chemical analysis.

6.0 Apparatus

- 6.1 Pan balance, capable of weighing to ± 0.1 gram.
- 6.2 Glass stirring rod, heavy duty.
- 6.3 Boiling stones, Hengar granule.
- 6.4 Desiccator, with indicating silica-gel or calcium sulfate desiccant.
- 6.5 Finger cots, rubber, large, Fisher Scientific Co., Cat. No. 10-001C, or equivalent.
- 6.6 Balance, analytical, capable of weighing to ± 0.1 mg.
- 6.7 Hot water/steam bath.
- 6.8 Connecting tube, condenser, and solvent receiver.
- 6.9 For soxhlet extraction only (see 8.2).
 - 6.9.1 Mortar and pestle, glass, 16 oz. capacity. Do not use porcelain as it is difficult to clean.
 - 6.9.2 Soxhlet extraction assembly, consisting of:

Flask, 250 ml capacity, flat-bottom, with 24/40 joint; Fisher Scientific Co., Cat. No. 09-559B, or equivalent;

Extraction tube, with 55/50 joint, Fisher Scientific Co., Cat. No. 09-558C, or equivalent;

Condenser, Allihn-type with 55/50 joint, Fisher Scientific Co., Cat. No. 09-557C, or equivalent; and

Soxhlet cellulose extraction thimble, 43 mm diameter x 123 mm long, mfged. by Whatman, or equivalent.
 - 6.9.3 Glasswool, washed with "Freon" 113.
 - 6.9.4 Heating mantle, designed for flat bottom flask, 250-ml size.
 - 6.9.5 Variable autotransformer, 120V output with 0-100 scale.
 - 6.9.6 Forceps, metal, approx. 10 inch length.
- 6.10 For separatory funnel extraction only (see 8.3).
 - 6.10.1 Separatory funnel, 50 ml with TFE stopcock.
 - 6.10.2 Drying column-Chromatographic column, 19 mm ID, coarse frit filter disc.

6.10.3 Flask, 250 ml capacity, flat-bottom, with 24/40 joint; Fisher Scientific Co., Cat. No. 09-559B, or equivalent.

7.0 Reagents

- 7.1 Hydrochloric acid (HCl), concentrated.
- 7.2 Indicating pH paper for low pH measurement.
- 7.3 "Freon" 113 ("F-113"; 1,1,2-trichloro-1,2,2-trifluoroethane).

NOTE 1: 250 ml of the solvent should leave no measurable residue on evaporation; distill if necessary.

7.4 For soxhlet extraction only (see 8.2).

7.4.1 Magnesium sulfate monohydrate ($\text{MgSO}_4\text{H}_2\text{O}$).

Dry a thin layer of laboratory grade magnesium sulfate heptahydrate ($\text{MgSO}_4\cdot 7\text{H}_2\text{O}$), crystal, in an oven at 105-110°C for 48 hours.

NOTE 2: Stir and break up lumps frequently during the drying process.

NOTE 3: Caution, do not attempt to substitute magnesium sulfate, anhydrous, powder for the monohydrate as too much heat will be generated during the procedure and the resulting mass will be difficult to pulverize.

7.4.2 Reagent Water, distilled or deionized.

7.5 For separatory funnel extraction only (see 8.3).

7.5.1 Sodium sulfate-(ACS) Granular, anhydrous. Purify by heating at 400°C for 4 hours in a shallow tray.

8.0 Procedure

8.1 Determine % W/W total residue, N.J. Sludge Method No. DEP 012, if necessary.

8.2 Soxhlet extraction-applicable to all sludge samples, provided the required detection limit can be achieved.

8.2.1 Shake the covered sample container vigorously, disperse sample, if necessary, with a homogenizer or blender to disintegrate large particles.

8.2.2 Tare a clean, dry 250 ml beaker on a pan balance to the nearest 0.1 mg, record as W1.

8.2.3 Transfer, with a metal spatula 18-22 grams of the well-mixed sludge sample, (be sure to pick up the sample from at least two different spots within the sample container), weighed to the nearest 0.1 mg, to the beaker, record as W2.

8.2.4 Add 20 ml (graduated cylinder) of reagent water to the sample, if necessary, to fluidize.

8.2.5 Disperse the sample manually into the water, using the flat end of a clean, heavy glass stirring rod, with stirring and mixing to yield a uniform, lump-free slurry (do not homogenize). This step may require several minutes of effort to achieve the uniform finely divided slurry; do not use any additional water in this step.

8.2.6 Add concentrated hydrochloric acid (HCl), approximately one ml at a time, to the dispersed sample while stirring with the glass rod until the slurry is strongly acidic (pH 2 or less) as indicated by the pH paper. Stir the sample 10–15 seconds before testing for acidity.

8.2.7 Wait 10 minutes after the last HCl addition and recheck for acidity using the pH paper. If the sample is strongly acidic (pH 2 or less) proceed to step 8.2.8. If the sample is not strongly acidic, continue the HCl addition as in step 8.2.6 and repeat step 8.2.7 until the acidity holds for at least 10 minutes.

8.2.8 Reweigh the beaker (no stirring rod present) to the nearest 0.1 gram, record as M, determine the amount of total acidic slurry (TAS) that is present by difference from the tare weight (W1) of step 8.2.2 ($TAS = M - W1$).

8.2.9 Weigh out the magnesium sulfate monohydrate ($MgSO_4 \cdot H_2O$) that is at least equal to 1.3 times the total acid slurry weight found in step 8.2.8, ($grams\ MgSO_4 \cdot H_2O = TAS \times 1.3$).

8.2.10 Add slowly while stirring with the glass rod the $MgSO_4 \cdot H_2O$ to the acid slurry. The $MgSO_4 \cdot H_2O$ will dehydrate the sample slurry to form a solid sample that can be ground to a powder. The oil and grease will be dispersed in the solid sample and heat will be generated by the reaction.

8.2.11 Stir the sample with the glass rod to a smooth paste and, before the paste sets up, spread the paste evenly over the entire inside of the beaker surface to facilitate its subsequent removal after it solidifies. Keep the paste off the bottom of the beaker as much as possible to ease the removal of the solidified sample in step 8.2.13.

8.2.12 Let the sample stand for about $\frac{1}{2}$ hour so it may solidify and cool.

8.2.13 Transfer the solidified sample, using a metal spatula, to a clean glass mortar and grind to a uniform, free-flowing powder. Do not attempt to grind the entire sample at one time.

8.2.14 Transfer the entire powdered sample to a soxhlet cellulose extraction thimble (43 mm diameter X 123 mm long). Tap the thimble gently as it is filled to prevent the presence of voids in the powder. At this point, the thimble and sample can be placed in a clean labeled pint screwcap jar to hold overnight, if necessary.

8.2.15 Transfer one small boiling stone to a clean, dry 250 ml flat bottom extraction flask (24/40 joint) and place in a desiccator to condition for at least 1/2 hour.

8.2.16 Remove the flask from the desiccator, using finger cots, and rapidly weigh to the nearest 0.1 mg; record as W3, and set the flask aside.

8.2.17 Fill the remaining space in the sample-filled thimble with a loosely-packed wad of glasswool (washed with "Freon" 113) to prevent particles from flushing out of the thimble during extraction.

8.2.18 Gently slide the extraction thimble down the inside of the clean, dry extractor tube and assemble it to the condenser and to the tared extraction flask. Be sure good seal is obtained for the ungreased ground glass joint.

8.2.19 Seat the extraction flask in the heating mantle that is controlled by a variable transformer.

8.2.20 Turn on the water flow to the condenser; check for an adequate flow during the extraction procedure.

8.2.21 Slowly transfer about 225 ml (graduated cylinder) of "Freon" 113 to the apparatus by pouring it through the condenser top.

8.2.22 Turn on the heating mantle with the transformer (120 V output) to obtain a reflux rate of 1 cycle/3 minutes \pm 15 seconds, maintain reflux for 4 hours.

Note 4: The transformer setting should be noted for future use.

Note 5: The rate and time of extraction in the soxhlet apparatus must be exactly as directed because of the varying solubilities of different greases.

8.2.23 Turn off and remove the hot mantle from the extraction flask at the end of the 4 hour extraction period.

8.2.24 Remove the extraction flask from the apparatus and set aside; remove the thimble from the tube, using a clean, long metal forceps, and let the "Freon" 113 drain back into the tube; transfer the residual "Freon" 113 from the tube to the flask. Discard the thimble and extracted sample. Proceed to step 8.4.

8.3 Separatory funnel extraction-recommended for sludge samples with less than ten percent W/W total residue as determined in N.J. Sludge Method No. DEP 012.

8.3.1 Shake the covered sample container vigorously, disperse sample, if necessary, with a homogenizer or blender to disintegrate large particles.

8.3.2 Tare a clean, dry 250 ml beaker on a pan balance to the nearest 0.1 mg, record as W1.

8.3.3 Transfer approximately 100 grams of the well-mixed sludge sample to the 250 ml beaker, weigh to the nearest 0.1 mg, record as W2.

8.3.4 Add concentrated hydrochloric acid (HCl), approximately one ml at a time, to the dispersed sample while stirring with the glass rod until the slurry is strongly acidic (pH 2 or less) as indicated by the pH paper. Stir the sample 10–15 seconds before testing for acidity.

8.3.5 Wait 10 minutes after the last HCl addition and recheck for acidity using the pH paper. If the sample is strongly acidic (pH 2 or less) proceed to step 8.3.6. If the sample is not strongly acidic, continue the HCl addition as in step 8.3.4 and repeat step 8.3.5 until the acidity holds for at least 10 minutes.

8.3.6 Place a clean, dry 250 ml flat bottom extraction flask in a desiccator to condition for at least one hour.

8.3.7 Remove the flask from the desiccator, using finger cots, and rapidly weigh to the nearest 0.1 mg; record as W3, and set the flask aside.

8.3.8 Quantitatively transfer the acidified sample to a 500 ml separatory funnel with a TFE stopcock.

8.3.9 Add 50 ml of "Freon" 113 to the separatory funnel and extract the sample by shaking the funnel for two minutes with periodic venting to release excess pressure. Allow the organic layer to separate from the water phase for a minimum of ten minutes. If the emulsion interface between layers is more than one third the volume of the solvent layer, the analyst must employ mechanical techniques to complete the phase separation. The optimum technique depends upon the sample, but may include stirring, centrifugation, or other physical methods. Transfer the extract to an Erlenmeyer flask.

8.3.10 Add a second 50 ml volume of "Freon" 113 and repeat the extraction procedure a second time combining the extracts in the Erlenmeyer flask. Perform a third extraction in the same manner.

8.3.11 Pour the combined extract through a solvent-rinsed drying column containing about 10 cm of anhydrous sodium sulfate, and collect the extract in the tared 250 ml flat bottom extraction flask. Rinse the Erlenmeyer flask and column with 20 to 30 ml of "Freon" 113 to complete the quantitative transfer. Proceed to step 8.4.

8.4 Distill the "Freon" 113 from the flat bottom extraction flask in a $70 \pm 5^\circ\text{C}$ hot water bath. Clamp the extraction flask at a 45 degree angle and distill the "Freon" 113 into the solvent recycling apparatus.

Note 6: Carry out the distillation in a hood.

8.5 Place the extraction flask, free of "Freon" 113, on a boiling water/steam bath for 15 minutes. Again, clamping the flask at a 45 degree angle in a hood.

8.6 During the final 1 minute on the steam bath, draw air gently through the flask by means of applied vacuum, using 1/4' OD polyethylene tube which reaches to within 1' from the bottom of the extraction flask. The vacuum removes any heavy "Freon" 113 vapors which could cause high results to be reported if they were not drawn off and removed.

8.7 Wipe off the entire outside of the extraction flask with clean, dry paper towels to remove all traces of water.

8.8 Place the flask in a desiccator and let it cool for exactly 30 minutes.

Note 7: The length of time required for drying and cooling the extracted material cannot be varied. There may be a gradual increase in weight, presumably due to the absorption of oxygen or a gradual loss in weight due to volatilization, if the times are varied.

8.9 Remove from the desiccator, using finger cots, and rapidly weigh to the nearest 0.1 mg, record as W4.

9.0 Calculations

9.1 To determine the percent W/W oil and grease in the sample on a dry weight basis, use the following equation:

$$\% \text{ W/W oil and grease} = \frac{W4 - W3}{W2 - W1 (\%S)} \times 10,000$$

Where

W1 = weight of the original empty beaker, in grams (see 8.2.2 or 8.3.2);

W2 = weight of the original empty beaker plus the sample, in grams (see 8.2.3 or 8.3.3.);

W3 = weight of the empty flask, in grams (see 8.2.16 or 8.3.7);

W4 = weight of the empty flask plus the oil and grease extract, in grams (see 8.9); and

%S = percent W/W total residue of sample (see 8.1) as determined by N.J. Sludge Method No. DEP 012.

Report all results to the nearest 0.1%

10.0 Precision and Accuracy

10.1 The following data were obtained during the development of this method.

A composite sample (43.7% solids) was analyzed four times according to the soxhlet extraction procedure contained in this method. The following results were obtained:

Run	1	2	3	4	Avg.	STD. Dev.
% of oil and grease	1.0	1.0	0.8	1.1	1.0	0.13

10.2 The above data indicates that the method, as written, is reasonably precise when a large enough representative sample is taken for analysis. The relative standard deviation of the determination is $\pm 13\%$, for a single laboratory.

11.0 References

11.1 Standard Methods for the Examination of Water and Wastewater, American Public Health Association, 14th ed., New York, 1975, Method 502D.

METALS

N.J. SLUDGE METHOD NO. DEP 100

1.0 Scope and Application

1.1 This procedure is applicable to the preparation of sludge samples prior to the determination of metals by atomic absorption spectrometry. This procedure is applicable to both direct aspiration and furnace atomization of the following elemental priority pollutants: arsenic (As), cadmium (Cd), calcium (Ca), chromium (Cr), copper (Cu), lead (Pb), magnesium (Mg), nickel (Ni), potassium (K), and zinc (Zn).

2.0 Summary of Method

2.1 This method defines two digestion procedures, one applicable to all sludges and one which may be used for sludge samples with a low percentage total residue.

2.1.1 For all sludge samples, the sample is digested with nitric acid and hydrogen peroxide and analyzed using atomic absorption methods.

2.1.2 For sludge samples containing less than ten percent W/W total residue, the sample may be treated as an aqueous sample and analyzed using the U.S. EPA procedure for the determination of total metals by atomic absorption found in the Methods for Chemical Analysis of Water and Wastes U.S. EPA (EPA-900/4-79-020).

3.0 Sample Handling and Preservation

3.1 Samples should be maintained at 4°C.

4.0 Limitations

4.1 See Section 5.0 of the Metals-Atomic Absorption Method in the Methods for Chemical Analysis of Water and Wastes, U.S. EPA (EPA 600/4-79-020).

5.0 Safety

5.1 The toxicity or carcinogenicity of each reagent used in this method has not been precisely defined; however, each chemical compound should be treated as a potential health hazard. From this viewpoint, exposure to these chemicals must be reduced to the lowest possible level by whatever means available. The laboratory is responsible for maintaining a current awareness file of OSHA rules regarding the safe handling of the chemicals specified in this method. A reference file of Material Data Handling Sheets should be made available to all personnel involved in the chemical analysis.

6.0 Apparatus

6.1 See Section 6.0 of the Metals-Atomic Absorption Method in the Methods for Chemical Analysis of Water and Wastes, U.S. EPA (EPA 600/4-79-020).

7.0 Reagents

7.1 See Section 7.0 of the Metals-Atomic Absorption Method in the Methods for Chemical Analysis of Water and Wastes, U.S. EPA (EPA 600/4-79-020).

7.2 Hydrogen Peroxide (30%).

8.0 Procedure

8.1 Sludge Digestion—applicable to all sludge samples.

8.1.1 Weigh and transfer to a 125-mL conical beaker a representative, 1.0 gram aliquot of a pulverized sample that has been dried in accordance with N.J. Sludge Method No. DEP 012. Record the weight of the sample to the nearest mg and record as D.

8.1.2 Add 5 mL of 1:1 nitric acid to the beaker, and cover it with a watch glass. Heat the contents of the beaker gently so that a reflex action occurs. Continue heating until the volume of the contents is reduced to approximately 2 mL.

8.1.3 Allow the contents to cool, add 4 mL of concentrated HNO₃ and again heat at a gentle reflux until the volume is reduced to approximately 2 mL.

8.1.4 After the second reflux has been completed and the sample has cooled, add 2 mL of concentrated nitric acid, 2 mL of deionized distilled water, and 2 mL of 30% hydrogen peroxide.

8.1.5 Return the beaker to the hot plate for warming to start the peroxide reaction. The reaction is vigorous. Care must be taken to avoid losses with the start of effervescence.

8.1.6 Heat until the volume is reduced to approximately 3 mL.

8.1.7 Continue the addition of 30% hydrogen peroxide in 3 mL increments (do not add more than 3 increments) with warming until the effervescence is minimal or the general sample appearance is unchanged.

8.1.8 Wash any residue from the underside of the watch glass and walls of the beaker into the sample solution and dilute the contents of the beaker to approximately 10.0 mL with deionized distilled water. Filter the contents of the beaker into a 50-mL volumetric flask through Whatman No. 42 paper (or the equivalent). Wash the insoluble residues in the beakers three times with 5 mL portions of 1% nitric acid, and add the washings to the volumetric flasks through the filters.

8.1.9 Dilute the contents of the volumetric flasks to 50 mL with deionized distilled water and analyze by atomic absorption spectrometry as specified in the Section 9.0 of the Metals-Atomic Absorption Method in the Methods for Chemical Analysis of Water and Wastes, U.S. EPA (EPA-600/4-79-020). Record the metal concentration in S/ml.

8.2 Aqueous Sludge Digestion—if the percent W/W total residue as determined in N.J. Sludge Method No. DEP 012 is less than ten, the following procedure may be used.

8.2.2 Determine percent W/W total residue, N.J. Sludge Method No. DEP 012, if necessary.

8.2.3 Digest an amount of sludge that will give the equivalent of one (1) gram on a dry weight basis and analyze the sample using the method specified in Section 4.1.3 of the Metals-Atomic Absorption Method in the Methods for the Chemical Analysis of Water and Wastes, U.S. EPA (EPA 600/4-79-020).

NOTE 1: The appropriate conversion must be made to report the final result on a dry weight (W/W) basis.

9.0 Calculations

9.1 To determine the amount of metal present in the sample on a dry weight basis when using the procedure in section 8.1 of this method, use the following equation:

$$\text{mg metal/kg sample} = \frac{(A)(V)}{(D)}$$

Where: A = ug/mL of metal in digested sample (see 8.1.9);
V = final volume of processed sample in mL (see 8.1.8); and
D = Weight of dry sample in grams (see 8.1.1).

10.0 Precision and Accuracy

10.1 In an interlaboratory study, Reference 11.4, using a U.S. EPA reference sludge sample, the following data were obtained:

<u>Determination</u>	<u>Interlaboratory Study</u>				
	<u>EPA Reference Value</u>	<u>%</u>	<u>Number of Participants</u>	<u>Laboratory Average</u>	<u>Laboratory Standard Deviation</u>
1. ARSENIC	16.97		6	6.57	12.8
2. CADMIUM	20.77		13	18.5	2.95
3. CALCIUM	—		10	15300	5800
4. CHROMIUM	204		15	183	38
5. COPPER	1095		14	941	125
6. LEAD	519		14	516	83
7. MAGNESIUM	—		9	3620	2200
8. NICKEL	198		15	165	27
9. POTASSIUM	—		7	775	262
10. ZINC	1323		14	1190	185

11.0 References

11.1 Methods for the Chemical Analysis of Water and Wastes, U.S. EPA (EPA-600/4-79-020), March 1979.

11.2 Test Methods for the Evaluation of Solid Waste, Method 3050, USEPA SW-846, April 1984.

11.3 "Interim Methods for the Analysis of Elemental Priority Pollutants in Sludge", U.S. EPA, Cincinnati, 1978.

11.4 Adelman, H., Jenniss, S.W., and Katz, S.A., "Interlaboratory Analysis of Sewage Sludge", American Laboratory, December 1981.

ULTIMATE SLUDGE MANAGEMENT METHOD CODE:

1. Land Application at a NJPDES Permitted Site
2. State Approved Distribution Permit
3. Incineration
4. Ocean Disposal
5. Out of State
6. Residual Not Classified as Sludge, Managed by Hazardous or Waste Flow Regs.
7. Other (specify here: _____)
8. None Removed

EQUATIONS:

A. Dry tons = $\frac{\text{Gallons (wet)} \times \text{Solid Content (of the gallons)}}{240}$

B. Dry Tons = $\frac{\text{Cubic Yards (wet)} \times \text{Solid Content (of the cubic yards)}}{(y)}$

- y = 1.185 where solid content is less than 15%
- = 1.265 where solid content is 16% to 23%
- = 1.58 where solid content is 24% to 29%
- = 1.9 where solid content is greater than 30%

C. Dry Tons = Tons (wet) X Solid Content (of the wet tons)

D. Volatile Solids Reduction = $\frac{\text{VS before} - \text{VS after}}{\text{VS before} - (\text{VS before} \times \text{VS after})} \times 100$

NOTE: The total and volatile solid contents in the above equations must be expressed as a decimal, for example:

- 1% Total solids = .01
- 20% Total solids = .20

Alternative equations may be utilized if approved in writing by NJDEP
FORM T-VWX-008

New Jersey Department of Environmental Protection
Division of Water Resources

METALS AND SELECTED CHEMICAL PARAMETERS REPORT

DISCHARGE PERMIT NO.	REPORTING PERIOD	REPORTING CATEGORY
	MO. YR.	
I _ 1 _ 1 _ 1 _ 1 _ 1 _ I	I _ 1 _ I I _ 1 _ 1 _ 1 _ I	I _ I 121

FACILITY NAME: _____

SLUDGE SAMPLING LOCATION: _____

<u>PARAMETER</u>	<u>STORET CODE</u>	<u>TOTAL PHASE (dry weight basis, mg/kg)</u>	<u>NONE DETECTED</u>
<u>METALS:</u>			
Arsenic	01002	I _ 1 _ 1 _ 1 _ 1 _ 1 _ . _ 1 _ I	I _ I
Beryllium	01012	I _ 1 _ 1 _ 1 _ 1 _ 1 _ . _ 1 _ I	I _ I
Cadmium	61527	I _ 1 _ 1 _ 1 _ 1 _ 1 _ . _ 1 _ I	I _ I
Chromium	61512	I _ 1 _ 1 _ 1 _ 1 _ 1 _ . _ 1 _ I	I _ I
Copper	61506	I _ 1 _ 1 _ 1 _ 1 _ 1 _ . _ 1 _ I	I _ I
Iron	01045	I _ 1 _ 1 _ 1 _ 1 _ 1 _ . _ 1 _ I	I _ I
Lead	61503	I _ 1 _ 1 _ 1 _ 1 _ 1 _ . _ 1 _ I	I _ I

Mercury	01260	I _ 1 _ 1 _ 1 _ 1 _ 1 _ . _ 1 _ I	I _ I
Molybdenum	01062	I _ 1 _ 1 _ 1 _ 1 _ 1 _ . _ 1 _ I	I _ I
Nickel	61515	I _ 1 _ 1 _ 1 _ 1 _ 1 _ . _ 1 _ I	I _ I
Selenium	61518	I _ 1 _ 1 _ 1 _ 1 _ 1 _ . _ 1 _ I	I _ I
Zinc	61509	I _ 1 _ 1 _ 1 _ 1 _ 1 _ . _ 1 _ I	I _ I

SELECTED CHEMICAL PARAMETERS:

Total Nitrogen	00625	I _ 1 _ 1 _ 1 _ 1 _ 1 _ . _ 1 _ I	I _ I
Ammonia Nitrogen	71845	I _ 1 _ 1 _ 1 _ 1 _ 1 _ . _ 1 _ I	I _ I
Nitrate Nitrogen	71850	I _ 1 _ 1 _ 1 _ 1 _ 1 _ . _ 1 _ I	I _ I
Oil and Grease	00550	I _ 1 _ 1 _ 1 _ 1 _ 1 _ . _ 1 _ I	I _ I
Phenols	46000	I _ 1 _ 1 _ 1 _ 1 _ 1 _ . _ 1 _ I	I _ I
Phosphorus	00665	I _ 1 _ 1 _ 1 _ 1 _ 1 _ . _ 1 _ I	I _ I
Calcium	00916	I _ 1 _ 1 _ 1 _ 1 _ 1 _ . _ 1 _ I	I _ I
Magnesium	00927	I _ 1 _ 1 _ 1 _ 1 _ 1 _ . _ 1 _ I	I _ I
Potassium	00937	I _ 1 _ 1 _ 1 _ 1 _ 1 _ . _ 1 _ I	I _ I
Cyanide	00720	I _ 1 _ 1 _ 1 _ 1 _ 1 _ . _ 1 _ I	I _ I
Fluoride	00951	I _ 1 _ 1 _ 1 _ 1 _ 1 _ . _ 1 _ I	I _ I
Chloride	00940	I _ 1 _ 1 _ 1 _ 1 _ 1 _ . _ 1 _ I	I _ I

CERTIFICATION OF AUTHENTICITY:

Name of Authorized Agent(print): _____

Signature of Authorized Agent: _____ Date: _____

Title of Authorized Agent: _____

Laboratory Name: _____ Cert #: _____

PURGEABLES:

Benzene	34030	I_1_1_1_1_1_1_1_1_I	I_I
Carbon tetrachloride	32102	I_1_1_1_1_1_1_1_1_I	I_I
Chloroform	32106	I_1_1_1_1_1_1_1_1_I	I_I
Methylene Chloride	34423	I_1_1_1_1_1_1_1_1_I	I_I
Tetrachloroethylene	34475	I_1_1_1_1_1_1_1_1_I	I_I
Trichloroethylene	39180	I_1_1_1_1_1_1_1_1_I	I_I
Vinyl chloride	39175	I_1_1_1_1_1_1_1_1_I	I_I

BASE/NEUTRALS AND ACIDS:

Benzidine	39102	I_1_1_1_1_1_1_1_1_I	I_I
Benzo(a)pyrene	34247	I_1_1_1_1_1_1_1_1_I	I_I
Bis (2-ethylhexyl) phthalate	39100	I_1_1_1_1_1_1_1_1_I	I_I
Hexachlorobenzene	39700	I_1_1_1_1_1_1_1_1_I	I_I
Hexachlorobutadiene	39702	I_1_1_1_1_1_1_1_1_I	I_I
N-nitrosodimethylamine	34438	I_1_1_1_1_1_1_1_1_I	I_I
_____	_____	I_1_1_1_1_1_1_1_1_I	I_I
_____	_____	I_1_1_1_1_1_1_1_1_I	I_I

CERTIFICATION OF AUTHENTICITY:

Name of Authorized Agent(print): _____

Signature of Authorized Agent: _____ Date: _____

Title of Authorized Agent: _____

Laboratory Name: _____ Cert #: _____

FORM T-VWX-010A

New Jersey Department of Environmental Protection
Division of Water Resources

INDUSTRIAL PROCESS WASTEWATER SLUDGE REPORT

DISCHARGE PERMIT NO.

REPORTING PERIOD
MO. YR.

I _ 1 _ 1 _ 1 _ 1 _ 1 _ 1 _ I

I _ 1 _ I I _ 1 _ 1 _ 1 _ I

I4I Page I1I of I_ I

FACILITY NAME: _____

A. Information On Sludge Produced In Treatment Processes:

- 1. Average Daily Sludge Production (Dry Tons/Day) I _ 1 _ 1 _ . _ 1 _ 1 _ I
- 2. Average Daily Sludge Production (Gallons/Day) I _ 1 _ 1 _ 1 _ 1 _ 1 _ 1 _ I.
- 3. Average Total Solids of Sludge (% by weight) I _ 1 _ . _ I

*B. Information On Sludge Removed For Ultimate Management:

- 1. Average Daily Sludge Removal (Dry Tons/Day) I _ 1 _ 1 _ . _ 1 _ 1 _ I
- 2. Average Daily Sludge Removal (Gallons/Day) I _ 1 _ 1 _ 1 _ 1 _ 1 _ 1 _ I
- 3. Total Solids Before Dewatering (% by weight) I _ 1 _ . _ I
- 4. Total Solids After Dewatering (% by weight) I _ 1 _ . _ I
- 5. pH (Standard units) I _ 1 _ . _ I
- 6. COD (Chemical Oxygen Demand) (mg/l) I _ 1 _ 1 _ 1 _ 1 _ 1 _ I.
- 7. Total Oil and Grease (% by weight) I _ 1 _ . _ I

C. Disposal Method(s):

METHOD CODE	DESCRIPTION	LANDFILL REGISTRY	HAULER REGISTRY	RECEIVING PLANT
I _ I	I _ 1 _ 1 _ 1 _ 1 _ 1 _ 1 _ 1 _ 1 _ 1 _ 1 _ I	I _ 1 _ 1 _ 1 _ I	I _ 1 _ 1 _ 1 _ I	I _ 1 _ 1 _ 1 _ 1 _ 1 _ I
I _ I	I _ 1 _ 1 _ 1 _ 1 _ 1 _ 1 _ 1 _ 1 _ 1 _ 1 _ I	I _ 1 _ 1 _ 1 _ I	I _ 1 _ 1 _ 1 _ I	I _ 1 _ 1 _ 1 _ 1 _ 1 _ I
I _ I	I _ 1 _ 1 _ 1 _ 1 _ 1 _ 1 _ 1 _ 1 _ 1 _ 1 _ I	I _ 1 _ 1 _ 1 _ I	I _ 1 _ 1 _ 1 _ I	I _ 1 _ 1 _ 1 _ 1 _ 1 _ I

- **D. A. Total Nitrogen mg/kg I _ 1 _ 1 _ 1 _ 1 _ 1 _ I.
- B. Ammonia Nitrogen mg/kg I _ 1 _ 1 _ 1 _ 1 _ 1 _ I.
- C. Nitrate Nitrogen mg/kg I _ 1 _ 1 _ 1 _ 1 _ 1 _ I.
- D. Phosphorus mg/kg I _ 1 _ 1 _ 1 _ 1 _ 1 _ I.

E. Solid Waste Classification ID Number I _ 1 _ I

*Must be reported only if sludge is removed from Treatment Works site during the reporting period.
**Must be reported only if sludge is applied to land for soil improvement.

CERTIFICATION OF AUTHENTICITY:

Name of Authorized Agent (print): _____
 Signature of Authorized Agent: _____ Date: _____
 Title of Authorized Agent: _____
 Laboratory Name: _____ Cert. #: _____

APPENDIX C
PRIORITY POLLUTANTS

PURGEABLE ORGANIC PRIORITY POLLUTANTS:

1. Acrolein
2. Acrylonitrile
3. Benzene
4. Bromodichloromethane
5. Bromoform
6. Carbon Tetrachloride
7. Chlorobenzene
8. Chloroethane
9. 2-Chloroethylvinyl ether
10. Chloroform
11. Dibromochloromethane
12. 1,1-Dichloroethane
13. 1,2-Dichloroethane
14. 1,1-Dichloroethylene
15. 1,2-Dichloropropane
16. trans-1,3-Dichloropropene
17. Ethylbenzene
18. Methyl Bromide
19. Methyl Chloride
20. Methylene Chloride
21. 1,1,2,2-Tetrachloroethane
22. Tetrachloroethylene
23. Toluene
24. trans-1,2-Dichloroethylene
25. 1,1,1-Trichloroethane
26. 1,1,2-Trichloroethane
27. Trichloroethylene
28. Vinyl Chloride

ACID EXTRACTABLE PRIORITY POLLUTANTS:

29. 2-Chlorophenol
30. 2,4-Dichlorophenol
31. 2,4-Dimethylphenol
32. 4,6-Dinitro-o-cresol
33. 2,4-Dinitrophenol
34. 2-Nitrophenol
35. 4-Nitrophenol
36. p-Chloro-m-cresol
37. Pentachlorophenol
38. Phenol
39. 2,4,6-Trichlorophenol

BASE/NEUTRAL EXTRACTABLE PRIORITY POLLUTANTS:

40. Acenaphthene
41. Acenaphthylene
42. Anthracene
43. Benzidine
44. Benzo(a)anthracene
45. Benzo(a)pyrene
46. 3,4-Benzofluoranthene
47. Benzo(k)fluoranthene
48. Benzo(g,h,i)perylene
49. bis(2-Chloroethoxy)methane
50. bis(2-Chloroethyl)ether
51. bis(2-Chloroisopropyl)ether
52. bis(2-Ethylhexyl)phthalate
53. 4-Bromophenyl phenyl ether
54. Butyl benzyl phthalate
55. 2-Chloronaphthalene
56. 4-Chlorophenyl phenyl ether
57. Chrysene

58. Dibenzo(a,h)anthracene
59. 1,2-Dichlorobenzene
60. 1,3-Dichlorobenzene
61. 1,4-Dichlorobenzene
62. 3,3'-Dichlorobenzidine
63. Diethyl phthalate
64. Dimethyl phthalate
65. Di-n-butyl phthalate
66. 2,4-Dinitrotoluene
67. 2,6-Dinitrotoluene
68. Di-n-octyl phthalate
69. 1,2-Diphenylhydrazine
70. Fluoranthene
71. Fluorene
72. Hexachlorobenzene
73. Hexachlorobutadiene
74. Hexachlorocyclopentadiene
75. Hexachloroethane
76. Indeno(1,2, 3-c,d)pyrene
77. Isophorone
78. Naphthalene
79. Nitrobenzene
80. N-Nitrosodimethylamine
81. N-Nitrosodi-n-propylamine
82. N-Nitrosodiphenylamine
83. Phenanthrene
84. Pyrene
85. 1,2,4-Trichlorobenzene

PESTICIDE EXTRACTABLE PRIORITY POLLUTANTS:

86. Aldrin
87. alpha-BHC
88. beta-BHC
89. gamma-BHC (Lindane)
90. delta-BHC
91. Chlordane
92. 4,4'-DDT
93. 4,4'-DDE
94. 4,4'-DDE
95. Dieldrin
96. alpha-Endosulfan
97. beta-Endosulfan
98. Endosulfan sulfate
99. Endrin
100. Endrin aldehyde
101. Heptachlor
102. Heptachlor Epoxide
103. PCB-1242
104. PCB-1254
105. PCB-1221
106. PCB-1232
107. PCB-1248
108. PCB-1260
109. PCB-1016
110. Toxaphene

PRIORITY POLLUTANT METALS AND OTHER TOXIC POLLUTANTS:

111. Antimony
112. Arsenic
113. Beryllium
114. Cadmium
115. Chromium
116. Copper
117. Lead
118. Mercury
119. Nickel

- 120. Selenium
- 121. Silver
- 122. Thallium
- 123. Zinc
- 124. Cyanide
- 125. 2,3,7,8-Tetrachloro-dibenzo-p-dioxin

Lab. ID. No.	Authorized Agent	Title	Signature	Date Submitted
-----------------	---------------------	-------	-----------	-------------------

APPENDIX A-1

SLUDGE REPORT

Category	NPDES Permit No.	Reporting Period	
		Mon. Yr.	thru Mon. Yr.
1. Average Daily Sludge Production		Tons (dry basis)	
2. Average Daily Sludge Production		Gallons (wet basis)	
3. Volatile Solids Before Stabilization ¹		mg/L	
4. Volatile Solids After Stabilization ²		mg/L	
5. Percent Solids Before Dewatering		%	
6. Percent Solids After Dewatering		%	
7. Average Daily Ash Production (applicable for pyrolysis/incineration only)		Tons	
8. pH ³		Standard Units	
9. Average Daily Septage Treated		Gallons	
10. Method and Site of Disposal			

11. Landfill Registry No. (if applicable)

¹ Stabilization here refers to any of the following processes: anaerobic/aerobic digestion, lime stabilization, wet-air oxidation, etc.

² Need not be reported for composting.

³ pH readings should be taken immediately after sampling, or samples may be kept at 4°C and the readings taken within 6 hours of sampling.

Lab ID No.	Authorized Agent	Title	Signature	Date Submitted
---------------	---------------------	-------	-----------	-------------------

APPENDIX A-3

TOXIC ORGANIC COMPOUNDS REPORT

Category	NPDES Permit No.	Reporting Period		
		MON. YR.	thru	MON. YR.
		LIQUID PHASE (mg/kg)	SOLID PHASE (DRY BASIS)	TOTAL (mg/kg)
Aldrin		E-	E-	E-
Chlordane		E-	E-	E-
Dieldrin		E-	E-	E-
DDT		E-	E-	E-
Endrin		E-	E-	E-
Heptachlor		E-	E-	E-
Heptachlor Epoxide		E-	E-	E-
Lindane		E-	E-	E-
Methoxychlor		E-	E-	E-
Mirex		E-	E-	E-
PCB'S		E-	E-	E-
PP-DDE		E-	E-	E-
PP-TDE		E-	E-	E-
Toxaphene		E-	E-	E-

Lab. ID. No.	Authorized Agent	Title	Signature	Date Submitted
-----------------	---------------------	-------	-----------	-------------------

APPENDIX A-2

HEAVY METALS AND SELECTED
CHEMICAL PARAMETERS

Category	NPDES Permit No.	Reporting Period		
		MON	YR thru	MON YR
1		LIQUID PHASE (mg/kg)	SOLID PHASE (DRY BASIS)	TOTAL (mg/kg)
Arsenic		E-	E-	E-
Cadmium		E-	E-	E-
Chromium		E-	E-	E-
Copper		E-	E-	E-
Lead		E-	E-	E-
Mercury		E-	E-	E-
Nickel		E-	E-	E-
Zinc		E-	E-	E-
Total Nitrogen		E-	E-	E-
Ammonia Nitrogen		E-	E-	E-
Nitrate Nitrogen		E-	E-	E-
Oils & Grease		E-	E-	E-
Phenols		E-	E-	E-
Phosphorus		E-	E-	E-
Calcium		E-	E-	E-
Magnesium		E-	E-	E-
Potassium		E-	E-	E-
Cyanide		E-	E-	E-

APPENDIX A-4

INDUSTRIAL PROCESS WASTEWATER
SLUDGE REPORT

Permit No.	Reporting Period	
	Mon. Yr.	thru Mon. Yr.
1. Average Daily Sludge Production	Tons (dry basis)	
2. Average Daily Sludge Production	Gallons (wet basis)	
3. Percent Total Solids before dewatering	Percent	
4. Percent Total Solids after dewatering	Percent	
5. Average Daily Ash Production	Tons	
* 6. pH	Standard Units	
7. COD (Chemical Oxygen Demand)	mg/L	
8. Oil and Grease	Percent	
9. Method and Site of Sludge Disposal		
10. Landfill Registry No. (if applicable)		
** 11. a. Total Nitrogen	mg/kg	
b. Ammonia Nitrogen	mg/kg	
c. Nitrate Nitrogen	mg/kg	
d. Phosphorus	mg/kg	
Toxic and/or Inhibitory Pollutant No.		

CAS No.		CAS No.	
56235	carbon tetrachloride (tetrachloromethane)	72208	endrin
57749	chlordane (technical mixture and metabolites)	7421934	endrin aldehyde
95512	2-chloroaniline	53494705	endrin ketone
108429	3-chloroaniline	100414	ethylbenzene
106478	4-chloroaniline	106934	ethylene dibromide
108907	chlorobenzene	151564	ethyleneimine (Aziridine)
124481	chlorodibromomethane	206440	fluoranthene
110753	2-chloroethyl vinyl ether (mixed)	86737	fluorene
67663	chloroform (trichloromethane)	76448	heptachlor
91587	2-chloronaphthalene	1024573	heptachlor epoxide
* Chemical Abstracts Service Number		118741	hexachlorobenzene
88733	2-chloronitrobenzene	87683	hexachlorobutadiene
100005	4-chloronitrobenzene	77474	hexachlorocyclopentadiene
25167800	2-chlorophenol	67721	hexachloroethane
7005723	4-chlorophenyl phenyl ether	302012	hydrazine
126998	chloroprene	193395	indeno (1,2,3-C,D) pyrene
7440473	chromium (total)	78591	isophorone
218019	chrysene	7439921	lead (total)
532821	chrysolidine	7439976	mercury (total)
744058	copper (total)	101144	4,4'-methylene bis (2-chloroaniline)
98828	cumene	101779	4,4'-methylene dianiline
57125	cyanide (total)	108101	methylisobutyl ketone
72548	p,p'-DDD (p,p'-TDE)	91203	naphthalene
72559	p,p'-DDE (p,p'-DDX)	134327	alpha naphthylamine
50293	p,p'-DDT	91598	beta naphthylamine
53703	1,2:5,6-dibenzanthracene	7440020	nickel (total)
608275	2,3-dichloroaniline	98953	nitrobenzene
554007	2,4-dichloroaniline	88755	2-nitrophenol
95829	2,5-dichloroaniline	100027	4-nitrophenol
95761	3,4-dichloroaniline	1321126	nitrotoluene
626437	3,5-dichloroaniline	100618	N-methylaniline
95501	1,2-dichlorobenzene	62759	N-nitrosodimethylamine
541731	1,3-dichlorobenzene	621647	N-nitrosodi-n-propylamine
106467	1,4-dichlorobenzene	86306	N-nitrosodiphenylamine
91941	3,3'-dichlorobenzidine	59507	parachlorometacresol
75274	dichloroboromomethane		PCB-1016 (Aroclor 1016)
75343	1,1-dichloroethane	11097691	PCB-1221 (Aroclor 1221)
107062	1,2-dichloroethane		PCB-1232 (Aroclor 1232)
156592	1,2-dichloroethylene (trans)		PCB-1242 (Aroclor 1242)
75092	dichloromethane (methylene chloride)		PCB-1248 (Aroclor 1248)
120832	2,4-dichlorophenol		PCB-1254 (Aroclor 1254)
78875	1,2-dichloropropane		PCB-1260 (Aroclor 1260)
542756	1,3-dichloropropane	87865	pentachlorophenol
60571	dieldrin	85018	phenanthrene
84662	diethyl phthalate	108952	phenol
117817	di(2-ethylhexyl) phthalate	95545	1,2-phenylenediamine
85687	butyl benzyl phthalate	108452	1,3-phenylenediamine
131113	dimethyl phthalate	106503	1,4-phenylenediamine
84742	di-n-butyl phthalate	129000	pyrene
117840	di-n-octyl phthalate	7782492	selenium (total)
119904	3,3'-dimethoxybenzidine	7440224	silver (total)
121697	dimethylaniline	842079	sudan I (solvent yellow 14)
119937	3,3'-dimethylbenzidine	1746016	2,3,7,8-tetrachlorodibenzo-p-dioxin (TCDD)
57147	1,1-dimethylhydrazine	79345	1,1,2,2-tetrachloroethane
105679	2,4-dimethylphenol	127184	tetrachloroethylene
534521	4,6-dinitro-o-cresol	7440280	thallium (total)
51285	2,4-dinitrophenol	62566	thiourea
121142	2,4-dinitrotoluene	108883	toluene
606202	2,6-dinitrotoluene	104154	toluene sulfonic acids
123911	1,4-dioxane (1,4-diethylene dioxide)	26915128	toluidines
122394	diphenylamine	8001352	toxaphene
122667	1,2-diphenylhydrazine	120821	1,2,4-trichlorobenzene
959988	endosulfan-I	71556	1,1,1-trichloroethane
33213659	endosulfan-II	79005	1,1,2-trichloroethane
1031078	endosulfan sulfate	79016	trichloroethylene
		88062	2,4,6-trichlorophenol

CAS No.	
1300716	xyleneols
1300738	xylydines
7440666	zinc (total)

APPENDIX B-3

POLLUTANTS THAT ARE INHIBITORY TO BIOLOGICAL TREATMENT PROCESSES

CAS No.	
	INORGANIC POLLUTANTS
14213979	Borate (Boron)
7440473	Chromium
7439965	Manganese
7440622	Vanadium

ORGANIC POLLUTANTS

107186	Allyl alcohol
57067	Allyl isothiocyanate
141435	2-Aminoethanol (mono ethanolamine)
538283	Benzyl thiuronium chloride
4170303	Crotonaldehyde
97234	Dichlorophen
591355	3,5-dichlorophenol
138896	Dimethylparanitrosoaniline
86566	N,N-dimethyl-1-naphthylamine
593851	Guanidine carbonate
124094	Hexamethylenediamine
148243	8-hydroxyquinoline
556616	Methyl isothiocyanate
867447	Methyl thiuronium sulphate
107197	Propargyl alcohol
83341	Skatole
128041	Sodium dimethyl dithiocarbamate
137428	Sodium methyl dithiocarbamate
137268	Tetramethyl thiuram disulphide
97745	Tetramethyl thiuram monosulphide
79196	Thiosemicarbazide

APPENDIX C

SEPARATION OF LIQUID AND SOLID PHASES FOR ANALYSIS OF INORGANIC AND ORGANIC COMPONENTS

Analytical results for inorganic and organic components are to be determined using the following method of separation:

1. Analyze component content on a completely mixed portion of sample. Analysis is to be reported as Mg component /Kg of total sample. Assume 1 ml. = 1 gram.
- 2a. For the liquid phase separation of the pesticides and PCBs centrifuge a portion of the completely mixed sample and carefully decant a portion of the liquid phase. Analyze the decant to determine Mg component /Kg of liquid phase.

b. For the liquid phase separation of other components centrifuge another portion of completely mixed sample. Pass supernatant through a membrane filter. * Analyze a portion of filtrate to determine Mg component /Kg of liquid phase.

3. Determine the % suspended solids on another portion of completely mixed sample.

4. Calculate the MG component /Kg of solid phase as follows:

$$\frac{\text{Mg component}}{\text{Kg of solid phase}} = \frac{\frac{\text{Mg component}}{\text{Kg of total sample}} - \frac{100 - \% \text{ solids}}{100} \times \frac{\text{Mg component}}{\text{Kg of liquid phase}}}{\frac{\% \text{ solids}}{100}}$$

* Use membrane filter discs which are resistant to acids and organic solvents.

APPENDIX D

WORDING OF FINANCIAL ASSURANCE DOCUMENTS

LETTER OF CREDIT

A letter of credit required by N.J.A.C. 7:14-8.4(a) shall be worded as follows, except that instructions in brackets are to be replaced with the relevant information and the brackets deleted.

Irrevocable Letter of Credit

New Jersey Department of Environmental Protection
 CN 029
 Trenton, New Jersey 08625
 ATTN: Assistant Director, Enforcement
 Division of Water Resources

RE: [Name of Violator]
 Adjudicatory Hearing Request

Dear Sir or Madam:

We hereby establish our irrevocable standby Letter of Credit No. _____ in the favor of the New Jersey Department of Environmental Protection, at the request and for the account of [violator's name and address of facility at which violation occurred] up to the aggregate amount of [in words] U.S. dollars _____, available upon presentation by the New Jersey Department of Environmental Protection of (1) a sight draft, bearing reference to this irrevocable standby Letter of Credit No. _____, and (2) a signed statement reading as follows:

"I certify that the amount of the draft is payable pursuant to the authority of the Water Pollution Control Act, N.J.S.A. 58:10A-1 et seq.

This Letter of Credit is effective as of [insert month, day, and year] and shall expire on [date at least 1 year later], but such expiration date shall be automatically extended for a period of at least one (1) year on [date] and on each

successive expiration date, unless, at least 120 days before the current expiration date, we notify both NJDEP's Assistant Director for Enforcement, Division of Water Resources, CN-029, Trenton, New Jersey, 08625, and [name and address of violator] by certified mail that we have decided not to extend this Letter of Credit beyond the current expiration date. In the event you are so notified, any unused portion of the credit shall be available upon presentation of your sight draft for 120 days after the date of receipt by both NJDEP and [name and address of violator], as shown on the signed return receipts.

Whenever this Letter of Credit is drawn on under and in compliance with the terms of this credit, we shall duly honor such draft upon presentation to us, and we shall deposit the amount of the draft directly into the standby trust fund of [name of violator] or in accordance with your instructions.

We certify that the wording of this Letter of Credit is identical to the wording specified in N.J.A.C. 7:14-8 Appendix A, as such regulations were constituted on [the date shown immediately below].

[Name of issuing institution] shall not cancel this Letter of Credit on the basis of a request from [name violator] until [name of issuing institution] has received written authorization from NJDEP.

This irrevocable standby Letter of Credit is subject to [insert either "the most recent edition of the 'Uniform Customs and Practice for Documentary Credits,' published by the International Chamber of Commerce," or "the Uniform Commercial Code"].

This letter of credit sets forth in full our undertaking, and such undertaking shall not in any way be modified, amended, amplified or limited by reference to any other document, instrument or agreement referred to herein, except for the sight draft and your signed statement referred to herein. Any such reference shall not be deemed to incorporate herein by reference any document, instrument or agreement except for such sight draft and signed statement.

Very truly yours,
 [Name of Issuing Institution]
 [Signature and Title of Official]
 [Printed Name of Official]
 [Date]

SURETY BOND

A surety bond guaranteeing payment into a trust fund required by N.J.A.C. 7:14-8.4(a) shall be worded as follows, except that instructions in brackets are to be replaced with the relevant information and the brackets deleted.

Financial Guarantee Bond

RE: ADJUDICATORY HEARING REQUEST
 NAME OF VIOLATOR _____
 ADDRESS OF FACILITY AT WHICH VIOLATION
 OCCURRED _____

Date bond executed: _____

Effective date: _____

Principal: [Legal name and business address of violator]

Type of organization [insert "individual", "joint venture", "partnership", or "corporation"]

State of incorporation: _____

[Insert name of violator, location of facility at which the violation occurred, including street address, lot and block number, municipality and county, and the financial assurance guaranteed by this bond]

Total penal sum of bond: _____

Surety bond number: _____

Know All Persons By These Presents, That we, the Principal and Surety(ies) hereto are firmly bound to the New Jersey Department of Environmental Protection, hereinafter NJDEP, in the above penal sum for the payment of which we bind ourselves, our heirs, executors, administrators, successors and assigns, jointly and severally; provided that, where the Surety(ies) are corporations acting as co-sureties, we, the Sureties, bind ourselves in such sum "jointly and severally" only for the purpose of allowing a joint action or actions against any or all of us, and for all other purposes, each Surety binds itself, jointly and severally with the Principal, for the payment of such sum only as is set forth opposite the name of such Surety, but if no limit of liability is indicated, the limit of liability shall be the full amount of the penal sum.

WHEREAS, the Principal is required to provide financial assurance in an amount equal to the amount of the civil administrative penalty in the Notice of Civil Administrative Penalty Assessment dated [date] as a precondition to requesting an adjudicatory hearing on the Notice of Civil Administrative Penalty Assessment pursuant to N.J.A.C. 7:14-8.4(a), and

WHEREAS, the Principal shall establish a standby trust fund as is required by N.J.A.C. 7:14-8(a)9. when a surety bond is used to provide a mechanism for access by NJDEP to assure payment of the civil administrative penalty in the Notice of Civil Administrative Penalty Assessment dated [date];

NOW, THEREFORE, the conditions of this obligation are such that if the Principal pays the full amount of the civil administrative penalty that is due and owing pursuant to the Notice of Civil Administrative Penalty Assessment, then this obligation shall be null and void, otherwise, it is to remain in full force and effect.

The Surety(ies) shall become liable on this bond obligation only when the Principal has failed to pay the civil administrative penalty when due and owing. Upon notification by the NJDEP that the Principal has failed to perform as guaranteed by this bond, the Surety(ies) shall place funds in the amount guaranteed for the violator into the standby trust fund as directed by the NJDEP.

The liability of the Surety(ies) shall not be discharged by any payment or succession of payments hereunder, unless and until such payment or payments shall amount in the aggregate to the penal sum of the bond, but in no event shall the obligation of the Surety(ies) hereunder exceed the amount of the penal sum.

The Surety(ies) may cancel the bond by sending notice of cancellation by certified mail to the Principal and to the NJDEP Assistant Director for Enforcement, Division of Water Resources, CN-029, Trenton, N.J., 08625; provided, however, the cancellation shall not occur during the 120 days beginning on the date of receipt of the notice of cancellation by both the Principal and the NJDEP, as evidenced by the return receipts.

The Principal may terminate this bond by sending written notice to the Surety(ies); provided, however, that no such notice shall become effective until the Surety(ies) receive(s) written authorization for termination of the bond by the NJDEP.

In Witness Whereof, the Principal and Surety(ies) have executed this Financial Guarantee Bond and have affixed their seals on the date set forth below.

The persons whose signatures appear below hereby certify that they are authorized to execute this surety on behalf of the Principal and Surety(ies) and that the wording of this surety bond is identical to the wording required in N.J.A.C. 7:14-8 Appendix A as constituted on the date the bond was established.

Principal _____
[Signature(s)] _____
Date _____
[Name(s)] _____
[Title(s)] _____
[Corporate seal] _____

[Name and address] _____
State of incorporation: _____
Liability limit: _____
[Signature(s)] _____
Date _____
[Name(s) and title(s)] _____
[Corporate seal] _____
[For every co-surety, provide signature(s), corporate seal, and other information in the same manner as for Surety above.]
Bond premium: _____

STANDBY TRUST AGREEMENT

A Standby Trust Agreement required by N.J.A.C. 7:14-8.4(a) shall be worded as follows, except that instructions in brackets are to be replaced with the relevant information and the brackets deleted.

Standby Trust Agreement

RE: ADJUDICATORY HEARING REQUEST
NOTICE OF CIVIL ADMINISTRATIVE PENALTY
ASSESSMENT DATED [date] _____
NAME OF VIOLATOR _____
ADDRESS OF FACILITY AT WHICH VIOLATION
OCCURRED _____

This Standby Trust Agreement, hereinafter "Agreement", entered into as of [date] by and between [name and address of the violator], a New Jersey [insert "corporation", "partnership", "association", or "proprietorship"], hereinafter "Grantor" and [name and address of corporate trustee], [insert "incorporated in the State of" or "a national bank"], hereinafter "Trustee".

WHEREAS, the Grantor is required to provide financial assurance in an amount equal to the amount of the civil administrative penalty in the Notice of Civil Administrative Penalty Assessment dated [date] as a precondition to requesting an adjudicatory hearing on the Notice of Civil Administrative Penalty Assessment pursuant to N.J.A.C. 7:14-8.4(a), and

WHEREAS, The Grantor, acting through its duly authorized officer or management official, has selected the Trustee under this Agreement, and the Trustee is willing to act as Trustee.

NOW, THEREFORE, the Grantor and the Trustee agree as follow:

Section 1. Definitions

As used in this Agreement:

(a) The term "Grantor" means the violator who is requesting an adjudicatory hearing on the Notice of Civil Administrative Penalty Assessment referenced above, and any successors or assigns of the Grantor.

(b) The term "Trustee" means the Trustee who enters into the Agreement and any successor Trustee.

Section 2. Identification of Site or Facility at which the Violation(s) referenced in the Notice of Civil Administrative Penalty Assessment Occurred and Amount of Financial Assurance

This Agreement pertains to the site or facility at which the violation(s) referenced in the Notice of Civil Administrative Penalty Assessment occurred and the full amount of the civil administrative penalty in the Notice of Civil Administrative Penalty Assessment dated [date] which is included herein as Attachment A.

Section 3. Establishment of Fund

The Grantor and the Trustee hereby establish a trust fund, hereinafter the "Fund", for the benefit of NJDEP. The Grantor and the Trustee intend that no third party shall have access to the fund except as herein provided. The Fund is established initially as consisting of the total sum of [dollar amount] which is acceptable to the Trustee and NJDEP. Such property and any other property subsequently transferred to the Trustee is referred to as the Fund, together with all earnings and profits thereon, less any payments or distributions made by the Trustee pursuant to this Agreement. The Fund shall be held by the Trustee, IN TRUST, as hereinafter provided. The Trustee shall not be responsible nor shall it undertake any responsibility for the amount or adequacy of, nor any duty to collect from the Grantor, any payments necessary to discharge any liabilities of the Grantor established by the NJDEP.

Section 4. Payment for The Civil Administrative Penalty in the Notice of Civil Administrative Penalty Assessment dated [date]

The Trustee shall make payment from the Fund as the NJDEP Commissioner, or his designee, shall direct, in writing, to provide for the payment of the civil administrative penalty in the Notice of Civil Administrative Penalty Assessment dated [date]. In addition, the Trustee shall refund to the Grantor such amounts the NJDEP specifies in writing. Upon refund such funds shall no longer constitute part of the Fund as defined herein.

Section 5. Payments Comprising the Fund

Payments made to the Trustee for the Fund shall consist of cash or securities acceptable to the Trustee.

Section 6. Trustee Management

At such time as the corpus of the Fund is funded with more than one dollar, the Trustee shall invest and reinvest the principal and income of the Fund and keep the Fund invested as a single fund, without distinction between principal and income, in accordance with general investment policies and guidelines which the Grantor may communicate in writing to the Trustee from time to time, subject, however, to the provisions of this Section. In investing, reinvesting, exchanging, selling and managing the Fund, the Trustee shall discharge his duties with respect to the Fund solely in the interest of the NJDEP as the beneficiary and with the care, skill, prudence and diligence under the circumstances then prevailing which persons of prudence, acting in a like capacity and familiar with such matters, would use in the conduct of an enterprise of a like character and with like aims; except that:

(i) Securities or other obligations of the Grantor, or any other owner or operator of the site or facility at which the violation(s) occurred or any of their affiliates, as defined in the Investment Company Act of 1940, as amended, 15 U.S.C. 80a-2(a), shall not be acquired or held, unless they are securities or other obligations of the Federal or a state government;

(ii) The Trustee is authorized to invest the Fund in time or demand deposits of the Trustee, to the extent insured by an agency of the Federal or state government; and

(iii) The Trustee is authorized to hold cash awaiting investment of distribution uninvested for a reasonable time and without liability for the payment of interest thereon.

Section 7. Commingling and Investment

The Trustee is expressly authorized in its discretion:

(a) To transfer from time to time any or all of the assets of the Fund to any common, commingled or collective trust fund created by the Trustee in which the Fund is eligible to participate, subject to all of the provisions thereof, to be commingled with the assets of other trusts participating therein; and

(b) To purchase shares in any investment company registered under the Investment Company Act of 1940, 15 U.S.C. 80a-1 et seq., including one which may be created, managed, underwritten, or to which investment advice is rendered or the shares of which are sold by the Trustee. The Trustee may vote such shares in its discretion.

Section 8. Express Powers of Trustee

Without in any way limiting the powers and discretions conferred upon the Trustee by the other provisions of this Agreement or by law, the Trustee is expressly authorized and empowered:

(a) To sell, exchange, convey, transfer or otherwise dispose of any property held by it, by public or private sale. No person dealing with the Trustee shall be bound to see to the application of the purchase money or to inquire into the validity or expedience of any such sale or other disposition;

(b) To make, execute, acknowledge and deliver any and all documents of transfer and conveyance and any and all other instruments that may be necessary or appropriate to carry out the powers herein granted;

(c) To register any securities held in the Fund in its own name or in the name of a nominee and to hold any security in bearer form or in book entry, or to combine certificates representing such securities with certificates of the same issue held by the Trustee in other fiduciary capacities, or to deposit or arrange for the deposit of such securities in a qualified central depository even though, when so deposited, such securities may be merged and held in bulk in the name of the nominee of such depository with other securities deposited therein by another person, or to deposit or arrange for the deposit of any securities issued by the Federal Government of the United States or any agency or instrumentality thereof, with a Federal Reserve bank, but the books and records of the Trustee shall at all times show that all securities are part of the Fund;

(d) To deposit any cash in the Fund in interest-bearing accounts maintained or savings certificates issued by the Trustee, in its separate corporate capacity, or in any other banking institution affiliated with the Trustee, to the extent insured by an agency of the Federal or state government; and

(e) To compromise or otherwise adjust all claims in favor of or against the Fund.

Section 9. Taxes and Expenses

All taxes of any kind that may be assessed or levied against or in respect of the fund and all brokerage commissions incurred by the Fund shall be paid from the Fund. All other expenses incurred by the Trustee in connection with the administration of this Trust, including fees for legal services rendered to the Trustee, the compensation of the Trustee to the extent not paid directly by the Grantor and all other proper charges and disbursements of the Trustee, shall be paid from the Fund.

Section 10. Annual Valuation

The Trustee shall, annually, at least 30 days prior to the anniversary date of establishment of the Fund, furnish to the Grantor and to the NJDEP a statement confirming the value of the Trust. Any securities in the Fund shall be valued at market value as of no more than 60 days prior to the anniversary date of establishment of the Fund. The failure of the Grantor to object in writing to the Trustee within 90 days after the statement has been furnished to the Grantor and the NJDEP shall constitute a conclusively

binding assent by the Grantor, barring the Grantor from asserting any claim or liability against the Trustee with respect to matters disclosed in the statement.

Section 11. Advice of Counsel

The Trustee may, from time to time, consult with counsel, who may be counsel to the Grantor, with respect to any questions arising as to the construction of this Agreement or any action to be taken hereunder. The Trustee shall be fully protected, to the extent permitted by law, in acting upon the advice of counsel.

Section 12. Trustee Compensation

The Trustee shall be entitled to reasonable compensation, from time to time, for its services, as agreed upon in writing with the Grantor.

Section 13. Successor Trustee

The Trustee may resign or the Grantor may replace the Trustee, but such resignation or replacement shall not be effective until the Grantor has appointed a successor trustee and this successor accepts the appointment. The successor trustee shall have the same powers and duties as those conferred upon the Trustee hereunder. Upon the successor trustee's acceptance of the appointment, the Trustee shall assign, transfer and pay over to the successor Trustee the funds and properties constituting the Fund. If for any reason, the Grantor cannot or does not act in the event of the resignation of the Trustee, the Trustee may apply to a court of competent jurisdiction for the appointment of a successor Trustee or for instructions. The successor trustee shall specify the date on which it assumes administration of the trust in writing sent to the Grantor, the NJDEP and the present Trustee by certified mail 10 days before such change becomes effective. Any expenses incurred by the Trustee as a result of any of the acts contemplated by this Section shall be paid as provided in Section 9.

Section 14. Successor Grantor

Sixty days prior to the Grantor ceasing to exist, if dissolution is contemplated, the Grantor must notify and provide NJDEP with the names and addresses of any and all successors and assigns along with a notarized acknowledgement from same stating that the successors and assigns assume responsibilities concerning financial assurance.

Section 15. Instructions to the Trustee

All orders, requests and instructions by the Grantor to the Trustee shall be in writing, signed by such persons as are designated in Attachment B or such other designees as the Grantor may designate by amendment to Attachment B. The Trustee shall be fully protected in acting without inquiry in accordance with the Grantor's orders, requests and instructions. All orders, requests and instructions by the NJDEP to the Trustee shall be in writing, signed by the NJDEP Commissioner or his/her designee and the Trustee

shall act and shall be fully protected in acting in accordance with such orders, requests and instructions. The Trustee shall have the right to assume, in the absence of written notice to the contrary, that no event constituting a change or a termination of the authority of any person to act on behalf of the Grantor of NJDEP hereunder has occurred.

The Trustee shall have no duty to act in the absence of such orders, requests and instructions from the Grantor and/or NJDEP, except as provided for herein.

Section 16. Amendment of Agreement

This agreement may be amended by an instrument in writing executed jointly by the Grantor or the Grantor's principals, successors, and assigns if Grantor has dissolved, the Trustee and the NJDEP or by the Trustee and the NJDEP if the Grantor ceases to exist and no successors or assigns are named.

Section 17. Irrevocability and Termination

Subject to the right of the parties to amend this Agreement, as provided in Section 16, this Trust shall be irrevocable and shall continue until terminated at the written agreement of the Grantor, the Trustee and the NJDEP or of the Trustee and the NJDEP, if the Grantor ceases to exist. Upon termination of the Trust, all remaining trust property, less final trust administration expenses, shall be delivered to the Grantor.

Section 18. Immunity and Indemnification

The Trustee shall not incur personal liability of any nature in connection with any act or omission, made in good faith, in the administration of this Trust or in carrying out any directions by the Grantor or the NJDEP issued in accordance with the Agreement. The Trustee shall be indemnified and saved harmless by the Grantor or from the Trust Fund, or both, from and against any personal liability to which the Trustee may be subjected by reason of any act or conduct in its official capacity, including all expenses reasonably incurred in its defense in the event the Grantor fails to provide such defense.

Section 19. Choice of Law

This Agreement shall be administered, construed, and enforced according to the laws of the State of New Jersey.

Section 20. Interpretation

As used in this Agreement, words in the singular include the plural and words in the plural include the singular.

The descriptive headings for each Section of this Agreement shall not affect the interpretation or the legal efficacy of this Agreement.

In Witness Whereof, the parties have caused this Agreement to be executed by their respective officer or management officials, duly authorized, and their corporate seals to be hereunto affixed and attested, as of the date set forth below:

[NAME OF GRANTOR]

DATE: _____ By: _____
TITLE: _____

[NAME OF TRUSTEE]

DATE: _____ BY: _____
TITLE: _____

[Grantor shall attach Attachments A and B.]

FULLY FUNDED TRUST

A fully funded trust required by N.J.A.C. 7:14-8.4(a) shall be worded as follows, except that instructions in brackets are to be replaced with the relevant information and the brackets deleted.

Trust Agreement

RE: ADJUDICATORY HEARING REQUEST
NOTICE OF CIVIL ADMINISTRATIVE PENALTY
ASSESSMENT DATED [date] _____
NAME OF VIOLATOR _____
ADDRESS OF FACILITY AT WHICH VIOLATION
OCCURRED _____

This Fully Funded Trust, hereinafter "Agreement", entered into as of [date] by and between [name and address of the violator], a New Jersey [insert "corporation", "partnership", "association", or "proprietorship"], hereinafter "Grantor" and [name and address of corporate trustee], [insert "incorporated in the State of " or "a national bank"], hereinafter "Trustee".

WHEREAS, the Grantor is required to provide financial assurance in an amount equal to the amount of the civil administrative penalty in the Notice of Civil Administrative Penalty Assessment dated [date] as a precondition to requesting an adjudicatory hearing on the Notice of Civil Administrative Penalty Assessment pursuant to N.J.A.C. 7:14-8.4(a), and

WHEREAS, The Grantor, acting through its duly authorized officer or management official, has selected the Trustee under this Agreement, and the Trustee is willing to act as Trustee.

NOW, THEREFORE, the Grantor and the Trustee agree as follow:

Section 1. Definitions

As used in this Agreement:

(a) The term "Grantor" means the violator who is requesting an adjudicatory hearing on the Notice of Civil Administrative Penalty Assessment referenced above, and any successors or assigns of the Grantor.

(b) The term "Trustee" means the Trustee who enters into the Agreement and any successor Trustee.

Section 2. Identification of Site or Facility at which the Violation(s) referenced in the Notice of Civil Administrative Penalty Assessment Occurred and Amount of Financial Assurance

This Agreement pertains to the site or facility at which the violation(s) referenced in the Notice of Civil Administrative Penalty Assessment occurred and the full amount of the civil administrative penalty in the Notice of Civil Administrative Penalty Assessment dated [date] which is included herein as Attachment A.

Section 3. Establishment of Fund

The Grantor and the Trustee hereby establish a trust fund, hereinafter the "Fund", for the benefit of NJDEP. The Grantor and the Trustee intend that no third party shall have access to the fund except as herein provided. The Fund is established initially as consisting of the total sum of [dollar amount] which is acceptable to the Trustee and NJDEP. Such property and any other property subsequently transferred to the Trustee is referred to as the Fund, together with all earnings and profits thereon, less any payments or distributions made by the Trustee pursuant to this Agreement. The Fund shall be held by the Trustee, IN TRUST, as hereinafter provided. The Trustee shall not be responsible nor shall it undertake any responsibility for the amount or adequacy of, nor any duty to collect from the Grantor, any payments necessary to discharge any liabilities of the Grantor established by the NJDEP.

Section 4. Payment for The Civil Administrative Penalty in the Notice of Civil Administrative Penalty Assessment dated [date]

The Trustee shall make payment from the Fund as the NJDEP Commissioner, or his designee, shall direct, in writing, to provide for the payment for the civil administrative penalty in the Notice of Civil Administrative Penalty Assessment dated [date]. In addition, the Trustee shall refund to the Grantor such amounts the NJDEP specifies in writing. Upon refund such funds shall no longer constitute part of the Fund as defined herein.

Section 5. Payments Comprising the Fund

Payments made to the Trustee for the Fund shall consist of cash or securities acceptable to the Trustee.

Section 6. Trustee Management

At such time as the corpus of the Fund is funded, the Trustee shall invest and reinvest principal and income of the

Fund and keep the Fund invested as a single fund, without distinction between principal and income, in accordance with general investment policies and guidelines which the Grantor may communicate in writing to the Trustee from time to time, subject, however, to the provisions of this Section. In investing, reinvesting, exchanging, selling and managing the Fund, the Trustee shall discharge his duties with respect to the Fund solely in the interest of the NJDEP as the beneficiary and with the care, skill, prudence and diligence under the circumstances then prevailing which persons of prudence, acting in a like capacity and familiar with such matters, would use in the conduct of an enterprise of a like character and with like aims; except that:

(i) Securities or other obligations of the Grantor, or any other owner or operator of the site or facility at which the violation(s) occurred or any of their affiliates, as defined in the Investment Company Act of 1940, as amended, 15 U.S.C. 80a-2(a), shall not be acquired or held, unless they are securities or other obligations of the Federal or a state government;

(ii) The Trustee is authorized to invest the Fund in time or demand deposits of the Trustee, to the extent insured by an agency of the Federal or State government; and

(iii) The Trustee is authorized to hold cash awaiting investment of distribution uninvested for a reasonable time and without liability for the payment of interest thereon.

Section 7. Commingling and Investment

The Trustee is expressly authorized in its discretion:

(a) To transfer from time to time any or all of the assets of the Fund to any common, commingled or collective trust fund created by the Trustee in which the Fund is eligible to participate, subject to all of the provisions thereof, to be commingled with the assets of other trusts participating therein; and

(b) To purchase shares in any investment company registered under the Investment Company Act of 1940, 15 U.S.C. 80a-1 et seq., including one which may be created, managed, underwritten, or to which investment advice is rendered or the shares of which are sold by the Trustee. The Trustee may vote such shares in its discretion.

Section 8. Express Powers of Trustee

Without in any way limiting the powers and discretions conferred upon the Trustee by the other provisions of this Agreement or by law, the Trustee is expressly authorized and empowered:

(a) To sell, exchange, convey, transfer or otherwise dispose of any property held by it, by public or private sale. No person dealing with the Trustee shall be bound to see to

the application of the purchase money or to inquire into the validity or expedience of any such sale or other disposition;

(b) To make, execute, acknowledge and deliver any and all documents of transfer and conveyance and any and all other instruments that may be necessary or appropriate to carry out the powers herein granted;

(c) To register any securities held in the Fund in its own name or in the name of a nominee and to hold any security in bearer form or in book entry, or to combine certificates representing such securities with certificates of the same issue held by the Trustee in other fiduciary capacities, or to deposit or arrange for the deposit of such securities in a qualified central depository even though, when so deposited, such securities may be merged and held in bulk in the name of the nominee of such depository with other securities deposited therein by another person, or to deposit or arrange for the deposit of any securities issued by the Federal Government of the United States or any agency or instrumentality thereof, with a Federal Reserve bank, but the books and records of the Trustee shall at all times show that all securities are part of the Fund;

(d) To deposit any cash in the Fund in interest-bearing accounts maintained or savings certificates issued by the Trustee, in its separate corporate capacity, or in any other banking institution affiliated with the Trustee, to the extent insured by an agency of the Federal or State government; and

(e) To compromise or otherwise adjust all claims in favor of or against the Fund.

Section 9. Taxes and Expenses

All taxes of any kind that may be assessed or levied against or in respect of the fund and all brokerage commissions incurred by the Fund shall be paid from the Fund. All other expenses incurred by the Trustee in connection with the administration of this Trust, including fees for legal services rendered to the Trustee, the compensation of the Trustee to the extent not paid directly by the Grantor and all other proper charges and disbursements of the Trustee, shall be paid from the Fund.

Section 10. Annual Valuation

The Trustee shall, annually, at least 30 days prior to the anniversary date of establishment of the Fund, furnish to the Grantor and to the NJDEP a statement confirming the value of the Trust. Any securities in the Fund shall be valued at market value as of no more than 60 days prior to the anniversary date of establishment of the Fund. The failure of the Grantor to object in writing to the Trustee within 90 days after the statement has been furnished to the Grantor and the NJDEP shall constitute a conclusively binding assent by the Grantor, barring the Grantor from asserting any claim or liability against the Trustee with respect to matters disclosed in the statement.

Section 11. Advice of Counsel

The Trustee may, from time to time, consult with counsel, who may be counsel to the Grantor, with respect to any question arising as to the construction of this Agreement or any action to be taken hereunder. The Trustee shall be fully protected, to the extent permitted by law, in acting upon the advice of counsel.

Section 12. Trustee Compensation

The Trustee shall be entitled to reasonable compensation, from time to time, for its services, as agreed upon in writing with the Grantor.

Section 13. Successor Trustee

The Trustee may resign or the Grantor may replace the Trustee, but such resignation or replacement shall not be effective until the Grantor has appointed a successor trustee and this successor accepts the appointment. The successor trustee shall have the same powers and duties as those conferred upon the Trustee hereunder. Upon the successor trustee's acceptance of the appointment, the Trustee shall assign, transfer and pay over to the successor Trustee the funds and properties constituting the Fund. If for any reason, the Grantor cannot or does not act in the event of the resignation of the Trustee, the Trustee may apply to a court of competent jurisdiction for the appointment of a successor Trustee or for instructions. The successor trustee shall specify the date on which it assumes administration of the trust in writing sent to the Grantor, the NJDEP and the present Trustee by certified mail 10 days before such change becomes effective. Any expenses incurred by the Trustee as a result of any of the acts contemplated by this Section shall be paid as provided in Section 9.

Section 14. Successor Grantor

Sixty days prior to the Grantor ceasing to exist, if dissolution is contemplated, the Grantor must notify and provide NJDEP with the names and addresses of any and all successors and assigns along with a notarized acknowledgment from same stating that the successors and assigns assume responsibilities concerning financial assurance.

Section 15. Instructions to the Trustee

All orders, requests and instructions by the Grantor to the Trustee shall be in writing, signed by such persons as are designated in Attachment B or such other designees as the Grantor may designate by amendment to Attachment B. The Trustee shall be fully protected in acting without inquiry in accordance with the Grantor's orders, requests and instructions. All orders, requests and instructions by the NJDEP to the Trustee shall be in writing, signed by the NJDEP Commissioner or his/her designee and the Trustee shall act and shall be fully protected in acting in accordance with such orders, requests and instructions. The Trustee shall have the right to assume, in the absence of written notice to the contrary, that no event constituting a change or a termination of the authority of any person to act on behalf of the Grantor or NJDEP hereunder has occurred.

The Trustee shall have no duty to act in the absence of such orders, requests and instructions from the Grantor and/or NJDEP, except as provided for herein.

Section 16. Amendment of Agreement

This agreement may be amended by an instrument in writing executed jointly by the Grantor or the Grantor's principals, successors, and assigns if Grantor has dissolved, the Trustee and the NJDEP or by the Trustee and the NJDEP if the Grantor ceases to exist and no successors or assigns are named.

Section 17. Irrevocability and Termination

Subject to the right of the parties to amend this Agreement, as provided in Section 16, this Trust shall be irrevocable and shall continue until terminated at the written agreement of the Grantor, the Trustee and the NJDEP or of the Trustee and the NJDEP, if the Grantor ceases to exist. Upon termination of the Trust, all remaining trust property, less final trust administration expenses, shall be delivered to the Grantor.

Section 18. Immunity and Indemnification

The Trustee shall not incur personal liability of any nature in connection with any act or omission, made in good faith, in the administration of this Trust or in carrying out any directions by the Grantor or the NJDEP issued in accordance with the Agreement. The Trustee shall be indemnified and saved harmless by the Grantor or from the Trust Fund, or both, from and against any personal liability to which the Trustee may be subjected by reason of any act or conduct in its official capacity, including all expenses reasonably incurred in its defense in the event that the Grantor fails to provide such defense.

Section 19. Choice of Law

This Agreement shall be administered, construed and enforced according to the laws of the State of New Jersey.

Section 20. Interpretation

As used in this Agreement, words in the singular include the plural and words in the plural include the singular.

The descriptive headings for each Section of this Agreement shall not affect the interpretation or the legal efficacy of this Agreement.

In Witness Whereof, the parties have caused this Agreement to be executed by their respective officer or management officials, duly authorized, and their corporate seals to

be hereunto affixed and attested, as of the date set forth below:

[NAME OF GRANTOR]
DATE: _____ BY: _____
TITLE: _____

[NAME OF TRUSTEE]
DATE: _____ BY: _____
TITLE: _____

[Grantor shall attach Attachments A and B.]

CERTIFICATION OF ACKNOWLEDGMENT

A certification of acknowledgment required by N.J.A.C. 7:14-8.4(a) shall be worded as follows, except that instructions in brackets are to be replaced with the relevant information and the brackets deleted.

CERTIFICATION OF ACKNOWLEDGMENT

(Grantor & Trustee)

ADJUDICATORY HEARING REQUEST

NOTICE OF CIVIL ADMINISTRATIVE

ASSESSMENT DATED [date]

NAME OF VIOLATOR _____

ADDRESS OF VIOLATOR _____

ADDRESS OF SITE OR FACILITY AT WHICH VIOLATION OCCURRED _____

Amount of Financial Guarantee \$ _____

Type of Financial Assurance Posted _____

State of _____

County of _____

On this [date], before me personally came [name of the violator] to me known, who, being by me duly sworn, did depose and say that she/he resides at [address], that she/he is [title] of [corporation], the corporation described in and which executed the above instrument; that she/he knows the seal of the corporation; that the seal affixed to such instruments is such corporate seal; that is so affixed by order of the Board of Directors of the corporation, and that she/he signed her/his name thereto by like other.

[Signature of Notary Public]

New Rule, R.1991 d.378, effective August 5, 1991.
See: 23 N.J.R. 1089(a), 23 N.J.R. 2366(a).