

# NEW JERSEY REGISTER



0100330  
EDUCATION, DEPARTMENT OF  
DIV LIBRARY, ARCHIVES, & HISTORY  
CN 520  
TRENTON NJ 08625 INTER-OFFICE 9

## THE JOURNAL OF STATE AGENCY RULEMAKING

VOLUME 21 NUMBER 17  
September 5, 1989 Indexed 21 N.J.R. 2691-2842  
(Includes adopted rules filed through August 14, 1989)

**MOST RECENT UPDATE TO NEW JERSEY ADMINISTRATIVE CODE: JUNE 19, 1989**  
See the Register Index for Subsequent Rulemaking Activity.

**NEXT UPDATE: SUPPLEMENT JULY 17, 1989**

### RULEMAKING IN THIS ISSUE

#### RULE PROPOSALS

|   |             |
|---|-------------|
| <b>Interested persons comment deadline</b> .....  | <b>2692</b> |
| <b>ADMINISTRATIVE LAW</b>   |             |
| Special education hearings; nonlawyer representation .....  | 2693(a)     |
| <b>COMMUNITY AFFAIRS</b>  |             |
| Uniform Construction Code: educational facility<br>use group .....                                      | 2783(a)     |
| Barrier Free Subcode .....  | 2774(a)     |
| <b>EDUCATION</b>  |             |
| Certification of bilingual and ESL teachers .....   | 2721(a)     |
| Provisional certification of first-year teachers .....  | 2717(a)     |
| Pupil transportation .....  | 2724(a)     |
| <b>ENVIRONMENTAL PROTECTION</b>   |             |
| Hazardous and solid waste management: civil<br>administrative penalties and adjudicatory hearings ..... | 2734(a)     |
| <b>HEALTH</b>   |             |
| Local boards of health: basic educational program<br>concerning HIV infection .....                     | 2696(a)     |
| <b>HIGHER EDUCATION</b>   |             |
| Evaluation of community college presidents .....  | 2697(a)     |
| <b>HUMAN SERVICES</b>   |             |
| State psychiatric facilities: transfers of involuntarily<br>committed patients .....                    | 2751(a)     |
| Long Term Care Services Manual .....  | 2752(a)     |
| Long-term care facilities: preproposal concerning<br>pre-admission screening of Medicaid patients ..... | 2773(a)     |
| Commission for the Blind and Visually Impaired:<br>operations and procedures .....                      | 2753(a)     |
| <b>INSURANCE</b>  |             |
| Medical Malpractice Reinsurance Recovery Fund<br>surcharge .....  | 2698(a)     |
| <b>LABOR</b>  |             |
| Unemployment Compensation and State Plan Temporary<br>Disability: 1990 rates .....                      | 2700(a)     |

|  |         |
|--|---------|
| Workers' Compensation: 1990 maximum rates .....                                    | 2701(a) |
| <b>LAW AND PUBLIC SAFETY</b>   |         |
| Audiology and speech-language pathology: licensure<br>and practice .....           | 2702(a) |
| <b>PUBLIC UTILITIES</b>  |         |
| Annual filing of customer lists by solid waste collectors;<br>annual reports ..... | 2702(b) |
| Earned return analysis of utility rates: extension of<br>comment period .....      | 2704(a) |
| Solid waste uniform tariff .....   | 2704(b) |
| <b>TRANSPORTATION</b>  |         |
| Right-of-way acquisitions .....  | 2713(a) |
| Bridge Rehabilitation and Improvement Bond Act rules ...                           | 2716(a) |

#### RULE ADOPTIONS

|   |         |
|---|---------|
| <b>BANKING</b>  |         |
| Check cashing facilities: administrative correction to<br>N.J.A.C. 3:24-5.1 ..... | 2784(a) |
| <b>EDUCATION</b>  |         |
| Substance abuse control and education .....                                       | 2784(b) |
| Statewide assessment of pupil proficiency in core studies ..                      | 2786(a) |
| <b>ENVIRONMENTAL PROTECTION</b>   |         |
| Reduction of privilege to withdraw water: notice of rule<br>invalidity .....      | 2786(b) |
| <b>HEALTH</b>   |         |
| Hospital reimbursement: adjusted admission fee ceiling .....                      | 2787(a) |
| Hospital reimbursement: rates adjustment and<br>reconciliation .....              | 2787(b) |
| <b>HIGHER EDUCATION</b>   |         |
| Educational Opportunity Fund: eligibility for<br>undergraduate grants .....       | 2788(a) |

(Continued on Next Page)

# INTERESTED PERSONS

**Interested persons** may submit, in writing, information or arguments concerning any of the rule proposals in this issue until **October 5, 1989**. Submissions and any inquiries about submissions should be addressed to the agency officer specified for a particular proposal or group of proposals.

On occasion, a proposing agency may extend the 30-day comment period to accommodate public hearings or to elicit greater public response to a proposed new rule or amendment. An extended comment deadline will be noted in the heading of a proposal or appear in a subsequent notice in the Register.

At the close of the period for comments, the proposing agency may thereafter adopt a proposal, without change, or with changes not in violation of the rulemaking procedures at N.J.A.C. 1:30-4.3. The adoption becomes effective upon publication in the Register of a notice of adoption, unless otherwise indicated in the adoption notice. Promulgation in the New Jersey Register establishes a new or amended rule as an official part of the New Jersey Administrative Code.

## RULEMAKING IN THIS ISSUE—Continued

|  |         |   |             |
|--|---------|---|-------------|
| <b>HUMAN SERVICES</b>  |         | <b>EMERGENCY ADOPTION</b>   |             |
| Medicaid eligibility: administrative correction to<br>N.J.A.C. 10:49-1.1 .....   | 2789(a) | <b>TREASURY-GENERAL/COMMERCE, ENERGY AND<br/>ECONOMIC DEVELOPMENT</b>   |             |
| Child Support Program: incentive payment methodology ..  | 2787(b) | Purchase Bureau rules; small business and urban<br>development enterprises; minority and female<br>subcontractors .....             | 2810(a)     |
| Food Stamp Program revisions .....   | 2790(a) |   |             |
| <b>CORRECTIONS</b>   |         | <b>PUBLIC NOTICES</b>   |             |
| Recreation and leisure time activities .....   | 2793(a) |   |             |
| <b>INSURANCE</b>   |         |   |             |
| FAIR Plan surcharge .....  | 2796(a) |   |             |
| <b>LABOR</b>   |         | <b>EDUCATION</b>  |             |
| Board of Review: appeals of unemployment benefit<br>determinations .....   | 2797(a) | Public testimony session concerning proposed<br>rule changes .....  | 2822(a)     |
| Unemployment and disability insurance appeals:<br>telephone hearings .....   | 2798(a) | <b>ENVIRONMENTAL PROTECTION</b>   |             |
| Job Training Partnership Act/N.J. Jobs Training Act:<br>grievance procedures .....   | 2799(a) | Monmouth County water quality management:<br>Wall Township .....  | 2822(b)     |
| Public employee safety and health: hazardous waste<br>operations and emergency response .....  | 2800(a) | <b>HUMAN SERVICES</b>   |             |
| Public employee safety and health: work in confined<br>spaces .....  | 2800(b) | Children's Trust Fund grant program for prevention of<br>child abuse and neglect .....  | 2822(c)     |
| <b>LAW AND PUBLIC SAFETY</b>   |         | <b>INSURANCE</b>  |             |
| Inactive dental hygienists: resumption of practice .....   | 2801(a) | Recertification to Legislature: notice of cancellation<br>and nonrenewal of fire and casualty coverage .....                        | 2822(d)     |
| Board of Psychological Examiners: written<br>examination fee .....   | 2801(b) | Municipalities requiring payment of liens by companies<br>writing fire insurance .....  | 2823(a)     |
| Board of Veterinary Medical Examiners .....  | 2801(c) | <b>LAW AND PUBLIC SAFETY</b>  |             |
| <b>PUBLIC UTILITIES</b>  |         | Board of Medical Examiners: petition for rulemaking<br>to authorize practice of physician assistants .....                          | 2824(a)     |
| Telecommunications: Alternative Operator Service (AOS)<br>providers .....  | 2801(d) | Board of Mortuary Science: petition for rulemaking to<br>prohibit removal of human remains prior to<br>pronouncement of death ..... | 2825(a)     |
| <b>TRANSPORTATION</b>  |         | <b>EXECUTIVE ORDER NO. 66(1978)</b>   |             |
| Bureau of Electrical Engineering: release of traffic signal<br>information; drawbridge operations; reimbursed<br>highway safety lighting ..... | 2804(a) | <b>EXPIRATION DATES</b> .....   | <b>2826</b> |
| NJ TRANSIT: availability of public records .....   | 2804(b) |   |             |
| <b>TREASURY-GENERAL</b>  |         | <b>INDEX OF RULE PROPOSALS<br/>AND ADOPTIONS</b> .....  | <b>2831</b> |
| State Health Benefits Program: effective date of coverage ..   | 2807(a) |   |             |
| Common Pension Fund A: investment limitations .....  | 2808(a) |   |             |
| <b>PUBLIC EMPLOYMENT RELATIONS COMMISSION</b>  |         |   |             |
| Rulemaking petitions .....   | 2808(b) |   |             |
| <b>CASINO CONTROL COMMISSION</b>   |         |   |             |
| Section 99 submissions .....   | 2808(c) |   |             |

(Continued on page 2842)

## NEW JERSEY REGISTER

The official publication containing notices of proposed rules and rules adopted by State agencies pursuant to the New Jersey Constitution, Art. V, Sec. IV, Para. 6 and the Administrative Procedure Act, N.J.S.A. 52:14B-1 et seq. Issued monthly since September 1969, and twice-monthly since November 1981.

Material published in the New Jersey Register is the property of the State of New Jersey. However, it may be copied, reproduced or republished by any person for any purpose whatsoever without permission, providing that no such reproduction or republication shall bear the title "New Jersey Register" or "Official Rules Publication" without the written permission of the Director, Office of Administrative Law.

The New Jersey Register (ISSN 0300-6069) is published the first and third Mondays (Tuesday, if Monday is a holiday) of each month by OAL Publications of the Office of Administrative Law, CN 301, Trenton, New Jersey 08625. Telephone: (609) 588-6606. Subscriptions, payable in advance, are one year, \$75 (\$150 by First Class Mail); back issues when available, \$8 each. Make checks payable to OAL Publications.

POSTMASTER: Send address changes to: New Jersey Register, CN 301, Trenton, New Jersey 08625. Second Class Postage paid in South Plainfield, New Jersey.

*The NEW JERSEY ADMINISTRATIVE CODE is published on a continuing basis by OAL Publications of the Office of Administrative Law. Subscription rates for this 42-volume, regularly updated set of State administrative rules are available on request. The Code is sold either in the full set or in one to four volumes depending on the Department coverage desired.*

# RULE PROPOSALS

## ADMINISTRATIVE LAW

### (a)

#### OFFICE OF ADMINISTRATIVE LAW

#### Special Hearing Rules

#### Special Education Program

#### Uniform Administrative Procedure Rules

#### Representation by Non-lawyers

#### Proposed Repeal and New Rules: N.J.A.C. 1:6A

#### Proposed Amendment: N.J.A.C. 1:1-5.4

Authorized By: Jaynee LaVecchia, Director, Office of Administrative Law.

Authority: N.J.S.A. 52:14F-5(e), (f) and (g).

Proposal Number: PRN 1989-443.

Submit comments by October 5, 1989 to:

Steven L. Lefelt, Deputy Director  
Office of Administrative Law  
Quakerbridge Plaza, Bldg. 9  
Quakerbridge Road, CN 049  
Trenton, NJ 08625

The agency proposal follows:

#### Summary

On May 15, 1988, the Department of Education revised its special education program rules, N.J.A.C. 6:28, at 21 N.J.R. 1385(a) (May 15, 1988). These proposed new rules and amendment conform the Office of Administrative Law (OAL) special education rules to the Department's revised rules. Proposed for repeal are the existing OAL special education rules because several sections of the existing rules were to be deleted and the OAL wished to conform the chapter to the organizational structure of other OAL special rules. The existing rules were repealed to make the entire proposal more readable.

Except for the proposed changes to representation by "lay advocates," discussed below, most of the proposed new rules do not significantly alter existing practice. For example, proposed for repeal are the current N.J.A.C. 1:6A-2.1 and 1:6A-2.2(a) to (d). These rules deal with the procedure which must be followed by the parents and local school boards up to and including the hearing request. This part of the process falls within the jurisdiction of the Department of Education, Division of Special Education, and has been incorporated into the Department's rules. Therefore, the proposed repeals eliminate these duplicative provisions from the OAL rules.

The Department of Education's rules were designed to emphasize the voluntariness of the mediation which is conducted by the Division of Special Education. The proposed new rules mirror this change. The proposed new rules also delete an adjournment provision from the existing rules since the Department's rules no longer permit such adjournments. The proposed new rules change "settlement conference" references to "conference" because that is the new Division of Special Education term.

The proposed new rules indicate that prehearing conferences will not be scheduled in special education cases and that parents have the right to open the evidentiary hearing to the public and to have the child who is the subject of the hearing present. These have been the OAL practices; however, they were not specifically set forth in the previous rules.

The proposed new rules also clarify several provisions so that they more clearly conform with Federal law requirements. Proposed N.J.A.C. 1:6A-9.1, for example, provides that a hearing date later than 14 days from the conference must be approved by a judge (see 34 C.F.R. 300.512(c)). Proposed N.J.A.C. 1:6A-14.3 and 18.1 indicate that any adjournment must be for a specified period of time (see 34 C.F.R. 300.512(c)). Proposed N.J.A.C. 1:6A-18.1 more clearly indicates that decisions must be issued no later than 45 days from the hearing request.

A major change in these proposed new rules involves representation of parents by "lay advocates", as non-lawyers are called in special education cases. Proposed new rule N.J.A.C. 1:6A-5.1 and the proposed amendment to N.J.A.C. 1:1-5.4 are required because of the Third Circuit Court of Appeals decision in *Arons v. New Jersey Board of Education*,

842 F.2d 58 (3rd Cir. 1988). In that opinion, 20 U.S.C. 1415(d)(1) was interpreted to allow educational specialists ("lay advocates") to assist parents, but the Court could not find any support in the legislative history authorizing individuals with special knowledge to act as representatives of parents at administrative hearings. Thus, lay advocates no longer meet the dictates of R.1:21-1(e) since their right to represent parents is not "required by federal law." Therefore, these non-lawyers no longer qualify under N.J.A.C. 1:1-5.4(a)1.

After the Third Circuit's decision in *Arons v. New Jersey Board of Education*, the OAL believes that non-lawyers representing parents at OAL hearings may be committing the unauthorized practice of law. Unless the Supreme Court amends R.1:21-1(e), the OAL sees no legal alternative but to adopt this proposed new rule and amendment. The Attorney General's office has advised the OAL that it fully agrees with the OAL's assessment of the existing law.

This proposed new rule and amendment, therefore, restricts non-lawyers in special education hearings to assistance functions. The new rule and amendment attempt to specify those assistance functions that are permitted and those representation functions that if performed by non-lawyers would be the unauthorized practice of law. Education specialists may, for example, help parents negotiate settlements, testify for parents, consult with parents, advise parents about educational decisions and serve subpoenas for parents. The specialists, however, cannot draft or sign documents for parents or make appearances in administrative proceedings outside the parents' presence. Education specialists may perform representational services at the hearing only on a limited, restricted basis when the judge finds that it is necessary to assist a parent in making a particular point or presenting a piece of evidence. The new rule and amendment make clear that the education specialist cannot present a parent's case to the OAL. A parent appearing without a lawyer but with an education specialist will be responsible for presenting his or her own case to the administrative law judge.

#### Social Impact

Since the proposed new rules conform OAL's rules with those of the Department of Education, confusion and potential litigation should be eliminated. The new codification of OAL's special education rules should make them easier to follow and to find applicable provisions in the Uniform Administrative Procedure Rules, N.J.A.C. 1:1.

Proposed new rule N.J.A.C. 1:6A-5.1 and the amendment to N.J.A.C. 1:1-5.4 explain all limitations placed upon non-lawyers (lay advocates) in special education cases by 10 U.S.C. 1415(d)(1) as interpreted by *Arons v. New Jersey Board of Education*. Clarification of the rules may result in more parents of special education children being helped by education specialists during an administrative hearing because of less fear on the part of the education specialists that they must provide trial practice services. Under proposed new rule N.J.A.C. 1:6A-5.1, presentation of a special education case becomes the responsibility of the parent. Some parents may have to retain lawyers if they feel they cannot adequately represent themselves, with the assistance of an education specialist.

#### Economic Impact

Some unnecessary expense that would be caused by confusion between OAL and Department rules and potential litigation over different terminology should be eliminated by the proposed new rules which conform the rules. The Third Circuit Court of Appeals in *Arons v. New Jersey Board of Education*, 842 F.2d 58 (3rd Cir. 1988) clarified what charges may be assessed by those persons assisting under 20 U.S.C. 1415(d)(1). New rule N.J.A.C. 1:6A-5.1 does not further regulate permitted charges. This rule may require some parents of special education children to hire attorneys if they choose not to represent themselves with the assistance of an education specialist.

#### Regulatory Flexibility Analysis

Requiring non-lawyers to assist rather than represent parents in special education cases may indirectly impact upon small businesses, such as the Parent Information Center of New Jersey, Inc. and other parent support groups which house "lay advocates" in New Jersey. Besides the Parent Information Center, the OAL is unaware of the names of any other similar small businesses. Under proposed N.J.A.C. 1:6A-5.1, the types of services provided to parents by these small businesses will be restricted to assistance instead of representation at the hearing. To the OAL's knowledge, there are no "lay advocate" groups that are not small businesses under the statutory definition.

This rule does not establish differing compliance or reporting requirements or timetables that take into account the resources available to these small businesses. This rule simply requires lay advocates to perform in a certain manner at special education hearings. It does not impose any expense, reporting, recordkeeping or other such requirements on these small businesses. In fact, to the extent that the prior practice required lay advocates to complete Notices of Appearance/Application forms under N.J.A.C. 1:1-5.4, this amendment removes this requirement. There should be no adverse economic impact on these small businesses as a result of this rule change because even under the prior rules lay advocates were precluded from charging for representing parents at OAL hearings.

Beyond the effects of N.J.A.C. 1:6A-5.1 and 1:1-5.4 as described above, the proposed new rules impose no reporting, recordkeeping or compliance requirements on small businesses.

Full text of the proposed repeal may be found in the New Jersey Administrative Code at N.J.A.C. 1:6A.

Full text of the proposed new rules and proposed amendment follows (additions indicated in boldface thus; deletions shown in brackets [thus]):

1:1-5.4 Representation by non-lawyers; authorized situations, applications, approval procedures

(a) (No change.)

(b) The non-lawyer applicants in (a) above may apply for permission to appear by supplying the following information and by complying with the following procedures:

1. (No change.)

2. A written Notice of Appearance/Application on forms supplied by the Office of Administrative Law shall be required in cases where a non-lawyer employee seeks to represent a State agency; in Civil Service cases, where a union representative seeks to represent a State, county or local government employee; [where a non-lawyer seeks to represent a party in a special education hearing;] where a principal seeks to represent a close corporation, and where a non-lawyer from a legal services program seeks to represent an indigent. A non-lawyer from a legal services program seeking to represent a recipient or applicant for services in Division of Public Welfare, Division of Medical Assistance and Health Services and Division of Youth and Family Services cases may make oral application to represent the recipient or applicant by complying with the requirements of (b)1 above.

i.-iii. (No change.)

iv. [In special education hearings the non-lawyer applicant shall include in his or her Notice an explanation of how he or she satisfies the Federal and State requirements for non-lawyer representation.] (Reserved).

v.-viii. (No change.)

CHAPTER 6A  
SPECIAL EDUCATION PROGRAM

CROSS REFERENCE (Old to New)

| Old Citation        | New Citation | Old Citation | New Citation |
|---------------------|--------------|--------------|--------------|
| 1:6A-1.1            | 1:6A-1.1     | 1:6A-4.1     | 1:6A-14.1    |
| 1:6A-2.1            | Repealed     | 1:6A-4.2     | 1:6A-5.1     |
| 1:6A-2.2(a)-(d)     | Repealed     | 1:6A-4.3     | 1:6A-14.2    |
| 1:6A-2.2(e)         | 1:6A-4.1     | 1:6A-4.4     | 1:6A-14.3    |
| 1:6A-3.1            | 1:6A-12.1    | 1:6A-5.1(a)  | Deleted      |
| 1:6A-3.2(a)-(d),(f) | 1:6A-4.2     | 1:6A-5.1(b)  | 1:6A-18.1    |
| 1:6A-3.2(e)         | Repealed     | 1:6A-5.2     | 1:6A-18.2    |
| 1:6A-3.3            | 1:6A-10.1    | 1:6A-5.3     | 1:6A-18.3    |
| 1:6A-3.4            | 1:6A-9.1     | 1:6A-5.4     | 1:6A-18.4    |
| 1:6A-3.5            | 1:6A-4.3     | 1:6A-5.5     | 1:6A-18.5    |

CROSS REFERENCE (New and Old)

| New Citation | Old Citation | New Citation | Old Citation |
|--------------|--------------|--------------|--------------|
| 1:6A-1.1     | 1:6A-1.1     | 1:6A-13.1    | New Section  |
| 1:6A-4.1     | 1:6A-2.2(e)  | 1:6A-14.1    | 1:6A-4.1     |
| 1:6A-4.2     | 1:6A-3.2     | 1:6A-14.2    | 1:6A-4.3     |
| 1:6A-4.3     | 1:6A-3.5     | 1:6A-14.3    | 1:6A-4.4     |
| 1:6A-5.1     | 1:6A-4.2     | 1:6A-18.1    | 1:6A-5.1(b)  |
| 1:6A-9.1     | 1:6A-3.4     | 1:6A-18.2    | 1:6A-5.2     |
| 1:6A-10.1    | 1:6A-3.3     | 1:6A-18.3    | 1:6A-5.3     |
| 1:6A-12.1    | 1:6A-3.1     | 1:6A-18.4    | 1:6A-5.4     |
|              |              | 1:6A-18.5    | 1:6A-5.5     |

SUBCHAPTER 1. APPLICABILITY

1:6A-1.1 Applicability

(a) The rules in this chapter shall apply to the notice and hearing of matters arising out of the Special Education Program of the Department of Education, pursuant to N.J.A.C. 6:28. Any aspect of notice and hearing not covered by these special hearing rules shall be governed by the Uniform Administrative Procedure Rules (U.A.P.R.) contained in N.J.A.C. 1:1. To the extent that these rules are inconsistent with the U.A.P.R., these rules shall apply.

(b) These rules are established in implementation of Federal law, at 20 U.S.C.A. 1415 et seq. and 34 CFR 300 et seq. These rules do not duplicate each provision of Federal law, but highlight some of the key Federal provisions which form the source or authority for these rules. Where appropriate, the Federal source or authority for a rule or Federal elaboration of a rule will be indicated in brackets following the rule. In any case where these rules could be construed as conflicting with Federal requirements, the Federal requirements shall apply.

(c) Since these rules are established in implementation of Federal law, they may not be relaxed except as specifically provided herein or pursuant to Federal law.

SUBCHAPTER 2. (RESERVED)

SUBCHAPTER 3. (RESERVED)

SUBCHAPTER 4. AGENCY RESPONSIBILITY BEFORE TRANSMISSION TO THE OFFICE OF ADMINISTRATIVE LAW

1:6A-4.1 Notice of available legal service

(a) In its acknowledgement of a hearing request, the Department of Education shall inform the parties of any free or low-cost legal and other relevant services available, including:

1. The Division of Advocacy for the Developmentally Disabled in the Department of the Public Advocate;
2. The New Jersey State Bar Association and county bar association lawyer referral services;
3. The Association of Trial Lawyers—New Jersey lawyer referral service; and
4. The Legal Aid and Legal Services offices in New Jersey (34 CFR 300.506(c)).

1:6A-4.2 Conference by the Department of Education

(a) Within seven days of receipt of any hearing request, the Department of Education shall conduct a conference at a time and place convenient to both parties.

(b) The purpose of the conference is to assist the parties in defining issues, identifying evidence, exchanging information, stipulating facts and listing possible witnesses for a hearing. Mediation will be available at the conference if both parties agree to participate.

(c) If a settlement is reached, the terms shall be reduced to writing and signed by the parties and the representative of the Department of Education.

(d) If a settlement is not reached, the Department of Education representative shall prepare a written document at the conference that specifies the issues in dispute, any stipulations, and evidence and witness lists for each party. This document shall be included with the transmittal form and shall be immediately forwarded to the Office of Administrative Law. Copies of the written document and of the transmittal form shall

be sent to the parties. Any exhibits that both parties agree are admissible may be attached to the document.

(e) The Department of Education shall include with the transmittal any unsettled jurisdictional matters, notice problems, or other preliminary motions from the parties.

(f) The board of education or public agency shall ensure that a representative attends the conference. Participation by the parents is voluntary.

#### 1:6A-4.3 Ongoing settlement efforts

(a) The scheduling of a hearing shall not preclude voluntary ongoing efforts by the parties to settle the matter before or at the hearing.

(b) Any ongoing settlement efforts by the parties shall not delay, interfere with, or otherwise impede a request for a hearing or the progress thereof, nor be grounds for adjournment of a hearing, unless a party requests an adjournment and the judge approves the adjournment to a specific date. Any such adjournment shall extend the deadline for decision, as established in N.J.A.C. 1:6A-18.1, Deadline for decision, by an amount of time equal to the adjournment.

### SUBCHAPTER 5. REPRESENTATION

#### 1:6A-5.1 Representation by lawyers and assistance by education specialists

(a) At a special education proceeding, any parent may be represented by a lawyer and/or assisted by an individual with special knowledge or training with respect to handicapped pupils and their educational needs, or both.

(b) Individuals with special knowledge or training with respect to handicapped pupils and their educational needs may not perform any assistance outside of the parents' presence and may not prepare any documents or sign any documents for parents, except for expert witness reports. These education specialists may testify for parents, serve subpoenas for parents, consult with parents, help parents negotiate settlements and advise parents about educational decisions. These specialists, however, may not make oral arguments, present evidence, cross-examine witnesses, make objections or otherwise perform representational services at the evidentiary hearing, unless the judge finds that it is necessary to permit the performance of some of these functions on a limited, restricted basis in order to assist a parent in making a particular point or presenting a piece of evidence.

### SUBCHAPTERS 6, 7 and 8. (RESERVED)

### SUBCHAPTER 9. SCHEDULING

#### 1:6A-9.1 Scheduling of hearing by Office of Administrative Law

If the matter is not fully resolved at the conference, as required in N.J.A.C. 1:6A-4.2, the representative of the Department at the conference shall, in the presence of the parties, telephone the Clerk of the Office of Administrative Law and the Clerk shall assign a peremptory hearing date. The hearing date shall, to the greatest extent possible, be convenient to all parties but shall be no later than 14 days from the date of the conference, unless a later date is agreed upon by all parties and approved by a judge. If a later date is agreed upon, the deadline for decision, as established in N.J.A.C. 1:6A-18.1, shall be extended by a time equal to the amount of delay. The Commissioner of Education shall, no later than three days after the conference, transmit the matter to the Office of Administrative Law. Copies of all notices, requests, pleadings, filings, stipulations of issues and facts, evidence and witness lists compiled at the conference and a description of the positions of each party shall be included with the standard Office of Administrative Law transmittal form required by N.J.A.C. 1:1-8.2.

### SUBCHAPTER 10. DISCOVERY

#### 1:6A-10.1 Discovery

(a) All requests for information, records or other discovery shall be made before or at the conference. All responses to these requests shall be completed no later than five days before the date of the hearing.

(b) Each party shall disclose to the other party any documentary evidence and summaries of testimony intended to be introduced at the hearing.

(c) Upon application of a party the judge shall exclude any evidence at hearing that has not been disclosed to that party at least five days before the hearing, unless the judge determines that the evidence could not reasonably have been disclosed within that time.

(d) Discovery shall to the greatest extent possible consist of the informal exchange of questions and answers and other information. Discovery may not include requests for formal interrogatories, formal admissions or depositions.

### SUBCHAPTER 11. (RESERVED)

### SUBCHAPTER 12. MOTIONS

#### 1:6A-12.1 Emergency relief pending settlement or decision

(a) As part of a hearing request, or at any time after a hearing is requested, the affected parent(s), guardian, board or public agency may apply in writing for emergency relief pending a settlement or decision on the matter. An emergency relief application shall set forth the specific relief sought and the specific circumstances which the applicant contends justifies under (e) below the relief sought. Each application shall be supported by an affidavit prepared by an affiant with personal knowledge of the facts contained therein and, if an expert's opinion is included, the affidavit shall specify the expert's qualifications.

(b) Prior to the transmittal of the hearing request to the Office of Administrative Law, applications for emergency relief shall be addressed to the Department of Education, attention Division of Special Education, with a copy to the other party. The Department shall forward to the Office of Administrative Law by the end of the next business day all emergency relief applications that meet the procedural requirements in (a) above and which set forth on the face of the application and affidavits circumstances which would justify emergency relief under this section. Emergency relief applications which show no right to emergency relief or fail to comply with the procedural requirements shall be processed by the Department in accordance with N.J.A.C. 1:6A-4.2.

(c) After transmittal, applications for emergency relief must be made to the Office of Administrative Law, with a copy to the other party.

(d) The Office of Administrative Law shall schedule an emergency relief application hearing on the earliest date possible and shall notify all parties of this date. Except for extraordinary circumstances established by good cause, no adjournments shall be granted but the opponent to an emergency relief application may be heard by telephone on the date of the emergency relief hearing. If emergency relief is granted without all parties being heard, provision shall be made in the order for the absent parties to move for dissolution or modification on two days' notice. Such an order, granted without all parties being heard, may also provide for a continuation of the order up to 10 days.

(e) At the emergency relief hearing, the judge may allow the affidavits to be supplemented by testimony and/or oral argument. The judge may order emergency relief if the judge determines from the proofs that:

1. The applicant has a reasonable probability of ultimately prevailing on the merits;

2. Either serious physical harm will result to a student or students if the relief is not granted, or the student's education program will be terminated or interrupted; and

3. The relief requested is narrowly defined to prevent the specific harm from occurring and will not cause unreasonable expense and substantial inconvenience.

(f) Judges may decide emergency relief applications orally on the record and may direct the prevailing party to prepare an order embodying the decision. If so directed, the prevailing party shall promptly mail the order to the judge and shall mail copies to every other party in the case. Unless a party notifies the judge and the prevailing party of his or her specific objections to the order within five days after such service, the judge may sign the order.

(g) After granting or denying the requested emergency relief, the judge shall either return the parties to the Department of Education for a conference under N.J.A.C. 1:6A-4.2 or schedule hearing dates if a conference has already been conducted.

## SUBCHAPTER 13. PREHEARING CONFERENCES

## 1:6A-13.1 Prehearing conferences

Prehearing conferences shall not be scheduled in special education hearings.

## SUBCHAPTER 14. CONDUCT OF CASES

## 1:6A-14.1 Procedures for hearing

(a) To the greatest extent possible, the hearing shall be conducted at a time and place convenient to the parent(s) or guardian.

(b) At the hearing, parents shall have the right to open the hearing to the public, and to have the child who is the subject of the hearing present.

(c) For good cause shown on the record, the judge may adjourn the hearing for a specified time, and the deadline for decision, as established in N.J.A.C. 1:6A-18.1, Deadline for decision, will be extended by an amount of time equal to the adjournment.

(d) A verbatim record shall be made of the hearing.

(e) The judge's decision shall be based on the preponderance of the credible evidence, and the proposed action of the board of education or public agency shall not be accorded any presumption of correctness.

## 1:6A-14.2 Interpreters

Where necessary, the judge may require the Department of Education to provide an interpreter at the hearing or written translation of the hearing, or both, at no cost to the parent(s) or guardian.

## 1:6A-14.3 Independent educational evaluation

(a) For good cause and after giving the parties an opportunity to be heard, the judge may order an independent educational evaluation of the pupil. The evaluation shall be conducted in accordance with N.J.A.C. 6:28-1 by an appropriately certified or licensed professional examiner(s) who is not employed by and does not routinely provide evaluations for the board of education or public agency responsible for the education of the pupil to be evaluated. The independent evaluator shall be chosen either by agreement of the parties or, where such agreement cannot be reached, by the judge after consultation with the parties. The judge shall order the board of education or public agency to pay for the independent educational evaluation at no cost to the parent(s) or guardian. (34 CFR 300.503)

(b) Where an independent educational evaluation is ordered, the judge upon the request of a party may adjourn the hearing for a specified period of time and the deadline for decision, as established in N.J.A.C. 1:6A-18.1, will be extended by an amount of time equal to the adjournment.

## SUBCHAPTERS 15, 16 and 17. (RESERVED)

## SUBCHAPTER 18. DECISION AND APPEAL

## 1:6A-18.1 Deadline for decision

Subject to any adjournments for a specified period of time, the judge shall issue a written decision no later than 45 days from the date of the hearing request.

## 1:6A-18.2 Confidentiality

(a) In a written decision, the judge shall use initials rather than full names when referring to the child and the parent(s) or guardian, and may take other necessary and appropriate steps, in order to preserve their interest in privacy.

(b) Records of special education hearings shall be maintained in confidence by the Office of Administrative Law pursuant to Federal regulations, 34 CFR 300.500 et seq. The Clerk of the Office of Administrative Law, 185 Washington Street, Newark, NJ 07102, (201) 648-6006, shall maintain these records.

## 1:6A-18.3 Appeal, use of hearing record, obtaining copy of record, and contents of record

(a) Any party may appeal the decision of the judge either to the Superior Court of New Jersey, pursuant to the Rules Governing the Courts of the State of New Jersey, or to a district court of the United States, pursuant to 20 U.S.C.A. 1415(e)(3).

(b) A party intending to appeal the administrative law judge's decision or an authorized representative is permitted to use, or may request a certified copy of, any portion or all of the original record of the administrative proceeding, provided a copy remains on file at the Office of Administrative Law. The requesting party shall bear the cost of any necessary reproduction. Written requests for this material should be directed to Decision Control, Office of Administrative Law, 185 Washington Street, Newark, NJ 07102.

(c) The record shall consist of all documents transmitted by the Department of Education to the Office of Administrative Law; correspondence; any documents relating to motions; briefs; exhibits; transcripts, if any; the administrative law judge's decision; and any other material specifically incorporated into the record by the judge.

## 1:6A-18.4 Stay of implementation

(a) Unless the parties otherwise agree, the educational placement of the pupil shall not be changed prior to the issuance of the decision in the case, pursuant to 34 C.F.R. 300.513.

(b) Where a party appeals any portion of the decision not involving a change in the pupil's educational placement, and upon request by any party, the judge may stay implementation of the decision if immediate implementation would be likely to result in serious harm to the pupil or other pupils in the event that the decision is rejected or modified upon appeal.

## 1:6A-18.5 Motion to reopen hearing

(a) Any party may file with the presiding judge, and serve on each other party, a motion to reopen the hearing no later than 10 days following the issuance of the decision.

(b) The judge may reopen the hearing for reasons of:

1. Mistake, inadvertence, surprise or excusable neglect;
2. Newly discovered evidence which would probably alter the decision and which, by due diligence, could not have been discovered in time for the hearing; or
3. Fraud, misrepresentation or misconduct of another party.

## HEALTH

## (a)

## PUBLIC HEALTH COUNCIL

## Recognized Public Health Activities and Minimum Standards of Performance for Local Boards of Health

## Human Immunodeficiency Virus (HIV) Infection Basic Educational Program

## Proposed New Rule: N.J.A.C. 8:52-4.6

Authorized By: Public Health Council, Milton Prystowsky, M.D., Chairperson.

Authority: N.J.S.A. 26:1A-1 et seq. and N.J.S.A. 26:3A2-13. Proposal Number: PRN 1989-455.

Submit written comments by October 5, 1989 to:  
Dennis P. McDonough, M.P.H.  
Chief, Health Aid Services Program  
Department of Health  
CN 360  
Trenton, NJ 08625-0360

The agency proposal follows:

## Summary

The Public Health Council proposes to mandate that a basic educational program be included in Recognized Public Health Activities and Minimum Standards of Performance for Local Boards of Health in New Jersey, N.J.A.C. 8:52, to help address the problems of AIDS and Human Immunodeficiency Virus (HIV) infection. The HIV epidemic is the most serious of this century; nationally, 85,000 AIDS cases have been reported to date and there are an estimated 1.5 million Americans who are infected with the HIV virus. New Jersey ranks fifth among all states in the country with more than 6,600 reported AIDS cases. It is estimated that 70,000 to 105,000 New Jerseyans are infected with the HIV virus which causes

AIDS and that up to 4,000 new cases will be diagnosed next year. By 1992 it is projected that 25,000 cases of AIDS will have been diagnosed in New Jersey.

If the transmission of HIV is to be controlled and prevented, it is important that each individual be aware of the behavioral factors which significantly increase the risk of acquiring HIV infection. The most current statistics for New Jersey disclose that 57 percent of all AIDS cases diagnosed are intravenous drug users (IVDU's) and 26.7 percent are gay or bisexual men who are not intravenous drug users. New Jersey exceeds the national average in terms of intravenous drug users and females yet has a lower number of gay or bisexual men who do not use drugs intravenously. This epidemic is most seriously felt among the ethnic and minority populations. In New Jersey, Blacks and Hispanics account for 65 percent of all AIDS cases.

Until a vaccine or cure is discovered, the only effective preventive measure for containing this disease is education and behavioral change. The proposed HIV rule identifies a role for local health agencies in providing education. This rule will promote the dissemination of accurate information by local health agencies concerning the modes of HIV transmission as well as the ways to reduce the potential of that transmission. It will also promote a closer working relationship between local health agencies and other community groups and health care providers with regards to formulating and implementing a comprehensive strategy for individuals who are at risk to receive the necessary counseling and testing.

Ninety-two of the 114 local health departments responded to a survey on the proposed rule. Sixty-four of the 92 respondents supported the rule as a core activity with half of the supporting respondents expressing concern over a lack of funding to implement these new regulations. In June, the Executive Committee of the New Jersey Health Officers Association endorsed the proposed HIV rule which was presented before the Public Health Council and approved for publication.

#### Social Impact

The proposed new HIV rule will have a positive effect on all New Jerseyans, especially the minority populations which have been hardest hit by the AIDS epidemic. In New Jersey, the primary reservoirs of the HIV virus are inner city intravenous drug using Blacks, Hispanics and their families. This segment of the population is also at greatest risk for infant mortality, syphilis, gonorrhea, tuberculosis, high blood pressure, heart disease, diabetes and cancer.

This rule will further the Statewide effort to educate these primary target groups and the population at large which utilize the resources of local health agencies. Developing a structured role for local health agencies will strengthen existing efforts to prevent and control HIV infection already set in motion by the State Health Department to meet the multiple challenges this epidemic presents.

#### Economic Impact

The projections for the cost of the HIV epidemic are staggering. National figures estimate that the medical care costs of AIDS are \$60,000 per patient and the cumulative medical cost of AIDS for the nation is projected to be \$3.5 billion for 1989.

Until a vaccine or cure is discovered, the only effective preventive measure for containing this disease is education and behavioral change. The role of local health agencies in the proposed HIV disease standards will be focused primarily on providing education. To assist local health agencies in the implementation of an HIV educational campaign, the State Health Department in conjunction with the New Jersey Health Officers Association developed a standardized slide presentation with a curriculum to provide the needed training for local health personnel at no cost to their agencies. While there has been no increase in the Public Health Priority Funding (PHPF) appropriation to support the implementation of this new activity, local health agencies will be provided the option to utilize their PHPF allocation to support this service. A significant number of health departments surveyed indicated that including the HIV infection activity in minimum standards would not impose a significant financial burden on their agencies since they are currently involved in community HIV education efforts and are reportedly providing many of the proposed services. It should also be noted that those areas determined to have the highest incidence of AIDS and largest number of at risk individuals are already receiving Federal and State monies to provide counselling, education and testing services for their residents.

#### Regulatory Flexibility Statement

The proposed new HIV rule will apply to all local boards of health. Since small businesses are not affected by this rule, a regulatory flexibility

analysis is not required as specified in the New Jersey Regulatory Flexibility Act, N.J.S.A. 52:14B-16 et seq.

Full text of the proposed new rule follows:

#### 8:52-4.6 Human Immunodeficiency Virus (HIV) infection

(a) The local board of health shall administer a planned program to prevent and control HIV infection and shall:

1. Utilizing seroprevalence and case reporting data provided by the Department of Health, identify ways to reach persons at high risk within the community and develop and implement a strategy to disseminate HIV prevention and control information to these groups;
2. Maintain supplies of educational materials to meet information requests on the transmission, prevention and control of HIV;
3. Provide or arrange for other suitable local health education resources (for example, Planned Parenthood, Red Cross) to conduct education programs addressing the epidemiology, prevention and control of HIV to civic and community organizations and occupationally at risk groups utilizing state prepared or equivalent curricula;
4. Provide or arrange for in-service training addressing the epidemiology, prevention and control of HIV to all local health department personnel;
5. Develop and implement a protocol to refer individuals concerned about their HIV status to counseling and testing sites and other health care providers;
6. Refer HIV infected persons and their families seeking services to appropriate provider agencies such as mental health, drug treatment and other social service agencies; and
7. Participate in the planning, development and implementation of a county or regional program to control HIV infection and the progression to AIDS.

## HIGHER EDUCATION

### (a)

#### BOARD OF HIGHER EDUCATION

#### County Community Colleges

#### Presidential Contracts

#### Periodic Evaluation of Presidents

#### Proposed New Rule: N.J.A.C. 9:4-7.6

Authorized By: Board of Higher Education, T. Edward Hollander, Chancellor and Secretary.

Authority: N.J.S.A. 18A:64A-7, N.J.S.A. 18A:64A-12 and N.J.S.A. 18A:3-14(h).

Proposal Number: PRN 1989-462.

Submit comments by October 5, 1989 to:

Grey J. Dimenna, Esq.  
Administrative Practice Officer  
Department of Higher Education  
20 West State Street  
CN 542  
Trenton, New Jersey 08625

The agency proposal follows:

#### Summary

This proposed new rule supplements a new rule proposed in the May 15, 1989 New Jersey Register at 21 N.J.R. 1269(a) regarding presidential contracts at county community colleges in New Jersey. This proposed rule adds to the requirements in this area that there be a periodic evaluation of the county college president's performance by the college board of trustees required within such employment contracts.

#### Social Impact

The proposed new rule will help to ensure that renewal of county community college presidential contracts by boards of trustees of those colleges will be based upon an evaluation of the president's past performance at the college and will result in the extension of such contracts based upon the merits of the president.

**Economic Impact**

The proposed new rule has no economic impact as it merely provides for county community colleges to include in presidential contracts a provision for the evaluation of presidential performance on a periodic basis. No significant administrative cost should be involved in such evaluations.

**Regulatory Flexibility Statement**

A regulatory flexibility analysis is not required because the proposed new rule does not impose reporting, recordkeeping or other compliance requirements on small businesses. County community colleges are public institutions.

Full text of the proposal follows:

9:4-7.6 Periodic evaluation of presidents

Presidential employment contracts shall include a provision for periodic evaluation of presidents.

**INSURANCE****(a)****DIVISION OF ADMINISTRATION****New Jersey Medical Malpractice Reinsurance Recovery Fund Surcharge Reproposed New Rules: N.J.A.C. 11:18**

Authorized By: Kenneth D. Merin, Commissioner, Department of Insurance.

Authority: N.J.S.A. 17:1-8.1, N.J.S.A. 17:1C-6(e) and N.J.S.A. 17:30D-1 et seq.

Proposal Number: PRN 1989-467.

A public hearing concerning this rule will be held on Friday, September 22, 1989 at 10:00 A.M. at:

Mary Roebling Building  
Second Floor  
Conference Room 218C  
20 West State Street  
Trenton, NJ 08625

Persons intending to testify at the hearing are required to provide written prior notice of their intention to Verice M. Mason, Assistant Commissioner, Division of Legislative and Regulatory Affairs, Department of Insurance, by the close of business on September 12, 1989. The notice must include a brief summary of the testimony. Testimony will be limited to five minutes.

Persons intending to ask questions at the hearing are requested to provide Assistant Commissioner Mason with their intended questions or areas of interest for questioning by September 12, 1989. Questions may also be permitted from the floor.

The hearing will be conducted in accordance with the provisions of N.J.S.A. 52:14B-4(g).

Submit written comments by October 5, 1989 to:

Verice M. Mason  
Assistant Commissioner  
Legislative and Regulatory Affairs  
New Jersey Department of Insurance  
CN 325  
Trenton, NJ 08625

The agency reproposal follows:

**Summary**

N.J.S.A. 17:30D-1 et seq., the Medical Malpractice Liability Insurance Act ("Act"), was enacted to ensure that medical malpractice liability insurance is readily available to licensed medical practitioners and health care facilities. The Act established the New Jersey Medical Malpractice Reinsurance Association ("Association") which is required to reinsure certain medical malpractice liability insurance policies. The Association is also permitted to write such policies on a direct basis in the absence of a qualified provider willing to issue the needed class of coverage. The Act also established the New Jersey Medical Malpractice Reinsurance Recovery Fund ("Fund") which reimburses the Association for any deficit sustained in its operation.

The Association, although deactivated by 1982, remains obligated on claims presented under the coverage it reinsured or wrote directly during its years of operation. Actuarial studies conducted on behalf of the Association for year end 1982 indicated that the Association would experience substantial deficits and an eventual inability to pay claims on which it was still responsible. The year end actuarial report for 1983 confirmed the existence of a deficit, and the Association has continued to report a deficit to the Department of Insurance ("Department") each year to the present.

In view of the need to fund the Association's deficit, the Department proposed new rules in the August 15, 1988 New Jersey Register (see 20 N.J.R. 2010(a)) which impose a surcharge upon certain classes of physicians and doctors in this State.

Many comments were received concerning the proposed new rules. Most commenters objected to the surcharge because of its application to physicians who did not obtain coverage through the Association. The commenters stressed that those physicians who did not obtain coverage through the Association, but instead obtained coverage in the private market, did not benefit from the creation and operation of the Association and, therefore, should not be surcharged.

The Department disagrees with this assertion. The Association expanded the capacity for medical malpractice insurance, thereby placing downward pressure on the rates charged by insurers in the private market. This dual consequence of the Association's creation (relaxation of capacity and lower private market rates) benefited the total physician population. The same can be said for other categories and subcategories of health care providers for whom the Association was created.

Another commenter asked whether an insurer who was licensed to write medical malpractice insurance, but has not written and does not intend to write such insurance, should nevertheless file annual informational reports pursuant to the proposed new rules. The Department, for reporting purposes, requires all insurers who are licensed to write medical malpractice insurance to submit the reports.

Another commenter objected to the proposed new rules because that commenter believed the proposed new rules were inconsistent with the legislative intent of the Act, and that the proposed new rules are simply unfair.

N.J.S.A. 17:30D-10 states that "For the purpose of providing monies necessary to establish the recovery fund in an amount sufficient to meet the requirements of this act, the Commissioner shall establish reasonable provisions through additional premium charges for policies of the various categories and subcategories of medical malpractice liability insurance." What is clear is that the Legislature left the Commissioner with discretion to assess various policies so that the provisions of the Act may be carried out. The "various" policies the Legislature speaks of are medical malpractice liability insurance policies, leaving the Commissioner the responsibility to determine which of the "various" policies to assess. In light of the present financial condition of the Association, the Commissioner has decided that those health care providers who were able to take advantage of the capacity which the Association brought on must bear a portion of the burden to finance its operation.

A public hearing regarding the proposal was held on October 24, 1988 pursuant to N.J.S.A. 52:14B-4(a)3. Based upon the testimony presented at the hearing, the written materials placed on the record within the required time period, and information from the Department, a hearing officer's report ("report") was submitted to the Commissioner of Insurance ("Commissioner") containing several recommendations.

One of the recommendations in the report suggested hospitals and health maintenance organizations (HMO's) be added to the class of health care providers to which a surcharge should apply because the Association was activated for hospitals and HMO's and a number of such institutions directly benefited by obtaining coverage through the Association.

Another recommendation in the report suggested that the amount of surcharge be assessed against health care providers in the class for which the Association was activated based upon whether the provider was actually insured or reinsured by the Association.

The Commissioner adopted these recommendations. In accordance with the adopted recommendations, the Department repropose new rules in the June 19, 1989 New Jersey Register (see 21 N.J.R. 1642(a)). The repropose new rules published in the June 19 New Jersey Register contained several errors or ambiguities that need to be corrected. Accordingly, the rules as repropose on June 19 are herein repropose with the following changes.

1. A definition of "premium" is provided and the definition of "total premium" is deleted. This change is essentially clarificatory only since

there will be no change in the Department's designation of the premium from which the surcharge is to be collected (see N.J.A.C. 11:18-1.3).

2. The June 19 reproposal inadvertently and contradictorily assessed a surcharge of both five percent and three and thirty-five hundredths percent for HMO's that were insured or reinsured by the Association from 1976 to 1982. As the summary to the repropose rules explained, only the five percent figure was correct. The new reproposal clarifies this matter (see N.J.A.C. 11:18-1.4(a)).

3. The June 19 reproposal imposed a surcharge of three and thirty-five hundredths percent on hospitals that were insured or reinsured by the Association from 1976 to 1982. This figure should be three and seventy-five hundredths percent, as the new reproposal states (see N.J.A.C. 11:18-1.4(b)).

4. An adjustment of surcharge provision is added to reflect changes in the current balance of revenues to expenses (see N.J.A.C. 11:18-1.6).

#### Social Impact

The repropose new rules will allow the Association to remain a viable and stabilizing market influence and to continue to service and pay the claims on which it remains liable. The applicable surcharges affect an estimated 13,800 of the allopathic physician, osteopathic physician, surgeon and podiatrists population in the State, raising the average malpractice premium from \$1 million/\$3 million coverage approximately \$680.00 to \$14,280 for those who were insured or reinsured by the Association from 1976 to 1982 and \$340.00 to \$12,940 for those who were not insured or reinsured by the Association from 1976 to 1982.

The applicable surcharges affect an estimated 96 of the hospitals in the State, raising the average malpractice premium for \$1 million/\$3 million coverage approximately \$11,974 to \$332,000 for those who were insured or reinsured by the Association from 1976 to 1982 and approximately \$8,000 to \$328,000 for those who were not insured or reinsured by the Association from 1976 to 1982.

The applicable surcharges affect an estimated 20 of the health maintenance organizations in the State, raising the average malpractice premium approximately \$3,770 for those who were insured or reinsured by the Association from 1976 to 1982 and \$1,885 for those who were not insured or reinsured by the Association from 1976 to 1982.

#### Economic Impact

The repropose new rules will not result in any significant adverse economic impact upon insurers. Insurers may experience a minimal increase in costs by having to remit the collected surcharges to the State Treasurer and to file biannually with the Department certain specified information.

The insureds who fall within the scope of the repropose new rules will experience an adverse economic impact in that the imposition of the applicable surcharge will result in each insured being responsible for a percent-to-premium charge in excess of the insured's total premium.

There is a possibility that any increase in medical malpractice premiums ultimately will be passed on to the consumers of health care in the State, raising medical costs and continuing the inflationary spiral indicative of the health care environment.

The Department does not expect to incur any additional expenses as a result of the proposed new rules.

#### Regulatory Flexibility Analysis

Some insurers affected by the repropose new rules may be small businesses as that term is defined in the Regulatory Flexibility Act, N.J.S.A. 52:14B-16 et seq. The compliance requirements imposed upon insurers, including small businesses, are that they collect a surcharge only with the policy premium, remit such to the State Treasurer within 10 days from collection and biannually file with the Department specified information regarding the collected and remitted surcharges. None of the above requirements is expected to have any significant adverse economic impact on insurer small businesses. To provide for uniform and consistent applicability of these rules, and to avoid granting any advantage to insurers which are small businesses, no differential treatment is accorded to small business insurers by these repropose new rules.

Full text of the reproposal follows:

## CHAPTER 18

### NEW JERSEY MEDICAL MALPRACTICE REINSURANCE RECOVERY FUND

#### SUBCHAPTER 1. FUND SURCHARGE

##### 11:18-1.1 Purpose

Pursuant to N.J.S.A. 17:30D-9, the New Jersey Medical Malpractice Reinsurance Recovery Fund was created to reimburse the New Jersey Medical Malpractice Reinsurance Association, created pursuant to N.J.S.A. 17:30D-4, for any deficit sustained in the operation of the Association. Pursuant to N.J.S.A. 17:30D-10, the Commissioner is authorized to establish reasonable provisions through additional premium charges for medical malpractice liability insurance policies for the purpose of providing monies necessary to establish the Fund in an amount sufficient to meet the requirements of the Medical Malpractice Liability Insurance Act, N.J.S.A. 17:30D-1 et seq. This subchapter establishes such provisions.

##### 11:18-1.2 Scope

This subchapter applies to all health care providers as defined in this subchapter and to all insurers authorized to write medical malpractice liability insurance in this State.

##### 11:18-1.3 Definitions

The following words and terms, as used in this subchapter, shall have the following meanings, unless the context clearly indicates otherwise:

"Association" means the New Jersey Medical Malpractice Reinsurance Association created pursuant to N.J.S.A. 17:30D-4.

"Commissioner" means the Commissioner of Insurance of the State of New Jersey.

"Fund" means the New Jersey Medical Malpractice Reinsurance Recovery Fund created pursuant to N.J.S.A. 17:30D-9.

"Health care provider" means hospitals, health maintenance organizations, physicians and doctors licensed in this State.

"Medical malpractice liability insurance" means insurance coverage against the legal liability of the insured and against loss, damage or expense incident to a claim arising out of the death or injury of any person as the result of negligence or malpractice in rendering professional service by any physician, doctor, hospital or health maintenance organization, or a claim arising out of ownership, operation or maintenance of the physician's, doctor's, hospital's or health maintenance organization's business premises, including primary and excess coverage.

"Physician" or "doctor" means a doctor of medicine (M.D.), a surgeon, a doctor of osteopathic medicine (D.O.), and a doctor of podiatric medicine (D.P.M.).

"Premium" means the medical malpractice liability insurance premium paid by a health care provider and, in the case of physicians or doctors, includes the portion of the medical malpractice liability insurance premium paid for partnership/association coverage.

"Treasurer" means the Treasurer of the State of New Jersey.

##### 11:18-1.4 Imposition of surcharge

(a) A surcharge of five percent is imposed on the total premiums for all policies of medical malpractice liability insurance covering physicians and doctors presently licensed in New Jersey who were insured (primary or excess) or reinsured by the Association from 1976 to 1982, whether currently practicing individually or as a professional association or employee thereof, or in affiliation or employment with any hospital or health maintenance organization, and those covering health maintenance organizations which were insured (primary or excess) or reinsured by the Association from 1976 to 1982.

(b) A surcharge of three and seventy-five hundredths-percent is imposed on the total premiums for all policies of medical malpractice liability insurance covering hospitals that were insured (primary or excess) or reinsured by the Association from 1976 to 1982.

(c) A surcharge of two and one-half percent is imposed on the total premiums for all policies of medical malpractice liability insurance covering physicians, doctors, hospitals and health maintenance organizations presently licensed in New Jersey who were not insured (primary or excess) or reinsured by the Association from 1976 to 1982.

(d) The applicable surcharge shall apply to all new and renewal policies effective on or after the effective date of this subchapter and to the additional premiums on all endorsements effective on or after the effective date of this subchapter.

(e) The applicable surcharge shall be a separate, up-front charge to the insured in addition to the total premium to be paid, except that in the case of policy premiums paid pursuant to a payment plan or installment plan the applicable surcharge shall be a proportionate charge based upon the payment schedule or amount of payment received. The surcharge shall be shown separately in dollars and cents on each document stating the policy premium. The surcharge shall be identified to the insured as the "Medical Malpractice Reinsurance Recovery Fund Surcharge."

(f) Commissions and premium taxes shall not be payable on the applicable surcharge and the insurer shall be prohibited from absorbing such surcharge as an inducement for insurance or for any other reason.

(g) Failure of the insured to pay the applicable surcharge shall be deemed failure to pay the premium and result in cancellation for nonpayment of premium.

(h) Return of the applicable surcharge collected is permitted on policy activity such as endorsements decreasing premium and cancellations effective on the date this subchapter becomes effective and thereafter. The return surcharge shall be calculated on the same pro rata basis as the return premium. Upon reasonable notice and the provision of adequate documentation from the insurer, the Association shall refund to the policyholder any return of surcharge due that policyholder.

#### 11:18-1.5 Collection and remittance of surcharge

(a) The applicable surcharge billed to the policyholder shall be collected by each insurer at the time of payment of premium.

(b) The insurer shall remit each collected surcharge to the Treasurer for the account of the Fund not later than 10 days from the collection of the surcharge.

(c) Not later than April 1 and October 1 of each year, the Treasurer shall remit the total amount of monies received by the Fund, plus all accrued interest thereon, to the Association pursuant to N.J.S.A. 17:30D-11.

(d) Not later than March 1 and September 1 of each year, each insurer shall file with the Department of Insurance the following:

1. A listing of each Fund surcharge collected during the preceding reporting period and to which class of health care provider the surcharge applies;

2. A listing of each Fund surcharge remitted to the Treasurer during the preceding reporting period and to which class of health care provider the surcharge applies;

3. The total amount of Fund surcharges collected during the preceding reporting period;

4. The total amount of Fund surcharges remitted to the Treasurer during the preceding reporting period; and

5. A statement from an officer of the company certifying that the information submitted is accurate and complete to the best of his or her knowledge.

(e) The information required in (d) above shall be submitted to:  
Statistical Service  
Property Liability Division  
New Jersey Department of Insurance  
CN 325  
Trenton, New Jersey 08625  
Attention: MMRRF Surcharge

(f) Failure by an insurer to submit the information required in (d) above in a timely manner may result in the imposition of penalties and/or sanctions pursuant to N.J.S.A. 17:33-2 and/or other provisions of law.

(g) The applicable surcharge shall be billed to the policyholder, collected by the insurer, and remitted to the Treasurer until such time as the Commissioner determines that the monies in the fund are sufficient to meet the requirements of N.J.S.A. 17:30D-1 et seq.

(h) The insurer's obligation to collect the applicable surcharge and remit it to the Treasurer in a timely manner shall be a condition of maintaining its certificate of authority.

#### 11:18-1.6 Adjustment of surcharge

The amount of surcharge imposed by this subchapter may be adjusted by the Commissioner upon his or her consideration of revenues received and Fund expenses. Adjustments shall be made for all classes subject to the surcharge on a proportional basis. Adjustments, if any, shall be made in accordance with the rulemaking procedures of the Administrative Procedure Act, N.J.S.A. 52:14B-1 et seq.

## LABOR

### (a)

#### DIVISION OF EMPLOYMENT SECURITY

##### 1990 Maximum Weekly Benefit Rates

##### 1990 Taxable Wage Base Under the Unemployment Compensation Law

##### 1990 Contribution Rate of Governmental Entities and Instrumentalities

##### 1990 Base Week

##### 1990 Alternative Earnings Test

##### Proposed Amendments: N.J.A.C. 12:15-1.3, 1.4, 1.5, 1.6, and 1.7

Authorized By: Charles Serraino, Commissioner, Department of Labor.

Authority: N.J.S.A. 34:1-5, 34:1-20, 34:1A-3(e), 43:21-3(c), 43:21-4(e), 43:21-7(b)(3), 43:21-7.3(e), 43:21-19(t), 43:21-27, 43:21-40 and 43:21-41.

Proposal Number: PRN 1989-459.

Submit comments by October 5, 1989 to:

Alfred B. Vuocolo, Jr.

Chief Legal Officer

Office of the Commissioner

Department of Labor

CN 110

Trenton, New Jersey 08625-0110

The agency proposal follows:

#### Summary

The proposed amendment to N.J.A.C. 12:15-1.3 establishes the 1990 maximum weekly benefit rate for benefits under the Unemployment Compensation Law and for State Plan benefits under the Temporary Disability Benefits Law.

The proposed amendment to N.J.A.C. 12:15-1.4 establishes the 1990 taxable wage base for the purpose of contributions under the Unemployment Compensation Law in accordance with N.J.S.A. 43:21-7(b)(3).

The proposed amendment to N.J.A.C. 12:15-1.5 establishes the 1990 contribution rate for governmental entities that elect to pay contributions under the Unemployment Compensation Law.

The proposed amendment to N.J.A.C. 12:15-1.6 raises the amount of earnings required in 1990 to establish a base week for an individual's claim for unemployment compensation and State Plan temporary disability benefits.

Finally, the proposed amendment to N.J.A.C. 12:15-1.7 raises the amount of base year earnings required to establish an individual's eligibility for unemployment compensation and State Plan temporary disability benefits, in those instances in which the individual has not established 20 base weeks.

#### Social Impact

The proposed amendment to N.J.A.C. 12:15-1.3 will ensure that payments to unemployment and disability insurance recipients entitled to maximum benefits will increase in line with the upward trend of wages in the State's economy, thus preserving the real purchasing power of their benefits.

The proposed amendment to N.J.A.C. 12:15-1.4 will generate increased revenues for the Unemployment Insurance and Disability Insurance Trust Funds needed to offset the increased level of benefits for these programs, which are statutorily indexed to the upward trend of wages in the State's economy.

The proposed amendment to N.J.A.C. 12:15-1.5 will lower the contribution rate for governmental entities, and will have no social impact on the public.

The proposed amendments to N.J.A.C. 12:15-1.6 and 12:15-1.7 provide for the base week amount and the amount of earnings to establish eligibility, respectively, to be indexed to wage increases as benefit payments have been indexed since 1969. Some claimants who work temporarily or intermittently may not qualify for benefits under these tightened eligibility standards.

#### Economic Impact

The proposed amendment to N.J.A.C. 12:15-1.3 will increase the weekly benefit rates received by individuals eligible for the maximum weekly benefit rate under the Unemployment Compensation Law and under the Temporary Disability Benefits Law beginning January 1, 1990, in compliance with statutory provisions which automatically adjust these benefit rates each year in accordance with changes in the Statewide average weekly wage. The maximum weekly benefit for Unemployment Compensation is computed as 56 and 2/3 percent of the Statewide average weekly wage in the second preceding calendar year. As of January 1, 1990, the maximum weekly benefit will increase from \$258.00 to \$279.00.

The maximum weekly benefit for State Plan Temporary Disability is computed as 53 percent of the Statewide average weekly wage in the second preceding calendar year. As of January 1, 1990, the maximum weekly benefit will increase from \$241.00 to \$261.00.

The proposed amendment to N.J.A.C. 12:15-1.4 will increase from \$12,800 to \$13,900 the wages of an individual employee of an employer that are subject to employer and worker contributions under the Unemployment Compensation Law, beginning January 1, 1990. The taxable wage base is computed as 28 times the Statewide average weekly wage in the second preceding calendar year.

The proposed amendment to N.J.A.C. 12:15-1.5, which will lower the contribution rate for governmental entities to 0.8 percent of taxable wages for 1990 from 1.1 percent for 1989, will, other things being equal, result in lower costs to State and local government units that choose this financing option.

The proposed amendment to N.J.A.C. 12:15-1.6 will increase the amount an individual must earn to establish a base week under the Unemployment Compensation and Temporary Disability Laws. The amount is computed as 20 percent of the Statewide average weekly wage in the second preceding calendar year and will increase from \$92.00 to \$99.00 for benefit years and periods of disability commencing January 1, 1990.

The proposed amendment to N.J.A.C. 12:15-1.7 increases the alternative earnings eligibility standard under the law in those situations where the individual has not established 20 base weeks in the base year period. The amount will increase from \$5,500 in 1989 to \$6,000 in 1990. The alternative earnings test is indexed each year at 12 times the Statewide average weekly wage in the second preceding calendar year.

The Department does not expect to experience any economic impact as a result of the proposed amendments.

#### Regulatory Flexibility Statement

The proposed amendments do not impose any reporting, recordkeeping or compliance requirements on businesses. The amendments affect benefit and contribution levels under the Unemployment Compensation and Temporary Disability Benefits Laws. Thus, a regulatory flexibility analysis is not required.

Full text of the proposed amendments follows (additions indicated in boldface **thus**; deletions indicated in brackets [thus]):

#### 12:15-1.3 Maximum weekly benefit rates

(a) In accordance with the provisions of the Unemployment Compensation Law, the maximum weekly benefit rate for benefits under the Unemployment Compensation Law is hereby promulgated as being [~~\$258.00~~] **\$279.00** per week.

(b) The maximum weekly benefit rate for State Plan benefits under the Temporary Disability Benefits Law is hereby promulgated as being [~~\$241.00~~] **\$261.00** per week.

(c) These maximum benefits shall be effective for the calendar year [1989] **1990** on benefit years and periods of disability commencing on or after January 1, [1989] **1990**.

#### 12:15-1.4 Taxable wage base under the Unemployment Compensation Law

In accordance with the provisions of N.J.S.A. 43:21-7(b)(3), the "wages" of any individual with respect to any one employer for the purpose of contributions under the Unemployment Compensation Law shall include the first [~~\$12,800~~] **\$13,900** during the calendar year [1989] **1990**.

#### 12:15-1.5 Contribution rate of governmental entities and instrumentalities

(a) In accordance with the provisions of N.J.S.A. 43:21-7.3(e), the contribution rate for all governmental entities and instrumentalities electing to pay contributions under the Unemployment Compensation Law is hereby promulgated as being [one and one-tenth percent (1.1 percent)] **eight-tenths of one percent (0.8 percent)** for the entire calendar year.

(b) This contribution rate shall be effective on taxable wages paid in the calendar year [1989] **1990**.

#### 12:15-1.6 Base week

In accordance with the provisions of N.J.S.A. 43:21-19(t), the base week amount is hereby promulgated as being [~~\$92.00~~] **\$99.00** per week for benefit years and periods of disability commencing on or after January 1, [1989] **1990**.

#### 12:15-1.7 Alternative earnings test

In accordance with the provisions of N.J.S.A. 43:21-4(e) and 43:21-41 in those instances in which the individual has not established 20 base weeks, the alternative earnings amount for establishing eligibility is hereby promulgated as being [~~\$5,500~~] **\$6,000** for benefit years and periods of disability commencing on or after January 1, [1989] **1990**.

(a)

## DIVISION OF WORKERS' COMPENSATION

### 1990 Maximum Workers' Compensation Benefit Rates

#### Proposed Amendment: N.J.A.C. 12:235-1.6

Authorized By: Charles Serrano, Commissioner, Department of Labor.

Authority: N.J.S.A. 34:1-5, 34:1-20, 34:1A-3(e) and 34:15-12(a).

Proposal Number: PRN 1989-460.

Submit comments by October 5, 1989 to:

Alfred B. Vuocolo, Jr.  
Chief Legal Officer  
Office of the Commissioner  
Department of Labor  
CN 110

Trenton, New Jersey 08625-0110

The agency proposal follows:

#### Summary

The proposed amendment establishes the 1990 maximum workers' compensation rates for temporary disability, permanent total disability, permanent partial disability, and dependency.

#### Social Impact

The proposed amendment will ensure that payments to workers' compensation recipients entitled to maximum benefits will increase in line with the upward trend of wages in the State's economy, thus preserving the real purchasing power of their benefits.

#### Economic Impact

The proposed amendment will increase from \$342.00 to \$370.00 the weekly benefit rate received by individuals eligible for the maximum weekly benefit rate for temporary disability, permanent total disability, permanent partial disability, and dependency under the Workers' Compensation Law.

The effect of this change, other things being equal, will be to raise the employers' workers' compensation insurance costs.

The Department does not expect to experience any economic impact as a result of the proposed amendment.

**Regulatory Flexibility Statement**

The proposed amendment does not impose any reporting, recordkeeping or compliance requirements on businesses. The amendment increases benefit rates to individuals. Thus, a regulatory flexibility analysis is not required.

**Full text** of the proposal follows (additions indicated in boldface **thus**; deletions indicated in brackets [thus]):

12:235-1.6 Maximum workers' compensation benefit rates

(a) In accordance with the provisions of N.J.S.A. 34:15-12(a), the maximum workers' compensation benefit rate for temporary disability, permanent total disability, permanent partial disability, and dependency is hereby promulgated as being [\$342.00] **\$370.00** per week.

(b) This maximum compensation shall be effective as to injuries occurring in the calendar year [1989] **1990**.

**LAW AND PUBLIC SAFETY****(a)****DIVISION OF CONSUMER AFFAIRS****Audiology and Speech-Language Pathology  
Advisory Committee****Examination Requirements; Authorized Practice  
Exemptions****Proposed Amendments: N.J.A.C. 13:44C-3.2 and 7.2**

Authorized By: James J. Barry, Jr., Director, Division of  
Consumer Affairs.

Authority: N.J.S.A. 45:3B-24.

Proposal Number: PRN 1989-453.

Submit comments by October 5, 1989 to:

Richard Weisman, Executive Director  
Advisory Committee for Audiology and Speech-  
Language Pathology, Room 500  
100 Raymond Boulevard  
Newark, New Jersey 07102

The agency proposal follows:

**Summary**

The Audiology and Speech-Language Pathology Advisory Committee proposes two changes in its current rules covering the licensure and practice of these professions.

The first change proposed is an amendment to N.J.A.C. 13:44C-3.2(a)4, which relates to examination requirements. Here, wording that refers to percentile score would be deleted, leaving a score of 600 on the National Teachers' Examination in audiology or speech-language pathology as the sole measure of successful passage of this test, which is administered by the Educational Testing Service of Princeton, New Jersey. The Advisory Committee has reached the determination that a percentile score is insufficient to demonstrate a candidate's ability level. Such a score measures that level in comparison with the ability level of people tested in a national administration, but it does not provide clear assurance as to how well the candidate knows the subject matter being tested. Under the proposed amendment, only an explicitly determined numerical score will satisfy the Advisory Committee's requirements.

The second rule proposed to be amended is N.J.A.C. 13:44C-7.2(a)4, concerning exemptions from authorized practice requirements for certain providers of audiology or speech-language pathology services. The amendment, which adds the words "speech-language specialist," would merely coordinate the terminology of this rule on exemptions with an endorsement conferred by the Department of Education in certifying personnel for provision of services within public schools.

**Social Impact**

The proposed amendment to N.J.A.C. 13:44C-3.2(a)4 clearly benefits the public in that it raises examination standards which must be met by Advisory Committee licensees; a fixed numerical score must now be attained on the qualifying examination and the alternative percentile score will not be acceptable. Protection of the public against practice by less than fully competent persons should thereby be enhanced.

The amendment to N.J.A.C. 13:44C-7.2(a)4 will have no impact upon the public but will eliminate any confusion caused by the fact that an endorsement category of the Department of Education is not specifically named, at present, in the Advisory Committee's enumeration of exemptions from authorized practice rules. Addition of the words "speech-language specialist" to the list provides coordination and clarification that were lacking heretofore.

**Economic Impact**

Economic impact resulting from proposed amendments will be felt by candidates for licensure who do not achieve the passing score of 600 on the required National Teachers' Examination. Those persons will have to bear the cost of possible further study and of fees for any successive examinations.

**Regulatory Flexibility Statement**

Since the proposed amendments concern only holders of endorsements as speech-language specialists who teach in public schools, and candidates for licensure by the Advisory Committee, small businesses are not affected. A regulatory flexibility analysis is, therefore, not required.

**Full text** of the proposed amendments follows (additions indicated in boldface **thus**; deletions indicated by brackets [thus]):

13:44C-3.2 Requirements for licensure

(a) An applicant for licensure shall submit the following to the Advisory Committee:

1.-3. (No change.)

4. Satisfactory proof of having achieved a score of 600 [a lower score within or the 16th or greater percentile] on the National Teachers' Examinations in audiology or speech-language pathology, as appropriate, administered and set by Educational Testing Service in Princeton, New Jersey. An applicant may substitute a current and valid license to practice audiology or speech-language pathology, as is appropriate; issued by another state with substantially equivalent requirements for licensure, as satisfactory proof of having passed the examination.

13:44C-7.2 Exemptions

(a) The following are exempt from the provision of this chapter, pursuant to N.J.S.A. 45:3B-17:

1.-3. (No change.)

4. Any person certified as a speech-language correctionist **or its successor title, speech-language specialist**, by the State Department of Education. However, such person is not exempt under this section for that portion of his or her time spent as a private practitioner or providing services for which a fee may be paid by a recipient of the service.

5.-7. (No change.)

**PUBLIC UTILITIES****(b)****BOARD OF PUBLIC UTILITIES****Filing of Annual Reports and Customer Lists (Solid  
Waste)****Reproposed Amendment: N.J.A.C. 14:3-10.15**

Authorized By: Board of Public Utilities, Christine Todd  
Whitman, President.

Authority: N.J.S.A. 48:2-13, 48:13A-4 and 48:13A-11.

BPU Docket Number: SX8810 1101.

Proposal Number: PRN 1989-456.

A **public hearing** concerning this proposed amendment will be held on:  
Tuesday, October 3, 1989 at 10:00 A.M.  
Board's Hearing Room  
Two Gateway Center—10th Floor  
Newark, New Jersey

Submit written comments by October 5, 1989 to:

Eugene J. Byrne, Esq.  
Administrative Practice Officer  
Board of Public Utilities  
Two Gateway Center  
Newark, New Jersey 07102

The agency proposal follows:

#### Summary

The proposed amendment was initially published in the November 7, 1988 edition of the New Jersey Register at 20 N.J.R. 2629(a) and a public hearing thereon was held on December 8, 1988. As a result of comments received, Board staff re-examined the then proposed amendment and has made substantive changes thereto. In view of such changes, nearly all of which are by way of additions to the original proposal, the Board hereby withdraws same and repropose it as modified. The repropose amendment differs from the amendment published in the November 7, 1988 edition of the New Jersey Register as set forth below:

1. Paragraph (b)1 was expanded to require that the list of residential customers be subdivided by municipality and that within each municipality the customers shall be sequentially numbered and set forth in numerical order by street address, and the streets set forth in alphabetical order.

2. The repropose amendment also differentiates between residential customer lists and commercial, industrial and institutional lists in that only the latter are to include rate schedule(s) applied, frequency and type of service supplied and number of containers and size of each.

3. A model residential customer list format and a model commercial, industrial and institutional customer list format have been added to provide a visual example of the requirements of paragraphs (b)1 and 2.

4. Paragraph (b)5 is entirely new.

The repropose amendment is again in two parts. The first would denominate the existing rule as subsection (a) and would clarify it by stating the date annual reports by solid waste utilities are due to be filed. The second and more important amendment, denominated subsection (b), would require the annual filing of customer lists by solid waste collectors.

Proposed N.J.A.C. 14:3-10.15(b) would require each solid waste utility engaged in the business of collecting solid waste in the State of New Jersey to, no later than March 31, of each year, file with the Secretary of the Board of Public Utilities detailed information regarding its customers. Such information shall be made under oath and shall include a complete and sequentially numbered list of all residential, commercial, industrial and institutional customers. The list of residential customers shall be subdivided by municipality. Within each municipality the customers shall be sequentially numbered and set forth in numerical order by street address and the streets set forth in alphabetical order. The list shall include the name and address (including street, post office box, city, zip code and any other identifying data) of each customer as of December 31 of the preceding year. The list of commercial, industrial or institutional customers shall also include the following: rate schedule(s) applied, frequency and type of service and number of containers and size of each. The collector shall also be required to provide an explanation for any changes in the total number and/or names of commercial, industrial or institutional customers from those supplied in the preceding year.

The Board will respect the confidential nature of these lists by providing adequate safeguards against public disclosure. Such safeguards will include placing the lists in a locked filing cabinet and limiting access to agents and employees of the Board of Public Utilities and in the discretion of the Board those Governmental agencies responsible for enforcement of laws relating to the collection and disposal of solid waste.

#### Scope of Board's Jurisdiction

There are numerous provisions under Title 48 which form the basis for the Board's authority to compel the production of customer lists.

The Board's general powers over public utilities including those engaged in solid waste collection and disposal are found in N.J.S.A. 48:2-13 which provides as follows:

"The Board shall have general supervision and regulation of and jurisdiction and control over all public utilities as hereinafter in this section defined and their property, property rights, equipment, facilities and franchises so far as may be necessary for the purposes of carrying out the provisions of this Title."

Additionally, pursuant to N.J.S.A. 48:13A-2 the Board is charged with the duty of setting and enforcing standards and rates for regulating the economic aspects of solid waste collection and disposal.

N.J.S.A. 48:13A-6 empowers the Board to issue certificates of public convenience and necessity.

N.J.S.A. 48:13A-7 enables the Board to direct those engaged in the business of solid waste collection and disposal to furnish proof that the charges or rates received for service do not exceed just and reasonable rates or charges for such service.

N.J.S.A. 48:13A-10 prohibits monopolistic practices in the solid waste collection and disposal business.

N.J.S.A. 48:13A-11 empowers the Board to "... compel the attendance of witnesses and the production of tariffs, contracts, papers, books, accounts and all other documents necessary to enable the Board to administer its duties as prescribed by law..."

In *In re Solid Waste Utility Customer Lists*, 106 N.J. 508 (1987), the Supreme Court held that the Board of Public Utilities has authority to compel production of customer lists so long as adequate safeguards against public disclosure are provided.

#### Social Impact

The repropose amendment requiring the production of customer lists will assist the Board in implementing its statutory mandate set forth in N.J.S.A. 48:13A-2.

N.J.S.A. 48:13A-2 provides in pertinent part as follows:

"... the health, safety and welfare of the people of this state require efficient and reasonable solid waste collection disposal and utilization service; that such service will more likely be achieved if the Public Utility Commission is charged with the duty of setting and enforcing standards and rates for regulating economic aspects of solid waste collection, disposal and utilization service..."

The production of customer lists enables the Board and its staff to investigate any possible consumer fraud by providing the Board with the identities of customers and the rates charged for services rendered to said customers.

#### Economic Impact

The repropose amendment is essential in order for the Board to effectively regulate the economic practices of the solid waste industry.

The utilization of these lists will facilitate the protection of the economic interests of the public by placing the Board in a better position to identify, and take appropriate action to prevent, actual and potential anticompetitive practices and abuses of the rate structure.

The repropose amendment will not impose an undue economic burden upon solid waste collection utilities as the mere duplication and dissemination of existing records involves a minimal capital outlay and is clearly outweighed by the public interest.

#### Regulatory Flexibility Analysis

The majority of solid waste collectors which this amendment will affect are small businesses. There are approximately 758 solid waste collectors, approximately four of which have more than 100 employees. Since the utility would use its existing records to provide the required data, there would be minimal initial capital cost and minimal annual cost of compliance. The estimated annual cost to a utility with a computerized billing system in place would be \$20.00. The annual cost to a utility without such a system is approximately \$100.00. It is not anticipated that the utility would need to employ professional services to comply with this amendment.

**Full text of the proposal follows (additions indicated in boldface thus):**

#### 14:3-10.15 Filing of annual reports and customer lists

(a) Every utility engaged in solid waste collection and solid waste disposal shall file **no later than March 31 of each year** an annual report on forms to be prescribed by the Board for filing, showing its financial condition on a calendar year basis. Such reports shall also contain a statement of income and expenses for a calendar year period.

(b) Every utility engaged in solid waste collection shall file **no later than March 31 of each year, with the Secretary of the Board, a complete list, made under oath, of all residential, commercial, industrial and institutional customers.**

1. **The list of residential customers shall be subdivided by municipality. Within each municipality, the customers shall be sequentially numbered and set forth in numerical order by street address and the streets set forth in alphabetical order. The list shall include each cus-**

tomers' complete name and address (including post office box, zip code and any other identifying data) as of December 31 of the preceding year.

2. The list of commercial, industrial or institutional customers shall be set forth as in (b)1 above and, in addition, shall include for each customer the rate schedule(s) applied, frequency and type of service supplied, and number of containers and the size of each.

3. If a change occurs in the total number and/or names of commercial, industrial or institutional customers supplied in the preceding year, the collector shall provide an explanation for the change and the date and docket number of the Board's order, if any, authorizing such change.

4. Pursuant to N.J.S.A. 47:1A-2 of the Right to Know Law, N.J.S.A. 47:1A-1 et seq., the customer lists filed with the Secretary pursuant to this section shall not be deemed to be public records and the public, including solid waste or other utilities, shall not have the right to inspect, copy or obtain a copy of same. Upon receipt of the customer lists, the Secretary of the Board shall keep the lists under lock and take appropriate measures to maintain the lists in confidence. Access to such lists shall be limited to agents, employees and attorneys of the Board and, in the discretion of the Board, governmental agencies responsible for enforcement of laws relating to the collection and disposal of solid waste. All such governmental agencies shall be subject to the confidentiality requirements contained in this paragraph.

5. If a collector's Certificate of Public Convenience and Necessity is revoked, or for other good cause as the public interest may demand, the Board in its discretion may disclose the customer list of such collector for purposes of insuring safe, adequate and proper service.

6. Customer list formats are as follows:

i. MODEL RESIDENTIAL CUSTOMER LIST FORMAT

| CUSTOMER # | NAME | ADDRESS                               |
|------------|------|---------------------------------------|
| 1.         | ABC  | One A Street, Allentown, NJ 10000     |
| 2.         | DCE  | One B Street, Allentown, NJ 10000     |
| 1.         | FGH  | One A Street, Basking Ridge, NJ 20000 |
| 2.         | IJK  | One B Street, Basking Ridge, NJ 20000 |

ii. MODEL COMMERCIAL, INDUSTRIAL AND INSTITUTIONAL CUSTOMER LIST FORMAT

| CUSTOMER # | NAME                         | ADDRESS                                |
|------------|------------------------------|--|
| 1.         | ABC                          | One A Street, Allentown, NJ 10000      |
|            | RATE SCHEDULE(S) APPLIED     | FREQUENCY AND TYPE OF SERVICE/PER PULL |
|            | No. 10 Waste                 | 2 x Week/Roll Off                      |
|            | NUMBER AND SIZE OF CONTAINER |  |
|            | 2-8 Cubic Yard               |  |

(a)

**BOARD OF PUBLIC UTILITIES  
Notice of Extension of Comment Period  
Overearnings  
Proposed New Rules: N.J.A.C. 14:3-11**

Take notice that the Board of Public Utilities is extending until October 2, 1989, the period for the submission of written comments on the proposed adoption of new rules concerning overearnings.

The proposal was published on July 17, 1989, in the New Jersey Register at 21 N.J.R. 2003(a). Please refer to the proposal for additional information.

Interested persons may submit written comments on the proposal until October 2, 1989 to:

Eugene J. Byrne, Esq.  
Administrative Practice Officer  
Board of Public Utilities  
Two Gateway Center  
Newark, New Jersey 07102

(b)

**BOARD OF PUBLIC UTILITIES  
Solid Waste Uniform Tariff  
Proposed New Rules: N.J.A.C. 14:11-7.6 through 7.9  
Proposed Amendment: N.J.A.C. 14:11-7.2**

Authorized By: Board of Public Utilities, Christine Todd Whitman, President.

Authority: N.J.S.A. 48:2-13, 48:13A-4, and 48:2-21.

BPU Docket Number: SX89070669.

Proposal Number: PRN 1989-457.

Public hearings concerning this proposal will be held on:

September 28, 1989 at 10:00 A.M.

Board's Hearing Room

Two Gateway Center, 10th Floor

Newark, New Jersey 07102

October 2, 1989 at 10:00 A.M.

Hall of Records, Room 210

Main Street

Freehold, N.J. 07728

October 6, 1989 at 10:00 A.M.

Galloway Municipal Complex

300 East Jimmey Leeds Rd.

Galloway, N.J. 08208

Submit written comments by October 6, 1989 to:

Wayne DeFeo

Deputy Director

Division of Solid Waste

Board of Public Utilities

Two Gateway Center

Newark, New Jersey 07102

The agency proposal follows:

**Summary**

Effective January 1, 1990, all solid waste collection utilities will file one form of tariff with the Board of Public Utilities, Division of Solid Waste Uniform Tariff. The proposed amendment and new rules set forth the requirements for this tariff.

N.J.A.C. 14:11-7.6, Definitions, establishes uniform definitions of waste type and basic services. N.J.A.C. 14:11-7.7, Tariff terms and conditions, establishes uniform terms of service and billing procedures. N.J.A.C. 14:11-7.8, Directions for filing Solid Waste Tariffs, outlines directions, establishes formulas and conversion factors and compaction ratios for use in this section to establish a two component rate structure. N.J.A.C. 14:11-7.9, Solid Waste Uniform Tariff Forms, establishes a systematized format to be filed for each type of service rendered.

This proposed amendment and new rules will result in a less cumbersome regulatory process and will allow the ratepayers to more effectively analyze their bills. In addition, the tariff review process will be shortened under the proposed provisions of N.J.A.C. 14:11-7.6 and 7.7, while N.J.A.C. 14:11-7.8 and 7.9 will provide a consistent format for collection utilities to utilize when filing tariff amendments.

**Social Impact**

Implementation of the uniform tariff will benefit every sector of the public. By providing uniform definitions, terms of service and billing procedures, all solid waste collectors will compete from a position of equity, fostering a greater potential for service competition. In addition, the systematized rate schedules and standard terms and conditions will provide ratepayers with greater ability to compare prices and services and will minimize instances of unsatisfied expectations. Further, the Board will be able to provide more effective regulatory oversight with a reduction in lengthy reviews of unorganized tariffs, provide for more effective service enforcement and respond to customer inquiries in a more effective manner.

The disposal component will be adjusted by Board Order in the context of its decisions on disposal facility rates. This will eliminate the need for collectors to file formal rate cases each time a disposal rate changes. Revised tariff pages may be all that is required.

**Economic Impact**

The uniform tariff will have a positive economic impact on the Board of Public Utilities (Board), the Department of Environmental Protection

(DEP), solid waste collection utilities and the customers of those solid waste collection utilities. The standardization and simplification of tariff filings will enable regulatory agencies responsible for regulation of the solid waste industry to conduct analysis of individual tariff filings expeditiously, thereby maximizing the efficiency and effectiveness of the administrative process. Implementation of a uniform tariff will assist both the Board and the DEP in their respective enforcement functions. The standard terms and conditions contained in the uniform tariff will enable customers of solid waste collection utilities to make informed decisions when selecting a collector by comparing respective rates for specific types of service thereby fostering competition in the solid waste industry. The utilization of the uniform tariff by solid waste collection utilities will ultimately make the tariff filing process more cost-efficient by standardizing and simplifying solid waste collection utility tariffs, thereby reducing the costs (legal and accounting fees) associated with subsequent tariff filings.

#### Regulatory Flexibility Analysis

The majority of solid waste collectors which these rules will affect are small businesses. There are approximately 758 solid waste collectors, approximately four of which have more than 100 employees. The utilization of a uniform tariff may initially increase the costs associated with the filing of solid waste collection utility tariffs by approximately \$3,000 in view of the possibility that collectors may need to employ professional services to comply with these rules. With standardization, however, the costs associated with the filing of subsequent tariffs will be substantially lessened. Given the great predominance of small businesses in the solid waste collection industry, no basis for differentiation of compliance requirements based on business size exists.

Full text of the proposal follows (additions indicated in boldface thus):

#### 14:11-7.2 General

(a)-(b) (No change.)

**(c) Effective January 1, 1990, all solid waste collection tariffs shall conform with the format and language as outlined in 14:11-7.3, 7.4 and 7.6 through 7.9.**

#### 14:11-7.6 Solid Waste Uniform Tariff; definitions

For purposes of this subchapter, the following words and terms have the following meanings:

"Bulky waste" means waste type 13, N.J.A.C. 7:26-2.13, and includes large items of waste material, such as, appliances, furniture, tires, whole trees, branches, tree trunks and stumps generated by residential, commercial, institutional or industrial sources. Also included are waste building materials and rubble resulting from construction, remodeling, repair and demolition operations on houses, commercial buildings, improvements and other structures. Specifically excluded for the purpose of Board regulation are discarded automobiles, trucks and trailers and large vehicle parts.

"Commercial solid waste" means waste type 10, N.J.A.C. 7:26-2.13, which is normally generated in wholesale, retail or service establishments, including, but not limited to, restaurants, stores, markets, theaters, hotels and warehouses.

"Compacted waste" means waste that has been compressed by non-residential mechanical or hydraulic machinery.

"Dry sewage sludge" means waste type 12, N.J.A.C. 7:26-2.13, and is sludge from a sewage treatment plant which has been digested and dewatered and does not require liquid handling equipment.

"Hazardous waste" means any waste type in N.J.A.C. 7:26-8.1.

"Industrial solid waste" means waste type 27, N.J.A.C. 7:26-2.13, which is normally generated in manufacturing, industrial, and research and development processes and operations which are non-hazardous in accordance with the standards and procedures set forth in N.J.A.C. 7:26-8.1.

"Institutional solid waste" means waste type 10, N.J.A.C. 7:26-2.13, which is normally generated in the operation of institutions, including, but not limited to, hospitals, colleges, schools, nursing homes, medical and dental professional buildings, research and development processes, and laboratories.

"Leaf compost facilities" means those permitted facilities where predominately leaves are composted into a humus product for reuse.

"Limited service" means service that is available only at certain specified hours of the day or season of the year.

"Liquid wastes" means waste types 72, 73, and 74, N.J.A.C. 7:26-2.13, including bulk liquids and semi-liquids, septic tank cleanout wastes and liquid sewage sludge. They include liquids or a mixture consisting of solid matter suspended in a liquid media which is contained within, or is discharged from, any one vessel, tank, other container which has the capacity of 20 gallons or more (not included is waste type 12); pumping from septic tanks and cesspools; and liquid residue from a sewage treatment plant consisting of sewage solids combined with water and dissolved materials.

"Loose waste" means waste that is un-compacted.

"Mixed district loads" means waste of the same type but from different solid waste management districts contained in the same container.

"Mixed waste types" means two or more waste types in the same container.

"Multiple dwelling" means any building of one or more stories which contains three or more dwelling units. The solid waste generated by residents of a multiple dwelling may be considered ID 10 commercial for economic regulation purposes.

"Recycling" means any process by which materials which would otherwise become solid waste are collected, separated, or processed and returned to the economic mainstream in the form of raw materials or products. Materials to be recycled include those materials as defined in P.L. 1987, c.102 (N.J.S.A. 13:1E-99) and county solid waste management plans.

"Residential refuse collection, basic service, curb collection" means service by the collector which requires collection by the collector at the curb of the residence.

"Residential refuse collection, basic service, drive-in" means service by the collector which requires collection by the collector at a point other than the curb of the residence, and requires the collector to drive the collection vehicle beyond the curb in order to make the collection.

"Residential refuse collection, basic service, walk-in" means service by the collector at a point other than the curb of the residence involved, provided such other collection point does not require the collector to drive the collection vehicle beyond the curb to the point of collection, or walk a distance greater than 50 feet from curblane.

"Residential refuse collection, special collection" means service that requires the collection of residential solid waste at irregular intervals.

"Residential solid waste" means waste type 10, N.J.A.C. 7:26-2.13, which is normally generated in the day to day activities of a residence and includes animal and vegetable waste resulting from the handling, processing, preparing, cooking and consuming of food, and includes household liquids except used motor oil and grass clippings.

"Resource recovery facility" means a solid waste facility constructed and operated for the incineration of solid waste for energy production and the recovery of the metals and other materials for refuse, or a mechanized compost facility or any other solid waste facility constructed or operated for the collection, separation, recycling of metals, glass, paper and other materials for reuse or for energy production. N.J.S.A. 13:1E-137.

"Sanitary landfill" means a permitted solid waste facility, at which solid waste is deposited on or into the land as fill for the purpose of permanent disposal or storage for a period of time exceeding six months, except that it shall not include any waste facility approved for disposal of hazardous waste. N.J.S.A. 13:1E-3.

"Transfer station" means a facility at which solid waste is transferred from one solid waste collection vehicle to a licensed solid waste vehicle for transportation to a solid waste facility. N.J.A.C. 7:26-1.4.

"Vegetative waste" means waste type 23, N.J.A.C. 7:26-2.13, and includes waste materials from farms, plant nurseries and greenhouses that are produced from the raising of plants. This waste includes such crop residues as plant stalks, hulls, leaves and tree wastes processed through a wood chipper.

#### 14:11-7.7 Tariff terms and conditions

(a) The following terms and conditions shall apply to all solid waste collection companies.

1. The solid waste collection utility shall have unencumbered access to any customer's container, utility container or other area from which solid waste is to be collected. If containers are located in an enclosed structure, said structure must allow for access. In the event that the structure prevents access, the collector shall not be required to remain on the premises to attempt collection. The collector may leave, and shall return on the next regularly scheduled collection date. All containers and areas from which solid waste is to be collected must be kept free from all hazards and potential hazards. During periods of inclement weather, containers are to be reasonably free from ice and snow.

2. Collection services shall be provided according to a schedule contained in an accepted tariff.

3. The collector may provide collection for yard clippings, garden refuse and other types of solid waste not provided for in the basic service. Specific provisions must be outlined in the appropriate service section of the collector's tariff.

4. The collector may require that solid waste potentially dangerous to health and liable to cause injury be packaged in a manner which limits the possibility of exposure and/or injury.

5. Collectors are prohibited from offering to collect commingled loads of solid waste and designated source separated recyclable materials. Each solid waste management plan contains a definition of the district's designated recyclables.

i. Collectors are prohibited from disposing of leaves as outlined in N.J.S.A. 13:1E-99.21.

6. Should the collector fail to pick up solid waste on a regularly scheduled day, and such failure is not due to any action or inaction of the customer, the collector shall make the pick up as soon as possible.

7. In the event of inclement weather when operation of a solid waste collection vehicle would pose a threat to the safety and welfare of the public and/or the equipment and personnel of the collector, collections will be made no later than the next regularly scheduled pick-up. In those cases where collection is scheduled on a one collection per week basis, that collection will be made as soon as possible.

8. Service to a customer may be discontinued in accordance with the provisions of N.J.A.C. 14:3-7.12, Billing, payments, deposits.

9. Residential customers who wish to discontinue or suspend service for periods of 30 days or more must give notice to the utility not less than 30 days prior to the date they wish temporary discontinuance of service and indicate the date they wish service to resume. Failure to notify the utility will result in no reduction of monthly rate billed.

10. The solid waste collection utility shall have the right to terminate a customer's service upon seven days written notice for any of the following acts or omissions on the part of the customer:

i. Non-payment of a valid bill at a present or previous location. Non-payment of bill for service to a commercial establishment shall not be cause for discontinuance of residential service;

ii. Tampering with any facility of the utility;

iii. Fraudulent representation in relation to use of service;

iv. Customer moving from the premises unless the customer requests that the service be continued;

v. Providing a utility's service to others without approval of the utility; or

vi. Failure to make or increase an advance payment or deposit as provided for in the utility's tariff.

11. The collector shall have the right to refuse pick-up of waste for any of the following reasons:

i. Waste is not placed in proper containers;

ii. Waste is not placed at designated pick-up location;

iii. Waste contains hazardous material (as defined in N.J.A.C. 7:26-8.1), matter is likely to cause injury to the public or the collector's personnel;

iv. Waste is not placed out for collection on the scheduled day;

v. Passage on the street or into the property is obstructed in any way by the operations to pave the street, by the digging of water or sewer lines or other type of construction. Pick up will be provided for the next scheduled day;

vi. The collector is asked to move his vehicle by an authorized government official or a member of the local police or fire depart-

ment because the customer, either residential, commercial or industrial, has not provided either adequate or legal parking for the collection of garbage, refuse or solid waste. Under these circumstances, the collector may leave and not be obligated to return until the next regularly scheduled date;

vii. Containers exceed prescribed weight or volume limits as prescribed in the collector's tariff;

viii. Containers are over filled or overflowing; or

ix. The particular service and/or waste type is not included in the collector's tariff.

(b) The following provisions shall apply to all solid waste collection companies regarding billings and payment for services:

1. The collector may bill customers for service on a monthly basis in advance. Bills for payment of services shall be mailed to the address indicated by the customer at the time service is requested, absent subsequent notice by the customer.

2. If the collector does not utilize advanced billing, residential, commercial and industrial solid waste collection billings are to be made with payment due in 30 days and payable within 10 days after the month's service has been rendered. If payment has not been received after 10 days after the date the bill was payable, then the collector may discontinue the service of the customer providing seven days written notice is given (see N.J.A.C. 14:3-7.12).

3. All bills for collection will include the following information:

i. The date of the bill;

ii. The time period for which the service is rendered;

iii. The type of and frequency of service;

iv. The tariff rate applied;

v. The number and size of containers, where applicable;

vi. The total quantity of waste collected;

vii. A separate line item showing the surcharge applied as required by the Recycling Act, N.J.S.A. 13:1E-99 et seq., and the Sanitary Landfill Facility Closure and Contingency Fund Act, N.J.S.A. 13:1E-100 et seq.;

viii. A separate line item showing the surcharge applied, if any, pursuant to P.L. 1981, c. 438, to fund county health department enforcement activities, N.J.S.A. 13:1E-9.1;

ix. Separate line items showing the Solid Waste Service Tax, Resource Recovery Investment Tax and, if applicable, Solid Waste Importation Tax, N.J.S.A. 13:1E-136 et seq.; and

x. A separate line item showing the Host Community Benefit surcharge, if any.

4. Residential rates are based on an annual service. No credit will be extended to the customer or deduction allowed should the collector fail to make a collection for reasons outside the collector's control, or should the customer not provide refuse, garbage or solid waste for collection except as allowed in N.J.A.C. 14:11-7.7(a)9.

5. If credit has not been established by the customer, the collector may, at his option, request a reasonable deposit as a condition of providing service. Initial deposits are not to exceed one month's estimated charges. All deposits retained by the utility will bear interest at the rate of nine percent per annum simple interest, N.J.A.C. 14:3-7.2 and 7.5. Periodic review of a customer's credit worthiness and the appropriate level of deposit, where necessary, will be performed according to the guidelines specified in N.J.A.C. 14:3-7.2 and 7.5. Deposits are to be returned to the customer with accumulated interest after satisfactory credit has been established.

i. Customers who have defaulted in payment of bills may be required to furnish a deposit or increase an existing deposit to secure payment of future bills. Failure to make required deposits may be considered cause for discontinuance of service after the required seven days notice is given in writing. Customers having deposits with the collector who fail to pay their bills may have their deposits used by the collector to pay existing bills and be required to bring deposits to a satisfactory level, within a reasonable time period as a condition of service, as outlined in N.J.A.C. 14:3-7.3(b).

6. No customer shall be required to pay, reward or to give any additional gratuity to receive the waste collection services to which he is entitled by contract or regulation.

7. The collector may require from institutional, commercial and industrial customers a written acknowledgment of services rendered (receipt). Such receipt will be provided by the collector and may state

the date, time of arrival, time of departure, amount of refuse removed as well as other information reasonably necessary for account billing. The collector shall provide a copy of the receipt to the customer.

8. Where more than one rate schedule is available to a particular customer, the utility shall have at all times the responsibility to assist such customers in the selection of the rate schedule most favorable for their individual requirements and to make every reasonable effort to ensure that such customers are served under the most advantageous schedule.

14:11-7.8 Directions for filing solid waste tariffs

(a) All solid waste collection utility tariffs shall conform to the outline prescribed in this subchapter. Language included in this section shall be incorporated exactly as outlined. All services and charges therefor shall be outlined using the component rate structures and formulas provided in N.J.A.C. 14:11-7.7 and this section unless otherwise noted herein. Each type of service offered must be listed on a separate page, by county and arranged alphabetically by county. All solid waste collection utilities shall, on or before December 31, 1990, revise their tariffs to conform to the requirements of this subchapter. All initial tariffs filed after December 31, 1989 shall conform to the requirements of this subchapter. The following steps in (b) through (d) shall be used to convert existing tariff rates to the format contained in this subchapter. The conversion methodology employed herein utilizes an average compaction ratio of five to one for residential solid waste, and an average conversion ratio of 3.3 cubic yards of compacted waste to one ton.

(b) Residential service (volume) monthly disposal charge shall be calculated as follows:

- 1. Size of cans/bags picked up \_\_\_\_\_ gallons.
2. Number of cans/bags per pick-up \_\_\_\_\_ .
3. Number of pick-ups per week \_\_\_\_\_ .
4. Multiply line 1 x line 2 = \_\_\_\_\_ .
5. Multiply line 4 x line 3 = \_\_\_\_\_ gallons per week.
6. Multiply line 5 x 52 weeks = \_\_\_\_\_ gallons per year.
7. Divide line 6 by 202 = \_\_\_\_\_ cubic yards.
8. Divide line 7 by 5 = \_\_\_\_\_ compacted cubic yards.
9. Divide line 8 by 3.3 = \_\_\_\_\_ tons/yr per customer.
10. Multiply line 9 by disposal cost/ton (excluding taxes and surcharges) = \_\_\_\_\_ disposal cost/year.
11. Divide line 10 by 12 = \_\_\_\_\_ monthly disposal charge.

(c) Residential service (weight) monthly disposal charge shall be calculated as follows:

- 1. Allowable weight per can/bag \_\_\_\_\_ lbs.
2. Number of cans/bags per pick-up \_\_\_\_\_ .
3. Number of pick-ups per week \_\_\_\_\_ .
4. Multiply line 2 x line 3 \_\_\_\_\_ .
5. Multiply line 4 x 52 weeks \_\_\_\_\_ .
6. Multiply line 5 x allowable weight of containers \_\_\_\_\_ lbs.
7. Divide line 6 by 2000 \_\_\_\_\_ tons.
8. Multiply line 7 by disposal cost/ton (exclusive of surcharges, taxes) \_\_\_\_\_ disposal cost/year.
9. Divide line 8 by 12 \_\_\_\_\_ monthly disposal charge.

(d) Container service monthly disposal charge shall be calculated as follows:

- 1. Container size \_\_\_\_\_ cubic yards.
2. Number of pick-ups per week (or month) \_\_\_\_\_ .
3. Multiply line 1 x line 2 \_\_\_\_\_ cubic yards.
4. Multiply line 3 x 52 for weekly pick-up or 12 for monthly pick-up \_\_\_\_\_ cubic yards/year.
5. Divide line 4 by 5 \_\_\_\_\_ compacted cubic yards per year.
6. Divide line 5 by 3.3 \_\_\_\_\_ tons per year.
7. Multiply line 6 by disposal cost per ton (exclusive of surcharges, taxes) \_\_\_\_\_ disposal charge per year.
8. Divide line 7 by 12 \_\_\_\_\_ monthly disposal charge.

(e) In converting to this tariff format, collection utilities shall be required to certify, in a form prescribed by the Board, to the following:

- 1. That rates have not changed as a result of the conversion to the uniform tariff;
2. That the disposal components contained in the tariff are based on the container weights established by the Board;
3. That no services have changed as a result of the conversion to the uniform tariff;
4. That no additional service areas or collection services have been added during conversion to the uniform tariff;
5. That the tariff rates contained in the collector's uniform tariff are and will continue to be charged to all customers of the utility; and
6. Effective with the Annual Report for the year 1990, a county by county breakdown of disposal expenses, which includes allocation of disposal expenses among residential, commercial, industrial, and contractual (municipal segregated from others) services.

14:11-7.9 Solid waste uniform tariff forms

(a) All solid waste collection utilities shall use the following forms in filing their solid waste uniform tariff:

TARIFF COVER PAGE

1. Application

This Tariff contains the regulations and schedules of rates governing services and equipment furnished by a public utility and holder of a Certificate of Public Convenience and Necessity (# \_\_\_\_\_) for the collection and/or disposal of solid waste. The Utility's principal location is:

street address \_\_\_\_\_
town/city \_\_\_\_\_ state \_\_\_\_\_
zip \_\_\_\_\_, telephone ( \_\_\_\_\_ ) \_\_\_\_\_.

2. Territory Served

Solid Waste Collection Services are provided by the collector as set forth in this document and are applicable in the Counties of:

- A
B
C
etc.

By the filing of this Tariff Document, the Utility named above agrees to conform with all rules and regulations promulgated by the County Solid Waste Management Plans, the Board of Public Utilities and the New Jersey Department of Environmental Protection in accordance with N.J.S.A. 48:1 et seq., & N.J.S.A. 13:1E et seq.

**3. Hours and Dates of Operation**

The collector shall pick up waste between the hours of \_\_\_\_\_ a.m. and \_\_\_\_\_ p.m. throughout the year \_\_\_\_\_ days per week with the exception of the following holidays: \_\_\_\_\_

When a scheduled collection day occurs on a listed holiday, collection will be made on the next scheduled day. In those cases where collection is scheduled on one collection per week basis, collection will be made within 48 hours.

**4. Change Notations**

When a tariff revision is submitted, new items are to be underlined. Items to be removed from the tariff are to be placed in brackets [ ]. All changes shall be followed by a listing of the Board's Docket Numbers and the effective change date in parenthesis ( ).

**4. TERMS OF PAYMENT:**

**RESIDENTIAL SERVICE**

**5. Application of Charges**

The rates contained herein do not include applicable taxes and surcharges. These charges are listed on the customer's bill as prescribed in the Tariff Terms and Conditions *N.J.A.C. 14:11-7.7(b)*.

|   |   |
|---|---|
| Application in _____ County                 | Waste Directed to _____ Disposal Facility |
| Service Charge                              | Disposal Charge                           |
|   | _____ Containers Per                      |
|   | Pick-up @ _____ gals                      |
|   | or lbs. or                                |
|   | Per Container Charge                      |
|   | if applicable                             |
| Additional Container Charge (if applicable) | Monthly Charge                            |

**Curbside Service (if applicable)**

|         |       |   |       |   |       |   |       |
|---------|-------|---|-------|---|-------|---|-------|
| 1 X /wk | _____ | + | _____ | + | _____ | = | _____ |
| 2 X /wk | _____ | + | _____ | + | _____ | = | _____ |
| other   | _____ | + | _____ | + | _____ | = | _____ |

**Walk in Service \* (if applicable)**

|         |       |   |       |   |       |   |       |
|---------|-------|---|-------|---|-------|---|-------|
| 1 X /wk | _____ | + | _____ | + | _____ | = | _____ |
| 2 X /wk | _____ | + | _____ | + | _____ | = | _____ |
| other   | _____ | + | _____ | + | _____ | = | _____ |

\*Additional Walk in Fee for each 50 ft. increment or part thereof beyond Standard walk in distance of 50 ft.

(Customer Note: To determine total walk-in rate add appropriate additional walk in fee to total rate from above.)

**Drive in Service (if applicable)**

|         |       |   |       |   |       |   |       |
|---------|-------|---|-------|---|-------|---|-------|
| 1 X /wk | _____ | + | _____ | + | _____ | = | _____ |
| 2 X /wk | _____ | + | _____ | + | _____ | = | _____ |
| other   | _____ | + | _____ | + | _____ | = | _____ |

(Add pages for each county serviced. Arrange alphabetically by county.)

**5. Liability Statement (if applicable)**

**RESIDENTIAL SERVICE**

|                                 |      |
|---------------------------------|------|
| Table of Contents               | Page |
| 1. DESCRIPTION .....            | 00   |
| 2. GENERAL PROVISIONS .....     | 00   |
| 3. CONTAINERS .....             | 00   |
| 4. TERMS OF PAYMENT .....       | 00   |
| 5. APPLICATION OF CHARGES ..... | 00   |
| SERVICE CHARGE .....            | 00   |
| DISPOSAL CHARGE .....           | 00   |

**RESIDENTIAL SERVICE**

**1. Description**

This section contains the general provisions and charges applicable to the provision of residential solid waste service.

**2. General Provisions:**

Service is limited to collection and disposal of residential solid waste as defined in 14:11-7.6. Supplemental services, if any, are provided for in the miscellaneous service section of these forms.

**3. Containers:**

Containers are limited to a maximum capacity of \_\_\_\_\_.

**COMMERCIAL, INDUSTRIAL AND INSTITUTIONAL  
SERVICE CONTAINER SERVICE**

3. Containers: (includes number and size of containers)

|   |      |
|---|------|
| Table of Contents                       | Page |
| 1. DESCRIPTION .....                    | 00   |
| 2. GENERAL PROVISIONS .....             | 00   |
| 3. CONTAINERS .....                     | 00   |
| 4. CONTAINER OWNERSHIP .....            | 00   |
| 5. JOINT USE/SHARING .....              | 00   |
| 6. TERMS OF PAYMENT .....               | 00   |
| 7. APPLICATION OF SERVICE CHARGES ..... | 00   |

4. Container Ownership:

5. Joint Use/Sharing

Sharing of containers is prohibited unless prior arrangements are made with the collector concerning joint use of the container. Waste quantity, container rental and service charges will be assessed based upon the percentage use of each customer.

6. Terms of Payment

7. Application of Charges

The rates contained herein do not include applicable taxes and surcharges. These charges are listed on each customers bill as prescribed in Tariff Terms and Conditions *N.J.A.C. 14:11-7.7(b)*.

**CONTAINER SERVICE**

1. Description

This section contains the general provisions and charges applicable to the provision of containerized general service.

2. General Provisions:

**WASTE TYPE—COMPACTED**

**DISPOSAL CHARGE**

|                | FREQUENCY OF SERVICE |   |   | PICK-UPS PER WEEK/MONTH |   |   | OTHER |
|----------------|----------------------|---|---|-------------------------|---|---|-------|
|                | 1                    | 2 | 3 | 4                       | 5 | 6 |       |
| CONTAINER      | 1                    | — | — | —                       | — | — | —     |
| SIZE in        | 2                    |   |   |                         |   |   |       |
| cubic          | 3                    |   |   |                         |   |   |       |
| yards          | 4                    |   |   |                         |   |   |       |
|                | 5                    |   |   |                         |   |   |       |
|                | 6                    |   |   |                         |   |   |       |
|                | 7                    |   |   |                         |   |   |       |
|                | 8                    |   |   |                         |   |   |       |
|                | 9                    |   |   |                         |   |   |       |
|                | 10                   |   |   |                         |   |   |       |
|                | 11                   |   |   |                         |   |   |       |
|                | 12                   |   |   |                         |   |   |       |
| OTHER          |                      |   |   |                         |   |   |       |
| SERVICE CHARGE | —                    | — | — | —                       | — | — | —     |

MINIMUM MONTHLY SERVICE CHARGE \_\_\_\_\_  
(if applicable)

7. Application of Charges

The rates contained herein do not include applicable taxes and surcharges. These charges are listed on each customers bill as prescribed in Tariff Terms and Conditions *N.J.A.C. 14:11-7.7(b)*.

**WASTE TYPE—UNCOMPACTED**

Front Rear (circle one)

**DISPOSAL CHARGE**

|                               | FREQUENCY OF SERVICE |   |   | PICK-UPS PER WEEK/MONTH |   |   | OTHER |
|-------------------------------|----------------------|---|---|-------------------------|---|---|-------|
|                               | 1                    | 2 | 3 | 4                       | 5 | 6 |       |
| CONTAINER SIZE in cubic yards |                      |   |   |                         |   |   |       |
| 1                             |                      |   |   |                         |   |   |       |
| 2                             |                      |   |   |                         |   |   |       |
| 3                             |                      |   |   |                         |   |   |       |
| 4                             |                      |   |   |                         |   |   |       |
| 5                             |                      |   |   |                         |   |   |       |
| 6                             |                      |   |   |                         |   |   |       |
| 7                             |                      |   |   |                         |   |   |       |
| 8                             |                      |   |   |                         |   |   |       |
| 9                             |                      |   |   |                         |   |   |       |
| 10                            |                      |   |   |                         |   |   |       |
| 11                            |                      |   |   |                         |   |   |       |
| 12                            |                      |   |   |                         |   |   |       |
| <u>OTHER</u>                  |                      |   |   |                         |   |   |       |
| <b>SERVICE CHARGE</b>         |                      |   |   |                         |   |   |       |

MINIMUM MONTHLY SERVICE CHARGE \_\_\_\_\_  
(if applicable)

**7. Application of Charges**

The rates contained herein do not include applicable taxes and surcharges. These charges are listed on each customers bill as prescribed in Tariff Terms and Conditions N.J.A.C. 14:11-7.7(b).

**WASTE TYPE—BULKY**

**DISPOSAL CHARGE**

|                               | FREQUENCY OF SERVICE |   |   | PICK-UPS PER WEEK/MONTH |   |   | OTHER |
|-------------------------------|----------------------|---|---|-------------------------|---|---|-------|
|                               | 1                    | 2 | 3 | 4                       | 5 | 6 |       |
| CONTAINER SIZE in cubic yards |                      |   |   |                         |   |   |       |
| 1                             |                      |   |   |                         |   |   |       |
| 2                             |                      |   |   |                         |   |   |       |
| 3                             |                      |   |   |                         |   |   |       |
| 4                             |                      |   |   |                         |   |   |       |
| 5                             |                      |   |   |                         |   |   |       |
| 6                             |                      |   |   |                         |   |   |       |
| 7                             |                      |   |   |                         |   |   |       |
| 8                             |                      |   |   |                         |   |   |       |
| 9                             |                      |   |   |                         |   |   |       |
| 10                            |                      |   |   |                         |   |   |       |
| 11                            |                      |   |   |                         |   |   |       |
| 12                            |                      |   |   |                         |   |   |       |
| <u>OTHER</u>                  |                      |   |   |                         |   |   |       |
| <b>SERVICE CHARGE</b>         |                      |   |   |                         |   |   |       |

MINIMUM MONTHLY SERVICE CHARGE \_\_\_\_\_  
(if applicable)

**7. Application of Charges**

The rates contained herein do not include applicable taxes and surcharges. These charges are listed on each customers bill as prescribed in Tariff Terms and Conditions N.J.A.C. 14:11-7.7(b).

ON CALL SERVICE

DISPOSAL CHARGE

WASTE TYPE

|           |    | BULKY | COMPACTED | UNCOMPACTED |           | SERVICE Charge |
|-----------|----|-------|-----------|-------------|-----------|----------------|
|           |    |       |           | Front Load  | Rear Load |                |
| CONTAINER | 1  |       |           |             |           |                |
| SIZE in   | 2  |       |           |             |           |                |
| cubic     | 3  |       |           |             |           |                |
| yards     | 4  |       |           |             |           |                |
|           | 5  |       |           |             |           |                |
|           | 6  |       |           |             |           |                |
|           | 7  |       |           |             |           |                |
|           | 8  |       |           |             |           |                |
|           | 9  |       |           |             |           |                |
|           | 10 |       |           |             |           |                |
|           | 11 |       |           |             |           |                |
|           | 12 |       |           |             |           |                |
| OTHER     |    |       |           |             |           |                |

ADDITIONAL CHARGES (if any) \_\_\_\_\_

CONTAINER RENTAL (if applicable) \_\_\_\_\_

ROLLOFF SERVICE (Open Container)

| Table of Contents               | Page |
|---------------------------------|------|
| 1. DESCRIPTION .....            | 00   |
| 2. GENERAL PROVISIONS .....     | 00   |
| 3. JOINT USE/SHARING .....      | 00   |
| 4. TERMS OF PAYMENT .....       | 00   |
| 5. SPECIAL PROVISIONS .....     | 00   |
| A .....                         | 00   |
| B .....                         | 00   |
| C .....                         | 00   |
| 6. APPLICATION OF CHARGES ..... | 00   |

N.J.A.C. 14:11-7.6. Service is rendered via an open box type container which is rolled off or pulled on the chassis of a straight truck or semi-trailer by gravitational or mechanical means.

3. Joint Use/Sharing

Sharing of containers is prohibited unless prior arrangements are made with the collector concerning joint use of the container. Waste quantity and container rental and service charges will be applied based upon the percentage use of each customer.

4. Terms of Payment

5. Special Provisions (if applicable)

A.

B.

C.

6. Application of Charges

The rates contained herein do not include applicable taxes and surcharges. These charges are listed on each customers bill as prescribed in Tariff Terms and Conditions N.J.A.C. 14:11-7.7(b).

ROLLOFF SERVICE (Open Container)

1. Description

This section contains the general provisions and charges applicable to the provision of open container (limited and general) rolloff service.

2. General Provisions

Service is limited to the collection and disposal of acceptable commercial, industrial, institutional or bulky solid waste as defined in

ROLLOFF SERVICE (OPEN CONTAINER)

SERVICE CHARGE

|           | FREQUENCY OF SERVICE |   |   |   |   |   | OTHER (INCLUDES) (ON CALL) (if applicable) |
|-----------|----------------------|---|---|---|---|---|--|
|           | 1                    | 2 | 3 | 4 | 5 | 6 |  |
| CONTAINER |                      |   |   |   |   |   |  |
| SIZE IN   |                      |   |   |   |   |   |  |
| CUBIC     |                      |   |   |   |   |   |  |
| YARDS     |                      |   |   |   |   |   |  |
|           |                      |   |   |   |   |   |  |
|           |                      |   |   |   |   |   |  |
| OTHER     |                      |   |   |   |   |   |  |

Disposal Charge = Actual Disposal Charge at Designated Disposal facility.

Other Charges (includes rental, etc.)

6. Application of Charges

The rates contained herein do not include applicable taxes and surcharges. These charges are listed on each customers bill as prescribed in Tariff Terms and Conditions N.J.A.C. 14:11-7.7(b).

ROLLOFF SERVICE (CLOSED COMPACTED)

SERVICE CHARGE

|                               | FREQUENCY OF SERVICE |    |    |    |    |    | OTHER<br>(INCLUDES)<br>(ON CALL)<br>(if applicable) |
|-------------------------------|----------------------|----|----|----|----|----|---|
|                               | 1                    | 2  | 3  | 4  | 5  | 6  |   |
| CONTAINER SIZE IN CUBIC YARDS | 15                   | 20 | 25 | 30 | 35 | 40 |   |
| OTHER                         |                      |    |    |    |    |    |   |

Disposal Charge = Actual Disposal Charge at Designated Disposal facility.

Other Charges (includes rental, etc.)

MISCELLANEOUS SERVICE

|                                  |      |
|----------------------------------|------|
| Table of Contents                | Page |
| 1. DESCRIPTION .....             | 00   |
| 2. GENERAL PROVISIONS .....      | 00   |
| 3. BULKY WASTE COLLECTION .....  | 00   |
| 3A. TERMS OF PAYMENT .....       | 00   |
| 3B. APPLICATION OF CHARGES ..... | 00   |
| I. SERVICE CHARGE .....          | 00   |
| II. DISPOSAL CHARGE .....        | 00   |
| 4. SEASONAL SERVICE .....        | 00   |
| 4A. TERMS OF PAYMENT .....       | 00   |
| 4B. APPLICATION OF CHARGES ..... | 00   |
| 5. ADDITIONAL SERVICES .....     | 00   |
| 5A. DESCRIPTION .....            | 00   |
| 5B. TERMS OF PAYMENT .....       | 00   |
| 5C. SPECIAL PROVISIONS .....     | 00   |
| 5D. APPLICATION OF CHARGES ..... | 00   |

MISCELLANEOUS SERVICE

1. Description

This section contains the general provisions and charges applicable to the provision of solid waste collection services which are ancillary to a customer's main service and are not otherwise provided for in other classes of service.

2. General Provisions

Service is rendered on a limited basis.

BULKY WASTE COLLECTION

3. Bulky Waste Collection

The following subsection contains the general provisions and charges applicable to the provision of collection and removal services for bulky refuse as defined in Solid Waste Uniform Tariff definitions at N.J.A.C. 14:11-7.6 definitions section.

Individual items placed out for collection, but not placed in a rolloff, should not exceed a gross weight of \_\_\_\_\_

Waste placed out for collection should be neatly stacked or arranged as to allow for safe, orderly collection.

3A. Terms of Payment

3B. Application of Charges

The rates contained herein do not include applicable taxes and surcharges. These charges will be outlined on customers bills as prescribed in Tariff Terms and Conditions N.J.A.C. 14:11-7.7(b).

Service Charge/Disposal Charge

(applicable to On Call Service which requires special pick-ups for items or bulk too small for rolloff and too large for the hopper of a standard collection vehicle).

Items to be Collected

- 1 Construction/demolition debris
  - 2 stumps
  - 3 stoves
  - 4 etc. . . .
- List types of waste handled.

|         |      |          |
|---------|------|----------|
|         | Rate |          |
| Service |      | Disposal |

(Waste Directed to ( ) Disposal Facility)

4. Seasonal Service

The following subsection contains the general provisions and charges applicable to the provision of residential solid waste services on a limited basis and restricted to collection and removal of yard clippings and garden waste.

Service is provided on a seasonal basis from \_\_\_\_\_ to \_\_\_\_\_ of each year.

Containers must not exceed \_\_\_\_\_ (lbs. or gals.)

Waste other than that provided for herein, **WILL NOT BE REMOVED.**

4A. Terms of Payment

4B. Application of Charges

The rates contained herein do not include applicable taxes and surcharges. These charges will be outlined on customer bills as prescribed in Tariff Terms and Conditions N.J.A.C. 14:11-7.7(b).

I. Service Charges:

II. Disposal Charges:

5. Additional Service

The following subsection contains the general provisions and charges applicable to the provision of solid waste collection service not otherwise provided for in the tariff.

This section is reserved for solid waste utilities to outline those services not otherwise provided for in this document. General format procedures as described herein must be followed and all variations

must be submitted by formal petition to the Board for consideration and approval.

5A. Description of Service:

5B. Terms of Payment:

5C. Special Provisions (if applicable):

5D. The rates contained herein do not include applicable taxes and surcharges. These charges will be outlined on customer bills as prescribed in Tariff Terms and Conditions N.J.A.C. 14:11-7.7(b).

I. Service Charge:

II. Disposal Charge:

Waste Directed to ( ) Disposal Facility

**TRANSPORTATION**

(a)

**DESIGN AND RIGHT OF WAY  
DIVISION OF RIGHT OF WAY**

**Bureau of Acquisitions**

**Proposed Repeals and New Rules: N.J.A.C. 16:5**

Authorized By: Robert A. Innocenzi, Acting Commissioner,  
Department of Transportation.

Authority: N.J.S.A. 27:1A-5, 27:1A-6, 27:7-22, 27:7-44.6, 20:1-1 through 1-33 and the Uniform Relocation Assistance and Real Property Acquisition Policies Act of 1970, Pub. L. 91-646, as amended.

Proposal Number: PRN 1989-458.

Submit comments by October 5, 1989 to:

Charles L. Meyers  
Administrative Practice Officer  
Department of Transportation  
1035 Parkway Avenue  
CN 600  
Trenton, New Jersey 08625

The agency proposal follows:

**Summary**

The proposed new rules comply with the provisions of the amendments of the Uniform Relocation Assistance and Real Property Acquisition Policies Act of 1970, made by the Uniform Relocation Act Amendments of 1987 Title IV of the Surface Transportation and Uniform Relocation Act of 1987, (Pub. L. 100-17, 101 Stat. 246-256). The uniform regulations, policies and operating procedures governing real property acquisition are published in full in the Federal Register.

The rules provide the process to be used in the appraisal and acquisition of right of way required for transportation improvements. The proposed new rules provide the following:

Subchapter 1 provides the general definitions used within the rules concerning property acquisition.

Subchapter 2 establishes basic acquisition policies criteria for appraisals.

Subchapter 3 describes the procedure to be followed in the condemnation process concerning agricultural and horticultural land.

Subchapter 4 describes the organization and procedures establishing the exercise and delegation of powers to be followed.

**Social Impact**

The intent of proposed new rules N.J.A.C. 16:5 is to comply with the provisions of the amendments of the Relocation Assistance and Real Property Acquisition Policies Act of 1970, made by the Uniform Relocation Act Amendments of 1987 Title IV of the Surface Transportation and Uniform Relocation Act of 1987, (Pub. L. 100-17, 101 Stat. 246-256). The rules are necessary and vital to the Department's acquisition operation since they provide an orderly and efficient procedure to provide for the acquisition of property required for Department of Transportation transportation projects. The rules will have a beneficial impact and gener-

ally will not have or cause any adverse impact on those persons affected by the rules, relative to the previous rules.

**Economic Impact**

The economic impacts are mandated primarily by the provisions of changes in the Federal Laws of 1987. Since some of the changes are administrative and procedural, substantial savings to the State should result in the administration of the law, primarily in reduction of paperwork and uniformity of procedures. The new provisions involving agricultural and horticultural lands provide benefits to these classes of property owners which should result in a modest increase in costs which will vary in amounts on a case by case basis.

The Department, State and individuals affected may incur direct and indirect costs involved in the arrangement and coordination of the formal appeal process before an Administrative Law Judge where there are contested cases, which is currently the situation under the existing rules. Additionally, the person so affected may elect to be represented by legal counsel or other representative at that person's expense.

**Regulatory Flexibility Analysis**

The proposed new rules do not place any bookkeeping or recordkeeping requirements on small businesses as the term is defined by the Regulatory Flexibility Act, N.J.S.A. 52:14B-16 et seq. They do not place compliance requirements on small businesses involved in the acquisition process, by way of limiting what may or may not be reimbursable. The rules comply with the provisions of the Uniform Relocation Assistance and Real Property Acquisition Policies Act of 1970, the Uniform Relocation Act Amendments of 1987 and Title IV of the Surface Transportation and Uniform Relocation Assistance Act of 1987, Pub. L. 100-17, 101 Stat. 246-256.

Full text of the proposed repeal appears in the New Jersey Administrative Code at N.J.A.C. 16:5.

Full text of the proposal follows:

**CHAPTER 5  
ACQUISITIONS**

**SUBCHAPTER 1. GENERAL PROVISIONS**

16:5-1.1 Purpose

The rules in this chapter govern the acquisition of private property for a public purpose by the Department of Transportation.

16:5-1.2 Definitions

The following words and terms, as used in this chapter, have the following meanings, unless the context clearly indicates otherwise.

"Agency" means the State of New Jersey, Department of Transportation, which is condemning private property for a public purpose under the power of eminent domain.

"Appraisal" means a written statement independently and impartially prepared by a qualified appraiser setting forth an opinion of defined value of an adequately described property as of a specific date, supported by the presentation and analysis of relevant market information.

"Award" means the award of compensation made by the three commissioners appointed by the Court to determine the just compensation.

"Compensation" means the just compensation which the Agency is required to pay and the owner is entitled to receive, according to law, as the result of the condemnation of property.

"Condemnation" means the taking of private property for a public purpose under the power of eminent domain.

"Condemnee" means the owner of an interest in the private property being condemned for a public purpose under the power of eminent domain.

"Court" means the Superior Court of New Jersey.

"Initiation of negotiations" means the delivery of the initial written offer of just compensation by the Agency to the owner or the owner's representative to purchase the real property or such lesser interest as may be required.

"Judgement" means the adjudication by the court of any issue of fact or law, or both, arising under N.J.S.A. 20:3-1 et seq.

"Property" means land, or any interest in land and any building, structure or other improvement imbedded or affixed to land, and any

article so affixed or attached to such building, structure or improvement as to be an essential and integral part thereof; any article affixed or attached to such property in such manner that it cannot be removed without material injury to itself or to the property; and any article so designed, constructed, or specially adapted to the purpose for which such property is used that it is an essential accessory or part of such property; it is not capable of use elsewhere; and would lose substantially all its value if removed from such property.

"Salvage value" means the probable sale price of an item, if offered for sale on the condition that it will be removed from the property at the buyer's expense, allowing a reasonable period of time to find a person buying with knowledge of the uses and purposes for which it is adaptable and capable of being used, including separate use of serviceable components and scrap when there is no reasonable prospect of sale except on that basis.

"Tenant" means a person who has the temporary use and occupancy of real property owned by another.

"Uneconomic remnant" means a parcel of real property in which the owner is left with an interest after the partial acquisition of the owner's property, and which the Agency has determined it has little or no value or utility to the owner.

## SUBCHAPTER 2. BASIC ACQUISITION POLICIES

### 16:5-2.1 Basic acquisition policies

(a) The Agency shall make every reasonable effort to acquire real property expeditiously by negotiation.

(b) As soon as practicable, the owner shall be notified of the Agency's interest in acquiring the real property and the basic protections, including the Agency's obligation to secure an appraisal and to provide it to the owner.

(c) Before the initiation of negotiations, the real property to be acquired shall be appraised, except as provided in (c)1 below, and the owner, or the owner's designated representative, shall be given an opportunity to accompany the appraiser during the appraiser's inspection of the property.

1. An appraisal is not required if the owner is donating the property and releases the Agency from this obligation, or the Agency determines that an appraisal is unnecessary because the valuation problem is uncomplicated and the fair market value is estimated at \$2,500 or less, based on a review of available data.

(d) Before the initiation of negotiations, the Agency shall establish an amount which it believes is just compensation for the real property or such lesser rights to be acquired. The amount shall not be less than the approved appraisal of the fair market value of the property being taken, taking into account the value of allowable damages or benefits to any remaining property. The Agency shall make a written offer to the owner to acquire the property for the full amount believed to be just compensation. A copy of the approved appraisal shall be tendered to the property owner concurrent with the written offer.

1. The initial written purchase offer of just compensation shall include:

i. A statement of the amount offered as just compensation. In the case of a partial acquisition, the compensation for the real property to be acquired and the compensation for damages, if any, to the remaining real property shall be separately stated;

ii. A description and location identification of the real property and the interest in the real property to be acquired; and

iii. An identification of the buildings, structures, and other improvements (including removable building equipment and trade fixtures) which are considered to be part of the real property for which the offer of just compensation is made. Where appropriate, the statement shall identify any separately held ownership interest in the property, for example, a tenant owned improvement, and indicate that such interest is not covered by the offer.

(e) The Agency shall make reasonable efforts to contact the owner or the owner's representative and discuss its offer to purchase the property, including the basis for the offer of just compensation, and explain its acquisition policies and procedures, including its payment of incidental expenses in accordance with N.J.A.C. 16:5-2.5.

1. The owner shall be given reasonable opportunity to consider the offer and present material which the owner believes is relevant

to determining the value of the property and to suggest modification in the proposed terms and conditions of the purchase. The Agency shall consider the owner's presentation.

(f) Owners of improved properties where agreement is reached shall, upon acceptance and approval of the amount by the Commissioner, be eligible for an advance down payment up to 25 per cent of the purchase price, provided the amount of down payment does not exceed 75 per cent of their equity in the property.

(g) If the information presented by the owner, or a material change in the character or condition of the property, indicates the need for new appraisal information, or if a significant delay has occurred since the time of the appraisal(s) of the property, the Agency shall have the appraisal(s) updated or obtain a new appraisal(s). If the latest appraisal information indicates that a change in the purchase offer is warranted, the Agency shall promptly reestablish just compensation and offer that amount to the owner in writing. The updated appraisal should accompany the new fair market value offer.

(h) The Agency shall not advance the time of condemnation or defer negotiations or condemnation or the deposit of funds with the court, or take any other coercive action in order to induce an agreement on the price to be paid for the property.

(i) The purchase price for the property may exceed the amount offered as just compensation when reasonable efforts to negotiate an agreement at that amount have failed and an authorized Agency official approves such administrative settlement as being reasonable, prudent, and in the public interest.

(j) Before requiring the owner to surrender possession of the real property, the Agency shall pay the agreed purchase price to the owner, or in the case of condemnation, deposit with the court, for the benefit of the owner, an amount not less than the Agency's approved appraisal of the fair market value of such property, or the court award of compensation in the condemnation proceeding for the property. In exceptional circumstances, with the prior approval of the owner, the Agency may obtain a right of entry for construction purposes before making payment available to an owner.

(k) If the acquisition of only a portion of a property would leave the owner with an uneconomic remnant as defined at N.J.A.C. 16:5-1.1, the Agency shall have the right to acquire the uneconomic remnant along with the portion of the property needed for the project.

(l) If the Agency intends to acquire any interest in real property by exercise of the power of eminent domain, it shall institute formal condemnation proceedings and not intentionally make it necessary for the owner to institute legal proceedings to prove the fact of the taking of the real property.

(m) If the Agency permits a former owner or tenant to occupy the real property after acquisition for a short term or a period subject to termination by the Agency on short notice, the rent shall not exceed the fair market rent for such occupancy.

(n) If the owner of a real property improvement is permitted to retain it for removal from the project site, the amount to be offered for the interest in the real property to be acquired shall be not less than the difference between the amount determined to be just compensation for the owner's entire interest in the real property and the salvage value, as defined at N.J.A.C. 16:5-1.1, of the retained improvement.

### 16:5-2.2 Criteria for appraisals

(a) The format and level of documentation for an appraisal depend on the complexity of the appraisal problem. The Agency shall develop minimum standards for appraisals consistent with established and commonly accepted appraisal practice for those acquisitions which, by virtue of their low value or simplicity, do not require the in-depth analysis and presentation necessary in a detailed appraisal. A detailed appraisal shall be prepared for all other acquisitions. A detailed appraisal shall reflect nationally recognized appraisal standards, including, to the extent appropriate, the Uniform Appraisal Standards for Federal Land Acquisition. An appraisal must contain sufficient documentation, including valuation data and the appraiser's analysis of that data, to support his or her opinion of value. At a minimum, a detailed appraisal shall contain the following items:

1. The purpose and/or the function of the appraisal, a definition of the estate being appraised, and a statement of the assumptions and limiting conditions affecting the appraisal;

2. An adequate description of the physical characteristics of the property being appraised (and, in the case of a partial acquisition; an adequate description of the remaining property); a statement of the known and observed encumbrances, if any; title information; location; zoning; present use; an analysis of highest and best use; and at least a five year sales history of the property;

3. All relevant and reliable approaches to value consistent with commonly accepted professional appraisal practices. When sufficient market sales data are available to reliably support the fair market value for the specific appraisal problem encountered, the Agency, at its discretion, may require only the market approach. If more than one approach is utilized, there shall be an analysis and reconciliation of approaches to value that are sufficient to support the appraiser's opinion of value;

4. A description of comparable sales, including a description of all relevant physical, legal, and economic factors such as parties to the transaction, source and method of financing, and verification by a party involved in the transaction;

5. A statement of the value of the real property to be acquired and, for a partial acquisition, a statement of the value of the damages and benefits, if any, to the remaining real property, where appropriate; and

6. The effective date of valuation, date of appraisal, signature, and certification of the appraiser.

(b) To the extent permitted by applicable law, the appraiser shall disregard any decrease or increase in the fair market value of the real property caused by the project for which the property is to be acquired, or by the likelihood that the property would be acquired on the project, other than that due to physical deterioration within the reasonable control of the owner.

(c) The Agency shall establish criteria for determining the minimum qualifications of appraisers. Appraiser qualifications shall be consistent with the level of difficulty of the appraisal assignment. The Agency shall review the experience, education, training, and other qualifications of appraisers, including review appraisers, and utilize only those determined to be qualified.

(d) No appraiser or review appraiser shall have any interest, direct or indirect, in the real property being appraised for the Agency that would in any way conflict with the preparation or review of the appraisal. Compensation for making an appraisal shall not be based on the amount of the valuation. No appraiser shall act as a negotiator or real property agent for the Agency on real property which that person has appraised, except that the Agency may permit the same person to both appraise and negotiate an acquisition when the value of the acquisition is \$2,500 or less.

#### 6:5-2.3 Review of appraisals

(a) A qualified reviewing appraiser shall examine all appraisals to insure that they meet applicable appraisal requirements and shall, prior to acceptance, seek necessary corrections or revisions.

(b) If the reviewing appraiser is unable to approve or recommend approval of an appraisal as an adequate basis for the establishment of the offer of just compensation, and it is determined that it is not practical to obtain an additional appraisal, the reviewing appraiser may prepare a fully documented appraisal to support an approved or recommended value.

(c) The reviewing appraiser's certification of the recommended or approved value of the property shall be set forth in a signed statement which identifies the appraisal reports reviewed and explains the basis for such recommendation or approval. Any damages or benefits to any remaining property shall also be identified in the statement.

#### 16:5-2.4 Acquisition of tenant-owned improvements

(a) When acquiring any interest in real property, the Agency shall offer to acquire at least an equal interest in all buildings, structures, or other improvements located upon the real property to be acquired, which it requires to be removed or which it determines will be adversely affected by the use to which such real property will be put. This shall include any improvement of a tenant-owner who has the right or obligation to remove the improvement at the expiration of the lease term.

(b) Any building, structure, or other improvement, which would be considered to be real property if owned by the owner of the real property on which it is located, shall be considered to be real property.

(c) Just compensation for a tenant-owned improvement is the amount which the improvement contributes to the fair market value of the whole property, or its salvage value, whichever is greater.

(d) No payment shall be made to a tenant-owner for any real property improvement unless:

1. The tenant-owner, in consideration for the payment, assigns, transfers, and releases to the Agency, all of the tenant-owner's right, title, and interest in the improvement;

2. The owner of the real property on which the improvement is located disclaims all interest in the improvement; and

3. The payment does not result in the duplication of any compensation otherwise authorized by law.

(e) Nothing in this section shall be construed to deprive the tenant-owner of any right to reject payment under this section and to obtain payment for such property interests in accordance with other applicable law.

#### 16:5-2.5 Expenses incidental to transfer of title to the Agency

(a) The owner of the real property shall be reimbursed for all reasonable expenses the owner necessarily incurred for the following:

1. Recording fees, transfer taxes, documentary stamps, evidence of title, boundary surveys, legal descriptions of the real property, and similar expenses incidental to conveying the real property to the Agency. However, the Agency is not required to pay costs solely required to perfect the owner's title to the real property;

2. Penalty costs and other charges for prepayment of any preexisting recorded mortgage entered into in good faith encumbering the real property; and

3. The pro rata portion of any prepaid real property taxes which are allocatable to the period after the Agency obtains title to the property or effective possession of it, whichever is earlier.

(b) Whenever feasible, the Agency shall pay these costs directly so that the owner will not have to pay such costs and then seek reimbursement from the Agency.

#### 16:5-2.6 Certain litigation expenses

(a) The owner of the real property shall be reimbursed for any reasonable expenses, including reasonable attorney, appraisal, and engineering fees, which the owner actually incurred because of a condemnation proceeding, if:

1. The final judgment of the Court is that the Agency cannot acquire the real property by condemnation;

2. The condemnation proceeding is abandoned by the Agency other than under an agreed upon settlement; or

3. The Court having jurisdiction renders a judgment in favor of the owner in an inverse condemnation proceeding or the Agency effects a settlement of such proceeding.

#### 16:5-2.7 Donations

An owner whose real property is being acquired may, after being fully informed by the Agency of the right to receive just compensation for such property, donate such property or any part thereof, any interest therein, or any compensation paid therefor, to the Agency as such owner shall determine. The Agency is responsible for assuring that an appraisal of the real property is obtained unless the owner releases the Agency from such obligation, except as provided in N.J.A.C. 16:5-2.1(c)1.

#### 16:5-2.8 Condemnation

Where title is unmarketable, price agreement cannot be reached, or the owners cannot be located, the Agency will initiate condemnation proceedings in accordance with N.J.S.A. 20:3-1 et seq.

### SUBCHAPTER 3. AGRICULTURAL OR HORTICULTURAL LAND

#### 16:5-3.1 Authority

All provisions of this subchapter were adopted by the Commissioner of Transportation, pursuant to authority delegated at N.J.S.A. 20:3-29.1, which became effective July 17, 1986.

## 16:5-3.2 General provisions

The Agency, in condemning agricultural or horticultural land which is eligible for valuation, assessment and taxation under the Farmland Assessment Act of 1964, N.J.S.A. 54:4-23.1 et seq., shall compensate the condemnee for any loss of income resulting from the interference of the condemnation with the harvesting of any standing crops or other agricultural commodities, in an amount determined according to their appropriate time of harvest, and for the remainder of their average productive life, separate and apart from compensation for the fair market value of the land.

## 16:5-3.3 Eligibility requirements

To be considered eligible for compensation, a property must be eligible for valuation, assessment and taxation under the Farmland Assessment Act of 1964. The property must contain at least five acres, have been actively used for revenue producing agricultural or horticultural purposes over the past three years and have provided an income of at least five hundred dollars (\$500.00) in the aggregate and fifty dollars (\$50.00) per acre per year. Additionally, the property must be currently planted in crops and the condemnation proceedings must interfere with the harvesting of the crop. In the case of annual crops, it is the Agency's policy to allow the harvesting of the current crop, consistent with the requirement of the State's construction, as determined by the Agency.

## 16:5-3.4 Valuation of standing crop income

The anticipated annual acreage income from the standing crop over its remaining average productive life will be developed for the Agency by a qualified agricultural expert, as determined by the Agency. The specialist will estimate the average remaining productive life of the crop, the average anticipated gross income from the impacted crop and the anticipated expenses related to harvest and sale of the produce. The net anticipated income from the crop over the average remaining productive life of the crop will then be capitalized by the Agency into a present value.

## 16:5-3.5 Negotiations

The appraised valuation of the crop will be tendered to the condemnee concurrent with, but separate and apart from, the fair market value real estate offer. Where prolonged negotiations have allowed one or more harvest seasons to pass, where the condemnee has had the opportunity to reap the crops, or upon the Agency taking possession of the property pursuant to a condemnation action, the valuation of the standing crop will be updated to reflect the reduction in the average remaining productive life and also to eliminate crop income realized by the condemnee for harvesting the taken property.

## 16:5-3.6 Condemnation

Offers of compensation tendered under this subchapter will not be considered a part of the valuation of the real property for the purpose of acquisition of the real property.

## 16:5-3.7 Appeals

The condemnee may appeal the Agency's determination as to amount of, or eligibility for, payments under this subchapter, in accordance with N.J.A.C. 16:6-3.3.

## SUBCHAPTER 4. ORGANIZATION AND PROCEDURES

## 16:5-4.1 Exercise of powers

The Department of Transportation may exercise, on behalf of any county, municipality, or other entity, as the case may be, the powers granted to these agencies under N.J.S.A. 20:3-1 et seq.

## 16:5-4.2 Delegation of powers

Ordinarily, the Bureau of Acquisition and Appraisals, within the Division of Right of Way, will be responsible for administering these rules and the attendant Federal and State laws, on behalf of the Commissioner of Transportation.

## 16:5-4.3 Federal law

The administration of acquisition procedures shall be provided consistent with applicable Federal laws and regulations.

(a)

**RIGHT OF WAY  
DIVISION OF TRAFFIC ENGINEERING AND LOCAL  
AID  
BUREAU OF LOCAL AID DISTRICT OPERATIONS  
New Jersey Bridge Rehabilitation and Improvement  
Fund: State Aid to Counties and Municipalities  
Proposed New Rules: N.J.A.C. 16:21A**

Authorized By: Robert A. Innocenzi, Acting Commissioner,  
Department of Transportation.

Authority: N.J.S.A. 27:1A-5, 27:1A-6, 27:7-13, 7-47 and the New Jersey Bridge Rehabilitation and Improvement Bond Act of 1983, P.L.1983, c.363.

Proposal Number: PRN 1989-451.

Submit comments by October 5, 1989 to:

Charles L. Meyers  
Administrative Practice Officer  
Department of Transportation  
1035 Parkway Avenue  
CN 600  
Trenton, New Jersey 08625

The agency proposal follows:

**Summary**

Under the "sunset" and other provisions of Executive Order No. 66 (1978), N.J.A.C. 16:21A, New Jersey Bridge Rehabilitation and Improvement Fund: State Aid to Counties and Municipalities, expired on August 20, 1989. The Bureau of Local Aid Highway Design has reviewed these rules and has determined them to be necessary, reasonable, and proper for the purpose of which they were originally promulgated. Under the provisions of N.J.A.C. 1:30-4.4, the Department is proposing the expired rules as new rules, with technical changes at N.J.A.C. 16:21A-1.3.

These rules were proposed to implement provisions and purposes of the New Jersey Bridge Rehabilitation and Improvement Bond Act of 1983; P.L. 1983, c. 363, effective October 4, 1983. The Department in compliance with the provisions of the Bond Act and applicable rules must ensure and maintain a safe and reliable transportation system. Additionally, a safe and reliable system of rail and road transportation is essential to the well-being of the citizens and the economy of the State.

The funds under the Act are appropriated by the Legislature as the State's share of the cost for construction, reconstruction, replacement, improvement, repair or rebuilding of bridges carrying county or municipal roads, including railroad overhead bridges.

The subchapters are summarized as follows:

N.J.A.C. 16:21A-1 outlines the general provisions of the regulations. N.J.A.C. 16:21A-2 prescribes the responsibility of the local government in the preparation of plans and specifications.

N.J.A.C. 16:21A-3 provides the procedure to be followed in the awarding of contracts.

N.J.A.C. 16:21A-4 describes the cost sharing or cost participation by the responsible agency.

N.J.A.C. 16:21A-5 establishes guidelines concerning audits to be undertaken by counties and municipalities which are the recipients of State grants and aid programs and Federal pass-through funds.

The Department therefore proposes as new rules expired N.J.A.C. 16:21A with amendments in compliance with P.L. 1983, c. 363, the New Jersey Bridge Rehabilitation and Improvement Bond Act of 1983.

**Social Impact**

The proposed new rules will provide a source of added revenues to the State and local government in the rehabilitation and improvement of bridges. The rules will also assist in providing a safe and reliable system of rail and road transportation which is essential to the well being of the citizens and the economy of the State.

**Economic Impact**

The Department and local government will incur direct and indirect cost for its workforce in the processing of plans and specifications, cost of engineering, contractual agreements and cost sharing regarding the specific rehabilitation or improvement project. Audit costs incurred by the municipality will be borne by the municipality.

**Regulatory Flexibility Statement**

The proposed new rules do not place any bookkeeping, recordkeeping or compliance requirements on small businesses as the term is defined by the Regulatory Flexibility Act, N.J.S.A. 52:14B-16 et seq. The rules primarily affect counties and municipalities.

Full text of the proposed new rules may be found in the New Jersey Administrative Code at N.J.A.C. 16:21A.

Full text of N.J.A.C. 16:21A-1.3, reflecting technical changes from the expired rule, follows:

**16:21A-1.3 Standards**

(a) The proposed bridge improvement projects shall conform to the design criteria of the appropriate American Association of State Highway and Transportation Officials publication or New Jersey Department of Transportation Standards listed below. Any exceptions to these design criteria must be justified by the local engineer to be in the public interest.

1. New Jersey Department of Transportation for Resurfacing, Restoration and Rehabilitation of Highways and Streets;
2. A Policy on Geometric Design of Highways and Streets;
3. Standard Specifications for Highway Bridges.

(b) Construction and materials shall conform with the current New Jersey State Department of Transportation Standard Specifications for Road and Bridge Construction.

**EDUCATION****(a)****STATE BOARD OF EDUCATION****Provisional Certification of First-Year Teachers****Proposed Repeals and New Rules: N.J.A.C. 6:11-5.1 and 5.2****Proposed Repeal: N.J.A.C. 6:11-5.3****Proposed Recodifications with Amendments:****N.J.A.C. 6:11-5.4, 5.5, 5.6 and 5.7****Proposed Amendment: N.J.A.C. 6:11-7.2**

Authorized By: Saul Cooperman, Commissioner, Department of Education; Secretary, State Board of Education.

Authority: N.J.S.A. 18A:1-1, 18A:4-15, 18A:6-7, 18A:6-34, 18A:6-38, 18A:7-38 and 18A:26-10.

Proposal Number: PRN 1989-464.

Submit comments by October 5, 1989 to:

Irene Nigro, Rules Analyst  
State Department of Education  
225 West State Street, CN 500  
Trenton, New Jersey 08625

The agency proposal follows:

**Summary**

In 1984, the State Board of Education adopted major changes in rules governing the preparation and certification of teachers. These changes included the revision of standards for approved college teacher education programs as well as the creation of an alternate preparation route to replace emergency certification procedures. At the time these reforms were adopted, the Department was urged to monitor the new system in order to determine any additional changes that should be made after three to five years of implementation.

Indeed, in each of the past four years the Department has monitored the system carefully and has presented several public reports on new teachers who have come through the system, their scores on certification tests, and aspects of their preparation. Independent organizations, such as the Council on Basic Education, also have conducted and published studies of the system.

The information gathered over the past four years has underscored the soundness of the system of "traditional" and "alternate" routes. The juxtaposition of two approaches to attracting and training teachers has produced a healthy competition, and the Department remains strongly committed to supporting and encouraging both.

In nearly all significant respects, the two routes are comparable in their minimum requirements, though different in format. Candidates in both routes must receive a liberal education, complete an appropriate academic major and pass a State subject test. In addition, candidates in both routes must complete study of a common body of professional knowledge. The topics for this requirement were defined as part of an elaborate public process by a panel of nationally recognized educators, under the chairmanship of Ernest Boyer, as those essential to the preparation of teachers for certification. "Traditional route" candidates complete this study before employment as part of their college programs, while "alternate route" candidates do so in conjunction with employment.

However, a difference exists with respect to the way in which the practical classroom teaching competencies of the two types of candidates are developed and assessed for purposes of standard certification. This difference arises from the fact that "alternate route" candidates must spend their first year of employment working under provisional certification as salaried full-time teachers. During this extended immersion, their classroom teaching competencies are developed and evaluated by district professionals who work in daily proximity to the candidates as members of candidates' support teams. Only after completing this extensive and intensive experience are alternate candidates eligible for standard certification.

"Traditional" candidates, however, are not required as beginning teachers to serve a provisional year, nor are they provided local mentors, developmental support or certification evaluations. They are assumed not to need them by virtue of their having completed practice teaching experiences in college. Therefore, they are certified permanently before they ever actually serve as employed teachers and, when they are hired for the first time as "traditionally prepared" beginning teachers, they need not receive any more support than is provided to experienced teachers.

College practica are an important and valuable part of "traditional" preparation programs. Candidates who have completed these practice teaching experiences should be permitted to take over their initial jobs without the intensive induction that inexperienced "alternate route" teachers must complete before they assume full responsibility for a classroom. However, college practica do not obviate the need for support and assessment of "traditionally" prepared teachers during their first year of employment.

It is worth noting that New Jersey remains one of only three states in the country that allow "traditionally prepared" teacher candidates to earn permanent licenses before they have ever served as employed teachers. A growing number of states has moved toward the establishment of district-based support programs as a primary means of developing and assessing the classroom competency of newly employed beginning teachers for permanent certification. The State Board of Education's recently adopted policies for certifying school principals and substance awareness coordinators also require "provisional residencies" of all applicants.

Clearly, all beginning teachers are vulnerable, regardless of their academic preparation, to the possibility that they will not succeed once they are employed. The new staff member's chances of success are enhanced, however, when his or her employing organization recognizes his or her special needs and when principals and other supervisors are committed to providing special support and direction. They are enhanced as well when the beginning teacher is able to turn for advice and assistance to an experienced colleague who occupies a similar position.

Certain types of training simply are better accomplished as an integral part of initial employment. Among the most obvious types is the development of performance competency. In addition, the State's decision to issue or not issue a permanent license is more valid when it takes into account actual, rather than just "practice," job performance over a reasonably extended period.

New Jersey's experience of the past four years has underscored the importance of these basic principles. Both types of beginning teachers, "alternate" and "traditional," have proven vulnerable to the possibility of not succeeding on the job. "Alternate" teachers have significantly lower first-year attrition rates than other beginning teachers. Observers of the Provisional Teacher Program, as well as provisional teachers themselves, most often attribute this success to the support provided by mentor teachers and the special supervision provided by principals and other supervisors. Yet, as stated above, "traditionally prepared" first-year teachers are not provided this support despite their relatively high attrition rates.

In addition, those first-year "alternate" teachers who do not succeed are given a second opportunity and, if they do not succeed after two years,

they are denied permanent certification and prevented from trying again. The larger proportions of "traditionally prepared" first-year teachers who do not succeed may continue to try indefinitely, and they retain permanent certificates even if they ultimately never achieve success given multiple opportunities in various positions.

Based on its careful review of the system over the past five years, the Department believes that it is essential to the public interest that all beginning teachers who are first-time candidates for New Jersey certification be required to serve as provisionally certified teachers during their first year of employment. During that year, they should receive the same observations and evaluations from local support teams that alternate candidates now receive. Like "alternate" candidates, these other first-year teachers should be eligible for permanent certification only at the end of the provisional year.

Under the proposed approach, "traditional" candidates would continue to be able to complete the following, prior to employment, at in-State and out-of-State college programs: liberal education, subject matter preparation, professional education coursework and practice teaching. Upon graduating and passing the NTE, which is an exam administered nationwide to New Jersey applicants for teacher certification, these college program graduates would receive a Certificate of Eligibility with Advanced Standing. This document would be similar to the Certificate of Eligibility that is used to qualify "alternate" candidates to seek provisional employment. However, it would indicate those aspects of professional training that the candidate completed as part of a college program.

When offered employment, the college program graduate would be issued a one-year provisional certificate. Unlike alternate candidates, college program graduates would be able immediately to assume full responsibility for a classroom and would be exempted from the month-long seminar practicum that alternate candidates must complete before they take over an assignment. They would be exempted as well from the 200 hours of coursework required of alternate candidates, having already completed such study in their college programs.

However, the employing district would have to form a Support Team to conduct the same number of developmental observations and formal certification evaluations that are required for "alternate" first-year teachers. At the end of the "traditional" candidate's provisional year, the principal in charge of the support and evaluation teams would, as an agent of the state Licensing system, recommend that the State Board of Examiners: 1. certify the candidate permanently; or 2. extend his or her provisional certificate a second year; or 3. terminate consideration of the candidate for certification. These procedures are already specified in the Code, as are due process procedures for contested certification recommendations (see: N.J.A.C. 6:11-5.5(c)).

Clearly, standard teaching certificates would be issued more selectively under the proposed system. Yet, because the provisional experience combines rigorous evaluation with support and development, it actually helps to enhance job security. In New Jersey, provisional teachers leave their jobs up to four times less frequently than other first-year teachers. As indicated above, observations of the two systems suggest strongly that this difference is attributable largely to the provisional support and development program of the alternate route.

#### Implementation of the Proposed System

The proposed provisional support program would be required beginning September 1991 for all candidates applying for a New Jersey instructional certificate for the first time. Therefore, it would apply to this year's sophomore classes of in-State and out-of-State college preparation programs, and to reciprocity applicants applying after September 1991.

It would not apply, either retrospectively or in the future, to any applicant for a New Jersey instructional endorsement who already holds another New Jersey instructional endorsement. The experiences of the provisional support program are generic and not endorsement-specific. Therefore, they should not be required of persons who have completed the experiences or their equivalent in prior service.

#### Other Refinements

Various independent studies of the current system and the Department's own observations of that system indicate a need to adjust the number of formal developmental observations that provisional teachers receive. Currently, alternate candidates must receive 15 formative observations and three evaluations during their provisional year. These requirements were recommended five years ago by a panel and the specific number of 15 formative observations was arrived at arbitrarily. This requirement was intended to err on the side of stringency.

Experience of the past several years suggests that this number is more than is minimally needed, and the Department recommends that it be reduced to at least nine. This change will allow district teams the flexibility to provide more than the minimum number of formal observations in those cases where more is needed. Responsibility for these nine "coaching" observations are distributed among members of the first-year teacher's Support Team, which must include the principal and one mentor teacher but may include other persons as well at the discretion of the principal.

The requirement of three formal evaluations would be continued, and these must be conducted by certified supervisors.

#### Partnerships

Primary responsibility for operating provisional support program must be pinpointed with local district professionals, those persons who work in daily close proximity to first-year teachers, under the auspice of the new teacher's employing organization.

At the same time, the current rules governing the provisional program encourage partnerships with academic institutions. The rules require districts to show evidence of having sought the involvement of colleges in their local programs (N.J.A.C. 6:11-5.4(c)) and, unless they are unable to arrange collegiate participation, to appoint a college faculty member to the local Support Team of each provisional first-year teacher (N.J.A.C. 6:11-5.5(c)).

These same rules would be retained in the proposed amendment concerning local support programs for "traditionally" prepared first-year teachers. In addition, the Department has awarded six grants totaling \$350,000 to consortia of school districts and colleges to identify ways of maximizing the potential for partnership that is embodied in these rules. The six consortia, each of which is developing its recommendations under the coordination of a lead district, involves 47 school districts and five New Jersey colleges statewide. The resultant models will be complete prior to the implementation of the proposed amendments and they will be considered as a means of guiding such implementation and of improving the current system.

#### Proposed Rule Modifications

At N.J.A.C. 6:11-5, State Approved District Training Programs, the proposal includes repeal, recodification, amendments and new rule which establish requirements for the provisional and standard certification of teachers. In addition, the rules that currently govern provisional support programs for alternate route candidates would be amended to apply to all first-time applicants for New Jersey instructional certificates and refined in accordance with the recommendations presented above.

At N.J.A.C. 6:11-7.2, Admission, retention and graduation of students the proposed amendment would clarify that completion of an approved college program would result in issuance of a Certificate of Eligibility with Advanced Standing.

#### Social Impact

The proposed amendments and new rules will directly affect the approximately 1000 inexperienced first-year teachers who are hired annually in New Jersey public schools. The primary effect of the proposed amendments and new rules will be to provide new teachers with on-the-job support and supervision that will help them to succeed. It is likely that this increased success will produce lower attrition rates among these teachers. Over the past four years, the alternate certification route, which already provides first-year support, has helped to generate attrition rate that are two to four times lower than those of beginning teachers who do not receive such support. The public will benefit from a more stable and successful force of first-year teachers.

The proposed amendments and new rules will also deny permanent teaching licenses to the relatively few first-year teachers who are unable to perform successfully despite increased support and supervision. The general public will benefit from the screening of those new teachers who cannot achieve a minimal level of success.

#### Economic Impact

The proposed amendments and new rules would not have a significant economic impact on the local districts since the cost of the certification training is funded by candidate fees. The program will utilize existing administrative resources of the public school districts. As noted in the Summary above, the state Department of Education has awarded grants totaling \$350,000 to consortia of school districts and colleges to explore ways in which the support and supervision of first-year teachers might be improved qualitatively.

The proposed mentoring services would be funded by a fee paid by the first-year teacher. This fee, which is now set in the alternate certifica

ion route by local districts with state Department of Education coordination, is currently \$900 per year.

Since the program is fiscally self sustaining, there is no significant direct cost to the public.

#### Regulatory Flexibility Statement

A regulatory flexibility analysis is not required because the proposed rules and amendments do not impose reporting, recordkeeping or other compliance requirements on small businesses, but impact solely upon New Jersey school districts and schools operated by the New Jersey Department of Education.

**Full text** of the proposal follows (additions shown in boldface **thus**; deletions shown in brackets [thus]).

### SUBCHAPTER 5. [BASIS FOR ISSUANCE OF STANDARD TEACHER CERTIFICATION] REQUIREMENTS FOR INSTRUCTIONAL CERTIFICATION

#### [6:11-5.1 General procedure

(a) New Jersey standard instructional certificates are issued to applicants who:

1. Possess a baccalaureate degree from an accredited institution, who have completed approved teacher education programs in New Jersey colleges and universities (see N.J.A.C. 6:11-7) or equivalent programs in out-of-State institutions approved for teacher education by the State Department of Education of the state in which the college is located and who have passed a test of subject matter knowledge in the appropriate subject teaching field(s) or a test of general knowledge for the elementary and nursery endorsements; or

2. Hold a Bachelor's degree from an accredited institution, have passed a State test of subject matter knowledge in the teaching field(s) or a State test of general knowledge for the elementary and nursery endorsements and have completed a State-approved alternative training program as described in N.J.A.C. 6:11-5.3 (except in fields as noted in N.J.A.C. 6:11-8.3(c)). In order to be eligible to take a subject field test, the applicant must have completed at least 30 semester hours in a coherent major or five years of experience in the subject field.

(b) State-approved alternative training programs are not authorized in the fields of teacher of the handicapped, teacher of the deaf and hard of hearing, teacher of the blind and partially sighted, bilingual education, English as a second language and certain vocational fields (N.J.A.C. 6:11-8.3(c)). The professional preparation of candidates in these fields shall be assessed on the basis of having completed an approved college program (N.J.A.C. 6:11-7) or on the basis of transcript evaluation (N.J.A.C. 6:11-8).]

#### [6:11-5.2 Reciprocity

(a) Applicants may qualify for a standard New Jersey teachers certificate in one or more of the comprehensive or single field endorsements listed in N.J.A.C. 6:11-6.2 by successful completion of one of the following:

1. Completion of a college teacher education program, which is included in the NASDTEC Certification Reciprocity System, issued by the National Association of State Directors of Teacher Education and Certification, designating approval as meeting the national standards described in Standards for State Approval of Teacher Education.

2. Completion of an appropriate out-of-State teacher education program approved by the National Council for Accreditation of Teacher Education (NCATE), provided that the program is approved by the Commissioner of Education as meeting New Jersey requirements in the required areas of general background, professional education, and subject specialization as stated in N.J.A.C. 6:11-7.

3. Completion of an appropriate teacher education program including student teaching, approved by the state department of education in the state in which the college is located, (but not appearing on the NCATE or NASDTEC list of accredited colleges and approved programs), provided the program is approved by the Commissioner as meeting the minimum standards outlined in Standards for State Approval of Teacher Education (see N.J.A.C. 6:11-7).

4. Completion of a baccalaureate or postbaccalaureate teacher preparation program in one of the states party to the Agreement, approved by the state department of education of the state in which the college is located, provided the college and program are approved, the specific program completed by the applicant was approved on or after January 1, 1964, and the state in which the college is located would issue the applicant a comparable certificate.

5. Completion of 27 months of appropriate teaching experience in states in the Agreement, within seven years prior to applying for a certificate in another state in the Agreement, a comparable valid standard or advanced certificate, still in force, issued by one of the states in the Agreement, and the appropriate degree required for the certificate in the receiving state.

(b) All applicants who present satisfactory preparation, experience, or certificates from other states must also pass a State test of subject matter or a State test of general knowledge for elementary and nursery education in order to receive a standard New Jersey certificate. All such applicants shall be eligible to take the test on the basis of preparation and experience by another state.]

#### 6:11-5.1 Requirements for the provisional certificate

(a) To be eligible for the provisional certificate in instructional fields, the candidate shall:

1. Hold a bachelor's degree from an accredited college or university;
2. Complete at least 30 credits in a coherent major appropriate to the instructional field;
3. Pass a State test of subject matter knowledge for fields of teaching specialization or a test of general knowledge for the elementary endorsement; and
4. Obtain and accept an offer of employment in a position that requires instructional certification.

(b) Candidates who complete the requirements in (a)1 through 4 above shall be issued Certificates of Eligibility which will permit them to seek provisional employment in positions requiring instructional certification.

(c) Certificates of Eligibility with Advanced Standing shall be issued to all persons who meet the test requirement pursuant to (a)3 above and who have completed one of the following programs of teacher preparation:

1. A New Jersey college program, graduate or undergraduate, approved by the State Department of Education for the preparation of teachers pursuant to N.J.A.C. 6:11-7;
2. A college preparation program included in the interstate certification reciprocity system of the National Association of State Directors of Teacher Education and Certification (NASDTEC);
3. An out-of-State teacher education program approved by the National Council for the Accreditation of Teacher Education (NCATE);
4. A teacher education program approved for certification by the state department of education in one of the states party to the Interstate Agreement on Qualifications of Educational Personnel, provided the program was completed on or after January 1, 1964 and the state in which the program is located would issue the candidate a comparable certificate;

5. An out-of-State teacher education program not approved by NASDTEC or NCATE but approved by the state department of education in which the program is located and approved by the Secretary of the New Jersey State Board of Examiners as meeting the standards outlined in N.J.A.C. 6:11-7; or

6. At least 27 months of appropriate teaching experience in a state party to the Agreement within seven years prior to applying for a certificate in another state in the Agreement, and a comparable and valid standard or advanced certificate, still in force, issued by one of the states in the Agreement.

#### 6:11-5.2 Requirements for the standard certificate

(a) To be eligible for the standard certificate in instructional fields, the candidate shall:

1. Possess a provisional certificate pursuant to N.J.A.C. 6:11-5.1; and
2. Complete a State-approved district or nonpublic school training program pursuant to N.J.A.C. 6:11-5.3 through 5.5 while employed

provisionally in a position requiring the relevant endorsement to the instructional certificate.

(b) Candidates who hold standard New Jersey instructional certificates shall be issued additional standard endorsements in areas where they meet provisional certification requirements without having to meet the requirements in (a)1 and 2 above.

[6:11-5.3 Requirements for provisional certification for State-approved alternative training programs

(a) The State-approved training program is an alternative to the college teacher preparation training program as a means to acquire standard certification. These training programs may be offered in all instructional fields except bilingual education, English as a second language, teacher of the handicapped, teacher of the deaf and hard of hearing, teacher of the blind and partially sighted, and certain vocational fields (N.J.A.C. 6:11-8.3(c)). To participate in a State-approved alternative training program, the candidate shall:

1. Possess a Bachelor's degree (except as noted in N.J.A.C. 6:11-6.3(c)).

2. Pass a State test of subject matter knowledge in the teaching field. For the elementary and nursery endorsements, the candidates shall pass a State test of general knowledge. In order to be eligible to take a subject field test, the applicant must have completed at least 30 semester hours in a coherent major or five years of experience in the subject field; and

3. Have been offered employment in a school approved by the Commissioner of Education at the recommendation of the State Board of Examiners to offer a certification training program.

(b) The provisional certificate is of one-year duration and will be issued by the State Board of examiners to participants in a State-approved training program. The standard certificate will be issued by the State Board of Examiners upon satisfactory completion of the program.

(c) The Board of Examiners shall have the right to reject the application of any candidate who is judged not to meet academic requirements comparable to those for students enrolled in New Jersey college teacher preparation programs.

(d) Provisional certificates shall not be granted to teachers of bilingual education, English as a second language, the handicapped, deaf or hard of hearing, or blind or partially sighted.]

6:11-[5.4]5.3 Requirements for State-approved [plans] district training programs

(a) Each district, school or consortium [of schools] seeking to hire a provisional teacher must submit a plan to the Department of Education and receive approval in accordance with the same procedures used for initial approval of collegiate preparation programs.

(b)-(d) (No change.)

(e) The State Department of Education shall issue a standard training program plan which districts may agree to implement in lieu of developing an original plan pursuant to (a) above.

[6:11-5.5 Requirements for State-approved alternative training programs]

[(a)] (f) Each State-approved [alternative] district training program shall provide essential knowledge and skills to provisional teachers through the following phases of training:

1. A full-time seminar/practicum of no less than 20 days duration which takes place prior to the time at which the provisional teacher takes full responsibility for a classroom. This seminar/practicum shall provide formal instruction in the essential areas for professional study listed in N.J.A.C. 6:11-8.2. It should introduce basic teaching skills through supervised teaching experiences with students. The seminar and practicum components of the experience shall be integrated and shall include an orientation to the policies, organization and curriculum of the employing district. **This requirement shall not apply to provisional teachers who are holders of Certificates of Eligibility with Advanced Standing pursuant to N.J.A.C. 6:11-5.1(c).**

2. A period of intensive on-the-job supervision beginning the first day on which the provisional teacher assumes full responsibility for a classroom and continuing for a period of at least [ten] 10 weeks. During this time, the provisional teacher shall be visited and critiqued no less than one time [per week] every two weeks by members of a Professional Support Team (see [N.J.A.C. 6:11-5.5(b)] (h) below and shall be observed and formally evaluated at the end of five weeks and at the end of [five weeks and at the end of ten] 10 weeks by the appropriately certified members of the team. [During this same period, formal instruction shall be continued in essential areas listed in N.J.A.C. 6:11-8.2(a) and shall emphasize the topics of student assessment, development, and learning, curriculum and school/classroom organization.] At the end of the 10-week period, the provisional teacher shall receive a formal written progress report from the chairperson of the Support Team.

3. An additional period of continued supervision and evaluation of no less than 20 weeks duration. During this period, the provisional teacher shall be visited and critiqued at least [once per month] four times and shall be observed formally and evaluated at least twice. No more than two months shall pass without a formal observation. [Formal instruction shall continue in the essential areas listed in N.J.A.C. 6:11-8.2(a).] Opportunities shall be provided for the provisional teacher to observe the teaching of experienced colleagues.

[(b)] (g) Approximately 200 hours of formal instruction in the following topics shall be provided in all three phases of the program combined. **This requirement shall not apply to provisional teachers who are holders of Certificates of Eligibility with Advanced Standing pursuant to N.J.A.C. 6:11-5.1(c).**

i. Curriculum: Studies designed to foster an understanding of the curriculum taught and the assessment of teaching, including topics such as the following: the organization and presentation of subject matter, the development and use of tests and other forms of assessment, the evaluation and selection of instructional materials and the appropriate use of textbooks and teachers' guides, the use and interpretation of standardized tests and teacher-developed instruments, the reading process and other language art skill development appropriate to the field of specialization and grade level, and a knowledge of techniques and materials for fostering the development of reading and language arts skills.

ii. Student development and learning at all levels: Studies designed to foster an understanding of students, their characteristics as individuals, and the ways in which they learn, including topics such as: student interests, motivation, preventing classroom disruption, creating a healthy learning climate, individual and group learning, language development, individual differences, and the role of technology in early learning.

iii. The classroom and the school: Studies designed to foster an understanding of the school as a social unit and classroom management, including such topics as: the bureaucratic/social structure of public education, the making of teaching decisions, allocation of instructional time, setting of priorities, pacing of instruction, setting of goals, questioning techniques, student practice and independent work.

[(c)] (h) Training and supervision of provisional teachers in State approved alternative programs shall be provided by a Professional Support Team comprised of a school principal, an experienced mentor teacher, a college faculty member, and a curriculum supervisor. Districts or schools which do not employ curriculum supervisors or have been unable to establish a relationship with a college should provide for comparable expertise on the team. The school principal shall serve as chairperson of the team.

[(d)] In accordance with the provisions of N.J.S.A. 18A:26-8, all provisional teachers must pass an examination in physiology and hygiene in order to receive standard certification.]

[(e)] (i) The State Department of Education shall coordinate the training efforts of districts and shall establish regional programs for provisional teachers. The Department shall provide orientation programs for Support Team Members.

6:11-[5.6] **5.4** Requirements for the evaluation of provisional teachers

(a) Provisional teachers shall be observed and evaluated by appropriately certified Support Team Members as described in N.J.A.C. 6:11-[5.5] **5.3**.

(b) (No change.)

(c) The State Department of Education shall devise standardized criteria and forms for a final comprehensive evaluation of each provisional teacher, conducted at the end of the provisional period by appropriately certified Support Team Members. [Teachers who participate in the observation process shall not participate in decisions which might have a bearing on the future employment or certification of provisional teachers.]

(d) **Mentor teachers shall not participate in any way in decisions which might have a bearing on the employment or certification of provisional teachers. They shall not assess or evaluate the performance of provisional teachers unless they are appropriately certified administrators. Interactions between provisional teachers and experienced mentor teachers are formative in nature and considered a matter of professional privilege. Mentor teachers shall not be compelled to offer testimony on the performance of provisional teachers.**

6:11-[5.7] **5.5** Recommendation for certification of provisional teachers

(a) At the conclusion of the [alternative] **State-approved district** training program, the chairperson of the Support Team shall prepare a comprehensive evaluation report on the provisional teacher's performance. This report shall be submitted by the Chairperson directly to the Bureau of Teacher Preparation and Certification and shall contain a recommendation as to whether or not a standard certificate should be issued to the provisional teacher.

(b) (No change.)

(c) The final report on each provisional teacher shall include one of the following recommendations:

1. (No change.)

2. **Insufficient:** Recommends that a standard certificate not be issued but that the candidate be allowed to seek entry on one more occasion in the future into a State-approved **district** training program; or

3. **Disapproved:** Recommends that a standard certificate not be issued and that the candidate not be allowed to enter into a State-approved **district** training program.

(d) (No change.)

(e) If the provisional teacher disagrees with the chairperson's recommendation, the provisional teacher may, within 15 days of receipt of the evaluation report and certification recommendation, submit to the chairperson written materials documenting the reasons why the provisional teacher believes standard certification should be awarded or a **recommendation of insufficient granted**. The chairperson shall forward all such documentation to the Bureau of Teacher Preparation and Certification along with the evaluation report and recommendation concerning certification. **The provisional teacher may contest the unfavorable recommendation pursuant to N.J.A.C. 6:11-3.25.**

(f) **Candidates who receive a recommendation of "disapproved" or two or more recommendations of "insufficient" may petition the State Board of Examiners for approval of additional opportunities to seek provisional employment in districts other than those in which they received unfavorable recommendations. The candidate shall be responsible for demonstrating why he or she would be likely to succeed if granted the requested opportunity. Disapproval of any candidate's request by the State Board of Examiners may be appealed to the Commissioner of Education.**

6:11-7.2 Admission, retention, and graduation of students

(a) Teacher preparation programs are those curricula which lead to a recommendation for a New Jersey [instructional certificate] **Certificate of Eligibility with Advanced Standing in instructional fields pursuant to N.J.A.C. 6:11-5.1**, irrespective of the organizational unit of the college by which the curriculum is offered. Formal admission to teacher preparation programs shall be reviewed at the beginning of the junior year and shall be granted only to those students who have:

1.-3. (No change.)

(b)-(f) (No change.)

(g) Students completing an approved program must be recommended for a [certificate] **Certificate of Eligibility with Advanced Standing** by their college or university **and must pass a State test pursuant to N.J.A.C. 6:11-5.1(a)3** before one will be issued by the State Board of Examiners.

(a)

**STATE BOARD OF EDUCATION**

**Certification of Bilingual and ESL Teachers**

**Reproposed Amendment: N.J.A.C. 6:11-4.3 and 6:11-8.2**

**Reproposed Repeals and New Rules: N.J.A.C. 6:11-8.4 and 8.5**

Authorized By: Saul Cooperman, Commissioner, Department of Education; Secretary, State Board of Education.

Authority: N.J.S.A. 18A:1-1, 18A:4-15, 18A:6-7, 18A:6-34, 18A:6-38 and 18A:26-10.

Proposal Number: PRN 1989-465.

Submit written comments by October 5, 1989 to:

Irene Nigro, Rules Analyst  
NJ Department of Education  
225 West State Street, CN 500  
Trenton, New Jersey 08625

The agency proposal follows:

**Summary**

Since the creation of the bilingual/bicultural and English as a Second Language (ESL) teaching endorsements, the majority of new teachers hired annually in those fields have been employed under emergency certification. It is not uncommon for such teachers to remain employed on an emergency basis for eight to 10 years, working without special supervision and without completing requirements.

The proposed amendments and new rules would resolve this problem by establishing a reasonable and logistically feasible set of minimum requirements for each endorsement and by replacing emergency certification with specially supervised training programs, to be completed in all instances within two years of initial employment.

This proposal supersedes and replaces the prior proposal of similar amendments that was published in the New Jersey Register on January 17, 1989 (see 21 N.J.R. 95(a)). These amendments and new rules are revisions of those formerly proposed, taking into account other policies on provisional certification that are under consideration of the State Board as well as public comments received in response to the January 17 publication.

**N.J.A.C. 6:11-4.3 Emergency certificate**

The amendment would eliminate the use of emergency certification in the fields of bilingual and ESL education.

**N.J.A.C. 6:11-8.2 Common requirements; all college teacher education programs and State-approved alternative programs**

The amendment would require approved college programs leading to the bilingual and ESL endorsements to provide instruction in certain specialized topics.

**N.J.A.C. 6:11-8.4 Teacher of bilingual/bicultural education**

The new rule would require all candidates for bilingual/bicultural certification to obtain the preparation required for certification in the academic subjects they will teach. The rule would allow bilingual candidates the option of meeting common professional course requirements through the Provisional Teacher Program (see rule proposal in this Register) while working in a regular or bilingual classroom appropriate to the certificate sought. Those who elect to do so while teaching in a bilingual class would, in addition to meeting the usual entry requirements of the Provisional Teacher Program, have to pass a test of basic English communication skills prior to employment.

For the standard bilingual/bicultural endorsement, all candidates would be required to pass the communication test and to complete six credits of specialized coursework related to the special supplementary subject matter that is, cultural studies) and instructional responsibilities of bilingual teachers. The proposed new rule would allow candidates to

complete such study in a college program prior to employment, or in conjunction with employment through 90 clock hours of district-based formal instruction.

In all cases, the new rule would charge local employers with responsibility for choosing candidates who possess foreign language proficiency appropriate to the students and programs in which he or she will teach. N.J.A.C. 6:11-8.5 Teacher of English as a Second Language

The proposed new rule would require all ESL certification candidates to complete a one year program of training, support and evaluation while serving under provisional certification. Prior to provisional employment, each candidate would be required to hold a bachelor's degree and pass a test of English communication skills. These prerequisites are intended to provide ESL teachers with the general and academic education that all teachers must receive, and to ensure that they possess sufficient knowledge of English vocabulary and grammar to instruct students.

For the standard certificate, the new rule would require candidates to complete a State-approved district training program, including special supervision and support, and 180 clock hours (12 credits) of instruction in specialized ESL topics. Graduates of college programs approved for the preparation of ESL teachers would complete these study requirements in college.

#### Social Impact

The proposed amendments and new rules concerning bilingual/ESL certification would increase the number of candidates by providing an additional route to certification and improve the quality of the pool of prospective teachers in the fields of bilingual and ESL education. They would ensure that all new teachers in these fields meet entry requirements before they are employed in the public schools. They would also ensure that all bilingual and ESL teachers complete their training for standard certification within two years of their employment. The amendments and new rules are expected to increase the supply of bilingual/ESL teacher candidates by creating an alternate route to certification thereby increasing the selectivity of local hiring decisions; increase diversity in the bilingual/ESL teacher candidate pool by opening the door of teaching to broader and more culturally diverse groups of candidates; and improve the quality of training of bilingual/ESL teachers by strengthening their basic and liberal education, their subject preparation and the practical aspects of their professional education.

#### Economic Impact

Costs of maintaining the proposed bilingual/ESL certification system will be paid through fees charged to certification candidates in the form of college tuition, and pursuant to N.J.A.C. 6:11-3.3(c) alternate route instructional fees, provisional support fees and general certification fees (\$40.00 per candidate). Other existing State-approved district training programs currently require candidates to pay a mentor fee of \$900 per year. Mentor fees associated with district training programs for Bilingual/ESL teachers may or may not be the same. There will be no significant cost to the public.

#### Regulatory Flexibility Statement

A Regulatory Flexibility Statement is not required because these amendments and new rules do not impose reporting, recordkeeping or other compliance requirements on small businesses. Amendments and new rules impact solely upon New Jersey School districts and on schools operated by the New Jersey Department of Education.

**Full text** of the proposal follows (additions shown in boldface **thus**; deletions in brackets [thus]).

#### 6:11-4.3 Emergency certificate

(a) An emergency certificate is a substandard one-year certificate issued only in the field of educational services, teacher of the handicapped, teacher of the blind and partially sighted, teacher of the deaf and hard of hearing[, bilingual education, English as a Second Language] and certain technical fields (see N.J.A.C. 6:11-8.3).

(b) (No change.)

#### 6:11-8.2 Common requirements; all college teacher education programs and State-approved alternative programs

(a) Approved college programs and [state] **State**-approved alternative-programs shall include study in the following areas of professional education:

1.-3. (No change.)

[4. Physiology and Hygiene: In accordance with the provisions of N.J.S.A. 18A:26-8, candidates must pass an examination in physiol-

ogy and hygiene, including the effects of narcotics and alcohol. In lieu of this examination, the applicant may present basic military training or study in areas such as biology, health or nutrition.]

**4. Bilingual/Bicultural Education: programs leading to the bilingual/bicultural endorsement shall provide approximately six credit hours of study in the following specialized topics: the historical and cultural backgrounds of limited English proficient students, the specialized instructional content of bilingual education, and techniques of teaching bilingual students.**

**5. English as a Second Language (ESL): programs leading to the English as a Second Language endorsement shall provide approximately 12 credit hours of study in the following specialized topics: the historical and cultural backgrounds of limited English proficient students, the specialized instructional content of ESL education, and techniques of teaching English as a second language.**

#### [6:11-8.4 Bilingual/bicultural education

(a) The bilingual/bicultural education endorsement requires prior completion of requirements for certification in another instructional field. Therefore, candidates will already have acquired essential knowledge and skills and shall not be required to complete student teaching or a State-approved alternative. Teachers in the field of bilingual/bicultural education may be hired on an emergency basis in accordance with N.J.A.C. 6:11-4.3. Applicants may obtain certificates by completing an approved college program or through a review of their college transcripts.

(b) The requirements are as follows:

1. A bachelor's degree based upon a four-year program in an accredited college;

2. A standard New Jersey teaching certificate in another field;

3. Completion of 30 semester-hour credits in bilingual/bicultural education, including study in the following areas.

i. Cultural and cross-cultural studies: A minimum of 12 semester-hour credits, in separate or integrated courses, including study in each of areas (1), (2) and (3) below is required, each course should be designed to increase the understanding of crosscultural variables affecting learning, and include such courses as the following:

(1) Social psychology and the bilingual child or Contemporary social problems (with emphasis on the bilingual/bicultural child); except

(A) An applicant who has completed a minimum of three full years of successful experience as a teacher of bilingual/bicultural and/or English as a second language education under a valid New Jersey standard or substandard certificate, or its equivalent, will be excused from completing three credits in this area;

(2) Language and culture; except an applicant who has completed a minimum of three full years of successful experience as a teacher of bilingual/bicultural and/or English as a second language education under a valid New Jersey standard or substandard certificate, or its equivalent, will be excused from completing credits in this area;

(3) Bilingual/bicultural field experiences, except an applicant who has completed a minimum of one full year of successful experience as a teacher of bilingual/bicultural and/or English as a second language education under a valid New Jersey standard or substandard certificate, or its equivalent, will be excused from completing three credits in this area, and an applicant who has completed three or more years of successful experience will be excused from completing an additional three credits in this area;

(4) Cultural anthropology;

(5) Comparative cultures.

ii. Linguistics: Three credits in the Area of study (1) below is required.

(1) Applied linguistics: Courses stressing techniques of second language skills development.

iii. Other areas: A minimum of nine semester-hour credits in separate or integrated courses. Areas of study (1), (2) and (3) below are required.

(1) Foundations of bilingual/multicultural education (rationale, history, survey of existing models);

(2) Theory and practice of teaching the bilingual child in content areas. If this requirement is fulfilled with coursework, then it should be taught in English and the other language being used as a medium

of instruction, wherever possible, except an applicant who has completed a minimum of three full years of successful experience as a teacher of bilingual/bicultural education under a valid New Jersey standard or substandard certificate, or its equivalent, will be excused from completing three credits in this area;

(3) Theory and practice of teaching English as a second language, except an applicant who has completed a minimum of three full years of successful experience as a teacher of English as a second language education under a valid New Jersey standard or substandard certificate, or its equivalent, will be excused from completing three credits in this area.

iv. Demonstration of verbal and written proficiency in English and in one other language used also as a medium of instruction.

(c) All bilingual/bicultural certification programs to be offered at New Jersey colleges and universities must be reviewed by the Department of Higher Education and approved by the State Department of Education. Bilingual/bicultural programs shall be developed by institutions of higher education so that the requirements set forth in subsection (b) above of this section may be met in a variety of settings, including but not limited to specific courses.

(d) The participants in such approved programs shall acquire the skills and knowledge prescribed in these rules and regulations before the dean of education recommends the candidate to the Bureau of Teacher Preparation and Certification for a bilingual/bicultural certificate.]

#### 6:11-8.4 Teacher of Bilingual/bicultural education

(a) Each candidate for the provisional certificate in the field of bilingual/bicultural education shall:

1. Possess or be eligible for a standard or provisional New Jersey instructional certificate appropriate to the subject or grade level to be taught;

2. Pass a State test of English communication skills; and

3. Obtain an offer of employment in a position that requires the endorsement, teacher of bilingual/bicultural education.

(b) Applicants who meet the requirements in (a)1 and 2 above shall be issued Certificates of Eligibility which will permit them to seek and accept employment in positions requiring certification as a teacher of bilingual/bicultural education.

(c) No person shall be employed under provisional certification for more than two years in a position requiring certification as a teacher of bilingual/bicultural education.

(d) Certificates of Eligibility with Advanced Standing shall be issued to all persons who have completed formal study and test requirements for bilingual certification pursuant to (e)2 and 3 below but who have never previously served a provisional year or completed a State-approved district training program for any certificate endorsement pursuant to N.J.A.C. 6:11-5.

(e) Each candidate for the standard certificate in the field of bilingual/bicultural education shall:

1. Possess a standard New Jersey instructional certificate appropriate to the subject or grade level to be taught;

2. Pass a State test of English communication skills; and

3. Complete at least six credit hours of college coursework or 90 clock hours of district-based formal training in the following topics: the historical and cultural backgrounds of limited English proficient students, the specialized instructional content of bilingual education, and techniques of teaching bilingual students. Those candidates who complete this requirement while serving as a provisionally certified bilingual education teacher shall be supervised by a support team pursuant to N.J.A.C. 6:11-5.

#### [6:11-8.5 Teaching English as a second language

(a) Teachers of English as a second language may be hired on an emergency basis in accordance with N.J.A.C. 6:11-4.3. Applicants may obtain certification by completing an approved college program or through a review of their college transcripts.

(b) The requirements are as follows:

1. A bachelor's degree based upon a four-year curriculum in an accredited college;

2. Successful completion of a college curriculum approved by the State Department of Education as a basis for issuing this certificate; or

3. Successful completion of a program of college studies including the following.

i. A minimum of 45 semester-hour credits in general background courses distributed in at least four of the following fields:

- (1) English;
- (2) Social studies;
- (3) Science;
- (4) Fine arts;
- (5) Mathematics;
- (6) Foreign languages;
- (7) Philosophy and psychology;
- (8) Music.

ii. Fifteen credits in the field of professional education in accordance with New Jersey certification standards;

iii. Thirty credits, comprehensive field endorsement:

(1) Cultural and cross-cultural studies: A minimum of nine semester-hour credits in separate or integrated courses, including study in each of areas (A), (B), (C) and (D) below is required—designed to increase the understanding of cross-culture variables affecting learning, including such courses as the following:

(A) Social psychology of the bilingual child; or

(B) Contemporary social problems (with emphasis on the bilingual/bicultural child), except an applicant who has completed a minimum of three full years of successful experience as a teacher of bilingual/bicultural and/or English as a second language education under a valid New Jersey standard or substandard certificate, or its equivalent, will be excused from completing three credits in this area;

(C) Language and culture;

(D) Bilingual/bicultural field experiences, except an applicant who has completed a minimum of one full year of successful experience as a teacher of bilingual/bicultural and/or English as a second language education under a valid New Jersey standard or substandard certificate, or its equivalent, will be excused from completing three credits in this area;

(E) Cultural anthropology;

(F) Comparative cultures.

(2) Linguistics: Twelve semester hours. Courses in areas (A), (B) and (C) below are required:

(A) General linguistics;

(B) Phonology and structure of American English;

(C) Applied linguistics (including problems of second language experience);

(D) Comparative linguistics;

(E) Semantics;

(F) Dialectology;

(G) Sociolinguistics;

(H) Psycholinguistics;

(I) Grammar systems;

(J) History and development of the English language, except an applicant who has completed a minimum of three full years of successful experience as a teacher of English as a second language under a valid New Jersey standard or substandard certificate, or its equivalent, will be excused from completing three credits in this area. "General linguistics," "Phonology and structure of American English," and "Applied linguistics" will not be excused.

(3) Theory and practice of teaching English as a second language: Six credits, except an applicant who has completed a minimum of three full years of successful experience as a teacher of English as a second language education under a valid New Jersey standard or substandard certificate, or its equivalent, will be excused from completing three credits in this area.

(4) Foreign language: Minimum of three credits, except applicants who have not completed coursework in a language foreign to their native tongue may be excused from completing this requirement if they have:

(A) Successfully completed a State Department of Education language proficiency interview; or

(B) Successfully completed a Thomas Edison College Examination Program (TECEP); or

(C) Successfully completed a College Level Examination Program (CLEP); or

(D) Presented official verification by a college or university that an applicant has fulfilled the requirement in a manner other than through the completion of a course; or

(E) Successfully completed any other oral language proficiency instrument approved by the State Board of Examiners.

(5) Evidence of native or near-native competency in English as determined by guidelines to be established by the State Department of Education.

iv. Approved student teaching in an English as a second language setting;

v. Physiology and hygiene.

(c) The holder of a standard New Jersey teacher's certificate may qualify for an endorsement to teach English as a second language by completing the 30-credit comprehensive field endorsement.

(d) All English as a second language certification programs to be offered at New Jersey colleges and universities must be reviewed by the Department of Higher Education and approved by the State Department of Education. English as a second language programs shall be developed by institutions of higher education so that the requirements set forth in (b) above may be met in a variety of settings, including but not limited to specific courses.

1. The participants in such approved programs shall acquire the skills and knowledge prescribed in these rules and regulations before the dean of education recommends the candidate to the Bureau of Teacher Preparation and Certification for an English as a second language certificate.]

#### **6:11-8.5 Teacher of English as a second language**

(a) Each candidate for the provisional certificate in the field of teaching English as a second language shall:

1. Hold a bachelor's degree from an accredited college or university;

2. Pass a State test of English communication skills; and

3. Obtain an offer of employment in a position that requires the endorsement, teacher of English as a second language.

(b) Applicants who meet the requirements in (a)1 and 2 above shall be issued Certificates of Eligibility which will permit them to seek and accept employment in positions requiring certification as a teacher of English as a second language.

(c) Certificates of Eligibility with Advanced Standing shall be issued to all persons who meet the test requirement pursuant to (a)2 above and who have completed a college program approved by the New Jersey Department of Education for the preparation of teachers of English as a second language.

(d) Each candidate for the standard certificate in the field of teaching English as a second language shall:

1. Possess a provisional certificate pursuant to (a)1.-3. above;

2. Pass a State test of basic communication skills;

3. Complete a State-approved district training program pursuant to N.J.A.C. 6:11-5; and

4. Complete twelve credits or 180 clock hours of formal instruction in the following topics: the historical and cultural backgrounds of limited English proficient students, the specialized instructional content of ESL education, and techniques of teaching English as a second language. This requirement shall not apply to candidates who are holders of Certificates of Eligibility with Advanced Standing pursuant to (c) above.

(e) Requirements (d)1 and 2 above shall not apply to persons who hold New Jersey instructional certificates in other teaching fields. However, such already-certified teachers may meet requirement (d)3 above working under provisional ESL certification under the supervision of a support team pursuant to N.J.A.C. 6:11-5.

(a)

## **STATE BOARD OF EDUCATION**

### **Pupil Transportation**

#### **Proposed Readoption with Amendments: N.J.A.C. 6:21**

Authorized By: Saul Cooperman, Commissioner, Department of Education; Secretary, State Board of Education.

Authority: N.J.S.A. 18A:1-1, 4-15, and 39-21.

Proposal Number: PRN 1989-445.

Submit written comments by October 5, 1989 to:

Irene Nigro, Rules Analyst  
State Department of Education  
225 West State Street, CN 500  
Trenton, New Jersey 08625

The agency proposal follows:

#### **Summary**

Pursuant to Executive Order No. 66(1978), N.J.A.C. 6:21, Pupil Transportation, expires on August 9, 1990.

These rules were originally promulgated and are being readopted with amendments to ensure the safe and efficient transportation of pupils in the state of New Jersey. The Department has been extensively reviewing the rules on pupil transportation since 1987. As part of this effort, a pupil transportation committee was established to review existing rules and propose needed amendments to both clarify and strengthen rules pertaining to pupil transportation. The committee was composed of transportation supervisors, school business officials, and Department staff.

Readoption with the following amendments is proposed. A revision of the current rules regarding contracts and bidding procedures to improve the governance and administration of pupil transportation at local, county and State levels is proposed. At this time, no changes are proposed to vehicle specifications listed in subchapters 5 and 8 and only minor changes are recommended to subchapter 9 due to the need for an extensive review of the National Minimum Standards for School Buses and the Department of Education standards. Recommendations for the comprehensive revision of these subchapters will be presented at a later date. Many filing instructions and actual forms which are not regulatory have been deleted throughout this chapter. These instructions will appear on specific forms and in the Policies and Procedures Manual for Pupil Transportation published by the New Jersey State Department of Education, Bureau of Pupil Transportation.

The proposal includes the following major recommendations:

N.J.A.C. 6:21-1, Standards, contains requirements for reporting school bus accidents, defines the term "remote from the schoolhouse" and establishes standards for retirement of schoolbuses. The amendments to this subchapter include the removal of language duplicated elsewhere in the rules and the incorporation of specific reference to authority. In N.J.A.C. 6:21-1.1, additional language was added to clarify that the requirements of this chapter apply to public school pupils and nonpublic school pupils receiving transportation services from a district board of education. A subsection was also added which describes the availability of pupil transportation forms. Procedures which are no longer required and instructions which are found directly on Department of Education forms were deleted. Clarifying language was added to N.J.A.C. 6:21-1.3 and 1.4.

N.J.A.C. 6:21-2, Requirements for Private School Transportation, establishes eligibility requirements of non-public school pupils for transportation services provided by a local board of education. The amendments to this subchapter serve to clarify requirements for private school transportation. New language was added in order to ensure the establishment of policies consistent with those governing public school transportation. Late registration procedures in N.J.A.C. 6:21-2.2(e) were moved to a more appropriate section of this chapter. Procedures requiring a letter from parents explaining the reason for late applications was deleted.

N.J.A.C. 6:21-3, Requirements of Public School Transportation, sets out the statutory basis for the transportation of public school pupils. This subchapter has been amended to ensure that all district boards of education adopt policies and procedures to govern the transportation of pupils to and from school and school related activities.

N.J.A.C. 6:21-4, School Bus Capacity, addresses overcrowding, standing and limits on capacity of vehicles when transporting pupils to and from school. This subchapter has been amended to remove unnecessary

language. Several sections have been condensed and one section has been repealed. The maximum seating capacity of 13 inches for each elementary school pupil, originally part of N.J.A.C. 6:21-4.3, has been eliminated. The maximum seating capacity of 15 inches is now consistent for high school and elementary pupils.

N.J.A.C. 6:21-5, Standards for School Buses, establishes school bus chassis and body standards to ensure the safety of pupils being transported. This subchapter will be revised later this year. No changes are proposed at this time.

N.J.A.C. 6:21-6 (Reserved)

N.J.A.C. 6:21-7, State Aid—This subchapter clarifies expenditures eligible for State transportation aid and allows all other transportation costs for educational purposes, excluding less than remote transportation, to be eligible for equalization aid. The language from N.J.A.C. 6:21-7.2 has been moved to N.J.A.C. 6:21-7.4. Procedures and obsolete language were deleted.

N.J.A.C. 6:21-8, Use of P.U.C. Vehicles as School Buses, identifies exemptions to school bus chassis and body specifications for vehicles under the jurisdiction of the Department of Transportation. This subchapter will be revised at a later date. No changes are proposed at this time.

N.J.A.C. 6:21-9, Small Vehicle Equipment Specification, defines "small vehicle" as it pertains to pupil transportation and establishes maximum capacity and safety equipment requirements. The subchapter has been revised to include nonsubstantive changes which serve to keep regulatory language uniform throughout the chapter. Additionally, the seating capacity has been revised to reflect the new standard established in subchapter 4.

N.J.A.C. 6:21-10, Small Vehicle Regulations, establishes registration requirements for small vehicles under contract with a district board of education. Amendments to this subchapter include nonsubstantive changes which serve to keep regulatory language uniform throughout the chapter. Additionally, the rule regarding requirements for a parent transporting his or her own child or children to and from school, which previously appeared in subchapter 11, has been included with clarifying language.

N.J.A.C. 6:21-11, Drivers, establishes minimum requirements for becoming a school bus driver. This subchapter has been repealed and replaced. Suggested procedures which are not regulatory have been deleted and will appear in the Policies and Procedures Manual for Pupil Transportation. A statement ensuring district compliance with the Division of Motor Vehicles and Department of Education rules has been included. Provision for use of safety belts was moved from N.J.A.C. 6:21-11.5 to 11.1.

N.J.A.C. 6:21-12, Advertising for Bids, set out a form recommended for use in advertising for bids. This subchapter has been repealed and reserved. The form previously contained in this subchapter will now appear as a sample form in the Policies and Procedures Manual for Pupil Transportation.

N.J.A.C. 6:21-13, Bid Specifications, defines what items are to be included in bid specifications by district boards of education. The subchapter was repealed and replaced with language retained from the original rule as well as amendments thereto. The definition of "route" was clarified and language added to more clearly specify items to be included in the specifications.

N.J.A.C. 6:21-14, Bond—This subchapter has been repealed and replaced, retaining some language. This subchapter defines the types of surety bonds that are acceptable. It also identifies acceptable bid guarantees and identifies the procedure for returning bid guarantees to unsuccessful bidders.

N.J.A.C. 6:21-15, Bidding, establishes bidding procedures and identifies bidding document requirements for district boards of education. This subchapter has been repealed and replaced. While some of the old language was retained, changes were made to this subchapter to clarify the district board of education's responsibility in the bidding procedure and to identify documents that are required as part of the bid. Forms were deleted. The bid form will appear as a sample form in the Policies and Procedures Manual for Pupil Transportation. The questionnaire form will be available through the county superintendent of schools and the Bureau of Pupil Transportation. Bulk/composition bids are also defined.

N.J.A.C. 6:21-16, Contracts—This subchapter establishes the documents required for the approval of transportation contracts by the county superintendent of schools. It clarifies the requirements for bidding and establishes types of contracts and related documents which include quoted

contracts, renewing contracts, addendum to contracts, transfers and joint transportation agreements.

N.J.A.C. 6:21-17, Insurance, establishes the minimum limits of liability insurance coverage to be carried by local boards of education and contractors transporting pupils. Amendments to this subchapter increase the minimum limit of liability insurance for bodily injury and property damage for vehicles transporting students from \$300/\$500,000 to \$1 million. Nonsubstantive changes were also made to clarify existing language and update language for consistency with the chapter.

N.J.A.C. 6:21-18, Inspection, establishes the requirement for a systematic inspection of school vehicles and identifies vehicles under the jurisdiction of the Division of Motor Vehicles and the Department of Transportation. A section was added to this subchapter which provides an exemption from authorization for school use on the certificate of inspection for vehicles under the jurisdiction of Department of Transportation when they are being used on a franchised route or chartered for extracurricular activities. No other changes are proposed to this section.

N.J.A.C. 6:21-19, Pupil Transportation Governance and Administration. A new rule has been added which clearly specifies the responsibility of the district board of education, county superintendent of schools, the Bureau of Pupil Transportation, the State Board of Education and the Commissioner with regard to pupil transportation.

#### Social Impact

The proposed re-adoption with amendments will have a positive social impact upon divisions of the Department, local school districts, contractors, parents and school bus drivers by providing greater clarification of operating procedures, fixed responsibilities and by removing any ambiguity as to what documents are required for the approval of contracts. The amendments pinpoint the responsibility of local districts and require the establishment of district policies and procedures which continue to ensure the safe and efficient transportation of pupils in the state of New Jersey. The rules provide contractors with specific information regarding contracting practices that enable them to conduct business more efficiently and allows for long range planning of services. Additionally, the re-adoption with amendments provides local districts with a clear understanding of transportation practices which will enable them to obtain State transportation aid.

#### Economic Impact

The proposed re-adoption with amendments will have a positive economic impact upon local districts by providing additional funds of approximately \$15 million in equalization aid which is the major funding category from State sources for local district expenditures. In addition, provided the requirements of N.J.A.C. 6:21 are met, 90 percent of approved transportation costs will be eligible for State transportation aid. The increased minimum limit of liability insurance coverage of \$1 million is readily available at an increased cost of approximately \$110 per year. This will impact slightly local districts and contractors. However, in some cases, districts and contractors already carry insurance coverage in excess of this requirement.

#### Regulatory Flexibility Analysis

Several new reporting, recordkeeping and compliance requirements will result from this proposal. All requirements effect only a small percentage of small businesses and their impact is minimal. There will be an additional cost of approximately \$110.00 per year to a small number of contractors because of the required increase in insurance coverage from \$300/\$500,000 to \$1 million. This change in requirement should have little impact upon small businesses since it represents what is currently in practice. Coverage of \$300/\$500,000 is outdated. Most contractors already carry insurance for \$1 million. The rules impose standards on contractors for submission of contracts, accident reports and related documents. This will not prove burdensome to small businesses in that the recordkeeping required falls within the scope of what is necessary to run a bus service company. The requirements are not extraordinary and contractors have easy access to the information sought by the Department. The Department continues to encourage fair, open and competitive bidding across the state of New Jersey.

The only types of small businesses these rules will affect are bus contractors in New Jersey with less than one hundred employees. This includes most, if not all, of the contractors in the State. The only professional service a contractor might choose to employ as a result of these rules is the hiring of an attorney to review contracts. This is an option only. In the opinion of the Department, all contracts and related documentation are in "layman's" terms so it is not a necessity. This option therefore would have only minimal impact upon those few con-

tractors that choose to use it. There are no initial capital costs aside from the increase in the insurance premium which was already noted in this analysis.

Due to the fact that these rules require only minimal changes in recording, recordkeeping and compliance requirements for contractors, no adverse economic impact on small businesses is anticipated.

Full text of the proposed readoption and repeals may be found in the New Jersey Administrative Code at N.J.A.C. 6:21.

Full text of the proposed amendments and new rules follows.

## SUBCHAPTER 1. [STANDARDS] GENERAL PROVISIONS

### 6:21-1.1[Rules] General requirements

(a) Under the provisions of the New Jersey Statutes, the State Board of Education shall adopt and enforce rules consistent with law to cover the design and operation of all [public] school buses used in the transportation of **public school pupils to and from school and school related activities including the transportation of nonpublic school pupils by a district board of education.**

(b) **Transportation of pupils attending public or nonpublic schools shall be provided pursuant to N.J.S.A. 18A:39-1 et seq.** [The first standards adopted by the State Board of Education were published in 1932 and revised in 1935, 1937, 1939, 1948, 1953, 1959, 1962 and 1967. This edition is revised in keeping with New Jersey law in an effort to provide standards to insure adequate and safe pupil transportation.]

(c) The rules as herein prescribed and adopted by the State Board of Education are effective as of September 1, 1985.

(d) Specifications for school buses and rules for transportation of public school pupils adopted by the State Board of Education, except as hereinafter provided, shall apply to all buses operated under contracts with district boards of education and to all district-owned buses.]

(e) **All forms prescribed by the Commissioner of Education referred to in this chapter are available in the office of the county superintendent of schools, and at the Bureau of Pupil Transportation, Department of Education, 225 West State Street, CN 500, Trenton, New Jersey 08625.**

(f) **It is recommended that district boards of education and school bus contractors acquaint themselves with the procedures described in the Department of Education Policies and Procedures Manual for Pupil Transportation to ensure efficiency in the implementation of a pupil transportation program. This manual is available for review at the transportation office of the district board of education, the office of the county superintendent and the Bureau of Pupil Transportation.**

### 6:21-1.2 Accident reporting

(a) Every school bus driver [must] **shall** immediately inform the principal of the receiving school following an accident which involves an injury, death or property damage. [He or she must] **The driver shall also complete and file the Preliminary School Bus Accident Report prescribed by the Commissioner of Education.** [accident report in quadruplicate and deliver it by the conclusion of the next working day to the principal of the receiving school. The principal shall retain one copy (white) and shall forthwith transmit one copy (blue) to the district board of education providing the transportation, one copy (yellow) to the county superintendent of schools and one copy (pink) to the State Department of Education, 225 West State Street, CN 500, Trenton, New Jersey 08625. The necessary forms are available at the office of the school principal or the county superintendent of schools.]

(b) [In addition to the above, the] **The driver of a school bus involved in an accident resulting in injury or death of any person, or damage to property of any one person in excess of \$500.00 shall within 10 days after such accident complete and file a Motor Vehicle Accident Report in accordance with N.J.S.A. 39:4-130.** [forward a written report of the accident to the Bureau of Security Responsibility, Division of Motor Vehicles, 25 South Montgomery Street, Trenton, New Jersey 08625.]

(c) Each district board of education shall establish **policies and procedures to be followed by the school bus driver in the event of**

an emergency [involving to and from school transportation and all extracurricular trips].

### 6:21-1.3 Remote defined

(a) The words "remote from the schoolhouse" shall mean beyond 2½ miles for high school pupils (grades 9 through 12) and beyond two miles for elementary pupils (grades kindergarten through eight), except for [pupils suffering from physical or organic defects] **educationally handicapped pupils.** [State aid for shorter distances for the sole reasons of traffic hazards should not be given, inasmuch as traffic hazards are a local responsibility.]

(b) For the purpose of determining remoteness in connection with pupil transportation, measurement shall be made by the shortest route along public roadways or **public walkways** from the entrance of the pupil's residence nearest such public roadway or **public walkway** to the nearest public entrance of the assigned school.

### 6:21-1.4 Retirement of school buses

(a) School buses [(Type I)] manufactured prior to April 1, 1977, other than those of the transit type whose gross vehicle weight (G.V.W.) exceeds 25,000 pounds, shall not be used for pupil transportation [purposes beyond the end of the 10th year from the date of manufacture, as noted on the vehicle registration or the end of the school year in which that date falls, whichever is later].

(b) School buses, **Type I and Type II**, as defined by [the Code of Federal Regulations (49 CFR 571.3) and] **N.J.S.A. 39:1-1, which are registered and inspected in this State**, manufactured on or after April 1, 1977, other than those of the transit type whose gross vehicle weight (G.V.W.) exceeds 25,000 pounds, shall not be utilized for pupil transportation purposes beyond the end of the [12th] **twelfth** year from the [date] year of manufacture, as noted on the vehicle registration, or at the end of the school year in which that [date] year falls, whichever is later. Such buses, when used beyond the [10th] **tenth** year, shall have an annual in-depth inspection by the Division of Motor Vehicles prior to the [beginning of the] **ensuing** school year.

(c) School buses of transit type whose gross vehicle weight (G.V.W.) exceeds 25,000 pounds shall not be used for pupil transportation purposes beyond the end of the [20th] **twentieth** year from the [date] year of manufacture, as noted on the vehicle registration, or at the end of the school year in which that [date] year falls, whichever is later.

## SUBCHAPTER 2. REQUIREMENTS FOR [PRIVATE] NONPUBLIC SCHOOL TRANSPORTATION

### [6:21-2.1 Existing rules

All existing rules adopted by the State Board of Education to cover the design and operation of school buses used in the transportation of pupils to and from a public school shall be applicable to the transportation of pupils to and from a nonprofit private school.]

### 6:21-2.1 General requirements

(a) **Transportation or aid in lieu of transportation shall be provided in accordance with N.J.S.A. 18A:39-1 et seq.**

(b) **District boards of education shall adopt policies and procedures governing the transportation of pupils to and from school.**

(c) **Aid in lieu of transportation shall be provided once a district board of education has publicly advertised for bid and has made the determination that the cost per pupil will exceed the maximum allowable rate as established by N.J.S.A. 18A:39-1.**

### 6:21-2.2 Registration procedure

(a) **The private school shall obtain the Application for Private School Transportation, as prescribed by the Commissioner of Education, from the public schools.**

[(a)] (b) It shall be obligation of the parent or guardian of private school pupils to [secure] **annually obtain the Application For Private School Transportation, as prescribed by the Commissioner of Education, [pupil transportation forms (B6T)] from the administrative office of the private school in which the pupil is ["enrolled"]**.

[(b)] (c) Upon completion by the parent or guardian, the [form] **application** shall be returned to the private school on or before May

1 preceding the school year in which transportation is being requested.

[(c)] (d) The private school shall [forward] annually collect from the parent or guardian the applications [forms] and submit them to the public school from which transportation is being requested for registration and implementation prior to May 15.

[(d)] (e) The public school shall notify the parent or guardian and private school as to the determination of each application by August 1.

[(e) Late registration rules are:

1. A late application shall be any application received by a private school after May 1.

2. Parents or guardian of private school pupils shall secure pupil transportation application forms (B6T) from the administrative office of the private school in which the pupil is "enrolled".

3. Parent or guardian shall return application to the private school with statement of reason for late application. Application shall be noted by the private school and then forwarded together with the reason for lateness to the public school for registration and implementation.

4. Public school shall note information on the summary form (B8T).

5. The public school shall notify the parent or guardian and the private school as to the determination of the application within 15 days of receipt from the private school or August 1, whichever is later.]

(f) A late application shall be any application received by the district after May 15. Eligible pupils will receive transportation or aid in lieu of transportation based upon the date of receipt of the application by the public school.

(g) Prior to August 1, the public schools shall prepare the Private School Transportation Summary form as prescribed by the Commissioner of Education.

#### 6:21-2.4 Grade level

[Transportation] Students eligible for transportation or aid in lieu of transportation shall be [limited to children] enrolled in grades kindergarten through grade 12. The determination of entrance age for pupils shall be in accordance with N.J.S.A. 18A:38-5 and 18A:44-2.

#### 6:21-[2.4]2.5 School closings [due to weather or other condition]

Suspension of the operation of the pupil transportation system, [when] due to inclement weather or[,] other conditions [indicate the necessity therefor,] shall be the responsibility of the public school authorities providing the transportation.

#### [6:21-2.6 Registration procedure

(a) The private school shall secure the necessary application form (B6T) from the public schools.

(b) Private schools shall annually collect from the parent or guardian, alphabetize and submit the application form (B6T) by May 15 to the district from which transportation is being requested.

(c) Prior to August 1, the public schools shall prepare and forward the white and pink copy of the summary form (B8T) to the private school with columns a, b, c, d, e, f, and g completed. In column "g", use this code: U.M.-under mileage; O.M.-over mileage; N.T.-no transportation; and P.S.-profit school.

(d) Simultaneously with subsection (c) of this Section, the public school shall notify parents as to the decision regarding transportation.]

#### 6:21-2.6 Early withdrawal

The public school shall be immediately notified by the administrative agent of the private school when a pupil eligible for transportation or aid in lieu of transportation withdraws from the private school.

#### [6:21-2.7 Early withdrawal

When a transported or transportation aid pupil withdraws from the private school, immediate written notification by the administrative agent of the private school shall be made to the public school and date noted on the summary form (B8T).]

#### 6:21-2.7 Certification of attendance

(a) Between January 1 and January 10 of each year, the private school administrator shall certify on forms prescribed by the Commissioner of Education, that the named pupils were enrolled for the first half of the academic year (September to January) and return the forms to the public school prior to January 15.

(b) The public school shall evaluate the January certification report and, if approved, shall pay aid in lieu of transportation to the parent or guardian of the eligible pupils after receiving a signed Request For Payment of Transportation Aid voucher as prescribed by the Commissioner of Education.

(c) Between May 1 and May 10 of each year, the private school administrator shall certify on forms prescribed by the Commissioner of Education that the named pupils were enrolled for the second half of the academic year, (January to June) and return the forms to the public school prior to May 15.

(d) The public school shall evaluate the May certification, and if approved, shall pay aid in lieu of transportation to the parent or guardian of the eligible pupils after receiving a signed Request For Payment of Transportation Aid voucher as prescribed by the Commissioner of Education.

(e) The district board of education shall send to the county superintendent of schools the Private School Transportation Summary form no later than August 1, following the close of the school year.

#### [6:21-2.8 Certification

(a) January procedure is:

1. Between January 1 and January 10 of each year, the private school shall certify, by an "x" mark in column (h) on both copies of the summary forms (B8T), that the named pupils were enrolled for the first half of the academic year (September to January).

2. Transported pupils or pupils whose parents or guardian received transportation aid, in lieu of transportation, must be noted as to enrollment for the semester. In case of late registration or early withdrawal, the exact number of days of enrollment must be noted in column (h). Payment shall be authorized according to N.J.S.A.

3. Upon completing certification, the white form shall be signed by the administrative office of the private school and returned to the public school prior to January 15.

4. The public school shall evaluate the report and, if approved, shall pay transportation aid to the parent or guardian of the eligible pupils.

5. The public school shall retain the white summary form (B8T) with noted certification and forward the yellow summary form (B8T) to the private school.

(b) May procedure is:

1. Between May 1 and May 10, the private school shall certify in column (i), on the yellow summary form (B8T), by an "x" mark that the pupils were enrolled for the second half of the academic year, January to June.

2. Transported pupils or pupils whose parents or guardian receive transportation aid, in lieu of transportation, must be noted as to enrollment for the semester. In case of late registration or early withdrawal, the exact number of days of enrollment must be noted in column (i). Payment shall be authorized according to statute law.

3. After certification, the yellow summary form (B8T), shall be signed by the administrative officer of the private school and returned to the public school prior to May 10.

4. The public school shall evaluate the yellow summary form (B8T), and if approved, shall pay transportation aid to the parent or guardian of the eligible pupils.]

#### [6:21-2.9 No bid procedure

If no bids are received after advertisement according to law, and the local board of education is convinced that the cost would exceed the statutory limitation of \$200.00 the local board of education may provide the parent with transportation aid pursuant to N.J.S.A. 18A:39-1.]

**SUBCHAPTER 3. REQUIREMENTS FOR PUBLIC SCHOOL TRANSPORTATION**

**6:21-3.1 Statutory basis**

(a) Transportation of pupils attending public schools [is] shall be furnished pursuant to N.J.S.A. 18A:39-1 et seq.

(b) District boards of education shall adopt policies and procedures governing the transportation of pupils to and from school and school related activities.

**SUBCHAPTER 4. SCHOOL BUS CAPACITY**

**[6:21-4.1 Overcrowding**

School buses shall not be overcrowded.]

**[6:21-4.2 Standees**

No standees shall be allowed.]

**[6:21-4.3 Determination of capacity**

In determining the maximum seating capacity of a bus, 15 inches of seat length shall be allowed for each high school pupil and 13 inches for each elementary school pupil.]

**6:21-4.1 Capacity**

(a) The number of pupils assigned to a seat may not exceed the gross seating length in inches divided by 15. Application of the foregoing formula shall not result in the approval of a school vehicle with a seating capacity in excess of 54.

1. Vehicles manufactured as 58 passenger elementary school vehicles owned by a district board of education or contractor prior to the effective date of this rule may be utilized until retirement.

(b) There shall be no standees.

(c) This section shall not apply to a bus while being used as a common carrier on a preset franchised route and schedule.

**[6:21-4.4 Limitations**

(a) No school bus with a capacity of more than 54 high school pupils or 58 elementary school pupils shall be approved for the transportation of school children.

(b) This Section shall not apply to a bus while being used as a common carrier. A public utility bus of larger capacity may be used under contract as a school bus, but may not transport more than 54 high school pupils or 58 elementary school pupils.]

**6:21-[4.5]4.2 Passengers**

[No passengers except] A district board of education shall insure that only enrolled eligible public school pupils, eligible private school pupils, adults serving as chaperons or authorized school personnel shall be [carried on scheduled trips] transported.

**SUBCHAPTER 7. STATE AID**

**[6:21-7.2 Sale of school vehicle**

(a) Any amount realized by a school district from the sale of a district owned vehicle, for which State funds have been or shall hereafter be apportioned for such vehicle, shall be deducted on a prorated basis as established by the initial purchase.

(b) Such amount shall be deducted from the next ensuing application for State aid for transportation by such district.

(c) The sale of any such bus shall be approved by the county superintendent of schools.]

**6:21-7.2 State aid**

Each district board of education shall be paid State aid for costs directly related to the transportation of pupils to and from school when the necessity, cost, and method have been approved by the county superintendent of schools pursuant to N.J.S.A. 18A:58-7. All other transportation costs for educational purposes, excluding less than remote transportation, shall be eligible for equalization aid and shall be included in the net current expense budget.

**[6:21-7.3 State aid approval**

(a) State aid for each approved transportation route should be 75 per cent of the adjusted cost of the route as follows:

$$\text{Cost of route X } \frac{\text{aided pupil miles from school}}{\text{Total pupil miles from school}} \text{ X } \frac{3}{4} = \text{State aid}$$

(b) Definitions pertaining to State aid approval include the following:

"Aided pupil" means a pupil whose transportation is acceptable for State aid (N.J.S.A. 18A:39-1, 18A:58-7, 18A:46-23).

"Nonaided pupil" means a pupil whose transportation is not acceptable for State aid.

For the purpose of State reimbursement, "miles from school" shall be the shortest distance in miles and tenths from the pupil's home to his assigned school by an accessible public roadway or walkway.

(c) Transportation routes should be arranged so that the buses will traverse the highways which serve the largest number of pupils within a reasonable time limit and at a minimum cost. Subject to exceptions, such as pupils suffering from physical and organic defects, buses should not be required to leave the main route to pick up elementary pupils residing within 1½ miles of the route and high school pupils residing within two miles of the route.

(d) State aided transportation should be limited to a trip to school in the morning and a trip from school following the afternoon session except as hereinafter provided:

1. Pupils attending double sessions because of insufficient facilities to accommodate them for a full day. The county superintendent in this case should approve State aid on a year-to-year basis if he is satisfied that the board of education, or the legal voters, as the case may be, are making a reasonable effort to eliminate part-time schooling.

(e) Attendants assigned to school vehicles by the board of education for the health, safety and welfare of the students may be State-aided, when in the opinion of the county superintendent of schools, such personnel is necessary.

(f) The following are examples where the county superintendent should not apportion State aid:

1. Trips to museums, art galleries, music festivals, athletic events, play days and so forth;
2. Special trips to transport pupils home who may have become ill during the school day;
3. Special trips for pupils being detained or voluntarily remaining beyond the normal school day;
4. Shuttle trips from the pupil's assigned school to another school or center for special instruction such as industrial arts, home economics, electronics, and so forth.
5. Exceptions include:

i. State aid may be approved under certain circumstances for transporting handicapped children from a public school to a center operated by a board of education for special services or instruction. The county superintendent should consult a representative of the State Department Office of Special Education to assure himself that:

- (1) This special service is needed;
- (2) This is the most satisfactory and economical means of providing the special service; and
- (3) State aid is not being used to encourage the continuation of an inadequate type of service or instruction.

ii. State aid may be approved under certain circumstances for transporting vocational students from a public school to a center operated by a local board of education or a county vocational board of education for vocational instruction. The county superintendent should consult a representative of the State Department Vocational Division to assure himself that the program is approved by the Vocational Division, and State aid is not being used to encourage the continuation of an inadequate type of service or instruction. To qualify for State aid such transportation should be provided by the resident district to pupils who spend at least one-half of their school day at the vocational center, and should be limited to one trip per school day from the resident high school to the vocational center and return.]

**6:21-7.3 State aid approval—route/contract**

(a) State aid for approved transportation routes shall be 90 percent of the approved cost of the route.

(b) For the purpose of State aid reimbursement, the words "remote from the school house" shall mean beyond 2½ miles for high school pupils (grades nine through 12) and, beyond two miles for elementary pupils (grades kindergarten through eight), except for educationally

handicapped pupils. The "miles from home to school" shall be the shortest distance in miles and tenths from the entrance of the pupil's home to the nearest public entrance of the assigned school by a public roadway or public walkway.

(c) State aid for transportation shall be limited to an approved regularly scheduled trip to school and a trip from school immediately following regularly scheduled sessions.

(d) State aid shall be approved for transporting handicapped children from a public school to an approved school or a center for special services or instruction.

(e) State aid shall be approved for transporting vocational students from a public school to a county vocational school for vocational instruction provided the students spend at least one-half of the school day at the vocational center.

#### 6:21-7.4 State aid approval—vehicles

(a) State aid shall be approved for the purchase, lease and rental of vehicles used for the transportation of pupils to and from school. The district board of education shall request the prior approval of the county superintendent for the sale and/or purchase of vehicles on the form prescribed by the Commissioner of Education.

(b) School vehicles shall be sold pursuant to N.J.S.A. 18A:18A-45. Any amount realized by a school district from the sale of a district owned vehicle for which State funds have been or shall hereafter be apportioned for such vehicle, shall be deducted on a prorated basis as established by the initial purchase. Such amount shall be deducted from the next ensuing application for State aid.

#### 6:21-7.5 State aid approval—salaries

(a) Salaries of the following district transportation personnel shall be approved for State aid when the following criteria are met.

1. **Supervisor**—The position of supervisor requires the prior approval of the county superintendent of schools. It shall be a full-time position with a minimum of 35 working hours per week, 12 months a year in districts providing transportation to and from school for a minimum of 1,000 pupils.

2. **Assistant Supervisor**—The position of assistant supervisor requires the prior approval of the county superintendent of schools. It shall be a full-time position with a minimum of 35 working hours per week, 12 months a year in districts which have an approved full-time supervisor and transport a minimum of 5,000 pupils to and from school.

3. **Secretary**—The position of secretary shall be a full-time position with a minimum of 35 hours per week, 12 months a year in districts which have an approved full-time supervisor and transport a minimum of 5,000 pupils to and from school.

4. **Clerk Typist**—The position of clerk typist shall be a full-time position with a minimum of 35 hours per week, 12 months a year in districts which have an approved full-time supervisor and transport a minimum of 5,000 pupils to and from school.

5. **First Mechanic**—The position of first mechanic shall be a full-time position with a minimum of 35 hours per week, 12 months a year in districts owning a minimum of 10 vehicles used for the transportation of pupils.

6. **Second Mechanic**—The position of second mechanic requires that a district own a minimum of 25 vehicles used for the transportation of pupils.

7. **Helper**—The position of helper requires that a district own a minimum of 15 vehicles used for the transportation of pupils.

8. **Additional personnel** for the maintenance of pupil transportation vehicles require the approval of the county superintendent of schools and the Bureau of Pupil Transportation.

9. A school bus/vehicle driver must meet all the requirements of this chapter.

10. **Attendant/Aide**—An attendant/aide is assigned to a school vehicle by the district board of education for the health, safety and welfare of handicapped students. This position requires the prior approval of the county superintendent of schools.

#### 6:21-7.6 State aid approval—other eligible items

(a) In order to be eligible for State transportation aid, the following items shall be directly related to the transportation of pupils to and from school and are subject to documented justifications:

1. Fuel, oil, lubricants, repair parts, tires, and tubes;

2. Rent/lease and utilities (if metered/billed separately and used exclusively for pupil transportation operation) of a transportation garage. District must own a minimum of 10 vehicles used for the transportation of pupils;

3. School bus/vehicle insurance;

4. Only original purchase of approved pupil transportation routing, scheduling and vehicle maintenance computer software programs and the maintenance of these approved computer software programs;

5. Printing and mailing costs related to pupil transportation;

6. School bus/vehicle driver's physical examination;

7. School bus/vehicle driver's fingerprints;

8. District map for routing and scheduling;

9. Advertising related to transportation;

10. First aid supplies and emergency equipment mandated on transportation vehicles;

11. Tolls paid for to and from school transportation;

12. Two-way radios and cellular phones. Purchases require the prior approval of the county superintendent of schools;

13. Cost related to emergency exit drills;

14. Safety equipment: top arms, roof hatches, crossing gates;

15. Special education travel expense in conjunction with out-of-district placements for educational reasons pursuant to N.J.A.C. 6:28-3.8(a)5; and

16. Seat belts/child restraint systems as mandated for special needs students.

### SUBCHAPTER 9. SMALL VEHICLE AND EQUIPMENT SPECIFICATIONS

#### 6:21-9.2 Capacity

(a) The number of pupils allowed in each vehicle shall be determined by the seat measurement. [15] Fifteen inches of seat length shall be allowed for each [high school (9-12) pupil and 13 inches for each elementary (K-8)] pupil.

(b) There shall be no standees.

#### 6:21-9.3 Chains or snow tires

Chains or snow tires [as required by the county superintendent of schools] shall be provided and must be used for safe operation in areas of snow and/or ice.

#### 6:21-9.5 First aid kit

(a) A first aid kit which is a dust proof metal unit without a lock, with the words FIRST AID printed on the cover [and with the contents to be maintained as hereinafter provided] must be provided with the contents maintained as follows:

- 1.-8. (No change.)

### SUBCHAPTER 10. SMALL VEHICLE REGULATIONS

#### 6:21-10.1 Motor Vehicle Registration

(a) The owner of a private small vehicle wishing to enter into a contract with a district board of education for the purpose of transporting pupils, to and from school and to and from related school activities, [must] shall register [his or her] the vehicle with the Division of Motor Vehicles. The Division of Motor Vehicles will recall the present passenger plates of the owner and issue school vehicle type 2 license plates at the prescribed registration fee. Owners of private small vehicles [must] shall renew the vehicle registration on an annual basis.

(b) A district board of education wishing to transport pupils in a district-owned vehicle to and from school and to and from related school activities [must] shall register the vehicle with the Division of Motor Vehicles. The Division of Motor Vehicles will provide the district board of education with school vehicle type 2 license plates at no registration fee. All no fee registration transactions with district boards of education will be valid for 36 months.

(c) (No change.)

#### 6:21-10.3 Parent transporting his or her own child or children

(a) A parent transporting only his or her own child or children under contract with a district board of education will not be required to possess a bus driver's license or to comply with the health examination prescribed for employees of the district board of education.

(b) Parents under contract with the district board of education utilizing a vehicle which has a capacity of greater than six shall be required to possess a bus driver's license in accordance with the Division of Motor Vehicles statute N.J.S.A. 39:3-10.1.

**SUBCHAPTER 11. DRIVERS**

**6:21-11.1 Requirements for drivers of school buses**

(a) Drivers of school buses/vehicles shall meet all requirements of N.J.S.A. 18A:39-17, 18, 19 and 20 and of the New Jersey Division of Motor Vehicles as per N.J.S.A. 39:1-1 et seq.

(b) Drivers of school vehicles equipped with lap belts shall be required to wear them whenever the vehicle is in motion.

**6:21-11.2 Driver procedure**

The driver shall complete daily a driver's school bus condition report as prescribed by the Commissioner of Education.

**6:21-11.3 Emergency exit drills from school buses**

(a) Schools shall organize and conduct emergency exit drills at least twice within the school year for all pupils who ride school buses.

(b) The school bus driver shall participate.

(c) Drills shall be conducted on school property and be supervised by the principal or person assigned to act in a supervisory capacity.

**SUBCHAPTER 12. [ADVERTISING FOR BIDS] (Reserved)**

**6:21-12.1 Recommended form**

The recommended form for advertising for bids is as follows:

Sealed proposals for the transportation of pupils will be received by the Board of Education at the School District of the Borough/Township of \_\_\_\_\_ at \_\_\_\_\_ P.M. (Eastern Standard Time) on \_\_\_\_\_ the \_\_\_\_\_ day of \_\_\_\_\_ 19\_\_\_\_ at \_\_\_\_\_ school building. Specifications and bid forms for the routes and a standard form of questionnaire to be answered by the bidder may be secured from \_\_\_\_\_. The Board of Education reserves the right to reject any and all bids.

\_\_\_\_\_  
Secretary  
\_\_\_\_\_  
Address]

**SUBCHAPTER 13. BID SPECIFICATIONS**

**6:21-13.1. General requirements**

(a) The district board of education shall designate a committee, official or employee to prepare the specifications for each route or contract for which proposals are sought. A copy of the specifications shall be submitted to the county superintendent prior to advertisement for bids. The specifications and advertisement for bids shall be approved and authorized by formal action of the board.

(b) Any specification drawn for purposes of competitive bidding shall be drafted in a manner designed to encourage free, open and competitive bidding. Specifications shall not knowingly exclude prospective bidders by reason of the impossibility of performance or bidding by any one bidder. Any contract drawn which fails to meet the requirements of this subchapter shall be set aside by the district board of education.

(c) Potential or successful bidders shall not draft specifications or route descriptions.

(d) Specifications shall not discriminate on the basis of race, religion, sex or national origin. Bidders shall have an approved affirmative action plan as required by P.L. 1975, c. 127 (N.J.S.A. 10:5-31 et seq.).

**6:21-13.2 Prescribed transportation specifications**

(a) Transportation specifications shall be prepared to include, but not be limited to, the requirements of this chapter.

(b) A separate route description shall be prepared for each individual route.

(c) A route is a selected or an established course of travel by a vehicle with definite stops for the purpose of loading and unloading students. Transportation routes should be arranged so that the buses will transverse the highways which serve the largest number of pupils within a reasonable time limit and at a minimum cost. Subject to exceptions,

such as educationally handicapped pupils, buses are not required to leave the main route to pick up elementary pupils residing within 1½ miles of the route and high school pupils residing within two miles of the route. The board of education shall reserve the right, with the approval of the county superintendent, to change the route. If any change of route results, adjustment in the contract price shall be made in accordance with the bid. The basis for any adjustment will be the separate and distinct per mile, per vehicle or per pupil increase/decrease cost included in the bid.

(d) A route for the transportation of regular public and nonpublic school pupils shall be described from the first bus stop to the destination listing each street traveled. The schedule for arriving and departing and the vehicle capacity shall also be included.

(e) A route for the transportation of special education pupils shall be described listing each bus stop, the schedule for arriving and departing and the vehicle capacity. The statement "the direction of the vehicle from the last stop shall be along the safest most direct route to the destination" shall be included.

(f) The need for specialized equipment, restrictions due to student classification or the need for an attendant shall be described.

(g) The specifications shall include a copy of the school calendar, provisions for emergency closings and conditions for cancellation of contracts.

(h) All equipment shall meet the current specifications for transportation as set forth in the rules of the State Board of Education and any additional specifications of the district board of education.

(i) All contractors shall comply with current applicable New Jersey statutes, regulations and with the policies and procedures of the district board of education governing pupil transportation.

(j) Specifications shall include the limits of liability insurance and the type(s) of bonding required by the district board of education.

(k) The bid specifications shall include a statement which clearly prohibits the commingling of students unless authorized to do so by the district board of education through the joint transportation agreement process.

**SUBCHAPTER 14. BOND**

**6:21-14.1 Bidder guarantee**

(a) A bidder shall be required to submit a guarantee payable to the district board of education that if a contract is awarded, the successful bidder will enter into a contract and will furnish a performance bond. Cash or negotiable securities are not authorized.

(b) The district board of education, at its discretion, shall specify the type guarantee required: certified check, cashier's check or bid bond.

(c) The district board of education shall require every bidder to complete a questionnaire form as prescribed by the Commissioner of Education.

(d) The amount to be deposited shall be five percent of the bid, but in no case may the certified check, cashier's check or bid bond exceed \$20,000.

(e) The bid bond, cashier's or certified check shall be forfeited upon refusal of the successful bidder to execute a contract; otherwise, guarantee shall be returned when the contract is executed and a surety bond filed.

(f) An unsuccessful bidder guarantee shall be returned within 10 days after the opening of the bids (Saturdays, Sundays and holidays excepted).

**6:21-14.2 Surety bonds**

(a) A surety bond shall be provided for the faithful performance of all provisions of the specifications and for all matters which may be contained in the notice to bidders relating to the performance of the contract.

(b) The district board of education, at its discretion, may require one type of surety bond or allow for either a corporate surety bond or personal surety bond.

(c) The questionnaire form prescribed by the Commissioner of Education shall be made part of the bidding documents furnished to potential bidders.

**6:21-14.3 Corporate surety bond**

(a) The district board of education may, at its discretion, require a surety bond furnished by a corporate surety company recognized by the State Department of Insurance as being authorized to do business in the State of New Jersey.

(b) Contracts and renewals shall be accompanied by a corporate surety bond for the total annual amount of the contracts. Bonding for multi-year contracts may be for such amount in excess of the proportionate annual amount as the district board of education shall determine. Contracts awarded on a per diem basis shall be bonded in the per annum amount based on 180 days.

(c) If it shall be necessary to substitute a corporate surety, the contractor shall furnish promptly the same information for the new corporate surety as required for the original corporate surety on the prescribed questionnaire form accompanying the bid.

**6:21-14.4 Personal surety bond**

(a) The district board of education, at its discretion, may permit a personal surety bond.

(b) Contracts and renewals shall be accompanied by a personal surety bond for the total annual amount of the contracts. Bonding for multi-year contracts may be for such amount in excess of the proportionate annual amount as the district board of education shall determine. Contracts awarded on a per diem basis shall be bonded in the per annum amount based on 180 days.

(c) Personal bonds shall be signed by at least two responsible sureties, who are residents of New Jersey, neither of whom shall be a member of the district board of education.

(d) If it shall be necessary to substitute a bondsman, the contractor shall promptly furnish the same information for the new bondsman as required for the original bondsman on the prescribed questionnaire form accompanying the bid.

(e) The district board of education shall have the right to reject an individual surety offer, and may find it beneficial to request a certification that the individual's net worth is sufficient to cover the bond.

(f) Personal surety bonds shall be submitted on the Personal Surety Bond for Pupil Transportation Contract form as prescribed by the Commissioner.

**SUBCHAPTER 15. BIDDING****6:21-15.1 Responsibility of district board of education**

(a) District boards of education shall have the option of annually bidding all transportation contracts or awarding annual extensions of an original contract. However, no contract for the transportation of pupils to and from school shall be made, when the amount to be paid during the school year for such transportation shall exceed the bid threshold limit and have the approval of the county superintendent of schools, unless the district board of education making such contract shall have first publicly advertised for bids. Such advertisement shall be published once in a newspaper circulating in the district at least 10 days prior to the date fixed for receiving proposals for such transportation. All bids shall be advertised with the time and place fixed to each advertisement for submission of proposals to the district board of education. No proposal shall be opened previous to the hour designated in the advertisement and none shall be received thereafter.

(b) The district board of education shall reserve the right to reject any or all bids.

(c) All district boards of education local regulations regarding pupil transportation shall be included in the specifications. Each prospective bidder should be given a copy of the contract which the successful bidder will be required to execute. It is recommended that the district boards of education keep a list of the names of all persons who take copies of the specifications.

(d) All bidding shall be designed to prevent fraud, favoritism and extravagance, to safeguard the taxpayers and protect the lowest responsible bidder.

(e) The specifications must be definite, precise and impose common standards.

(f) These specifications and any revisions to these specifications shall be furnished to all prospective bidders and shall not restrict competitive bidding.

(g) Variations from the specifications prescribed by the State Board must be reasonable and are subject to review by the Commissioner and the State Board.

(h) When specifications are purposely formed to deter rather than to invite genuine competition, an award to the intentionally favored bidder will be set aside.

**6:21-15.2 Bidding requirements**

(a) District boards of education shall request bids on a per route basis for regular, nonpublic and in-district handicapped pupils or on a per route, per vehicle, per pupil, per mileage basis for the transportation of out-of-district handicapped pupils.

(b) The bids shall include a separate provision for adjusting the contract as follows:

1. On a per mile basis for public and nonpublic regular and in-district special education routes; and

2. On a per mile, per pupil, per vehicle basis for out-of-district special education routes.

(c) If applicable, the bids shall include a separate provision for an attendant/aid on a per diem basis.

(d) The bid shall also include the following:

1. The cost of liability insurance;

2. An affirmative action statement and questionnaire;

3. A stockholder's disclosure statement;

4. The questionnaire form as prescribed by the Commissioner of Education; and

5. A statement of noncollusion.

(e) A bid bond, cashier's or certified check for five percent of the annual cost of the transportation contract shall accompany the bid.

(f) A surety (performance) bond shall be required equal at least to the amount of one year of the contract. In the case of contracts for more than one year, the bond may be for such amount in excess of the proportionate annual amount as the board shall determine. District boards of education may specify one type of surety bond or allow for either a corporate surety bond or personal surety bond.

(g) Bids are to be placed in a sealed envelope and plainly marked "TRANSPORTATION BID FOR ROUTE OR CONTRACT NO. \_\_\_\_\_ SCHOOL DISTRICT OF \_\_\_\_\_" and presented to the board in session, authorized committee, designated official or employee of the board. The board shall unseal the bids in the presence of the parties bidding and publicly announce contents.

**6:21-15.3 Questionnaire**

The questionnaire form as prescribed by the Commissioner of Education shall be made part of the bid.

**6:21-15.4 (Reserved)****6:21-15.5 Bulk/combo bids**

(a) District boards of education may receive bulk or combination bids.

(b) Bulk or combination bids shall include individual route/contract costs.

(c) If a percentage deduction is stipulated in the bid, it shall be applied to each route/contract bid when all routes/contracts are awarded.

(d) Bulk bidding shall not be used to intentionally eliminate competitive bidding.

**6:21-15.6 Receiving and opening bids**

(a) Unless the proposals are to be received in a meeting of the district board of education, a committee, officer, or employee of the board must be designated to receive the proposals at a time and place designated by the board of education and included in the advertisement for bids. At the time and place so designated and advertised, the board or any committee, officer, or employee designated by the board to do so, shall receive the proposals and proceed to unseal them and publicly announce their contents in the presence of the bidders or their agents. No proposals shall be opened previous to the hour designated in the advertisement and none shall be received thereafter.

(b) A district board of education cannot impose new conditions and bidders cannot be allowed to change bids or make oral bids after they are opened. Specifications may not be modified after bids have been

received and the contract awarded to one of the bidders upon revised specifications.

(c) **Bulletins issued to explain minor details of specifications and to make minor changes will not invalidate the award of a contract to the successful bidder when it appears that all such bulletins were received in advance of the submission of bids by all prospective and actual bidders. The officer of the board responsible for distributing specifications to prospective bidders shall keep a list of their names and addresses so that bulletins can be issued to them, if necessary. If, in good faith, a board finds it has made a mistake in its specifications which cannot be corrected, it may reject all bids and readvertise.**

SUBCHAPTER 16. CONTRACTS

6:21-16.1 Rules

(a) All contracts for transportation or renewals thereof shall be made in triplicate and shall be submitted to the county superintendent of schools for approval on or before September 1 in each year. **Contracts awarded after September 1 of each year shall be submitted to the county superintendent of schools for approval within 30 days after the award of the contract.**

(b) Each contract or renewal [thereof] submitted to the county superintendent shall be accompanied by: [a certified copy of the minutes of the district board of education authorizing the contract.]

1. A bid specification with original contracts;
2. A certified copy of the minutes of the district board of education authorizing the contract;
3. A certificate of insurance;
4. A bid newspaper advertisement with original contracts;
5. A surety (performance) bond;
6. An affirmative action documentation; and
7. A stockholders' disclosure statement with original contracts.

(c) **Non-bid contracts between a district board of education and a parent or guardian, transporting only his or her own child or children shall be accompanied by:**

1. A certified copy of the minutes of the district board of education authorizing the contract; and
2. A certificate of insurance;

[(c) Review and approval of transportation contracts by the county superintendent of schools is a review and approval as to form only. The final determination of State transportation aid, if any, that is payable to a district board of education for approved transportation expenditures shall be made by the Bureaus of Pupil Transportation and Audit within the Division of Finance of the State Department of Education.]

(d) **Notwithstanding the county superintendent's approval, as noted in N.J.A.C. 6:21-7.1, State aid shall be subject to modifications by the Commissioner of Education for good cause shown.**

[(d)] (e) If the county superintendent of schools approves the contract or renewal, one copy shall be filed with the county superintendent, one with the district board of education, and one with the contractor.

[(e) If the county superintendent of schools approves the transportation contract or renewal thereof, this does not by itself guarantee that the board of education will receive State aid for pupil transportation expenditures.]

(f) (No change.)

6:21-16.3 Rules constitute part of contract

(a) (No change.)

(b) If any person operating a school bus under contract with a district board of education shall fail to comply with any of the rules governing pupil transportation, the board of education shall immediately notify such person in writing of his or her failure to comply.

(c) If the violation is repeated, the district board of education may require the violator to show cause at a hearing why his or her failure to comply should not be deemed a breach of contract.

(d) If, after due notice and hearing, the district board of education shall determine that a breach of contract exists; it may call upon the bondsman or surety company, as the case may be, to perform the contract or to reimburse the board for any financial loss resulting from the breach of the contract, and may annul the contract.

(e) Any person operating a bus under contract may appeal from the action of the district board of education in the manner provided by N.J.S.A. 18A:6-24, 25, [and 27 and 18A:6-]27, 28 and 29.

6:21-16.4 Term of contract

(a) **The district board of education shall [(Definitely)] indicate the term of the contract not exceeding four years. [(and alter bid form, if necessary.)]**

(b) Any contract for transportation is without force or effect until approved by the county superintendent of schools.

6:21-16.5 Awarding contracts

(a) **Prior to the opening of school and in sufficient time to publicly advertise for bid, district boards of education shall assess their pupil transportation needs. If the assessment indicates that pupil transportation services in the aggregate will exceed the statutory bid limit, except for contracts qualifying for renewal, all transportation services shall be bid in accordance with N.J.S.A. 18A:39-3.**

[(a)] (b) The contract shall be awarded to the lowest responsible bidder by formal action of the district board of education in a public meeting. The board is not authorized to delegate its power to enter into a transportation contract.

(c) **Contracts for the transportation of handicapped children to and from any school district shall be awarded by formal action of the district board of education in a public meeting to the lowest responsible bidder and whose bid the board has determined is the least costly method. Documentation shall be on file to support the district board of education's determination for the least costly method. The board is not authorized to delegate its power to enter into a transportation contract.**

[(b)] (d) Any award of a contract made by a district board of education after advertisement must be according to the terms advertised to prospective bidders. Each bidder shall be compelled to conform to every substantial condition imposed upon other bidders.

[(c)] (e) After a contract has been awarded, a bidder cannot be relieved from conforming to the conditions imposed upon him or her in the specifications, and cannot substitute something which does not conform to the specifications.

[(d)] (f) A district board of education cannot reject a bid of the lowest bidder upon the ground that he or she is not responsible without giving him or her a hearing upon the facts. To determine that a bidder is not responsible, the district board of education must find as a fact, after notice and a public hearing, that the bidder is so lacking in experience, financial ability, equipment and facilities [as] to justify [the belief upon the part of fair minded men] that he or she would be unable to carry out the contract, if awarded [to him].

[(e)] (g) The lack of ability upon the part of a contractor to work in harmony or the district board[s] of education's inability to enforce the terms of a previous contract cannot be controlling factors in determining the bidder's responsibility[.] [and disputes] **Disputes involving controverted questions of fact with reference to the performance of a previous contract do not constitute grounds for declaring a bidder irresponsible, if such disputed matters can be taken care of under a contract properly safeguarding the public interest[.] with a contractor who is financially responsible.**

6:21-16.6 High, collusive or no bids

**If on two occasions no bids were received, or on two occasions bids were rejected by the district board of education because they were too high, contracts shall be awarded pursuant to N.J.S.A. 18A:18A-5(c) and (d).**

6:21-16.7 Quoted contracts

(a) **Quotations may be sought after the opening of school for unanticipated to and from school transportation services. The process of soliciting quotations cannot be used by district boards of education to intentionally split transportation routes into smaller parts so as to avoid reaching the amount determined by the Governor as the formal competitive bidding requirement.**

(b) **Quoted contracts may be issued for unanticipated to and from school transportation services provided the following requirements are met.**

1. At least three quotations shall be sought;
2. Quotations shall be solicited on a per diem basis;

3. Quoted contracts under the bid threshold may be in effect for the balance of the school year but must be included in the aggregate cost of transportation services for the ensuing school year;

4. Quoted contracts over the bid threshold may be issued for a period not to exceed 90 calendar days. The competitive bid process must then be completed and awarded contracts implemented for the balance of the school year; and

5. Quoted contracts shall not be renewed.

#### 6:21-16.8 Renewing contract

(a) Annual extensions of an original contract, approved by the county superintendent of schools, are permitted provided:

1. The contract was entered into through competitive bidding;

2. The terms of contract remain the same; and

3. There is no increase in the annual amount of the contract to the district board of education or the increase in the original contractual base amount as a result of such extension and not result in an "effective increase" of more than 30 percent, except in cases where a student rider is newly assigned to a route during the school year and extra mileage is necessary. Any such arrangement shall be approved by the county superintendent of schools and shall be bid for the next school year.

#### 6:21-16.9 Addendum

(a) An addendum shall be required to adjust an existing contract or contract renewal.

1. An addendum to contract/contract renewal for regular pupils and in-district handicapped pupils shall be calculated based on the increase/decrease mileage adjustment stated in the original bid.

2. An addendum to contract/contract renewal for out-of-district handicapped pupils bid on a per route, per pupil, per mileage or per vehicle basis, shall be calculated based on the increase/decrease adjustment stated in the original bid.

3. An addendum to contract/contract renewal for the purpose of adding an attendant/aide may be a negotiated cost, provided the cost does not exceed the bid threshold.

(b) An addendum to contract/contract renewal shall be submitted on the prescribed Contract Addendum form to the county superintendent of schools for approval within 30 days of the adjustment.

(c) Increased bonding is required when an addendum is added to an existing contract increasing the cost.

1. When an addendum is added to the contract, increasing the cost, additional bonding coverage will not be required if the pro-rated cost of the original contract plus the additional cost of the addendum(s) does not exceed the amount of the original bond.

(d) A certified copy of the minutes of the district board of education authorizing the adjustment shall accompany the Contract Addendum form.

#### 6:21-16.10 Transferring contracts and contract renewals

(a) Whenever a contractor has entered into or intends to enter into an agreement to sell or assign to a purchaser all of the contractor's rights and liabilities with respect to the transportation contract between the district board of education and the contractor, such assignment requires the approval of the district board of education and the county superintendent of schools.

(b) The transfer shall impose no additional cost to the district board of education.

(c) All terms of the original contract shall remain in effect.

(d) The assignment between the district board of education and the purchaser shall not become effective until the purchaser provides:

1. A certificate of insurance;

2. A surety (performance) bond;

3. A stockholders' disclosure statement; and

4. Affirmative action documentation.

(e) The prescribed "Pupil Transportation Contract Transfer Agreement" shall be completed for each contract.

(f) Certified board minutes approving the transfer of the contract must accompany the "Pupil Transportation Contract Transfer Agreement."

#### 6:21-16.11 Joint transportation agreements

(a) Two or more district boards of education may provide jointly for the transportation of pupils to and from any school(s), within or outside the district or counties.

(b) Whenever in the judgment of the county superintendent of schools transportation of pupils could be more economically accomplished by joint transportation, he or she may order such joint transportation, assign the administration to one district board of education as host and prorate the cost on a per pupil mileage basis to the joining district boards of education.

(c) The district board of education providing the transportation, either by district-owned vehicle or contracted vehicle, will be referred to as the "host".

(d) The "host" district board of education will be responsible for initiating the joint agreement.

(e) Four copies of the joint transportation agreement form prescribed by the Commissioner shall be submitted to the county superintendent of schools for approval. Joint agreements between district boards of education located in more than one county shall be submitted to both county superintendents of schools for approval.

(f) Certified copies of board minutes for each district board of education involved in the joint agreement shall accompany the joint transportation agreement submitted to the county superintendent of schools.

### SUBCHAPTER 17. INSURANCE

#### 6:21-17.1 General provisions

(a) [Each contractor shall furnish liability insurance for bodily injury or death in the following minimum amounts: All vehicles transporting pupils, \$300,000.00 for one person, \$500,000.00 for one accident.] Each contractor and district board of education shall furnish liability insurance for bodily injury and property damage in the amount of \$1,000,000 combined single limit per occurrence for all vehicles which are used for pupil transportation to and from school and school related activities.

(b) [Such insurance] Insurance shall be obtained through a company authorized to insure in New Jersey.

(c) [In lieu of the policy or certificate of insurance hereinbefore prescribed, self-insuring corporations may file the certificate prescribed in N.J.S.A. 48:4-12 and 13.] Self-insured transportation contractors and district boards of education as provided in N.J.S.A. 48:4-12 and 13 shall file a certificate of self-insurance with the county superintendent of schools.

(d) Policies or certificates of insurance shall accompany all contracts or renewals [thereof] when [such] transportation contracts or renewals are submitted to the county superintendent of schools for approval.

(e) Policies or certificates of insurance shall be submitted to the county superintendent of schools for approval whenever policies are amended, revised or renewed.

(f) Transportation contractors and district boards of education shall comply with these regulations as of September 1, 1990.

### SUBCHAPTER 18. INSPECTION

#### 6:21-18.1 Applicability

(a) The provisions of this subchapter shall be applicable to all vehicles which are registered in this State, owned or leased by a district board of education, school bus contractor or individual under contract with a district board of education and used for transportation of pupils to and from school and/or to and from school related [school] activities.

(b) (No change.)

#### 6:21-18.2 Division of Motor Vehicles inspection

(a) No school vehicle registered with the Division of Motor Vehicles which is owned by or under contract with a district board of education shall be used for transportation of pupils to and from school and/or to and from school related [school] activities, as defined in N.J.S.A. 18A:39-1, unless such school vehicle is issued a school bus inspection sticker by the Division of Motor Vehicles. School vehicles shall be inspected or reinspected at Motor Vehicle Inspection Stations.

(b) (No change.)

(c) Owners and operators of buses shall submit evidence of inspection by the Division of Motor Vehicles to the county superintendent of schools at such time as he or she may deem necessary.

6:21-18.3 Department of Transportation inspection

(a) No autobus under the jurisdiction of the Department of Transportation and under contract with a district board of education shall be used for transportation of pupils to and from school [and/or to and from school related activities], as defined in N.J.S.A. 18A:39-1, unless such autobus is authorized for school use on the certificate of inspection issued by the Department of Transportation.

(b) An autobus under the jurisdiction of the Department of Transportation is exempt from authorization for school use on the certificate of inspection issued by the Department of Transportation when being used on a preset franchised route and schedule or chartered for school related activities.

[(b)] (c) The Department of Transportation is responsible for the inspection and certification for school use of the omnibus vehicle registration.

[(c)] (d) Owners or operators of buses [approved] authorized for school use by the Department of Transportation shall submit evidence of such approval to the county superintendent of schools at such time as he or she may deem necessary.

(e) A bus authorized for school use by the Department of Transportation may be inspected by a county superintendent for compliance with the requirements of this chapter.

6:21-18.4 Responsibility for reports and records

(a) (No change.)

(b) Inspection records [must] shall include:

1.-4. (No change.)

**SUBCHAPTER 19 PUPIL TRANSPORTATION GOVERNANCE AND ADMINISTRATION**

6:21-19.1 General Requirements

(a) The Commissioner shall provide for a thorough review of district boards of education transportation contracts and reports for form and accuracy and to determine compliance with this chapter and N.J.S.A. 18A:39.1 et seq.

(b) The Commissioner shall provide for an evaluation of district boards of education pupil transportation operations and fiscal procedures to determine compliance with the provisions of this chapter.

(c) The Commissioner may withhold transportation aid for any district board of education who is noncompliant with the provisions set forth in this chapter.

6:21-19.2 Evaluation Procedures

(a) District boards of education shall annually submit pupil transportation reports to the county superintendent of schools as required by law and regulation for reviews as to form and accuracy including recommendations for approval of state transportation aid.

(b) District boards of education must submit, by November 1st of each year, the district audit check list for pupil transportation form as prescribed by the Commissioner to the county superintendent of schools for review.

(c) The county superintendent of schools shall conduct a review of district boards of education transportation costs every five years in accordance with N.J.A.C. 6:8-4.3(a)10vi.

6:21-19.3 Regulatory review

(a) The Bureau of Pupil Transportation field representative shall conduct quarterly reviews of the county superintendent's administration of pupil transportation. This review shall include a sampling of records that have been submitted to the county superintendent of schools by district boards of education to determine compliance with the provisions of this chapter.

(b) The Bureau of Pupil Transportation shall conduct on site annual reviews of district boards of education pupil transportation procedures, operations and fiscal records as directed by the Commissioner.

6:21-19.4 Corrective plan

Any district board of education found to be deficient as a result of the Bureau of Pupil Transportation review shall submit a corrective

action plan addressing the specific recommendations to the county superintendent of schools.

6:21-19.5 Compliance investigation

(a) The Division of Compliance shall conduct a complete inspection of pupil transportation procedures, operations, and costs for any district board of education identified as deficient in the administration of pupil transportation as a result of the Bureau of Pupil Transportation review or State Department of Education monitoring process.

(b) The compliance investigation will be conducted under the supervision of the Director of the Division of Compliance under any one of the following circumstances:

1. The Bureau of Pupil Transportation review indicates that conditions exist within the district that may prevent the successful implementation of a corrective action plan.

2. A district board of education fails to implement and adhere to the corrective action plan that has been approved by the county superintendent of schools; or

3. A district fails to achieve certification based upon deficiencies noted in pupil transportation and does not demonstrate reasonable progress pursuant to N.J.A.C. 6:8-5.2(c).

**ENVIRONMENTAL PROTECTION**

(a)

**DIVISION OF HAZARDOUS WASTE MANAGEMENT  
DIVISION OF SOLID WASTE MANAGEMENT**

**Civil Administrative Penalties and Adjudicatory Hearings**

**Proposed New Rules: N.J.A.C. 7:26-5**

Authorized By: Christopher J. Daggett, Commissioner, Department of Environmental Protection.

Authority: N.J.S.A. 13:1E-1 et seq., particularly 13:1E-6 and 13:1E-9, and P.L. 1989, c.34, particularly section 20.

DEP Docket Number: 037-89-08.

Proposal Number: PRN 1989-461.

A public hearing concerning the proposed new rules will be held on:

Monday, October 16, 1989

10:00 A.M. to 12:00 noon

Trenton War Memorial Building

Veteran's Hall

Trenton, New Jersey

Submit written comments by November 6, 1989 to:

Carl Will, Esq.

Division of Regulatory Affairs

Department of Environmental Protection

401 E. State Street, CN 402

Trenton, New Jersey 08625

The agency proposal follows:

**Summary**

The Legislature, pursuant to P.L. 1986, c.170, Section 1, amending the Solid Waste Management Act, N.J.S.A. 13:1E-1 et seq., increased the maximum allowable civil administrative penalties which the Department has the authority to assess for violations of the Act. The Act requires the Commissioner to adopt civil administrative penalty rules as a condition precedent to the Department's assessment of civil administrative penalties between \$25,000 and \$50,000, and to the Department's assessment of civil administrative penalties of more than \$2,500 per day for each day during which a violation continues. Accordingly, the Department hereby proposes such rules.

Subsequently, the Legislature, pursuant to P.L. 1989, c.34, enacted the Comprehensive Regulated Medical Waste Management Act, amending and supplementing the Act, and authorizing the imposition of civil administrative penalties up to the maximum allowable amounts set forth in the Act.

The following new rules establish civil administrative penalty assessment procedures and amounts for violations of the Act, or any rule promulgated, any administrative order, permit, license or other operating authority issued, any district solid waste management plan approved, or

any Part A permit application filed, pursuant to the Act. The Act, at N.J.S.A. 13:1E-9(e), and at section 20 of P.L. 1989, c.34, requires the Department, when promulgating civil administrative penalty rules, to consider the operational history of the violator or the facility at which the violation occurred, the severity of the violation, the measures taken by the violator to mitigate or prevent further violations, and whether or not the penalty will maintain an appropriate deterrent for violations of the Act. The Department proposes to assess civil administrative penalties using a base penalty for violations of Department rules governing hazardous waste management. The Department intends to assess civil administrative penalties using the base penalty, as adjusted by the severity factors, in the majority of penalty assessment cases. For a violation of a requirement or condition of a permit, license or other operating authority, the Department will identify the corresponding requirement of any rule listed in N.J.A.C. 7:26-5.4(g) and determine the amount of the civil administrative penalty on the basis of the rule provision violated. The Department will apply the severity factors proposed in N.J.A.C. 7:26-5.4(f) to these base penalties to determine the amount of the civil administrative penalty.

The Department has factored into the base penalty the severity of the violation, actions by the violator to mitigate or prevent further violations and the deterrent effect of the penalty by establishing different base penalties for different violations as proposed in N.J.A.C. 7:26-5.4.

The Department proposes to factor in the operational history of the facility at which the violation occurred through the use of the severity factors in N.J.A.C. 7:26-5.4(f)3i through iv. The proposed procedure would allow the Department to increase the civil administrative penalty depending on the type and timing of prior violations.

The Department also proposes a civil administrative penalty assessment procedure for cases where the civil administrative penalty amount determined under N.J.A.C. 7:26-5.4 would result in a civil administrative penalty which would not, among other factors, provide a sufficient deterrent or otherwise meet the objectives of the Act, as amended by P.L. 1986, c.170. The Department proposes to reserve the discretion to use the matrix proposed in N.J.A.C. 7:26-5.5 to determine the amount of the civil administrative penalty if circumstances such as those described in N.J.A.C. 7:26-5.5(a) exist. Such provisions are necessary to ensure that the proposed rules do not result in limiting the Department's discretion to assess civil administrative penalties which are high enough to provide appropriate deterrent and to assure protection of human health and the environment, but in no event more than \$50,000 per violation.

The Department further proposes to establish procedures governing requests for adjudicatory hearings, with respect to the assessment of civil administrative penalties or the issuance of administrative orders.

The rule summary in N.J.A.C. 7:26-5.4(g), which summarizes certain provisions of N.J.A.C. 7:26-7 through N.J.A.C. 7:26-12, is provided for informational purposes only and shall have no other legal effect.

#### Social Impact

The Department's proposal to establish civil administrative penalty assessment rules pursuant to the Act will have a positive social impact by discouraging noncompliance with the Act and associated rules, administrative orders, permits, licenses or other operating authorities issued, district solid waste management plans approved, and Part A permit applications filed. By amending the Act to increase the penalties which the Department may assess, it is the clear intent of the Legislature that the Department should realign its penalty assessment process to increase penalties. The proposed new rules are the result of that reevaluation. These rules also result from the Legislature's approval on March 6, 1989 of the Comprehensive Regulated Medical Waste Management Act, which amended and supplemented the Act and which authorized the imposition of civil administrative penalties up to the same increased amounts as set forth in the Act. Accordingly, the civil penalties which are likely to result from use of these rules will be, in many cases, higher than those presently being assessed by the Department.

#### Economic Impact

The proposed new rules should decrease the amount of Department resources required to assess and collect civil administrative penalties, by establishing an assessment system which, in most cases, will be by application of the Base Penalty Schedule and the severity factors in N.J.A.C. 7:26-5.4(b). Further, if this assessment system is used, the resulting penalty will involve the application of no discretionary standards.

These rules will result in economic impact on violators equal to the amount of the higher penalties assessed against the violators. It is expected, however, that the additional compliance with the Act and associated rules which will result from application of the proposed rules

will actually result in assessment by the Department of fewer penalties, thereby lessening the industry-wide economic impact of the proposal.

#### Environmental Impact

The proposed new rules are intended to serve as a greater deterrent to those who would violate environmental statutes and rules. The Department anticipates that, by providing extensive civil administrative penalties for violations of the Act and associated rules, the regulated community will have a stronger incentive to conduct their activities in conformance with the Department's rules, thereby better protecting public health and the natural resources of the State. The Department's action is consistent with the decision of the Appellate Division of the New Jersey Superior Court in *State of New Jersey Department of Environmental Protection and the New Jersey Pinelands Commission v. John Lewis*, 215 N.J. Super. 564 (App. Div. 1987). That Court decision stated that penalties should be assessed in an amount which will "effectively strip (violators) not only of profits made in connection with their illegal (activities), but also in a sufficient amount to deter others from polluting the environment. The penalty imposed must be large enough so as not to become the equivalent of a permit fee or a mere cost of doing business." *Id.* 215 N.J. Super., at 576. Those who violate a State statute should neither profit by nor escape responsibility for their actions.

#### Regulatory Flexibility Analysis

The proposed new rules will not impose reporting, recordkeeping, or other compliance requirements on small businesses. The purpose of these rules is to supplement the enforcement authority for existing compliance requirements. The Department, in accordance with its mandate to protect human health and the environment, has determined that in assessing a penalty it would not be appropriate to require consideration of the size of the business. It has been the Department's experience that statutory violations and the threat to human health and the environment caused thereby have no correlation to business size.

Full text of the proposal follows:

### SUBCHAPTER 5. CIVIL ADMINISTRATIVE PENALTIES AND REQUESTS FOR ADJUDICATORY HEARINGS

#### 7:26-5.1 Scope and purpose

(a) This subchapter shall govern the Department's assessment of civil administrative penalties for violations of the Solid Waste Management Act, N.J.S.A. 13:1E-1 et seq., including the Comprehensive Regulated Medical Waste Management Act, P.L. 1989, c.34, amending and supplementing the Solid Waste Management Act (hereinafter "the Act"), including violation of any rule promulgated, any administrative order, permit, license or other operating authority issued, any district solid waste management plan approved, or any Part A permit application filed, pursuant to the Act. This subchapter shall also govern the procedures for requesting adjudicatory hearings on a notice of civil administrative penalty assessment or an administrative order.

(b) The Department may assess a civil administrative penalty of not more than \$50,000 for each violation of each provision of the Act, or any rule promulgated, any administrative order, permit, license or other operating authority issued, any district solid waste management plan approved, or any Part A permit application filed, pursuant to the Act.

(c) Each day during which a violation continues shall constitute an additional, separate and distinct violation.

(d) Neither the assessment of a civil administrative penalty nor the payment of any such civil administrative penalty shall be deemed to affect the availability of any other enforcement provision provided for by N.J.S.A. 13:1E-1 et seq. or any other statute, in connection with the violation for which the assessment is levied.

(e) Nothing in this subchapter is intended to effect the Department's authority to revoke or suspend any permit, license or other operating authority issued under the Act. Specifically, the Department may revoke or suspend a permit, license or other operating authority, without regard to whether or not a civil administrative penalty has been or will be assessed pursuant to this subchapter.

(f) For purposes of this subchapter, any person who undertakes or performs an obligation imposed upon another person pursuant to the Act, or any rules promulgated, any administrative order,

permit, license or other operating authority issued, any district solid waste management plan approved, or any Part A permit application filed, pursuant to the Act, may at the discretion of the Department be subject to a civil administrative penalty pursuant to this subchapter in the same manner and in the same amount as such other person.

7:26-5.2 Procedures for assessment and payment of civil administrative penalties

(a) In order to assess a civil administrative penalty under the Act, for violation of the Act, or any rule promulgated, any administrative order, permit, license or other operating authority issued, any district solid waste management plan approved, or any Part A permit application filed, pursuant to the Act, the Department shall, by means of notice of civil administrative penalty assessment, notify the violator by certified mail (return receipt requested) or by personal service. The Department may, in its discretion, assess a civil administrative penalty for more than one violation in a single notice of civil administrative penalty assessment or in multiple notices of civil administrative penalty assessment. This notice of civil administrative penalty assessment shall:

1. Identify the section of the Act, rule, administrative order, permit, license, district solid waste management plan or Part A permit application violated;
2. Concisely state the facts which constitute the violation;
3. Specify the amount of the civil administrative penalty to be imposed; and
4. Advise the violator of the right to request an adjudicatory hearing, pursuant to the procedures in N.J.A.C. 7:26-5.3.

(b) Payment of the civil administrative penalty is due upon receipt by the violator of the Department's final order of a contested case or when a notice of civil administrative penalty assessment becomes a final order, as follows:

1. If no hearing is requested pursuant to N.J.A.C. 7:26-5.3, the notice of civil administrative penalty assessment becomes a final order on the 21st day following receipt by the violator of the notice of civil administrative penalty assessment;
2. If a hearing is requested pursuant to N.J.A.C. 7:26-5.3 and the Department denies the hearing request, a notice of civil administrative penalty assessment becomes a final order upon receipt by the violator of notice of such denial; or
3. If a hearing is requested pursuant to N.J.A.C. 7:26-5.3 and an adjudicatory hearing is conducted, a notice of civil administrative penalty assessment becomes a final order upon receipt by the violator of a final order of a contested case.

7:26-5.3 Procedures to request an adjudicatory hearing to contest an administrative order and/or a notice of civil administrative penalty assessment, and procedures for conducting adjudicatory hearings

(a) To request an adjudicatory hearing to contest an administrative order and/or a notice of civil administrative penalty assessment issued pursuant to the Act, the violator shall submit the following information in writing to the Department:

1. The name, address, telephone number and EPA Identification Number (if applicable) of the violator and its authorized representative;
2. The violator's defenses, to each of the Department's findings of fact in the findings section of the administrative order or notice of civil administrative penalty assessment, stated in short and plain terms;
3. An admission or denial of each of the Department's findings of fact in the findings section of the administrative order or notice of civil administrative penalty assessment. If the violator is without knowledge or information sufficient to form a belief as to the truth of a finding, the violator shall so state and this shall have the effect of a denial. A denial shall fairly meet the substance of the findings denied. When the violator intends in good faith to deny only a part or a qualification of a finding, the violator shall specify so much of it as is true and material and deny only the remainder. The violator may not generally deny all of the findings but shall make all denials as specific denials of designated findings. For each finding which the

violator denies, the violator shall allege the fact or facts as the violator believes such fact or facts to be;

4. Information supporting the request and specific reference to or copies of all written documents relied upon to support the request;

5. An estimate of the time required for the hearing (in days and/or hours); and

6. A request, if necessary, for a barrier-free hearing location for physically disabled persons.

(b) If the Department does not receive the written request for a hearing within 20 days after receipt by the violator of the notice of a civil administrative penalty assessment and/or an administrative order being challenged, the Department shall deny the hearing request.

(c) If the violator fails to include all the information required by (a) above, the Department may deny the hearing request.

(d) All adjudicatory hearings shall be conducted in accordance with the Administrative Procedure Act, N.J.S.A. 52:14B-1 et seq., and the Uniform Administrative Procedure Rules, N.J.A.C. 1:1.

7:26-5.4 Civil administrative penalties for violations of rules adopted pursuant to the Act

(a) The Department may assess a civil administrative penalty pursuant to this section of not more than \$50,000 for each violation of each requirement of any rule listed in N.J.A.C. 7:26-5.4(g).

(b) Each violation of a rule listed in N.J.A.C. 7:26-5.4(g) shall constitute an additional, separate and distinct violation.

(c) Each day during which a violation continues shall constitute an additional, separate and distinct violation.

(d) For each parameter that is required to be monitored, sampled or reported, the failure to so monitor, sample or report shall constitute an additional, separate and distinct violation.

(e) Where any requirement of any rule listed in N.J.A.C. 7:26-5.4(g) may pertain to more than one act, condition, occurrence, item, unit, waste or parameter, the failure to comply with such requirement as it pertains to each such act, condition, occurrence, item, unit, waste or parameter shall constitute an additional, separate and distinct violation.

(f) The Department shall determine the amount of a civil administrative penalty for each violation of any rule listed in N.J.A.C. 7:26-5.4(g) on the basis of the provision violated, according to the following procedure. For a violation of a requirement or condition of an administrative order, permit, license or other operating authority, the Department may in its sole discretion identify the corresponding requirement of any rule summary listed in N.J.A.C. 7:26-5.4(g) and determine the amount of the civil administrative penalty on the basis of the rule provision violated.

1. Identify the rule violated as listed in N.J.A.C. 7:26-5.4(g)7 through 12;

2. Identify the corresponding base penalty dollar amount for the rule violated as listed in N.J.A.C. 7:26-5.4(g)7 through 12;

3. Multiply the base penalty dollar amount times the following multipliers for each factor to obtain the severity penalty component, as applicable:

| SEVERITY FACTOR  | MULTIPLIER |
|--|------------|
| i. Violator had violated the same rule less than 12 months prior to the violation .....  | 1.00       |
| ii. Violator had violated a different rule less than 12 months prior to the violation .....  | 0.50       |
| iii. Violator had violated the same rule during the period which began 24 months prior to the violation and ended 12 months prior to the violation .....   | 0.50       |
| iv. Violator had violated a different rule during the period which began 24 months prior to the violation and ended 12 months prior to the violation ..... | 0.25       |

4. To obtain the civil administrative penalty, add all of the severity penalty components pursuant to (f)3 above, to the base penalty. If the sum total exceeds \$50,000, then the civil administrative penalty shall be \$50,000.

**PROPOSALS**

**Interested Persons see Inside Front Cover**

**ENVIRONMENTAL PROTECTION**

|  |   |                |
|--|---|----------------|
| EXAMPLE: Base penalty (for violation of N.J.A.C. 7:26-7.4(a)6) | = | \$1,000        |
| Subparagraph (f)3iii applies: 0.50 x 1000                      | = | 500            |
| Subparagraph (f)3iv applies: 0.25 x 1000                       | = | + 250          |
| Civil administrative penalty                                   |   | <u>\$1,750</u> |

5. For the purpose of this section, violation of the "same rule" means violation of the same specific requirement of a rule. Where a rule has a list of specific requirements, the same item on the list must be violated to be considered violation of the "same rule"; and

(g) The rule summary in this subsection, which summarizes certain provisions in N.J.A.C. 7:26-7 through N.J.A.C. 7:26-12, is provided for informational purposes only. In the event that there is a conflict between the rule summary in N.J.A.C. 7:26-5.4(g) and a provision in N.J.A.C. 7:26-7 through N.J.A.C. 7:26-12, then the provision in N.J.A.C. 7:26-7 through N.J.A.C. 7:26-12 shall prevail. The number of the following subsections corresponds to the number of the corresponding subchapter in N.J.A.C. 7:26.

1.-6. (Reserved)

7. The violations of N.J.A.C. 7:26-7, Labeling, Records and Transportation Requirements, and the civil administrative penalty amounts for each violation, are as set forth in the following table.

| RULE          | RULE SUMMARY  | BASE PENALTY |
|---------------|---|--------------|
| N.J.A.C.      |   |              |
| 7:26-7.1(a)   | Failure to placard vehicle containing hazardous waste.  | \$5,000      |
| 7:26-7.1(b)   | Hazardous waste facility accepting hazardous waste in a vehicle not properly placarded.   | \$2,000      |
| 7:26-7.2(a)   | Failure to label containers containing hazardous waste with manifest numbers.   | \$500        |
| 7:26-7.2(b)   | Failure of generator to ensure all containers are of proper construction type or properly labeled.  | \$2,000      |
| 7:26-7.2(c)   | Removal of container markings prior to emptying and cleaning.   | \$3,000      |
| 7:26-7.2(d)   | Transfer of hazardous waste to new container (in transit) without labeling with manifest numbers.   | \$500        |
| 7:26-7.2(e)   | Hazardous waste facility accepting hazardous waste containers that are not properly labeled or marked.  | \$2,000      |
| 7:26-7.3(a)1  | Failure to use manifest forms from the Department for hazardous waste originating in New Jersey.  | \$300        |
| 7:26-7.3(a)2  | Failure to use approved manifest forms for hazardous waste originating in another state and destined for New Jersey.                                    | \$300        |
| 7:26-7.3(a)3  | Failure to use approved manifest forms for hazardous waste originating in New Jersey and destined for another state.                                    | \$300        |
| 7:26-7.4(a)1  | Failure of generator to have EPA identification number before it treats, stores, transports, offers for transportation, or disposes of hazardous waste. | \$2,000      |
| 7:26-7.4(a)2  | Failure of generator to have EPA identification number before it offers hazardous waste to a hazardous waste hauler or TSD facility.                    | \$2,000      |
| 7:26-7.4(a)3  | Failure of generator to prepare a manifest before transporting or offering for transport hazardous waste off-site.                                      | \$10,000     |
| 7:26-7.4(a)4i | Failure of generator to supply generator's name, mailing address, site address, or phone number on the manifest.  | \$300        |

|                  |  |          |
|------------------|--|----------|
| 7:26-7.4(a)4ii   | Failure of generator to supply generator's EPA I.D. number on the manifest.  | \$300    |
| 7:26-7.4(a)4iii  | Failure of generator to supply hauler(s) name, phone number, or New Jersey registration number on the manifest.  | \$300    |
| 7:26-7.4(a)4iv   | Failure of generator to supply hauler(s) EPA I.D. number on the manifest.  | \$300    |
| 7:26-7.4(a)4v    | Failure of generator to supply designated facility's name, address or phone number on the manifest.  | \$1,000  |
| 7:26-7.4(a)4vi   | Failure of generator to supply designated facility's EPA I.D. number on the manifest.  | \$1,000  |
| 7:26-7.4(a)4vii  | Failure of generator to list name, type, or quantity of waste being shipped on the manifest  | \$1,000  |
| 7:26-7.4(a)4viii | Failure of generator to list special handling instructions on the manifest.  | \$300    |
| 7:26-7.4(a)ix    | Failure of generator to supply waste reuse facility identification number on the manifest.   | \$300    |
| 7:26-7.4(a)5i    | Failure of generator to sign manifest.   | \$2,000  |
| 7:26-7.4(a)5ii   | Failure of generator to obtain signature of initial hauler and date of acceptance on the manifest.   | \$1,000  |
| 7:26-7.4(a)5iii  | Failure of generator to retain one copy of manifest or to forward one copy to state of origin or one to state of destination.  | \$1,000  |
| 7:26-7.4(a)6     | Failure of hauler, unable to deliver hazardous waste to designated facility, to notify generator for instructions; or failure of generator to provide further instructions to hauler unable to deliver hazardous waste to designated facility. | \$1,000  |
| 7:26-7.4(a)7     | Failure of generator shipping hazardous waste within the U.S. solely by railroad or solely by water to send three copies of approved manifest form signed and dated to owner or operator of designated facility.                               | \$1,000  |
| 7:26-7.4(a)8     | Failure of generator to send at least three copies of signed and dated manifest for rail shipments of hazardous waste within the U.S. to next non-rail hauler, designated facility, or last rail hauler.                                       | \$10,000 |
| 7:26-7.4(a)10    | Generator offering acute hazardous waste or toxic waste for final land disposal in New Jersey.   | \$10,000 |
| 7:26-7.4(c)      | Failure of generator to comply with requirements for shipping hazardous wastes out of the U.S.   | \$10,000 |
| 7:26-7.4(d)      | Failure of generator shipping wastes out of the U.S. to file an exception report.  | \$10,000 |
| 7:26-7.4(e)2     | Failure of generator to utilize a properly registered hauler.  | \$5,000  |
| 7:26-7.4(e)2     | Failure of generator to utilize transporter with registration number properly displayed.   | \$500    |
| 7:26-7.4(e)3     | Generator designating an unauthorized facility, or a waste reuse facility which had not received a waste reuse identification number, on the manifest.   | \$1,000  |
| 7:26-7.4(e)4     | Generator shipping or permitting the shipment of hazardous waste to an unauthorized facility, or to a waste reuse facility which had not received a waste reuse identification number.   | \$25,000 |

**ENVIRONMENTAL PROTECTION**

**PROPOSALS**

|                 |  |          |                   |   |          |
|-----------------|--|----------|-------------------|---|----------|
| 7:26-7.4(f)1    | Failure of generator to keep copy of manifest for three years.   | \$1,000  | 7:26-7.5(d)8i(1)  | Failure of rail hauler accepting hazardous waste from non-rail hauler to sign or date manifest.   | \$2,000  |
| 7:26-7.4(f)2    | Failure of generator to keep copy of annual report or exception report for three years.  | \$500    | 7:26-7.5(d)8i(2)  | Failure of rail hauler accepting hazardous waste from non-rail hauler to return a signed copy of manifest to non-rail hauler.   | \$500    |
| 7:26-7.4(f)3    | Failure of generator to keep copy of manifest during course of unresolved enforcement action or as requested by the Department.                          | \$1,000  | 7:26-7.5(d)8i(3)  | Failure of rail hauler accepting hazardous waste from non-rail hauler to forward manifest to next non-rail hauler, designated facility, or last rail hauler in United States. | \$1,000  |
| 7:26-7.4(f)3    | Failure of generator to keep copy of annual report or exception report during course of unresolved enforcement action or as requested by the Department. | \$500    | 7:26-7.5(d)8ii    | Failure of rail hauler to ensure appropriate shipping paper accompanies hazardous waste at all times.   | \$10,000 |
| 7:26-7.4(g)1    | Failure of generator to submit annual report of manifest activities by March 1.  | \$500    | 7:26-7.5(d)8iv(1) | Failure of rail hauler delivering hazardous waste to designated facility to obtain date of delivery or handwritten signature of owner or operator of designated facility.     | \$2,000  |
| 7:26-7.4(g)2    | Failure of generator who stores hazardous waste for more than 90 days to submit annual report summarizing treatment and disposal activities by March 1.  | \$500    | 7:26-7.5(d)8iv(2) | Failure of rail hauler delivering hazardous waste to designated facility to retain copy of manifest.  | \$500    |
| 7:26-7.4(h)     | Failure of generator to comply with exception reporting requirements.  | \$1,000  | 7:26-7.5(d)8v(1)  | Failure of rail hauler delivering hazardous waste to non-rail hauler to obtain date of delivery or handwritten signature of non-rail hauler.                                  | \$2,000  |
| 7:26-7.4(j)1    | Generator offering hazardous waste, to waste reuse facility, without complying with applicable requirements.   | \$25,000 | 7:26-7.5(d)8v(2)  | Failure of rail hauler delivering hazardous waste to non-rail hauler to retain copy of manifest.  | \$500    |
| 7:26-7.5(b)3i   | Failure of hauler to compile list of sites corresponding to each manifested shipment of X700-series hazardous waste.                                     | \$1,000  | 7:26-7.5(d)8vi    | Failure of non-rail hauler accepting hazardous waste from rail hauler to sign or date manifest.   | \$2,000  |
| 7:26-7.5(b)3ii  | Failure of hauler to include name, address, quantity, or ID number of manifest on list.  | \$300    | 7:26-7.5(d)8vi    | Failure of non-rail hauler accepting hazardous waste from rail hauler to return signed copy of manifest to rail hauler.   | \$500    |
| 7:26-7.5(b)3iii | Failure of hauler to attach list to copy of manifest and forward to the Department.  | \$1,000  | 7:26-7.5(d)9      | Failure of hauler transporting waste out of U.S. to indicate date waste left U.S.   | \$2,000  |
| 7:26-7.5(b)3iv  | Failure of hauler to obtain a signed receipt from each site at which he accepts X-700 series hazardous waste.  | \$1,000  | 7:26-7.5(d)10     | Failure of hauler to deliver entire quantity to designated facility, next designated hauler or place outside U.S.   | \$5,000  |
| 7:26-7.5(c)1    | Failure of hauler to obtain hazardous waste hauler license prior to operation.   | \$10,000 | 7:26-7.5(d)11     | Failure of hauler to contact generator for instructions and to revise manifest in case of undeliverable shipment.   | \$2,000  |
| 7:26-7.5(c)5    | Failure of hauler to update license information prior to October 1 of each year.   | \$500    | 7:26-7.5(d)12     | Failure of hauler to provide complete program of instruction for hauler employees.  | \$2,000  |
| 7:26-7.5(c)6    | Failure of hauler to notify Department of change of information on license.  | \$500    | 7:26-7.5(d)13     | Failure of hauler to comply with 49 CFR 391.  | \$2,000  |
| 7:26-7.5(d)1    | Failure of hauler transporting hazardous wastes to have EPA identification number.   | \$1,000  | 7:26-7.5(d)14     | Failure of hauler to operate their vehicles in conformance with 49 CFR 392.   | \$2,000  |
| 7:26-7.5(d)2    | Hauler accepting hazardous waste from a generator when it is not accompanied by a properly completed manifest.   | \$1,000  | 7:26-7.5(d)15     | Failure of hauler to equip vehicle with emergency equipment in conformance with 49 CFR 393.   | \$500    |
| 7:26-7.5(d)3    | Hauler accepting improperly labeled hazardous waste.   | \$1,000  | 7:26-7.5(d)16     | Failure of haulers to transport hazardous waste in accordance with 49 CFR 397.  | \$1,000  |
| 7:26-7.5(d)3    | Hauler accepting hazardous waste that does not reasonably fit the description of the manifest.   | \$3,000  | 7:26-7.5(d)17     | Failure of hauler to prevent registered vehicle from being used by another hauler not properly licensed by the Department.  | \$10,000 |
| 7:26-7.5(d)4    | Failure of hauler to sign or date manifest.  | \$2,000  | 7:26-7.5(d)18     | Failure of hauler to have in possession a list of agencies to notify in event of discharge.   | \$500    |
| 7:26-7.5(d)4    | Failure of hauler to return a signed copy of manifest to generator before transporting.  | \$500    | 7:26-7.5(d)19     | Failure of hauler to display registration decal.  | \$1,000  |
| 7:26-7.5(d)5    | Failure of hauler to ensure that manifest accompanies hazardous waste.   | \$10,000 | 7:26-7.5(e)       | Failure of hauler to allow the Department to enter and inspect any vehicle.   | \$5,000  |
| 7:26-7.5(d)6i   | Failure of hauler to obtain date of delivery and handwritten signature of other hauler or of owner or operator of designated facility.                   | \$2,000  |                   |   |          |
| 7:26-7.5(d)6ii  | Failure of hauler to retain copy of manifest.  | \$1,000  |                   |   |          |
| 7:26-7.5(d)6iii | Failure of hauler to give remaining copies of manifest to the accepting hauler or designated facility.   | \$1,000  |                   |   |          |

**PROPOSALS**

**Interested Persons see Inside Front Cover**

**ENVIRONMENTAL PROTECTION**

|                 |   |          |   |   |          |
|-----------------|---|----------|---|---|----------|
| 7:26-7.5(f)1i   | Failure of hauler to immediately notify the Department and the generator concerning an unauthorized discharge of hazardous waste during transportation.                         | \$5,000  | 7:26-7.6(b)3  | Failure of facility owner or operator to give hauler a copy of manifest.  | \$1,000  |
| 7:26-7.5(f)1ii  | Failure of hauler to take appropriate immediate action to protect human health and environment from a discharge of hazardous waste during transportation.                       | \$10,000 | 7:26-7.6(b)4  | Failure of facility owner or operator to send copy of manifest to generator within thirty days after delivery of hazardous waste.   | \$1,000  |
| 7:26-7.5(f)1iii | Failure of hauler to take any action required by N.J.A.C. 7:1E-2.3.   | \$10,000 | 7:26-7.6(b)5  | Failure of facility owner or operator to forward copy of manifest to Department or to generator's State agency by next business day.  | \$1,000  |
| 7:26-7.5(f)1iv  | Failure of hauler to clean up the discharge and take action as may be required or approved.   | \$10,000 | 7:26-7.6(b)6  | Failure of facility owner or operator to retain copy of manifest for three years.   | \$1,000  |
| 7:26-7.5(f)3    | Failure by air, rail, highway or water hauler having a discharge to comply with State and federal notice and report requirements.   | \$3,000  | 7:26-7.6(c)   | Importing hazardous waste from a foreign country without notifying the Department or the EPA at least four weeks in advance of expected delivery.   | \$10,000 |
| 7:26-7.5(g)1    | Failure of hauler to properly complete manifest.  | \$2,000  | 7:26-7.6(d)1  | Failure of facility owner or operator receiving hazardous waste from rail or water (bulk shipment) hauler to sign or date manifest or shipping paper.   | \$2,000  |
| 7:26-7.5(g)2    | Hauler accepting hazardous waste from generator who failed to properly complete manifest.   | \$2,000  | 7:26-7.6(d)2  | Failure of facility owner or operator receiving hazardous waste from rail or water (bulk shipment) hauler to note any significant discrepancies in manifest or shipping paper on each copy of manifest or shipping paper. | \$1,000  |
| 7:26-7.5(g)3    | Hauler transporting hazardous waste to unauthorized facility.   | \$5,000  | 7:26-7.6(d)3  | Failure of facility owner or operator receiving hazardous waste from rail or water (bulk shipment) hauler to give hauler a copy of manifest or shipping paper.  | \$1,000  |
| 7:26-7.5(h)1    | Failure of hauler to maintain signed copy of manifest for three years.  | \$1,000  | 7:26-7.6(d)4  | Failure of facility owner or operator receiving hazardous waste from rail or water (bulk shipment) hauler to send copy of manifest or shipping paper to generator within thirty days after delivery.                      | \$1,000  |
| 7:26-7.5(h)2    | Failure of water bulk shipment hauler to maintain copy of shipping paper for three years.   | \$1,000  | 7:26-7.6(d)5  | Failure of facility owner or operator receiving hazardous waste from rail or water (bulk shipment) hauler to retain copy of manifest for three years.   | \$1,000  |
| 7:26-7.5(h)3    | Failure of rail hauler to maintain copy of manifest and shipping paper for three years.   | \$1,000  | 7:26-7.6(e)1  | Facility operator accepting waste other than that authorized by Department.   | \$25,000 |
| 7:26-7.5(h)5    | Failure of hauler to maintain copy of manifest and date shipment left U.S. for three years.   | \$1,000  | 7:26-7.6(e)2  | Facility operator accepting waste from an unauthorized hauler.  | \$5,000  |
| 7:26-7.5(h)6    | Failure of hauler to maintain copy of manifest during the course of unresolved enforcement action or as requested by the Department.  | \$1,000  | 7:26-7.6(e)3  | Facility operator accepting waste from a hauler failing to display Department registration number.  | \$500    |
| 7:26-7.5(i)     | Failure by hauler to submit annual report of transportation activities by May 1 of each year.   | \$1,000  | 7:26-7.6(f)1  | Failure of facility owner or operator to maintain daily operating record.   | \$1,000  |
| 7:26-7.6(a)1    | Failure of facility owner or operator to obtain EPA identification number.  | \$5,000  | 7:26-7.6(f)2  | Failure of facility owner or operator to prepare and submit two copies of an annual report by March 1 of each year or failure of report to meet requirements.   | \$1,000  |
| 7:26-7.6(a)2    | Failure of facility operator to accept waste only if properly labeled and marked.   | \$2,000  | 7:26-7.7(d)   | Generator exempt pursuant to N.J.A.C. 7:26-7.7(b) or (c) offering hazardous waste to unregistered hauler.   | \$3,000  |
| 7:26-7.6(a)2    | Facility operator accepting hazardous waste not accompanied by properly completed manifest.   | \$10,000 | 7:26-7.7(d)   | Failure of generator exempt pursuant to N.J.A.C. 7:26-7.7(b) or (c) to obtain written receipt from hauler or to retain receipt on file for three years.   | \$500    |
| 7:26-7.6(a)3    | Failure of facility operator when accepting waste other than that described in manifest to notify Department of discrepancy within one week.                                    | \$1,000  | 8. The violations of N.J.A.C. 7:26-8, Hazardous Waste Criteria, Identification and Listing, and the civil administrative penalty amounts for each violation, are as set forth in the following table. |   |          |
| 7:26-7.6(a)4    | Failure of facility operator when, after acceptance, waste is other than described, to reconcile discrepancy with generator or hauler, or to notify Department within one week. | \$1,000  |   |   |          |
| 7:26-7.6(a)5    | Failure of facility to obtain written generator approval or to execute manifests before shipping waste to another facility.   | \$10,000 |   |   |          |
| 7:26-7.6(b)1    | Failure of facility owner or operator to sign or date manifest.   | \$2,000  |   |   |          |
| 7:26-7.6(b)2    | Failure of facility owner or operator to note any significant discrepancies in the manifest on each copy of the manifest.   | \$1,000  |   |   |          |

**ENVIRONMENTAL PROTECTION**

**PROPOSALS**

| RULE  | RULE SUMMARY   | BASE PENALTY |                 |   |          |
|---|--|--------------|-----------------|---|----------|
| N.J.A.C. 7:26-8.5(a)  | Failure of generator of solid waste to determine if waste is hazardous.  | \$10,000     | 7:26-9.3(d)3    | Failure of generator accumulating hazardous waste on-site without a permit to have accumulation area at or near any point of generation where wastes initially accumulate in a process.   | \$1,000  |
| 7:26-8.5(c)   | Failure of generator, on request by Department, to submit plan for analyzing the waste to detect presence of hazardous waste constituents listed in N.J.A.C. 7:26-8.16.  | \$10,000     | 7:26-9.3(d)4    | Failure of generator to mark container with the words "HAZARDOUS WASTE".  | \$1,000  |
| 7:26-8.5(d)   | Failure of generator to keep records of any test results, analysis or other determinations for three years.  | \$2,000      | 7:26-9.3(d)5    | Failure of generator to mark container with the date the quantity reaches the volume indicated in N.J.A.C. 7:26-9.3(d)1.  | \$1,000  |
| <p>9. The violations of N.J.A.C. 7:26-9, Requirements for Hazardous Waste Facilities, and the civil administrative penalty amounts for each violation, are as set forth in the following table.</p> |  |              |                 |   |          |
| RULE  | RULE SUMMARY   | BASE PENALTY |                 |   |          |
| N.J.A.C. 7:26-9.2(a)2   | Handling hazardous waste in a manner that causes or may cause an unauthorized discharge of pollutants.   | \$5,000      | 7:26-9.4(a)1    | Failure of a facility owner or operator who receives a new hazardous waste stream from an off site source to notify generator in writing, of permit, and acceptance of new waste stream.  | \$2,000  |
| 7:26-9.2(b)1  | Installation or use of new underground storage tanks containing hazardous waste.   | \$10,000     | 7:26-9.4(a)3    | Failure of facility owner or operator to notify the Department or comply with each requirement of N.J.A.C. 7:26-9.1(c)13 before accepting an off-site waste stream for waste reuse.   | \$2,000  |
| 7:26-9.2(b)2  | Conversion of underground storage tanks in use or ready for use for storage of hazardous waste.  | \$10,000     | 7:26-9.4(b)1i   | Failure of facility owner or operator to obtain detailed chemical analysis of representative sample before treating, storing or disposing of any hazardous waste.   | \$10,000 |
| 7:26-9.2(b)3  | Use of existing underground storage tanks for hazardous waste without monitoring pursuant to N.J.A.C. 7:14A-6 or not within time limitation or without managing pursuant to N.J.A.C. 7:26-10.5(e)6.                    | \$10,000     | 7:26-9.4(b)1iii | Failure of facility owner or operator to repeat analysis as necessary to ensure that it is accurate and up to date.   | \$5,000  |
| 7:26-9.2(b)4  | Use of hazardous waste piles.  | \$25,000     | 7:26-9.4(b)1v   | Failure of owner or operator of an off site facility to inspect each hazardous waste shipment received or analyze to determine whether it matches the identity of the waste specified on the accompanying manifest or shipping paper. | \$3,000  |
| 7:26-9.2(c)   | Discharging of hazardous waste into a sewer system without approval or not in conformance with such approval.  | \$25,000     | 7:26-9.4(b)2    | Failure of facility owner or operator to develop or follow a written waste analysis plan, or to comply with each of the requirements of N.J.A.C. 7:26-9.4(b)2.  | \$5,000  |
| 7:26-9.2(d)   | Final land disposal of acute hazardous waste or toxic waste not exempted by N.J.A.C. 7:26-9.2(d)1 and 2.   | \$50,000     | 7:26-9.4(b)3ii  | Failure of facility owner or operator to conform waste analysis with provisions of proposed plan pending final approval by Department.  | \$5,000  |
| 7:26-9.3(a)1  | Failure of generator to ship waste off site within 90 days or to place it in an on-site authorized facility.   | \$2,000      | 7:26-9.4(c)1    | Facility owner or operator accepting waste it is not authorized to handle.  | \$25,000 |
| 7:26-9.3(a)2  | Failure of generator to place waste in containers that meet required standards or are properly managed.  | \$2,000      | 7:26-9.4(c)2    | Failure of facility owner or operator to follow each of the requirements of N.J.A.C. 7:26-9.4(c)2 if offered waste of a type it is not authorized to handle.  | \$1,000  |
| 7:26-9.3(a)3  | Failure of generator to clearly mark container with date when accumulation period begins or to make mark visible for inspection.   | \$5,000      | 7:26-9.4(d)1i   | Facility owner or operator storing hazardous waste in inadequate container.   | \$2,000  |
| 7:26-9.3(b)   | Failure of generator accumulating hazardous waste in above ground tanks for 90 days or less without receiving Department approval, to comply with each requirement of N.J.A.C. 7:26-9.3(b)1 through 9.                 | \$2,000      | 7:26-9.4(d)2    | Failure of facility owner or operator to handle hazardous waste as required by N.J.A.C. 7:26-9.4(d)2.   | \$2,000  |
| 7:26-9.3(d)1  | Failure of generator accumulating hazardous waste on-site without a permit to ensure that quantity of waste in each area is less than 55 gallons of hazardous waste or less than one quart of acutely hazardous waste. | \$1,000      | 7:26-9.4(d)3    | Failure of facility owner or operator to use container compatible with hazardous waste stored.  | \$2,000  |
| 7:26-9.3(d)2  | Failure of generator accumulating hazardous waste on-site without a permit to place waste in containers meeting standards of N.J.A.C. 7:26-7.2 or to appropriately manage containers.                                  | \$1,000      | 7:26-9.4(d)4    | Failure of facility owner or operator to comply with any of the requirements for management of containers.  | \$1,000  |

**PROPOSALS**

**Interested Persons see Inside Front Cover**

**ENVIRONMENTAL PROTECTION**

|                 |  |          |              |   |          |
|-----------------|--|----------|--------------|---|----------|
| 7:26-9.4(d)5    | Failure of facility owner or operator to perform daily inspection of each area where containers are stored.  | \$1,000  | 7:26-9.4(k)1 | Failure of facility owner or operator to furnish upon request, or make available for inspection, any record.  | \$5,000  |
| 7:26-9.4(d)6    | Failure of facility owner or operator to store containers holding ignitable or reactive wastes at least 50 feet from property line.  | \$2,000  | 7:26-9.4(k)2 | Failure of facility owner or operator to keep any record during course of any unresolved enforcement action or as requested by the Department.  | \$2,000  |
| 7:26-9.4(d)7    | Failure of facility owner or operator to comply with each of the special requirements for incompatible wastes.   | \$2,000  | 7:26-9.4(k)3 | Failure of facility owner or operator to submit copy of waste disposal locations or quantities to Department or local land authority upon closure of facility.  | \$25,000 |
| 7:26-9.4(e)1i   | Failure of facility owner or operator to keep ignitable, reactive or incompatible wastes separated and protected from sources of ignition or reaction.   | \$5,000  | 7:26-9.4(l)  | Failure of facility owner or operator to provide, when requested, work space at the facility for a Department inspector and equipment overseeing monitors and analysis.   | \$1,000  |
| 7:26-9.4(e)1ii  | Failure of facility owner or operator to confine smoking or open flame to specially designated locations while handling ignitable or reactive waste.   | \$2,000  | 7:26-9.4(n)  | Failure of facility owner or operator to post a warning sign provided by the Department in work areas.  | \$1,000  |
| 7:26-9.4(e)1iii | Failure of facility owner or operator to conspicuously place "No Smoking" signs wherever there is a hazard from ignitable or reactive waste.   | \$500    | 7:26-9.5     | Failure of facility owner or operator to provide facility with ground water monitoring system in accordance with N.J.A.C. 7:14A-6.  | \$50,000 |
| 7:26-9.4(e)2    | Failure of the facility owner or operator to treat, store, or dispose of ignitable, reactive or mixtures of incompatible wastes in accordance with each of the requirements of N.J.A.C. 7:26-9.4(e)2i through v. | \$2,000  | 7:26-9.6(a)  | Failure of facility owner or operator to design, construct, maintain or operate facility to minimize possibilities of fire, explosion or releases of hazardous waste or hazardous waste constituents.   | \$5,000  |
| 7:26-9.4(f)1    | Failure of facility owner or operator to inspect for malfunctions, deterioration, errors or discharges.  | \$2,000  | 7:26-9.6(b)  | Failure of facility owner or operator to equip facility with emergency equipment.   | \$10,000 |
| 7:26-9.4(f)2    | Failure of facility owner or operator to perform frequent inspections pursuant to N.J.A.C. 7:26-9.4(f)2.   | \$2,000  | 7:26-9.6(c)  | Failure of facility owner or operator to test and maintain emergency equipment.   | \$5,000  |
| 7:26-9.4(f)3    | Failure of facility owner or operator to develop or follow written schedule for inspecting monitoring, safety, emergency, security equipment, etc.   | \$2,000  | 7:26-9.6(d)  | Failure of facility owner or operator to maintain access to communications or alarm system.   | \$5,000  |
| 7:26-9.4(f)4    | Failure of facility owner or operator to follow proposed schedule for inspecting monitoring equipment pending Department approval.   | \$2,000  | 7:26-9.6(e)  | Failure of facility owner or operator to maintain sufficient aisle space for the unobstructed movement of personnel or equipment in an emergency.   | \$2,000  |
| 7:26-9.4(f)5    | Failure of facility owner or operator to remedy any deterioration or malfunction immediately or on an appropriate schedule.  | \$5,000  | 7:26-9.6(f)  | Failure of facility owner or operator to make required arrangements with police or fire departments, emergency response contractors, equipment suppliers, or local hospitals, or to document any such authority's refusal of such arrangements. | \$5,000  |
| 7:26-9.4(f)6    | Failure of facility owner or operator to record inspections in log or to retain required information for three years.  | \$2,000  | 7:26-9.7(a)  | Failure of facility owner or operator to have contingency plan designed to minimize hazards to human health and environment.  | \$10,000 |
| 7:26-9.4(g)     | Failure of facility owner or operator to provide required classroom or on-the-job training for facility personnel.   | \$2,000  | 7:26-9.7(b)  | Failure of facility owner or operator to carry out provisions of the plan immediately if there is a fire, explosion or release.   | \$25,000 |
| 7:26-9.4(h)1    | Failure of facility owner or operator to have adequate surveillance system, or adequate artificial or natural barrier or means to control entry.   | \$25,000 | 7:26-9.7(c)  | Failure of contingency plan to describe actions to be taken to comply with N.J.A.C. 7:26-9.7(a), (b), or (e).   | \$5,000  |
| 7:26-9.4(h)3    | Failure of facility owner or operator to post signs meeting each requirement of N.J.A.C. 7:26-9.4(h)3.   | \$2,000  | 7:26-9.7(d)  | If facility has SPCC (40 CFR 112 or 151) or DPCC (N.J.A.C. 7:1E) plan, failure of facility owner or operator to amend that plan to incorporate hazardous waste management provisions.   | \$5,000  |
| 7:26-9.4(i)     | Failure of facility owner or operator to keep written operating records meeting each requirement of N.J.A.C. 7:26-9.4(i)1 through 9.   | \$2,000  | 7:26-9.7(e)  | Failure of contingency plan to describe arrangements agreed to by local police or fire departments, hospitals, contractors, or State or local emergency response teams.   | \$1,000  |
| 7:26-9.4(j)     | Failure of facility owner or operator to prepare or submit two copies of annual report to Department by March 1 in accordance with N.J.A.C. 7:26-7.6(f)2.  | \$1,000  |              |   |          |

**ENVIRONMENTAL PROTECTION**

**PROPOSALS**

|              |  |          |               |  |          |
|--------------|--|----------|---------------|--|----------|
| 7:26-9.7(f)  | Failure of contingency plan to list name, addresses or phone numbers of persons qualified to act as emergency coordinator.   | \$2,000  | 7:26-9.8(c)   | Failure of facility owner or operator to have written closure plan with plan.  | \$25,000 |
| 7:26-9.7(g)  | Failure of contingency plan to list emergency equipment, updated as required, with its location, description, or capabilities specified.   | \$2,000  | 7:26-9.8(c)   | Failure of facility owner or operator to keep copy of closure plan, or any revisions, at the facility.   | \$1,000  |
| 7:26-9.7(h)  | Failure of contingency plan to include evacuation procedure for personnel including signals, evacuation routes or alternate evacuation routes.   | \$2,000  | 7:26-9.8(f)   | Failure of facility owner or operator to amend or request modification of closure plan within 60 days of change.   | \$2,000  |
| 7:26-9.7(i)  | Failure of contingency plan to be maintained at facility with a copy sent to local police or fire departments, hospitals or State or local emergency response teams.   | \$2,000  | 7:26-9.8(g)   | Failure of facility owner or operator to notify DEP 180 days prior to anticipated commencement of closure.   | \$10,000 |
| 7:26-9.7(j)  | Failure of facility owner or operator to review or amend contingency plan as necessary.  | \$2,000  | 7:26-9.8(h)l  | Failure of facility owner or operator to submit closure plan pursuant to the provisions of N.J.A.C. 7:26-9.8(h).   | \$10,000 |
| 7:26-9.7(k)  | Failure of facility owner or operator to make emergency coordinator thoroughly familiar with plan or available at all times.   | \$5,000  | 7:26-9.8(i)   | Failure of facility owner or operator to treat, remove or dispose of waste within 90 days after final volume of wastes received or closure plan approved.                    | \$10,000 |
| 7:26-9.7(l)1 | Failure of emergency coordinator to identify character, source, amount or areal extent of discharged materials, or to activate alarms or communications systems, or to notify appropriate State or local agencies if necessary.  | \$5,000  | 7:26-9.8(j)   | Failure of facility owner or operator to complete closure within 180 days after final volume of wastes received or closure plan approved.                                    | \$10,000 |
| 7:26-9.7(l)2 | Failure of emergency coordinator to assess possible hazards to human health and environment.   | \$5,000  | 7:26-9.8(k)   | Failure of facility owner or operator, when closure is complete, to have disposed of or decontaminated all facility equipment or structures.                                 | \$10,000 |
| 7:26-9.7(l)3 | Failure of emergency coordinator to notify appropriate emergency response agency in situation threatening health and environment.  | \$5,000  | 7:26-9.8(l)   | Failure of facility owner or operator, when closure completed, to submit its own certification or that of an independent registered professional engineer to the Department. | \$10,000 |
| 7:26-9.7(l)4 | Failure of emergency coordinator to take reasonable measures to ensure hazards are minimized.  | \$5,000  | 7:26-9.9(b)   | Failure of facility owner or operator to continue proper post-closure care for 30 years and to comply with N.J.A.C. 7:26-9.9(b).   | \$10,000 |
| 7:26-9.7(l)5 | Failure of the emergency coordinator to monitor leaks, pressure buildup, gas generation, or ruptures, if the facility stopped operating due to fire, explosion or discharge.   | \$5,000  | 7:26-9.9(e)   | Failure of facility owner or operator to ensure that post-closure activity does not disturb final cover, liner(s), or containment or monitoring system.                      | \$10,000 |
| 7:26-9.7(l)6 | Failure of emergency coordinator to provide for treating, storing, or disposing of recovered waste, contaminated soil or surface water, or other material.   | \$5,000  | 7:26-9.9(f)   | Failure of facility owner or operator to perform post-closure care activities in accordance with post-closure plan.  | \$10,000 |
| 7:26-9.7(l)7 | Failure of emergency coordinator to insure that in affected area of facility no incompatible waste is treated, stored or disposed of until cleanup procedures are complete, or to insure that emergency equipment is cleaned and fit for intended use before operations are resumed. | \$5,000  | 7:26-9.9(g)   | Failure of facility owner or operator to have written post-closure plan.   | \$10,000 |
| 7:26-9.7(l)8 | Failure of facility owner or operator to notify DEP and local authorities that facility is in compliance before operations are resumed.  | \$5,000  | 7:26-9.9(g)   | Failure of facility owner or operator to keep copy of post-closure plan, or any revisions, at the facility.  | \$1,000  |
| 7:26-9.7(l)9 | Failure of facility owner or operator to submit incident report to DEP within 15 days after the incident.  | \$2,000  | 7:26-9.9(j)   | Failure of facility owner or operator to amend or request modification of post-closure plan when necessary.  | \$2,000  |
| 7:26-9.8(b)  | Failure of facility owner or operator to close in a manner that minimizes further maintenance and controls to the extent necessary to protect human health and environment.  | \$50,000 | 7:26-9.9(k)   | Failure of facility owner or operator to submit post-closure plan 180 days in advance of closure and pursuant to N.J.A.C. 7:26-9.9(k).                                       | \$10,000 |
|              |  |          | 7:26-9.9(m)   | Failure of facility owner or operator, within 90 days after closure, to submit to local authorities and DEP detailed information on site.                                    | \$25,000 |
|              |  |          | 7:26-9.9(n)   | Failure of facility owner or operator to comply with requirements for notice in deed to property.  | \$5,000  |
|              |  |          | 7:26-9.10(e)l | Failure of facility owner or operator to have a written estimate of the cost of closing facility.  | \$5,000  |

**PROPOSALS**

**Interested Persons see Inside Front Cover**

**ENVIRONMENTAL PROTECTION**

|               |   |          |                  |  |          |
|---------------|---|----------|------------------|--|----------|
| 7:26-9.10(e)2 | Failure of facility owner or operator to adjust closure cost estimate for inflation within 30 days after each anniversary of the preparation of the first closure cost estimate.                        | \$5,000  | 7:26-10.4(b)liii | Failure of container storage area to be sloped or designed and operated to drain efficiently, and for containers to be protected from contact with accumulated liquids.  | \$5,000  |
| 7:26-9.10(e)3 | Failure of facility owner or operator to revise the closure cost estimate whenever a change in the closure plan increases the cost of closure.  | \$5,000  | 7:26-10.4(b)liv  | Failure of container storage area to have capacity to contain 10 percent of volume of all containers or volume of largest container whichever is greater and additional capacity for rainwater.  | \$10,000 |
| 7:26-9.10(e)4 | Failure of facility owner or operator to keep the latest closure cost estimate and adjusted closure cost estimate at the facility.  | \$5,000  | 7:26-10.4(b)2    | Failure of container storage area to be protected from run-on, unless this requirement is waived.  | \$5,000  |
| 7:26-9.10(f)  | Failure of facility owner or operator to establish financial assurance for closure of facility.   | \$10,000 | 7:26-10.4(b)3    | Failure of facility owner or operator to protect container storage area by removing accumulated precipitation from sump or collection area in a timely manner to prevent blockage or overflow.   | \$3,000  |
| 7:26-9.11(c)1 | Failure of facility owner or operator to have a written estimate of the cost of post-closure care.  | \$5,000  | 7:26-10.4(b)4    | Failure of facility owner or operator to remove spilled or leaked waste daily from sump or collection area.  | \$5,000  |
| 7:26-9.11(c)2 | Failure of facility owner or operator to adjust cost estimate of post-closure care for inflation within 30 days after each anniversary of the preparation of the first post-closure care cost estimate. | \$5,000  | 7:26-10.4(c)1    | Failure of facility owner or operator to remove all hazardous wastes and residues from containment system at closure or failure to remove or decontaminate remaining containers, liners, bases and soil containing or contaminated with hazardous waste. | \$10,000 |
| 7:26-9.11(c)3 | Failure of facility owner or operator to revise the post-closure care cost estimate whenever a change in the post-closure plan increases the cost of post-closure care.                                 | \$5,000  | 7:26-10.4(c)2    | Failure of facility owner or operator at closure, to treat waste as a hazardous waste unless proven to be non-hazardous.   | \$10,000 |
| 7:26-9.11(c)4 | Failure of facility owner or operator to keep the latest post-closure care cost estimate at the facility.   | \$1,000  | 7:26-10.5(b)1    | Failure of tanks to have sufficient strength or to meet other specified requirements.  | \$10,000 |
| 7:26-9.11(d)  | Failure of facility owner or operator to establish financial assurance for post-closure care of facility.   | \$10,000 | 7:26-10.5(b)2    | Failure of facility owner or operator to have shell thickness reports at facility for life of the tank.  | \$1,000  |
| 7:26-9.13(a)  | Failure of facility owner or operator to meet liability requirements for sudden accidental occurrences.   | \$10,000 | 7:26-10.5(c)1    | Facility owner or operator placing waste or other material in tank incompatible with such material.  | \$10,000 |
| 7:26-9.13(b)  | Failure of facility owner or operator to meet the liability requirements for nonsudden occurrences.   | \$10,000 | 7:26-10.5(c)2i   | Failure of tank to have controls to prevent overfilling.   | \$2,000  |
| 7:26-9.14(a)  | Failure of facility owner or operator or guarantor to notify Department of commencement of proceeding under Title 11 of the Bankruptcy Code.  | \$25,000 | 7:26-10.5(c)2ii  | Failure of facility owner or operator to maintain sufficient freeboard for uncovered tanks to prevent overtopping by wave or wind action or precipitation.   | \$2,000  |
| 7:26-9.14(b)  | Failure of facility owner or operator to establish other financial assurances or liability coverage pursuant to N.J.A.C. 7:26-9.14(b).  | \$10,000 | 7:26-10.5(d)1    | Failure of above-ground tank storage areas to have a containment system capable of collecting and holding spills, leaks and precipitation.   | \$10,000 |

10. The violations of N.J.A.C. 7:26-10, Additional Operational and Design Standards for Hazardous Waste Facilities, and the civil administrative penalty amounts for each violation, are as set forth in the following table.

| RULE            | RULE SUMMARY   | BASE PENALTY |                  |   |          |
|-----------------|--|--------------|------------------|---|----------|
| N.J.A.C.        |  |              | 7:26-10.5(d)li   | Failure of above-ground tank storage area to have an underlying base free of cracks or gaps, or to be sufficiently impervious.  | \$5,000  |
| 7:26-10.4(b)1   | Failure of container storage area to have a containment system capable of collecting and holding spills, leaks and precipitation.  | \$5,000      | 7:26-10.5(d)lii  | Failure of containment system to consist of material compatible with material stored.   | \$10,000 |
| 7:26-10.4(b)1i  | Failure of container storage area to have an underlying base free of cracks or gaps; sufficiently impervious with permeability rating no greater than 10 <sup>-7</sup> cm/sec. | \$5,000      | 7:26-10.5(d)liii | Failure of containment system to be sloped or designed and operated to drain efficiently or to have tanks protected from contact with accumulated liquids.                          | \$5,000  |
| 7:26-10.4(b)1ii | Failure of container storage area to consist of material compatible with material stored.  | \$5,000      | 7:26-10.5(d)liv  | Failure of containment system to have capacity to contain 10 percent of volume of all tanks or volume of largest tank, whichever is greater, and additional capacity for rainwater. | \$10,000 |

**ENVIRONMENTAL PROTECTION**

**PROPOSALS**

|                  |  |          |                  |   |          |
|------------------|--|----------|------------------|---|----------|
| 7:26-10.5(d)2    | Failure of facility owner or operator to prevent run-on into containment system unless requirement waived.   | \$5,000  | 7:26-10.6(a)3    | Failure of facility owner or operator to design and operate surface impoundments used as TSDs in such a way as to prevent discharges.   | \$50,000 |
| 7:26-10.5(d)3    | Failure of facility owner or operator to remove accumulated precipitation from sump or collection area in a timely manner.   | \$3,000  | 7:26-10.6(a)4    | Failure of facility owner or operator to obtain permit pursuant to N.J.A.C. 7:14A for surface impoundments.   | \$25,000 |
| 7:26-10.5(d)4    | Failure of facility owner or operator to remove spilled or leaked waste daily from sump or collection area.  | \$5,000  | 7:26-10.6(b)     | Failure of surface impoundment used as TSD to have liner system that prevents migration of waste during active life of impoundment.   | \$50,000 |
| 7:26-10.5(e)i    | Failure of facility owner or operator to inspect overfilling control equipment each operating day.   | \$1,000  | 7:26-10.6(b)1i   | Failure of surface impoundment to have two liners installed to cover all surrounding earth likely to be in contact with the waste or leachate.                                    | \$50,000 |
| 7:26-10.5(e)lii  | Failure of facility owner or operator to inspect data gathered from monitoring equipment each operating day.   | \$1,000  | 7:26-10.6(b)1ii  | Failure of primary liner synthetic material to be at least 30 mils thick to prevent flow of liquid through liner during active life of facility.                                  | \$25,000 |
| 7:26-10.5(e)liii | Failure of facility owner or operator to monitor monitoring equipment continuously during use if no automatic alarm.   | \$1,000  | 7:26-10.6(b)1iii | Failure of secondary liner to consist of at least three feet of soil or synthetic material at least 30 mils thick to prevent liquid from flowing through during life of facility. | \$25,000 |
| 7:26-10.5(e)liv  | Failure of facility owner or operator to inspect level of waste in uncovered tanks each operating day.   | \$1,000  | 7:26-10.6(b)1iv  | Failure of facility owner or operator to place lower liner on foundation capable of providing support.  | \$50,000 |
| 7:26-10.5(e)lv   | Failure of facility owner or operator to inspect construction materials of above-ground portions of a tank for erosion or corrosion and leaking of pipes, seams or fixtures.                       | \$2,000  | 7:26-10.6(b)1v   | Failure of each liner to be suitable for purpose intended and compatible with waste placed in impoundment.  | \$50,000 |
| 7:26-10.5(e)lvi  | Failure of facility owner or operator to inspect area immediately surrounding tank for signs of leakage.   | \$1,000  | 7:26-10.6(b)1vi  | Failure of liner to have properties that prevent failure due to pressure head, contact with the waste, climatic conditions, and stress of installation.                           | \$50,000 |
| 7:26-10.5(e)2    | Failure of facility owner or operator to develop and implement schedule and procedure for assessing condition of tank.   | \$1,000  | 7:26-10.6(b)1vii | Failure of bottom surface of secondary liner to be no less than five feet above seasonally high water table.  | \$50,000 |
| 7:26-10.5(e)3    | Failure of facility owner or operator to specify procedures to respond to tank spills or leakage as part of contingency plan.  | \$2,000  | 7:26-10.6(b)1ix  | Failure of surface impoundment to have secondary collection system between primary and secondary liner.   | \$50,000 |
| 7:26-10.5(e)4    | Failure of facility owner or operator to remedy any leak, crack or wall thinning or any equipment or process malfunction discovered during inspection.   | \$5,000  | 7:26-10.6(b)1x   | Failure of facility owner or operator to obtain certification of system by licensed engineer.   | \$10,000 |
| 7:26-10.5(e)5    | Failure of facility owner or operator to subject above ground tank to periodic integrity testing on appropriate schedule.  | \$1,000  | 7:26-10.6(c)1    | Failure of surface impoundment to be designed and constructed to prevent discharge during active life.  | \$10,000 |
| 7:26-10.5(e)6    | Failure of facility owner or operator to subject underground tank to periodic integrity testing.   | \$2,000  | 7:26-10.6(c)2    | Failure of surface impoundment to be designed and constructed to prevent overtopping and to provide at least 60 centimeters of freeboard.   | \$5,000  |
| 7:26-10.5(h)1    | Failure of facility owner or operator at closure to remove all hazardous wastes and residues from tanks, discharge control equipment, discharge confinement structures and the containment system. | \$10,000 | 7:26-10.6(c)3    | Failure of surface impoundment to be designed with dikes.   | \$5,000  |
| 7:26-10.5(i)1    | Failure of facility owner or operator to meet specific requirements before placing ignitable or reactive waste in a tank.  | \$5,000  | 7:26-10.6(c)4    | Failure of earthen dikes to have protective covers.   | \$5,000  |
| 7:26-10.5(i)2    | Failure of facility owner or operator treating or storing ignitable or reactive wastes in covered tanks to comply with NFPA's buffer zone requirements for tanks.                                  | \$5,000  | 7:26-10.6(c)5    | Failure of surface impoundments to be designed in such a way that flow of waste into impoundment can be immediately shut off.   | \$25,000 |
| 7:26-10.5(j)1    | Failure of facility owner or operator to prevent placing incompatible wastes in the same tank.   | \$5,000  | 7:26-10.6(c)6    | Failure of surface impoundments to be designed with a run-on control system.  | \$5,000  |
| 7:26-10.5(j)2    | Failure of facility owner or operator to prevent the placing of hazardous waste in an unwashed tank which previously held incompatible waste.  | \$5,000  | 7:26-10.6(c)7    | Failure of facility owner or operator to obtain certification of system by licensed engineer.   | \$10,000 |
|                  |  |          | 7:26-10.6(d)     | Failure of owner or operator of surface impoundment to implement a groundwater monitoring system.   | \$10,000 |

**PROPOSALS**

**Interested Persons see Inside Front Cover**

**ENVIRONMENTAL PROTECTION**

|                |   |          |                  |  |          |
|----------------|---|----------|------------------|--|----------|
| 7:26-10.6(e)1  | Failure to maintain and operate surface impoundments to prevent overtopping, so as to comply with N.J.A.C. 7:26-10.6(c)2.                                   | \$5,000  | 7:26-10.6(g)6    | Failure of facility owner or operator to close surface impoundment that is not being put back into service in accordance with (h)1 through 6.  | \$25,000 |
| 7:26-10.6(e)2  | Failure to operate surface impoundment with at least 60 centimeters of freeboard.   | \$5,000  | 7:26-10.7(b)2    | Failure of facility owner or operator, throughout normal operation of incinerator, to conduct sufficient waste analyses to verify compliance with permit.                                    | \$5,000  |
| 7:26-10.6(e)3  | Failure to maintain and operate earthen dikes in accordance with N.J.A.C. 7:26-10.6(c)3 or to keep free of burrowing animals.                               | \$5,000  | 7:26-10.7(f)1    | Failure of facility owner or operator to operate incinerator in accordance with operating requirements of permit.  | \$5,000  |
| 7:26-10.6(e)4  | Failure to divert run-on away from surface impoundment.   | \$5,000  | 7:26-10.7(f)3    | Feeding hazardous waste into the incinerator during start up and shut down when it is not operating within the conditions of operation in the permit.  | \$10,000 |
| 7:26-10.6(e)5  | Failure to meet requirements for placing ignitable or reactive waste in surface impoundment.  | \$5,000  | 7:26-10.7(f)4i   | Failure of facility owner or operator to keep combustion zone of incinerator totally sealed against fugitive emissions.  | \$3,000  |
| 7:26-10.6(e)6  | Failure to prevent incompatible wastes and/or materials from being placed in same surface impoundment.  | \$5,000  | 7:26-10.7(f)4ii  | Failure of facility owner or operator to maintain combustion zone of incinerator at lower pressure.  | \$3,000  |
| 7:26-10.6(e)8  | Failure of facility owner or operator of surface impoundment to conduct a groundwater decontamination program if groundwater is contaminated.               | \$25,000 | 7:26-10.7(f)4iii | Failure of owner or operator of incinerator to provide approved alternate means of control of fugitive emissions.  | \$3,000  |
| 7:26-10.6(e)9  | Failure to operate surface impoundment in such a way that odors cannot be detected off-site.  | \$2,000  | 7:26-10.7(f)5    | Failure of owner or operator to operate incinerator with automatic feed cut off.   | \$3,000  |
| 7:26-10.6(e)10 | Failure of facility owner or operator to meet requirements before placing acute hazardous waste in surface impoundment.                                     | \$50,000 | 7:26-10.7(f)6    | Failure of facility owner or operator to cease operation of incinerator if change in waste feed or operating conditions exceed permit limits.  | \$5,000  |
| 7:26-10.6(e)11 | Failure of facility owner or operator to comply with each requirement of N.J.A.C. 7:26-10.6(e)11 before placing F020-series waste into surface impoundment. | \$50,000 | 7:26-10.7(f)7i   | Failure of owner or operator of incinerator to fulfill all the conditions of N.J.A.C. 7:27-8 permit.   | \$5,000  |
| 7:26-10.6(f)1  | Failure of facility owner or operator to comply with inspection requirements for surface impoundments prior to and following construction.                  | \$5,000  | 7:26-10.7(f)7ii  | Failure of all components connected or attached to the equipment or control apparatus of the incinerator to be functioning properly or to be used in accordance with N.J.A.C. 7:27-8 permit. | \$5,000  |
| 7:26-10.6(f)2  | Failure of facility owner or operator to comply with inspection requirements during operation and closure of surface impoundments.                          | \$2,000  | 7:26-10.7(h)1    | Failure of owner or operator of incinerator to conduct the following monitoring while incinerating hazardous waste:  |          |
| 7:26-10.6(f)3  | Failure of facility owner or operator of surface impoundment to remedy deterioration or malfunction or condition of permit noncompliance.                   | \$5,000  | 7:26-10.7(h)1i   | Combustion temperature, waste feed rate, auxiliary fuel feed rate, continuously;   | \$2,000  |
| 7:26-10.6(f)4  | Failure of facility owner or operator of surface impoundment to have liners certified by registered professional engineer upon completion of construction.  | \$10,000 | 7:26-10.7(h)1ii  | Carbon monoxide or oxygen, continuously;   | \$2,000  |
| 7:26-10.6(g)1  | Failure of facility owner or operator to remove surface impoundment from service if liquid level suddenly drops or if dike leaks.                           | \$25,000 | 7:26-10.7(h)1iii | Upon request by DEP, sampling or analyses of waste or exhaust emissions.   | \$5,000  |
| 7:26-10.6(g)2  | Failure of facility owner or operator to comply with requirements necessary when surface impoundment is removed from service.                               | \$25,000 | 7:26-10.7(h)1iv  | Upon request by DEP, monitoring on continuous basis of sulfur dioxide, total organics, opacity or other contaminant or parameter specified by the Department.                                | \$5,000  |
| 7:26-10.6(g)3  | Failure of facility owner or operator of surface impoundment to comply with requirements if liquid leaks into leak detection system.                        | \$25,000 | 7:26-10.7(h)2    | Failure of facility owner or operator to completely inspect incinerator or associated equipment at least daily, or to check emergency waste feed cut-off controls or alarm systems daily.    | \$2,000  |
| 7:26-10.6(g)4  | Failure of facility owner or operator to have requirements for surface impoundment in contingency plan.   | \$2,000  | 7:26-10.7(l)1    | Failure of facility owner or operator to remove all hazardous waste and hazardous waste residues from incinerator site.  | \$10,000 |
| 7:26-10.6(g)5  | Failure of facility owner or operator to comply with requirements for placing surface impoundments back into service.                                       | \$25,000 | 7:26-10.7(l)2    | Failure of owner or operator of incinerator to have scrubber water tested and approved by DEP before discharge to POTW or to navigable water.  | \$5,000  |

**ENVIRONMENTAL PROTECTION**

**PROPOSALS**

|                   |   |          |                  |   |          |
|-------------------|---|----------|------------------|---|----------|
| 7:26-10.8(b)      | Failure of hazardous waste landfill to be in compliance with N.J.A.C. 7:14A and applicable provisions of N.J.A.C. 7:26-13.  | \$5,000  | 7:26-10.8(e)13i  | Failure of owner or operator to comply with any conditions contained in DEP authorization.  | \$2,000  |
| 7:26-10.8(d)3     | Failure of owner or operator of hazardous waste landfill to establish gas monitoring system, gas venting program and to notify Department within 30 days of gas detection.                        | \$10,000 | 7:26-10.8(e)14   | Failure of owner or operator of hazardous waste landfill to pump out and properly dispose of leachate collected in secondary system.  | \$10,000 |
| 7:26-10.8(e)1     | Failure of owner or operator of hazardous waste landfill to manage run-on, run-off system after storm.  | \$5,000  | 7:26-10.8(e)15   | Failure of owner or operator of hazardous waste landfill to operate leachate collection system so that leachate depth over primary liner does not exceed one foot.  | \$5,000  |
| 7:26-10.8(e)2     | Failure of owner or operator of hazardous waste landfill to collect run-off.  | \$5,000  | 7:26-10.8(e)17   | Failure of owner or operator of hazardous waste landfill to prevent odors from being detected off-site.   | \$2,000  |
| 7:26-10.8(e)3     | Failure of owner or operator of hazardous waste landfill to remove, treat or dispose of leachate in accordance with N.J.A.C. 7:26 and N.J.A.C. 7:14A.   | \$10,000 | 7:26-10.8(e)18   | Failure of owner or operator of hazardous waste landfill to control insects and rodents.  | \$500    |
| 7:26-10.8(e)4     | Failure of owner or operator of hazardous waste landfill to prevent migration of pollutants into surface waters or groundwater.   | \$10,000 | 7:26-10.8(e)19   | Failure of owner or operator of hazardous waste landfill to control dust.   | \$500    |
| 7:26-10.8(e)6i    | Failure of facility owner or operator to cover hazardous waste landfill.  | \$10,000 | 7:26-10.8(e)21   | Failure of owner or operator of hazardous waste landfill to comply with requirements for F020, F021, F022, F023, F026, and F027 wastes.   | \$10,000 |
| 7:26-10.8(e)6ii   | Failure of owner or operator of hazardous waste landfill to apply daily or intermediate cover to landfill.  | \$5,000  | 7:26-10.8(e)22   | Failure of owner or operator of hazardous waste landfill to use test for determining presence of free liquids before accepting waste.   | \$5,000  |
| 7:26-10.8(e)7     | Operating a hazardous waste landfill within 200 feet of property boundary.  | \$10,000 | 7:26-10.8(g)1i   | Failure of owner or operator of hazardous waste landfill to prevent overpacked drums to be made of material that will react with, or be decomposed or ignited by waste contained from being placed in landfill. | \$5,000  |
| 7:26-10.8(e)8     | Failure of owner or operator of hazardous waste landfill to render ignitable, corrosive or reactive waste to no longer meet definition before placing in hazardous waste landfill.                | \$10,000 | 7:26-10.8(g)1ii  | Failure of owner or operator of hazardous waste landfill to tightly seal overpacked drums before placing in landfill.   | \$2,000  |
| 7:26-10.8(e)9     | Owner or operator of hazardous waste landfill placing incompatible wastes and materials in same landfill cell.  | \$10,000 | 7:26-10.8(g)1iii | Failure of overpacked drums to meet DOT regulations being placed in landfill.   | \$2,000  |
| 7:26-10.8(e)10    | Owner or operator of hazardous waste landfill placing prohibited wastes in hazardous waste landfill:  |          | 7:26-10.8(g)2    | Failure to meet requirements for inside containers of overpacked drums before placing in a hazardous waste landfill.  | \$5,000  |
| 7:26-10.8(e)10i   | Bulk liquids;   | \$10,000 | 7:26-10.8(g)2i   | Failure of metal outer container to be full after packing with inside containers and absorbent material.  | \$5,000  |
| 7:26-10.8(e)10ii  | Non-containerized liquid waste; or  | \$10,000 | 7:26-10.8(g)2ii  | Failure to have absorbent material that is not capable of reacting dangerously with, being decomposed by, or being ignited by the contents inside the containers in accordance with N.J.A.C. 7:26-9.4(e).       | \$5,000  |
| 7:26-10.8(e)10iii | Waste containing free liquid;   | \$10,000 | 7:26-10.8(g)3    | Failure to prevent incompatible wastes from being placed in same outside container.   | \$5,000  |
| 7:26-10.8(e)10iv  | Acute hazardous waste (H) as listed in N.J.A.C. 7:26-8.15(a)5 and toxic waste (T) as listed in N.J.A.C. 7:26-15(a)6.  | \$10,000 | 7:26-10.8(g)4    | Failure to meet requirements for overpacked reactive wastes before placing in hazardous waste landfill.   | \$5,000  |
| 7:26-10.8(e)11    | Failure of owner or operator of hazardous waste landfill to meet criteria before placing containerized waste in landfill.   | \$10,000 | 7:26-10.8(h)2    | Failure to meet inspection requirements for hazardous waste landfill.   | \$2,000  |
| 7:26-10.8(e)12    | Failure of owner or operator of hazardous waste landfill to comply with requirements for containers placed in landfill. Unless they are very small, such as an ampule, containers must be either: |          |                  |   |          |
| 7:26-10.8(e)12i   | At least 90 percent full when placed in landfill; or  | \$2,000  |                  |   |          |
| 7:26-10.8(e)12ii  | Crushed flat, shredded, or similarly reduced in volume to the maximum practical extent before it is buried beneath the surface of landfill.   | \$2,000  |                  |   |          |
| 7:26-10.8(e)13    | Owner or operator of hazardous waste landfill placing hazardous waste in landfill without Department approval if liquid is detected in secondary collection system.                               | \$25,000 |                  |   |          |

11. The violations of N.J.A.C. 7:26-11, Additional Requirements for Hazardous Waste Facilities Operating Under Existing Facility Status, and the civil administrative penalty amounts for each violation, are as set forth in the following table.

**PROPOSALS**

**Interested Persons see Inside Front Cover**

**ENVIRONMENTAL PROTECTION**

| RULE                   | RULE SUMMARY   | BASE PENALTY |                  |  |
|------------------------|--|--------------|------------------|--|
| N.J.A.C. 7:26-11.2(a)2 | Failure of facility owner or operator to prevent hazardous wastes or treatment reagents from being placed in tank if they can cause its inner liner to rupture, leak, corrode, or otherwise fail.                | \$10,000     | 7:26-11.2(f)2    | Failure of owner or operator to prevent the placing of hazardous waste in an unwashed tank which previously held incompatible waste or material, except in compliance with N.J.A.C. 7:26-9.4(e)2.              |
| 7:26-11.2(a)3          | Failure of facility owner or operator to operate uncovered tanks to ensure at least two feet of freeboard, unless tank is equipped with a containment structure, drainage control system or diversion structure. | \$2,000      | 7:26-11.3(a)     | Failure of surface impoundments to have at least two feet of freeboard.  |
| 7:26-11.2(a)4          | Failure of facility owner or operator to provide stop in flow mechanism where hazardous waste is continuously fed into tank.   | \$2,000      | 7:26-11.3(b)     | Failure to provide protective cover for earthen dikes of grass, shale, or rock.  |
| 7:26-11.2(b)1          | Failure of facility owner or operator to provide additional waste analyses or documentation when substantially different waste is stored in tank.  | \$5,000      | 7:26-11.3(c)     | Failure to meet waste analyses and trial test requirements for surface impoundments.   |
| 7:26-11.2(b)1i         | Failure to conduct waste analyses and trial treatment or storage tests; or   | \$5,000      | 7:26-11.3(d)1    | Failure of owner or operator to inspect freeboard level at least once each operating day.  |
| 7:26-11.2(b)1ii        | Failure to obtain written, documented information on similar storage or treatment of similar waste under similar operating conditions to show that all applicable requirements are met.                          | \$5,000      | 7:26-11.3(d)2    | Failure of owner or operator to inspect the surface impoundment, including dikes and vegetation surrounding the dike, at least once a week to detect any leaks, deterioration, or failures in the impoundment. |
| 7:26-11.2(c)1          | Failure of facility owner or operator to inspect tank discharge control equipment at least daily.  | \$1,000      | 7:26-11.3(f)     | Facility owner or operator placing ignitable or hazardous waste in surface impoundment without meeting requirements of N.J.A.C. 7:26-11.3(f).  |
| 7:26-11.2(c)2          | Failure of facility owner or operator to inspect data gathered from tank monitoring equipment at least daily.  | \$1,000      | 7:26-11.3(g)     | Facility owner or operator placing incompatible wastes in same surface impoundment without compliance with N.J.A.C. 7:26-9.4(e)2.  |
| 7:26-11.2(c)3          | Failure of facility owner or operator to inspect level of waste in tank at least daily during operation.   | \$1,000      | 7:26-11.4(a)2    | Failure to conduct collection and handling of run-off as a solid waste.  |
| 7:26-11.2(c)4          | Failure of facility owner or operator to inspect construction materials of the tank for corrosion, leaks, etc. at least weekly.  | \$2,000      | 7:26-11.4(a)3    | Failure to prevent wind dispersion of hazardous waste.   |
| 7:26-11.2(c)5          | Failure of facility owner or operator to inspect construction materials and areas surrounding confinement structures weekly.   | \$1,000      | 7:26-11.4(a)4    | Failure to prohibit disposal or disposal operation within 200 feet of property boundary.   |
| 7:26-11.2(d)           | Failure of facility owner or operator at closure, to remove all hazardous waste and residues from tanks, discharge control equipment, etc;   | \$10,000     | 7:26-11.4(a)5    | Failure of owner or operator of hazardous waste landfill to meet the requirement of daily or intermediate cover in accordance with N.J.A.C. 7:26-2.  |
| 7:26-11.2(e)1          | Failure of facility owner or operator to meet requirements before ignitable or reactive waste is placed in a tank.   | \$5,000      | 7:26-11.4(a)6    | Failure of owner or operator of hazardous waste landfill to treat ignitable or reactive waste before placing in landfill.  |
| 7:26-11.2(e)2          | Failure of facility owner or operator to comply with NFPA requirements for buffer zones for treatment or storage in covered tanks.   | \$5,000      | 7:26-11.4(a)7    | Placing incompatible wastes in same hazardous waste landfill cell.   |
| 7:26-11.2(f)           | Failure of facility owner or operator to comply with requirements for incompatible wastes.   | \$5,000      | 7:26-11.4(a)8    | Placing bulk or non-containerized liquids in landfill without treating liner and liquids and stabilizing liquids.  |
| 7:26-11.2(f)1          | Failure of owner or operator to prevent the placing of incompatible wastes, or wastes and materials, in same tank, except in compliance with N.J.A.C. 7:26-9.4(e)2.  | \$5,000      | 7:26-11.4(a)9    | Placing containerized liquids in hazardous waste landfill.   |
|                        |  |              | 7:26-11.4(a)10i  | Failure to have container, unless very small, such as an ampule, to be either: At least 90 percent full when placed in landfill; or  |
|                        |  |              | 7:26-11.4(a)10ii | Crushed flat, shredded, or similarly reduced in volume to the maximum practical extent before it is buried beneath the surface of landfill.  |
|                        |  |              | 7:26-11.4(a)11   | Failure of owner or operator of hazardous waste landfill to cease disposal if liquid detected in secondary collection system unless authorization from Department for continued disposal has been obtained.    |

**ENVIRONMENTAL PROTECTION**

**PROPOSALS**

|                  |  |          |               |  |          |
|------------------|--|----------|---------------|--|----------|
| 7:26-11.4(b)1    | Failure of facility owner or operator to maintain in operating record details of location and dimensions of each hazardous waste landfill cell.  | \$10,000 | 7:26-11.6(c)  | Failure of facility owner or operator to meet waste analysis requirements for thermal treatment of hazardous waste.  | \$10,000 |
| 7:26-11.4(b)2    | Failure of facility owner or operator to maintain in operating record the contents of each hazardous waste landfill cell and location of each hazardous waste type.  | \$2,000  | 7:26-11.6(d)1 | Failure of facility owner or operator when thermally treating hazardous waste to monitor and inspect instruments relating to temperature and emission control at least every 15 minutes.                   | \$2,000  |
| 7:26-11.4(c)1    | Failure of owner or operator of hazardous waste landfill to place final cover over landfill as required by Department.   | \$50,000 | 7:26-11.6(d)2 | Failure of facility owner or operator when thermally treating hazardous waste to monitor and inspect stack plume, at least hourly.   | \$2,000  |
| 7:26-11.4(c)4i   | Failure of owner or operator of a hazardous waste landfill to maintain the function and integrity of the final cover including making repairs to the cover as necessary to correct the effects of settling, subsidence, erosion or other events. | \$5,000  | 7:26-11.6(d)3 | Failure of facility owner or operator when thermally treating hazardous waste to monitor and inspect process equipment and associated equipment for leaks, spills, etc; at least daily.                    | \$2,000  |
| 7:26-11.4(c)4ii  | Failure of facility owner or operator to maintain and monitor the leachate collection, removal, and treatment system to prevent excess accumulation of leachate in the system.   | \$10,000 | 7:26-11.6(e)  | Failure of facility owner or operator at closure to remove all hazardous waste and residues from thermal treatment process.  | \$10,000 |
| 7:26-11.4(c)4iii | Failure of facility owner or operator to maintain and monitor the gas collection and control system to control the vertical and horizontal escape of gases.  | \$10,000 | 7:26-11.6(f)  | Failure of facility owner or operator to prevent open burning and detonation of waste explosives and highly reactive wastes too close to property line or the open burning of any other hazardous waste.   | \$5,000  |
| 7:26-11.4(c)4iv  | Failure of facility owner or operator to protect and maintain surveyed benchmarks used in complying with N.J.A.C. 7:26-10.4(b)1.   | \$5,000  | 7:26-11.7(a)2 | Failure of facility owner or operator to prevent placing of hazardous wastes in treatment process if they could cause process to leak, corrode or fail.  | \$5,000  |
| 7:26-11.4(c)4v   | Failure of facility owner or operator to restrict access to the hazardous waste landfill as appropriate for its post-closure use.  | \$10,000 | 7:26-11.7(a)3 | Failure of facility owner or operator to provide continuously fed treatment process with a mechanism to stop inflow.   | \$3,000  |
| 7:26-11.4(c)4vi  | Failure of facility owner or operator to maintain and monitor groundwater monitoring system as per N.J.A.C. 7:26-9.5 or N.J.A.C. 7:14A-6.  | \$25,000 | 7:26-11.7(b)  | Failure of facility owner or operator to provide additions to waste analysis required by N.J.A.C. 7:26-9.4(b) for substantially different waste.   | \$5,000  |
| 7:26-11.4(c)4vii | Failure of facility owner or operator to prevent run-on and run-off from eroding or otherwise damaging the final cover.  | \$3,000  | 7:26-11.7(c)1 | Failure of facility owner or operator to monitor and inspect discharge control and safety equipment at least once each operating day.  | \$2,000  |
| 7:26-11.5(b)1    | Failure of facility owner or operator, before adding hazardous waste, to bring incinerator to normal operating conditions.   | \$10,000 | 7:26-11.7(c)2 | Failure of facility owner or operator to gather data from monitoring equipment at least once each operating day.   | \$2,000  |
| 7:26-11.5(c)1    | Failure of facility owner or operator to meet waste analysis requirements for hazardous waste incinerators.  | \$10,000 | 7:26-11.7(c)3 | Failure of facility owner or operator to inspect construction materials at least weekly.   | \$2,000  |
| 7:26-11.5(d)1    | Failure of facility owner or operator when incinerating hazardous waste to monitor instruments relating to combustion and emission control at least every 15 minutes.  | \$2,000  | 7:26-11.7(c)4 | Failure of facility owner or operator to monitor and inspect discharge confinement structures for erosion, leakage, etc. at least weekly.  | \$1,000  |
| 7:26-11.5(d)2    | Failure of facility owner or operator when incinerating hazardous waste to observe stack plume at least hourly.  | \$2,000  | 7:26-11.7(d)  | Failure of facility owner or operator to remove all hazardous waste and residues at closure.   | \$10,000 |
| 7:26-11.5(d)3    | Failure of facility owner or operator to inspect complete incinerator and associated equipment for leaks, spills, etc. at least daily.   | \$2,000  | 7:26-11.7(e)  | Failure of facility owner or operator to prevent placing ignitable or reactive waste in treatment process unless it is treated according to 7:26-11.7(e).  | \$10,000 |
| 7:26-11.5(e)     | Failure of facility owner or operator to remove all hazardous wastes and residues from the incinerator at closure.   | \$10,000 | 7:26-11.7(f)1 | Failure of facility owner or operator to prevent the placing of incompatible wastes, which are not in compliance with N.J.A.C. 7:26-9.4(e), in the treatment process.                                      | \$5,000  |
| 7:26-11.6(b)     | Failure of facility owner or operator to bring thermal treatment process to normal operating conditions before adding hazardous waste.   | \$10,000 | 7:26-11.7(f)2 | Failure of facility owner or operator to prevent the placing of hazardous waste in an unwashed tank which previously held incompatible waste or material, except in compliance with N.J.A.C. 7:26-9.4(e)2. | \$5,000  |

**PROPOSALS**

**Interested Persons see Inside Front Cover**

**ENVIRONMENTAL PROTECTION**

12. The violations of N.J.A.C. 7:26-12, Hazardous Waste Facility Permit Requirements, and the civil administrative penalty amounts or each violation, are as set forth in the following table.

| RULE             | RULE SUMMARY   | BASE PENALTY |
|------------------|--|--------------|
| N.J.A.C.         |  |              |
| 7:26-12.1(a)     | Construction, installation, modification or operation of hazardous waste facility, without submitting Part A or Part B of permit application.  | \$50,000     |
| 7:26-12.3(b)1    | Treating, storing or disposing of hazardous waste types not specified in Part A.   | \$25,000     |
| 7:26-12.3(b)2    | Employing processes not specified in Part A application.   | \$50,000     |
| 7:26-12.3(b)3    | Exceeding design capacities or operational limits specified in Part A of the permit application.   | \$50,000     |
| 7:26-12.3(c)4    | Change in ownership or operational control without receiving approval by Department.   | \$50,000     |
| 7:26-12.3(c)5    | Facility owner or operator making changes to existing facility, prior to final disposition of permit application, which amount to reconstruction of facility.                        | \$50,000     |
| 7:26-12.3(g)     | Failure of facility owner or operator, no longer eligible to continue operation prior to final disposition of permit application, to commence closure immediately.                   | \$10,000     |
| 7:26-12.4(a)4    | Failure of permittee to take all reasonable steps to minimize or correct any adverse impact on the environment resulting from noncompliance with permit.                             | \$10,000     |
| 7:26-12.4(a)8    | Failure of permittee to furnish to the Department within a reasonable time, any information which the Department may request and copies of records required to be kept.              | \$10,000     |
| 7:26-12.4(a)9ii  | Failure of permittee to allow an authorized representative of the Department to enter and have access to and copy any records that shall be kept under the conditions of the permit. | \$5,000      |
| 7:26-12.4(a)9iv  | Failure of permittee to allow authorized representative of the Department to enter and to sample or monitor any substances or parameters at any location.                            | \$25,000     |
| 7:26-12.4(a)10i  | Failure to retain records with each piece of required information regarding monitoring sampling and measurements.  | \$5,000      |
| 7:26-12.4(a)11   | Failure to sign and certify all applications, reports or information submitted to DEP.   | \$2,000      |
| 7:26-12.4(a)12i  | Failure of permittee to give notice to DEP as soon as possible of any planned physical alterations or additions to permitted facility.   | \$5,000      |
| 7:26-12.4(a)12ii | Failure to give advance notice to the Department of any planned changes in the permitted facility or activity which may result in noncompliance with permit requirements.            | \$5,000      |
| 7:26-12.4(a)12iv | Failure to report monitoring results at intervals specified in permit.   | \$5,000      |

|                    |   |          |
|--------------------|---|----------|
| 7:26-12.4(a)12v    | Failure to submit compliance reports on interim or final requirements in any compliance schedule within 14 days after schedule date.  | \$1,000  |
| 7:26-12.4(a)12vi   | Failure to report any noncompliance which may endanger health or environment, orally within 24 hours or in writing within five days.  | \$10,000 |
| 7:26-12.4(a)12vii  | Failure to report all instances of non-compliance not reported under N.J.A.C. 7:26-12.4(a)12iv, v or vi, at time monitoring reports submitted.  | \$2,000  |
| 7:26-12.4(a)12viii | Failure of permittee who becomes aware that it failed to submit any relevant facts in a permit application, or submitted incorrect information in a permit application or report to the Department, to promptly submit such facts or information.   | \$2,000  |
| 7:26-12.4(a)14     | Failure of permittee to maintain records from each required monitoring well, and for disposal facilities for post closure care period.  | \$5,000  |
| 7:26-12.4(a)15     | Permittee commencing treatment, storage, or disposal of hazardous waste at new or modified portion of facility, without certifying that facility has been constructed or modified in accordance with permit, or without Department inspection.  | \$50,000 |
| 7:26-12.4(a)16i    | Failure to report, orally within 24 hours, information concerning release of any hazardous waste that may cause an endangerment to public drinking water supplies.  | \$25,000 |
| 7:26-12.4(a)16ii   | Failure to report, orally within 24 hours, information concerning a release or discharge of hazardous waste, or of a fire or explosion from a hazardous waste facility which could threaten the environment or human health outside the facility.   | \$10,000 |
| 7:26-12.5(b)       | Failure of permittee to give Department required notification in advance of any proposed change of ownership or operational control.  | \$50,000 |
| 7:26-5.5           | Civil administrative penalty determination—discretionary  |          |
|                    | (a) Notwithstanding N.J.A.C. 7:26-5.4, the Department may, in its discretion, assess a civil administrative penalty pursuant to this section of not more than \$50,000 for each violation of the Act, or any rule promulgated, any administrative order, permit, license or other operating authority issued, any district solid waste management plan approved, or any Part A permit application filed, pursuant to the Act. |          |
|                    | (b) Each violation of the Act, or any rule promulgated, any administrative order, permit, license or other operating authority issued, any district solid waste management plan approved, or any Part A permit application filed, and any parameter contained therein, pursuant to the Act, shall constitute an additional, separate and distinct violation.  |          |
|                    | (c) Each day during which a violation continues shall constitute an additional, separate and distinct violation.  |          |
|                    | (d) For each parameter that is required to be monitored, sampled or reported, the failure to so monitor, sample or report shall constitute an additional, separate and distinct violation.  |          |
|                    | (e) Where any requirement of the Act, or any rule promulgated, any administrative order, permit, license or other operating authority issued, any district solid waste management plan approved, or any Part A permit application filed, pursuant to the Act, may pertain   |          |

to more than one act, condition, occurrence, item, unit, waste or parameter, the failure to comply with such requirement as it pertains to each such act, condition, occurrence, item, unit, waste or parameter shall constitute an additional, separate and distinct violation.

(f) Notwithstanding N.J.A.C. 7:26-5.4, and unless the Department assesses a civil administrative penalty pursuant to N.J.A.C. 7:26-5.6 through N.J.A.C. 7:26-5.8, the Department shall assess a civil administrative penalty for violations described in this section on the basis of the seriousness of the violation and the conduct of the violator at the mid-point of the following ranges, unless adjusted pursuant to (i) below.

|         |          | SERIOUSNESS |           |           |
|---------|----------|-------------|-----------|-----------|
|         |          | Major       | Moderate  | Minor     |
| CONDUCT | Major    | \$40,000-   | \$30,000- | \$15,000- |
|         |          | \$50,000    | \$40,000  | \$25,000  |
|         | Moderate | \$30,000-   | \$10,000- | \$3,000-  |
|         |          | \$40,000    | \$20,000  | \$6,000   |
|         | Minor    | \$15,000-   | \$3,000-  | \$1,000-  |
|         |          | \$25,000    | \$6,000   | \$2,500   |

(g) The seriousness of the violation shall be determined as major, moderate or minor as follows:

1. Major seriousness shall apply to any violation which:
  - i. Has caused or has the potential to cause serious harm to human health or the environment; or
  - ii. Seriously deviates from the requirements of the Act, or any rule promulgated, any administrative order, permit, license or other operating authority issued, any district solid waste management plan approved, or any Part A permit application filed, pursuant to the Act; serious deviation shall include, but not be limited to, those violations which are in complete contravention of the requirement, or if some of the requirement is met, which severely impair or undermine the operation or intent of the requirement;
2. Moderate seriousness shall apply to any violation which:
  - i. Has caused or has the potential to cause substantial harm to human health or the environment; or
  - ii. Substantially deviates from the requirements of the Act, or any rule promulgated, any administrative order, permit, license or other operating authority issued, any district solid waste management plan approved, or any Part A permit application filed, pursuant to the Act; substantial deviation shall include, but not be limited to, violations which are in substantial contravention of the requirements or which substantially impair or undermine the operation or intent of the requirement; and
3. Minor seriousness shall apply to any violation not included in (g)1 or 2 above.

(h) The conduct of the violator shall be determined as major, moderate or minor as follows:

1. Major conduct shall include any intentional, deliberate, purposeful, knowing or willful act or omission by the violator;
  2. Moderate conduct shall include any unintentional but foreseeable act or omission by the violator; and
  3. Minor conduct shall include any other conduct not included in (h)1 or 2 above.
- (i) The Department may, in its discretion, adjust the amount determined pursuant to (f), (g) and (h) above to assess a civil administrative penalty in an amount no greater than the maximum amount nor less than the minimum amount in the range described in (f) above, on the basis of the following factors:

1. The compliance history of the violator;
2. The number, frequency and/or severity of violation(s) by the violator;
3. The measures taken by the violator to mitigate the effects of the current violation or prevent future violations;
4. The deterrent effect of the penalty; and/or
5. Other specific circumstances of the violator or the violation.

**7:26-5.6 Civil administrative penalty for submitting inaccurate or false information**

(a) The Department may assess a civil administrative penalty pursuant to this section against each violator who submits inaccurate

information or who makes a false statement, representation or certification in any application, record or other document required to be submitted or maintained pursuant to the Act, or any rule promulgated, any administrative order, permit, license or other operating authority issued, any district solid waste management plan approved, or any Part A permit application filed, pursuant to the Act.

(b) Each day, from the day that the violator knew or had reason to know that it submitted inaccurate or false information to the Department until the day of receipt by the Department of a written correction by the violator, shall be an additional, separate and distinct violation.

(c) The Department shall assess a civil administrative penalty for violations described in this section based on the conduct of the violator at the mid-point of the following ranges except as adjusted pursuant to (d) below:

1. For each intentional, deliberate, purposeful, knowing or willful act or omission by the violator, the civil administrative penalty per act or omission shall be in an amount of not more than \$50,000 nor less than \$40,000 per act or omission; and

2. For all other conduct, the civil administrative penalty, per act or omission, shall be in the amount of \$1,000 per violation.

(d) The Department may, in its discretion, adjust the amount determined pursuant to (c) above to assess a civil administrative penalty in an amount no greater than the maximum amount nor less than the minimum amount in the range described in (c) above, or the basis of the following factors:

1. The compliance history of the violator;
2. The number, frequency and/or severity of violation(s) by the violator;
3. The measures taken by the violator to mitigate the effects of the current violation or prevent future violations;
4. The deterrent effect of the penalty; and/or
5. Other specific circumstances of the violator or the violation.

**7:26-5.7 Civil administrative penalty for failure to allow lawful entry and inspection**

(a) The Department may assess a civil administrative penalty pursuant to this section against any violator who refuses, inhibits or prohibits immediate lawful entry and inspection by any authorized Department representative of any premises, building or facility which the Department may enter and inspect pursuant to the provisions of the Act.

(b) Each day that a violator refuses, inhibits or prohibits immediate lawful entry and inspection by an authorized Department representative of any premises, building or facility which the Department may enter and inspect pursuant to the provisions of the Act, shall be an additional, separate and distinct violation.

(c) The Department shall assess a civil administrative penalty for violations described in this section at the mid-point of the following ranges except as adjusted pursuant to (d) below as follows:

1. For refusing, inhibiting or prohibiting immediate lawful entry and inspection of any premises, building or facility for which an administrative order, permit, license or other operating authority requirement exists under the Act, the civil administrative penalty shall be in an amount of not more than \$30,000 nor less than \$20,000 per violation; and

2. For any other refusal, inhibition, or prohibition of immediate lawful entry and inspection the civil administrative penalty shall be in an amount of not more than \$5,000 nor less than \$3,000 per violation.

(d) The Department may, in its discretion, adjust the amount determined pursuant to (c) above to assess a civil administrative penalty in an amount no greater than the maximum amount nor less than the minimum amount in the range described in (c) above, on the basis of the following factors:

1. The compliance history of the violator;
2. The number, frequency and/or severity of violation(s) by the violator;
3. The measures taken by the violator to mitigate the effects of the current violation or prevent future violations;
4. The deterrent effect of the penalty; and/or

5. Other specific circumstances of the violator or the violation.

7:26-5.8 Civil administrative penalty for failure to pay a fee

(a) The Department may assess a civil administrative penalty pursuant to this section against each violator who fails to pay a fee when due pursuant to the Act, or any rule promulgated, any administrative order, permit, license or other operating authority issued, any district solid waste management plan approved, or any Part A permit application filed, pursuant to the Act.

(b) Each day a fee is not paid after it is due shall constitute an additional, separate and distinct violation.

(c) For violations described in this section, the amount of the civil administrative penalty shall be equal to the unpaid fee, up to a maximum of \$50,000 per violation.

7:26-5.9 Civil administrative penalty for economic benefit

The Department may, in addition to any other civil administrative penalty assessed pursuant to this subchapter, in its discretion include as a civil administrative penalty the economic benefit (in dollars) which the violator has realized as a result of not complying with, or by delaying compliance with, the requirements of the Act, or any rule promulgated, any administrative order, permit, license or other operating authority issued, any district solid waste management plan approved, or any Part A permit application filed, pursuant to the Act. If the total economic benefit was derived from more than one violation, the total economic benefit may be apportioned among the violations from which it was derived so as to increase each civil administrative penalty assessment to an amount no greater than \$50,000 per violation.

7:26-5.10 Severability

If any provision of this subchapter or the application thereof to any person or circumstances is held invalid, such invalidity shall not affect other provisions or applications, and to this end, the provisions of this subchapter are declared to be severable.

## HUMAN SERVICES

### (a)

#### DIVISION OF MENTAL HEALTH AND HOSPITALS

#### Transfers of Involuntarily Committed Patients Between State Psychiatric Facilities

#### Proposed New Rules: N.J.A.C. 10:36-3

Authorized By: Drew Altman, Commissioner, Department of Human Services.

Authority: N.J.S.A. 30:4-27.21a.

Proposal Number: PRN 1989-454.

Submit comments by October 5, 1989 to:

Alan G. Kaufman, Director  
Division of Mental Health and Hospitals  
CN 700  
Trenton, NJ 08625

The agency proposal follows:

#### Summary

N.J.S.A. 30:4-27.21a requires that: "A person involuntarily committed to a State psychiatric facility listed in R.S.30:1-7 may be transferred to another State psychiatric facility in accordance with rules adopted by the Commissioner that specify the clinical and programmatic factors and the procedures related to transfer." The rules herein proposed specify those factors and procedures.

The Commissioner of the Department of Human Services is authorized to make the most appropriate placement possible for civilly committed individuals. The Commissioner generally provides that the appropriate mental health facility for involuntarily committed patients should be determined by catchment area based on the patient's residence. Since all regional State psychiatric facilities offer minimally the same clinical modalities, each patient shall, unless there is good reason to do otherwise, be placed in the regional State psychiatric facility serving his or her catchment area.

When it becomes necessary to transfer an involuntary patient from one State psychiatric facility to another, that transfer shall be justified by reference to one or more of the clinical, programmatic, and administrative factors identified in these rules.

#### Social Impact

The proposed new rules will have a positive social impact for patients and their relatives by defining the process for carrying out inter-hospital transfers and by clarifying the clinical, social, and administrative factors for initiating those transfers. In this way, the rules will help to ensure that the patient receives appropriate treatment in an appropriate program consistent with all applicable law. By assisting in the designation of appropriate placements in the hospitals, the rules also foster clinical environments that are as therapeutic as possible for patients in all the State's facilities.

#### Economic Impact

By creating a systematic approach to inter-hospital transfers, the rules should foster cost-effective programming in some instances by placing patients within more reasonable commuting distances of relatives and locally-assigned community liaisons.

#### Regulatory Flexibility Statement

The proposed rules would not affect small businesses as defined in the Regulatory Flexibility Act, N.J.S.A. 52:14B-16 et seq. The State psychiatric hospitals in New Jersey all employ more than 100 persons.

Full text of the proposal follows:

### SUBCHAPTER 3. TRANSFERS OF INVOLUNTARILY COMMITTED PATIENTS BETWEEN STATE PSYCHIATRIC FACILITIES

#### 10:36-3.1 Purpose

The purpose of this subchapter is to define the factors to be used by State psychiatric facility staff in evaluating the need for inter-hospital transfers among the facilities cited in N.J.A.C. 10:36-3.2. The subchapter also delineates the procedures related to such transfers.

#### 10:36-3.2 Scope

(a) The rules of this subchapter apply in all instances to involuntarily committed patients who are residing at and being considered for transfer to any of the following facilities specified in N.J.S.A. 30:4-160:

1. Greystone Park Psychiatric Hospital;
2. Trenton Psychiatric Hospital;
3. Marlboro Psychiatric Hospital;
4. Ancora Psychiatric Hospital; and
5. The Forensic Psychiatric Hospital.

#### 10:36-3.3 Factors

(a) Any of the factors described below may serve as a basis for the transfer of a patient from and to any facility cited in N.J.A.C. 10:36-3.2:

1. To place him or her in closer proximity to family members;
2. To place the patient in the appropriate hospital according to the patient's residence (catchment area);
3. To provide a new clinical and personal relationship when a treatment impasse has developed over a sustained period of time;
4. To provide greater or lesser clinical structure or security;
5. To participate in a specialized psychiatric service that is offered at another hospital or in the community that is more accessible from the receiving hospital;
6. As a result of a change in legal status;
7. To spare patients the consequences of overcrowding at a specific mental health facility;
8. In response to natural catastrophes, fires, or other life-safety concerns which necessitate transfer; and
9. As a consequence of inter-regional consolidation of services.

#### 10:36-3.4 Procedures

(a) A written request for transfer, supported by a statement of the factors justifying the request, shall be forwarded from the chief executive officer (CEO) or designee of the sending institution to the chief executive officer or designee of the receiving institution. Transfers shall be subject to clinical review. A copy of that request is to be sent to the Assistant Director, Office of Quality Assurance.

(b) Transfers occurring as a result of overcrowding, life-safety concerns, natural catastrophes, or consolidation of services shall require the approval of the Director, Division of Mental Health and Hospitals.

(c) The following procedures shall be followed in cases of non-emergent transfers:

1. The designee of the sending institution must consult with the designee of the receiving institution. If they agree to the transfer, they will arrange for a specific date and time for the transfer to occur.

2. It is the responsibility of the institution initiating the transaction to make arrangements for transfers, including arrangements for transporting the patient from one facility to the other.

3. If the designees do not agree on the transfer, the matter shall be referred to the CEO's of the respective institution for resolution.

4. If the chief executive officers do not agree, the case is to be referred for resolution to the appropriate regional Assistant Directors, Division of Mental Health and Hospitals, who may, in making their decision, request clinical and technical input from central office staff. Resolution, in instances of continuing disagreement, rests with the Division Director or the Director's designee.

5. All transfer requests are to be handled in a timely manner.

(d) The following procedures shall be followed in cases of emergency transfers:

1. Emergency transfers are those that must be resolved after hours or on weekends or have clinical or administrative urgency.

2. The designee or, when unavailable, the administratively responsible person of the sending institution must contact directly his or her counterpart at the receiving institution and transmit verbally the factors supporting the transfer, as well as the reasons for the emergent nature of the transfer. This information must be submitted, in writing, to the receiving institution by close of the first regular business day after the transfer.

3. For the purpose of this section, "clinical urgency" means that the patient being proposed for transfer is considered by his or her clinicians as imminently dangerous to self or others or an imminent security risk if not immediately transferred. That finding is also to have been endorsed by the chief executive officer or designee on call.

4. If, after transfer, the CEO of the receiving institution objects to an emergency transfer, he or she may review the case with the CEO of the sending institution. If agreement cannot be reached, it is referred to the Assistant Director of the receiving region.

5. That Assistant Director shall consult with his or her counterpart from the sending region to resolve the issue.

6. If agreement cannot be reached by the Assistant Directors, the issue shall be referred for resolution to the Director or the Director's designee.

## (a)

### DIVISION OF MEDICAL ASSISTANCE AND HEALTH SERVICES

#### Long Term Care Services Manual

#### Proposed Readoption: N.J.A.C. 10:63

Authorized By: Drew Altman, Commissioner, Department of Human Services.

Authority: N.J.S.A. 30:4D-6a(4)(a), b(14), 7, 7a, b, and c; 30:4D-12.

Proposal Number: PRN 1989-447.

Submit comments by October 5, 1989 to:

Henry W. Hardy, Esq.  
Administrative Practice Officer  
Division of Medical Assistance  
and Health Services  
CN-712  
Trenton, NJ 08625

The agency proposal follows:

#### Summary

Pursuant to Executive Order No. 66(1978) the Long Term Care Services Manual (N.J.A.C. 10:63) expires on November 29, 1989. The Division of Medical Assistance and Health Services has reviewed these rules and determined them to be necessary, reasonable, adequate, efficient, understandable, and responsive to the purpose for which they were originally promulgated. The re-adoption of all three subchapters is necessary because they describe the general provisions relating to patient care and services, billing procedures, and the CARE (Cost Accounting and Rate Evaluation System) Guidelines.

The term long term care facility (LTCF) includes both a skilled nursing facility (SNF) and an intermediate care facility (ICF).

Subchapter 1, entitled General Provisions, describes the required services that must be provided by an LTCF; additional Medicaid services, such as laboratory and X-ray services, vision care services, dental services, etc., which must be arranged for by an LTCF; recordkeeping requirements; utilization control; pharmaceutical services; the authorization process; and audit procedures. In addition, there is a section that describes the patient's rights in an LTCF (N.J.A.C. 10:63-1.9), and another section that sets forth the requirements for the use of the patient's income for personal needs allowance (PNA) in an LTCF (N.J.A.C. 10:63-1.19).

Subchapter 2 describes the billing procedures. The Division is in the process of developing rules which describe recent modifications to the billing procedures LTCFs are required to follow.

Subchapter 3 describes the CARE Guidelines which are the methodology used to establish prospective per diem rates. LTCFs are reimbursed on a per diem basis for the Medicaid patients in their facility.

The rules have been amended since the previous re-adoption. Time frames for certification, recertification, and plan of care were modified to reflect requirements contained in Federal legislation. Certification and recertification is the process whereby a physician attests to a patient's need for a specific type or level of care. Certification and recertification must be completed within the prescribed time frames. A written plan of care for each patient must be completed within the prescribed time frames (R.1985, d.703, effective January 21, 1986). The rules were also amended to clarify issues relating to the patient's personal needs allowance (PNA). The rule clarified those expenses that were included as part of the LTCF's per diem rate, and would not be paid out of the patient's PNA funds, as opposed to those items which were not normally part of the LTCF's costs and would have to be purchased by the patient. The rule also explained the requirements that an LTCF had to follow if they assumed fiduciary responsibility for a patient's PNA funds. In addition, the rule described the procedures to be followed when a patient dies or is transferred from the facility (R.1988, d.556, effective December 5, 1988).

The CARE Guidelines were amended to make provision for reimbursement of governmental LTCFs under the governmental peer grouping system (R.1987, d.6, effective January 5, 1987).

#### Social Impact

The rules impact on those Medicaid patients who require minimal or substantial assistance with personal care needs on a daily basis, and who reside in an LTCF. There are approximately 26,000 Medicaid patients in LTCFs. The rules need to be continued so that these patients can continue to receive these services.

The rules impact on LTCFs, who are required to provide services within the prescribed time frames, submit billings timely and accurately, and prepare cost reports correctly.

#### Economic Impact

The Division of Medical Assistance and Health Services expenditure for long term care in State Fiscal Year 1989 is approximately \$575,000,000 (Federal-State share combined).

The rules that are proposed for re-adoption include a portion of the CARE (Cost Accounting and Rate Evaluation) Guidelines which describe the methodology to be used to establish prospective per diem rates for the providing of routine patient care to patients under the New Jersey Title XIX (Medicaid) Program (see N.J.A.C. 10:63-3). LTCFs are required to complete and submit cost reports based on these guidelines. Penalties are imposed for failure to submit cost reports timely (reference is made to N.J.A.C. 10:63-3.1). These guidelines are used to establish per diem rates which are the basis of Medicaid reimbursement. All rates established pursuant to these guidelines will be subject to on-site audit verification of costs and statistics reported by LTCFs. There is no change in the CARE Guidelines associated with this re-adoption.

Medicaid patients are required to contribute towards the cost of their care from their available income.

This chapter should be continued to insure Federal matching funds for his service.

#### Regulatory Flexibility Analysis

The rules apply equally to all LTCFs, whether or not they would be considered small businesses under the terms of the New Jersey Administrative Procedure Act. The type of professional services that are needed to comply with the rules include, but are not limited to, physicians, nurses, and social service staff. In addition, an LTCF may engage the services of other health professionals when the patient's condition requires treatment not provided directly by the LTCF.

As a condition of participation in the New Jersey Medicaid Program, LTCFs are required to maintain medical, nursing, social, and patient activity records to comply with Federal and State law and regulations. LTCFs are also required to maintain records relating to patient income, including patient personal needs allowance accounts. The records relating to patient care and patient income are necessary for the health, safety and general welfare of the patients in LTCFs.

LTCFs are required to maintain billing records and to submit monthly transactions via the appropriate form to the Division. One purpose of the monthly billing is to add and delete Medicaid patients to insure accurate reimbursement. LTCFs are also provided with a computer generated transaction listing the payment and any error messages. LTCFs are required to verify the accuracy of the payment and to take necessary action to resolve the error messages so that processing can be resumed. LTCFs are also required to submit monthly an MCNH-30 (certification statement) wherein the LTCF administrator is required to certify, as a minimum, the lowest semi-private room rate, and that the LTCF complies with Federal and State law and regulations.

The costs for providing patient care are included in the LTCF's cost report, which must be submitted annually and is the basis for establishing the LTCF's reimbursement.

This proposed readoption does not change the existing requirements of N.J.A.C. 10:63. There are no additional reporting, recordkeeping or other compliance requirements associated with this readoption. There are no capital costs associated with the readoption.

The Division does not believe a differentiation in requirements based on business size is required because the existing requirements are necessary for the public health, safety, and general welfare of the Medicaid patients in LTCFs. In addition, Medicaid providers are required by law to maintain sufficient records to fully document the name of the recipient to whom the service was rendered, the date of the service, nature and extent of the service, etc., and to present sufficient documentation in order to be reimbursed for the services they render. (N.J.S.A. 30:4D-12).

Full text of the proposed readoption may be found at N.J.A.C. 10:63.

### (a)

#### COMMISSION FOR THE BLIND AND VISUALLY IMPAIRED

#### Organization and General Policy Provisions of the Commission for the Blind and Visually Impaired

#### Proposed New Rules: N.J.A.C. 10:91

#### Proposed Repeal: N.J.A.C. 10:95

Authorized By: Drew Altman, Commissioner, Department of Human Services.

Authority: N.J.S.A. 30:1-12; 52:14B-3(1) et seq.

Proposal Number: PRN 1989-450.

Submit comments by October 5, 1989 to:

Michael E. Cassels, Administrative Practice Officer  
Commission for the Blind and Visually Impaired  
1100 Raymond Boulevard  
Newark, NJ 07102

The agency proposal follows:

#### Summary

The New Jersey Administrative Code at N.J.A.C. 10:95 sets forth the rules describing the organization of the Commission for the Blind and Visually Impaired, hereinafter referred to as the Commission. The Com-

mission was designated by N.J.S.A. 30:6-1 to provide "all means which it deems feasible for ameliorating the condition of the blind and visually impaired within the State."

Pursuant to Executive Order No. 66(1978), N.J.A.C. 10:95 expired August 23, 1989. The Commission has reviewed the rules set out in N.J.A.C. 10:95 and has decided to propose a repeal of N.J.A.C. 10:95 and to propose new rules concerning the operations and procedures of the Commission to follow more closely the language and intent of Federal law and regulation and State law governing the services rendered by the Commission. The proposed repeal is being made at N.J.A.C. 10:95-1.1, Composition and functions of the Commission, and at N.J.A.C. 10:95-1.2, Responsibilities and goals. Additionally, the new rules at N.J.A.C. 10:91 are being proposed because of current efforts of the Commission to convert appropriate policy material now contained in the Commission's operations manuals, and identified as rules, into proper rule form (see *Metromedia, Inc. v. Director, Division of Taxation*, 97 N.J. 313 (1984)).

The proposed new rules will more clearly inform the public of the procedures, standards, and responsibilities of the Commission and the client's rights and responsibilities with reference to these rules.

An overview of the Commission's four client service programs is found at N.J.A.C. 10:91-1.3, Education services, N.J.A.C. 10:91-1.4, Allied independent living services, N.J.A.C. 10:91-1.5, Allied prevention services, and N.J.A.C. 10:91-1.6, Vocational rehabilitation services. This overview gives a brief description of these service programs, that will be developed further in additional chapters, currently being written, which will detail the specific rules applicable to these programs. Therefore, the new rules at N.J.A.C. 10:91 contain references to the rules currently being written and are identified for future reference as N.J.A.C. 10:92, Education Services, N.J.A.C. 10:93, Allied Independent Living Services, N.J.A.C. 10:94, Allied Prevention Services, and N.J.A.C. 10:95, Vocational Rehabilitation Services. With respect to N.J.A.C. 10:91-1.4 and 1.5, it should be noted that the Commission's allied services program is broken down into two discrete areas, independent living and prevention, because of the different service objectives involved with each program.

A summary of the proposed new rules follows:

Proposed N.J.A.C. 10:91-1 describes the organizational structure of the Commission and briefly details the purpose and scope of its four client service programs, as well as the authority which empowers it to carry out these services and to maintain a record of all known blind individuals within the State. The proposed subchapter discusses the functions of the Commission's consumer advisory boards, its internal client advocate, the issue of legal guardianship of a client, and a section on definition of terms peculiar to the Commission.

Proposed N.J.A.C. 10:91-2 reflects the statutory standards set out at N.J.S.A. 30:6-1 et seq. and describes the eligibility standards used by the Commission to determine if an individual qualifies for its services and the need for accurate eye information which is the basis for its eligibility determinations. Residency requirements are also discussed.

Proposed N.J.A.C. 10:91-3 details the standards used by the Commission to determine a client's responsibility to pay for certain services, as well as their making use of any similar benefits which are considered "first dollar resource" to be used before the expenditure of Commission funds. This subchapter also discusses those services available to clients at no cost to them. Based on the limits of its annual legislative appropriation and the need for the Commission to fulfill its statutory mandate to ameliorate the condition of the blind and visually impaired, defray the costs of board, tuition and other training related expenses (N.J.S.A. 30:6-1; 30:6-11), the Commission requires that clients who can afford it participate in the costs of services rendered by the Commission. The Commission thus uses a set of guidelines that reflect a consistent application of financial income and asset standards based on Federal poverty guidelines (42 U.S.C. 9902(2)).

Proposed N.J.A.C. 10:91-4 outlines the Commission services available to all New Jersey residents, such as screening programs, as well as the services available to applicants and to eligible clients. The Commission's client assistance fund, which provides loans or grants to eligible clients for certain financial emergencies, is also discussed.

Proposed N.J.A.C. 10:91-5 describes procedures to be followed from the time an individual is referred to the Commission as a potential applicant for services through to closure of the client's case from services.

This subchapter discusses assignment of primary and ancillary caseworkers who are responsible for developing the various service plans with clients. These service plans are described and detail the services a client is to receive in order to meet his or her rehabilitation goals. The purchase of services in behalf of clients is discussed, as well as the function

of the Commission's program development and contract unit in meeting the service needs of clients through the services of provider agencies. The subchapter reviews client confidentiality with reference to the release of information and access to client records. The subchapter also deals with the time limitation standards used by the Commission in an effort to ensure prompt delivery of services. Additionally, this subchapter reviews the issues of communicable diseases, the reporting of abuse of the elderly and children, as well as the handling of incidents involving clients.

Proposed N.J.A.C. 10:91-6 deals with the clients' ability to avail themselves of the means to address any concerns they may have about the timeliness and adequacy of the services they are receiving or should be receiving. The subchapter discusses the informal and formal means a client has to resolve issues affecting them.

Proposed N.J.A.C. 10:91-7 sets forth the Commission's liability with regard to payment for medical services to be provided or being provided to clients. The basis for determining fees payable, as well as information on the actual fees allowed for services, is also proposed.

#### Social Impact

The proposed repeal and new rules will benefit the blind and visually impaired by providing them with timely notice of services available through the Commission. The proposed repeal and new rules will further benefit these individuals by setting forth the application procedures for services and the criteria and standards used by the Commission in determining eligibility for services, client rights and responsibilities and, where applicable, client responsibility in participating in paying for the cost of services. Additionally, the proposed new rules will benefit the blind and visually impaired by setting forth the standards for protecting their rights and the procedures for appealing any Commission action or inaction.

The proposed repeal and new rules will benefit the Commission in that the procedures and standards used for the provision of services will be clearly identified in rules.

#### Economic Impact

There is no economic impact associated with the proposed new rules as these rules merely reflect procedures, standards and services which provide rehabilitation benefits for clients of the Commission that were already available under the Federal law and State law, rules and policies. Specifically, the financial survey form and the financial participation worksheet are instruments used by the Commission to determine when a client may be able to participate in payment for services. The instruments themselves are designed to minimize any burden on clients. Of 10,225 clients served in Fiscal Year 1988, approximately 100 were required to contribute to the cost of services.

With regard to the fee schedule set forth at proposed N.J.A.C. 10:91-7.1, fees are, as noted therein, based on one of the more liberal of the generally utilized large provider schedules. With respect to providers serving Commission clients, the fees proposed in these rules are merely a codification of fees presently being paid by the Commission for the listed services and should result in no economic impact on providers or the clients they serve.

#### Regulatory Flexibility Statement

The proposed repeal and new rules do not impose reporting, recordkeeping or other compliance requirements on small businesses as the term is defined in N.J.S.A. 52:14B-16 et seq. These new rules reflect only procedures, standards, and services as they apply to and benefit the rehabilitation of blind and visually impaired clients of the Commission.

Full text of the proposed repeal may be found in the New Jersey Administrative Code at N.J.A.C. 10:95.

Full text of the proposed new rules follows:

### CHAPTER 91

## ORGANIZATION AND GENERAL POLICY PROVISIONS OF THE COMMISSION FOR THE BLIND AND VISUALLY IMPAIRED

### SUBCHAPTER 1. PURPOSE AND SCOPE OF COMMISSION SERVICES

#### 10:91-1.1 Administration of the Commission

(a) The Commission for the Blind and Visually Impaired (the Commission) is an integral part of the Department of Human Services.

(b) The Commission's entire service delivery system is vested in two Statewide, three regional, one district and two satellite offices. The two Statewide offices offer Statewide vocational and specialized services. They are coordinated out of the Commission's Central Office in Newark. Educational, independent living, prevention and vocational rehabilitation services are provided through the regional, district and satellite offices. The three regions are: Northern, which includes Bergen, Hudson, Morris, Passaic, Sussex and Warren Counties; Central, which includes Essex, Hunterdon, Mercer, Middlesex, Monmouth, Ocean, Somerset and Union Counties; and Southern, which includes Atlantic, Burlington, Camden, Cape May, Cumberland, Gloucester and Salem Counties.

(c) The Commission is coordinated by a Central Office, located in Newark, that includes staff headed by an Executive Director appointed by the Commissioner of Human Services. It provides support functions to the Statewide, regional, district and satellite offices. Some of these functions are policy and procedure development and publication, management and fiscal services, contract and information systems services, monitoring and staff training. Policy and procedural manuals, as they are prepared, shall be available to the public.

(d) The Commission licenses and supervises vending stands at various locations throughout the State, the majority of which are in governmental buildings.

(e) The Commission operates:

1. The Joseph Kohn Rehabilitation Center;
2. The George F. Meyer Instructional Resource Center;
3. The Technical Aids Center; and
4. Camp Marcella, a summer camp for blind and visually impaired children.

#### 10:91-1.2 General purpose and scope of services

(a) The New Jersey Commission for the Blind and Visually Impaired was charged by a 1910 State law, N.J.S.A. 30:6-1, which stated it, "shall provide all means which it deems feasible for ameliorating the condition of the blind."

(b) The Commission defines its mission as promoting eye health and assisting individuals with vision problems to reach their potential by whatever means possible.

(c) The Commission recognizes two major thrusts in carrying out this mission, which are:

1. Working with the community in regard to education and attitudes concerning visual impairment; and
2. Providing client services to persons with vision problems.

(d) For all of its clients, the Commission seeks to provide or insure access to those services which will enable them to obtain their fullest measure of self-reliance, to improve their quality of life, and to be treated with dignity and worth as individuals and fully integrated members of their community.

(e) To achieve this mission, the Commission has established the following goals for itself and for the New Jersey community serving the blind and visually impaired:

1. Prevention Goal: Because 50 percent of all blindness and loss of vision can be prevented or minimized, the Commission shall use its resources to publicize, maximize, coordinate, and increase efforts to conduct programs of education and detection to prevent blindness, to retain or restore vision, and to increase public awareness of the causes and treatment of vision loss; and

2. Independent Living Goal: The Commission shall provide the opportunity to persons who are blind or visually impaired to achieve their maximum level of independence and productive functioning in the most appropriate, least restrictive setting.

#### 10:91-1.3 Purpose and scope of educational services

(a) The primary objective of the Commission's Educational Service Program is to provide those services which allow visually impaired students to participate in all classroom activities. To meet this objective, the Commission shall provide to visually impaired students either the services of itinerant instructors of the blind and partially sighted who visit clients in need of direct instruction at their school and/or home or the services of specialists in the field of providing services to visually impaired, developmentally disabled students who

provide technical assistance to the teachers and parents of these clients.

(b) Those students served by a Commission itinerant instructor are considered to be in need of both instructional (for example, instruction in the use of braille, low vision aids, or adaptive techniques) as well as non-instructional services (for example, consultation with the teacher to suggest ways to fully integrate the student into the classroom program).

(c) The students served by specialists usually require only non-instructional services. Both students served by itinerant instructors of the blind and partially sighted and students served by specialists of the visually impaired and developmentally disabled shall also be provided with accommodative aids, materials and/or equipment through the Meyer Instructional Resource Center (see: N.J.A.C. 10:92).

#### 10:91-1.4 Purpose and scope of allied independent living services

The major objectives of the Commission's independent living services are the provision of services related to the instruction of visually impaired individuals by rehabilitation instructors in techniques for performing activities of daily living; traveling skills by orientation and mobility instructors; and meeting social service needs by social workers. Shopping, meal preparation, general maintenance of the home, walking to the mailbox, reading one's mail, enjoying a hobby, and washing clothes are examples of activities of daily living tasks which people carry out on a routine basis. These tasks are included within that group of activities which are a part of one's daily routine, and which permit people to live independently.

#### 10:91-1.5 Purpose and scope of allied prevention services

(a) The main goal of the programs within the Commission's prevention planning area is to prevent, delay the onset of, and/or stabilize the effects of a visual problem. The objective is to alert individuals and/or their caregivers to the need to seek appropriate eye care. If these individuals cannot afford or have no means of paying for the required treatment, then the agency shall assist such persons either financially or through referral to existing benefit programs.

(b) The Commission includes six programs within its prevention services area. Five of these make available free eye screenings or examinations to members of specific target populations, for example, persons with diabetes, preschool children, persons existing on a low income, and children of migrant laborers. The other program within prevention services makes available medical casework services to both indigent persons in need of vision related medical treatment as well as visually impaired individuals who are in need of either health education, for example, instruction in techniques for self-administration of insulin, and/or low vision services. Through these programs, the Commission is able to provide a rather comprehensive package of prevention services.

#### 10:91-1.6 Purpose and scope of vocational rehabilitation (VR) services

(a) The primary goal of the programs included within vocational rehabilitation (VR) services is to assist visually impaired individuals to obtain and maintain suitable employment. In the vernacular of vocational rehabilitation, someone is rehabilitated when placed into employment. Employment includes both wage earner positions (for example, competitive, sheltered, or self employment), as well as maintaining and managing one's home.

(b) Through vocational rehabilitation services, a client may receive the following services:

1. Counseling and guidance;
2. Diagnostic and evaluative services;
3. Services which are of a restorative nature, for example, surgery or low vision aids;
4. Higher education, vocational and/or adaptive skills training;
5. Daily living expenses while receiving another VR service;
6. Job placement services;
7. Other services such as readers or sign language interpreters; and
8. Services after a person is employed.

#### 10:91-1.7 Legal authority to provide services

(a) The Commission for the Blind and Visually Impaired operates under a variety of State and Federal laws. These include the State legislation which created the Commission and made it a division of the Department of Human Services, as well as the Federal Rehabilitation Act of 1973 as amended, and the Education for All Handicapped Children Act of 1975, as amended.

(b) Pursuant to N.J.S.A. 30:6, the Commission for the Blind and Visually Impaired is mandated to provide services to blind and visually impaired people in order to "ameliorate" their condition. Specifically, the Commission is legally authorized to:

1. Maintain a register of all the blind within the State;
2. Fund and provide vocational training;
3. Pay for medical and surgical equipment;
4. Study the causes for blindness and undertake prevention programs;
5. Administer a vending stand program;
6. Provide instruction and assist in suitable educational placement for blind, visually impaired and multi-handicapped children; and
7. Promote and regulate the sale and distribution of products made by blind and visually impaired persons.

(c) The Rehabilitation Act of 1973 (P.L. 93-112), as amended by the Rehabilitation Act Amendments of 1974 (P.L. 93-516), 1978 (P.L. 95-602), and 1986 (P.L. 99-506) is the Federal statute governing State administration of federally funded vocational rehabilitation services. The provisions of this Act are implemented in 34 CFR Parts 361, 365 and 370.

(d) In the State Plan submitted by the New Jersey Department of Labor, Division of Vocational Rehabilitation Services (DVRS), the Commission is designated the "sole State agency for the Blind" in New Jersey. This designation means that the Commission is the only State agency which is legally authorized to provide vocational rehabilitation services to blind and visually impaired persons.

(e) Because of the Commission's legal authority to provide vocational rehabilitation services to blind and visually impaired persons, DVRS and the Commission share the Federal VR Grant annually allotted to New Jersey. To clarify which agencies will be responsible for which clients, the Commission and DVRS have a written agreement pursuant to 34 CFR 361.5. The most recent DVRS/Commission agreement provides in summary that:

1. Where an individual has central vision of 20/70 or more in the better eye with correction and there is little likelihood that vision is deteriorating, the responsibility for providing rehabilitation services rests with DVRS;

2. Any individual who has an eye problem requiring surgery is considered to have a serious impairment and shall be referred to the Commission by DVRS;

3. Any other individual who DVRS finds has a serious visual problem or a work placement problem because of his or her vision shall be referred to the Commission by DVRS; and

4. Wherever necessary the respective agencies shall consult one another in order to review and clarify the status of the client so that referrals can be expedited to the agency which can better serve him or her.

(f) The Education of All Handicapped Children Act of 1975 (P.L. 94-142), as amended by the Education for All Handicapped Children Act Amendments of 1986 (P.L. 99-457), is the Federal statute guaranteeing handicapped children, ages three through 21, a "free appropriate public education emphasizing special education and related services." The Act provides formula grants to states to fund these services. The provisions of the Act are implemented in 45 CFR Parts 106b, 116b, 121a.

(g) The Education of All Handicapped Children Act and its implementing regulations apply to all agencies having direct or delegated authority for the education of handicapped children regardless of whether they receive funds under the Act. In New Jersey, these agencies include the New Jersey Department of Education, local school districts, State-operated facilities and the Commission.

(h) As a provider of educational services, the Commission also falls under N.J.A.C. 6:28, Special Education. These rules correspond to the Education of All Handicapped Children Act.

## 10:91-1.8 Purpose and scope of the New Jersey blind register

(a) In accordance with N.J.S.A. 30:6-1, the Commission shall prepare and maintain a register of all the blind within the State.

(b) In accordance with N.J.S.A. 30:6-15, the Commission is empowered to make inquiries concerning the causes of blindness and the proportion of cases within the State which is preventable, and it is entitled to receive the cooperation of other State and local government agencies in making these inquiries. The Commission shall publish an annual report, including, but not limited to, incidence and prevalence rates of blind and visually impaired persons in all areas of the State.

## 10:91-1.9 Composition and functions of the Commission's consumer advisory boards

(a) The Commission's consumer advisory boards have been created in order to provide consumers and interested persons the opportunity to evaluate, comment upon and impact on services provided by the Commission. Additionally, the boards review the Commission's administrative policies and procedures and provide input on Commission initiatives. To be eligible for board membership, an individual shall be visually impaired (20/50-1 in the better eye with all possible corrections) or the parent or guardian of a visually impaired person.

(b) Board membership should include representatives of the disabled and minority communities, as well as senior citizens and parents or guardians of below college level students.

(c) The Board(s) shall consist of up to seven members appointed by the Commission's Executive Director and/or the regional or Statewide office managers. There shall be no overrepresentation of existing consumer organizations. There shall be established regional, as well as central, office Boards.

(d) A letter over the Executive Director's and/or the regional or Statewide office manager's signature shall be sent to organized and unorganized blind and visually impaired groups and individuals seeking applicants for membership.

(e) The following persons shall not be eligible for consumer advisory board membership:

1. Paid Commission employees;
2. Paid Commission consultants;
3. Persons employed by an agency under contract with the Commission; and
4. Persons who are members of the immediate household or direct business associates of a person described above or related to a Board member by blood or marriage.

(f) Anyone wishing to apply for board membership shall express that desire in writing to the Executive Director or the appropriate regional or Statewide office manager and request an application. The applicants shall hear from the Executive Director or appropriate manager regarding acceptance or denial of their request within 30 days after returning the application.

(g) Boards shall:

1. Comply with the Open Public Meetings Act, N.J.S.A. 10:4-6 et seq.;
2. Choose one of its members to act as chairperson. The chairperson shall automatically have a seat on the executive director's consumer advisory board, representing the regional board;
3. Meet not less than four times a year; and
4. Determine the location of the meetings.

(h) Board responsibilities are:

1. To serve as advocate and advisor to Commission staff in the development of services to the blind and visually impaired;
2. To review Commission services and related programs;
3. To advise and make recommendations concerning services dealing with the development of policies and procedures within the general directive of the Department of Human Services and any changes affecting services and policies;
4. To review the Commission's Annual State Plan of services;
5. To survey client satisfaction with agency services;
6. To assist in developing regional office budgets;
7. To evaluate program planning and service delivery; and
8. To review and evaluate grant awards priorities.

(i) Terms of office are as follows:

1. Board members may serve for three years;
2. Board members may serve two consecutive terms;
3. Board members shall not be reappointed until two years after their last active term of office; and
4. Vacancies shall be filled within 60 days by the Executive Director and/or regional or Statewide office manager as appropriate.

(j) If an expired term of office is more than 50 percent, a nominee can serve only one additional term of office. If less than 50 percent a nominee can serve two additional terms of office.

(k) The scope of power of Board members is as follows:

1. Board members shall have direct access to the Executive Director and/or regional or Statewide office manager; and
2. Board members shall have access to public documents of the Commission, such as the State Plan, policy manuals and budget.

(l) Board members shall be replaced by the Board if 50 percent or more of scheduled meetings are missed without prior excuse absence.

## 10:91-1.10 Purpose and responsibilities of the Commission's client service representative

(a) The Commission's client service representative shall assist applicants and clients who are not satisfied with Commission service by seeking better and more timely services. The representative intervenes on behalf of the applicants or clients who are having difficulty with the Commission by identifying the problem and by attempting to resolve it.

(b) The client service representative is a client advocate who directs blind or visually impaired persons to appropriate Federal, State or local agencies mandated to help persons who suspect that they are being discriminated against because of their handicap. For example the representative assists clients in contacting the New Jersey Department of the Public Advocate, the United States Office for Civil Rights, the New Jersey Division on Civil Rights, or the New Jersey Department of Labor.

(c) The client services representative can be reached by calling the Commission's toll free number, 1-800-962-1233.

## 10:91-1.11 Request for legal guardianship of a client

Pursuant to the recommendation of the Attorney General's office neither the Commission, nor any staff member of the Commission shall be named legal guardian for any Commission client. If an agency or individual wishes to request guardianship, such request shall be directed to the Commission's Chief of Field Operations. The request shall then be forwarded to the appropriate Department of Human Services division, depending on the nature of the client's disability.

## 10:91-1.12 Definitions

The following words and terms, when used in this Chapter, shall have the following meanings, unless the context clearly indicates otherwise:

"Accommodation" means a process by which a person utilizes alternative techniques to perform vision oriented tasks.

"Active status" means that a person has been found eligible to receive all appropriate Commission services and the person is currently receiving said services.

"Adaptive skills" means those skills which a visually impaired person has learned allowing them to perform tasks that normally involve the utilization of the visual sense.

"Ancillary caseworker" means a Commission staff person who is providing services to a client but is not the client's primary caseworker.

"Applicant" means a person who has completed the agency's application for service form, but has not yet been found either eligible or ineligible for placement into active status.

"Best correction" means the optimal visual acuity which a person can attain after their visual functioning is evaluated by an eye doctor.

"Communicable disease" means any disease which can be acquired as a result of direct contact with someone who has the disease.

"Competitive employment" means a job wherein the person is paid wages and the job is a position which is also available to non-disabled persons.

"Contested case" means an adversary proceeding, including any licensing proceeding, in which the legal rights, duties, obligations, privileges, benefits or other legal relations of specific parties are required by constitutional right or by statute to be determined by an agency by decisions, determinations, or orders, addressed to them or disposing of their interests, after opportunity for an agency hearing (see N.J.S.A. 52:14B-2). The required hearing must be designed to result in an adjudication concerning the rights, duties, obligations, privileges, benefits or other legal relations of specific parties over which there exist disputed questions of fact, law or disposition relating to past, current or proposed activities or interests. Contested cases are not informational nor intended to provide a forum for the expression of public sentiment on proposed agency action or broad policy issues affecting entire industries or large, undefined classes of people.

"Daily living skills" means those skills which a person learns that allows them to perform personal care activities, for example, dressing, washing and shopping.

"Developmentally disabled" means a severe, chronic disability of a person which is attributable to a mental or physical impairment or combination of mental or physical impairment that is manifest before age 22, is likely to continue indefinitely, results in substantial functional limitations in three or more of the following areas of major life activity, that is, self-care, receptive and expressive language, mobility, self-direction, and capacity for independent living or economic self-sufficiency, and reflects the need for a combination and sequence of special interdisciplinary or generic care, treatment or other services which are of life-long or extended duration and are individually planned and coordinated. Developmentally disabled includes, but is not limited to, severe disabilities attributable to mental retardation, autism, cerebral palsy, epilepsy, spina bifida and other neurological impairments where the above criteria are met.

"Eligible" means that a visually impaired person has met the eligibility criteria set forth for the services they wish to receive.

"Field of vision defect" means that the person cannot detect visual stimuli throughout the entire area being observed which normally can be seen without moving the head or eyes. See definition of "legally blind" in this section.

"Homemaker" means a person who performs the major portion of tasks associated with maintaining a home.

"Independent living" means that a person is able to maximize their level of independent and productive functioning in the most appropriate, least restrictive setting.

"Intake" means the process by which the Commission assesses a person's need, desire and eligibility for agency services.

"Last dollar resource" means that the Commission will execute payment for a service only after all other potential payors have been eliminated.

"Legally blind" means central visual acuity that does not exceed 20/200 in the better eye with best correction or fields of vision that are so limited that the widest diameter of visual field subtends an angle no greater than 20.

"Low vision" means reduced visual acuity and/or abnormal visual fields which are the result of a disorder in the visual system.

"Non-contested case" means any hearing offered by an agency for reasons not requiring a contested case proceeding under the statutory definition of contested case.

"Preschool" means that period of time between birth and a child's sixth birthday.

"Primary caseworker" means the Commission staff person who is assigned the responsibility of being the Commission's main representative to an individual client.

"Referral" means that a person or someone on their behalf has contacted the Commission to investigate the availability of services.

"Resident" means a person who is currently residing in New Jersey, or for the purpose of vocational rehabilitation, in the United States and who is either a United States citizen by birth or naturalization or can provide documentation that they have either applied for and/or been granted permanent residence by the Immigration and Naturalization Service.

"Self-employment" means that a person owns and operates their own business.

"Sheltered employment" means that a person is employed within a controlled environment which utilizes work experience and related services to assist the handicapped individual to achieve a more productive vocational status.

"Similar benefit" means any service or financial assistance for the same services from any other source(s).

"Visual acuity" means the measurement of the ability of the eye to perceive the shape of objects in the direct line of vision and to distinguish detail.

"Visual impairment" means that a person identifies themselves as having difficulty reading ordinary newsprint even when wearing glasses.

## SUBCHAPTER 2. ELIGIBILITY STANDARDS FOR COMMISSION SERVICES

### 10:91-2.1 Allied independent living and prevention services

(a) Individuals whose visual acuity is better than 20/70 shall be eligible for certain services, if they have a problem in one or both eyes requiring surgery or treatment if such surgery or treatment would prevent vision loss, as follows:

1. Social caseworker assistance, rehabilitation classes and/or teaching or orientation and mobility instruction provided with the approval of the regional manager;

2. Muscle surgery which may contribute to an overall improvement in vision by enabling both eyes to work in unison even if the surgery neither prevents vision loss nor restores vision. Requests for muscle surgery by individuals with visual acuity of 20/70 or better shall be considered for approval by an allied services supervisor on a case-by-case basis; and

3. Medical casework services.

(b) Individuals shall be eligible for all allied services if their best corrected vision is 20/70 or less in their better eye.

(c) Individuals who have field of vision defects shall be eligible for all allied services (see N.J.A.C. 10:91-1.12).

(d) Individuals shall be ineligible for non-surgery or treatment related services if their best corrected vision is 20/50-1 to 20/69 in their better eye except as outlined in (a) above.

### 10:91-2.2 Education services

(a) Individuals whose best corrected visual acuity is 20/70 or less in their better eye shall be eligible for educational services.

(b) Individuals with field of vision defects shall be eligible for education services (see N.J.A.C. 10:91-1.12).

(c) Individuals with a problem in one or both eyes requiring surgery or treatment with visual acuity better than 20/70 shall be ineligible for educational services.

(d) Individuals whose best correction is between 20/50-1 and 20/69 in their better eye shall be ineligible for educational services.

(e) Education services clients shall meet additional criteria as set forth in N.J.A.C. 10:92.

### 10:91-2.3 Vocational rehabilitation services

(a) Individuals shall be eligible for vocational rehabilitation services if their best corrected vision is 20/50-1 to 20/69 in their better eye and vision is deteriorating and there is a job placement problem because of vision dysfunction.

(b) Individuals whose visual acuity is better than 20/69 shall be eligible for vocational rehabilitation services if there is a problem in one or both eyes requiring surgery or treatment and if there is a job placement problem because of vision dysfunction.

(c) Individuals whose best corrected vision is 20/70 or less in their better eye shall be eligible for vocational rehabilitation services.

(d) Individuals with field of vision defects shall be eligible for vocational rehabilitation services (see N.J.A.C. 10:91-1.12).

(e) Vocational rehabilitation services' clients shall meet additional criteria pursuant to N.J.A.C. 10:95.

(f) To be eligible for the Vending Facility Program, a person shall meet the definition of legal blindness.

### 10:91-2.4 Eye reports

(a) Eye reports shall be completed by ophthalmologists or optometrists and forwarded to the client's primary caseworker at the Commission. The eye report shall include an initial report including

an eligibility classification and treatment recommendation, a report of any follow-up visits, and a post-operative report. Eye reports are necessary as part of the preliminary diagnostic study, to determine eligibility for Commission services, to develop service plans and to monitor the client's visual progress or lack of progress.

(b) The Commission shall request an eye report when the Commission pays for a client's eye examination, when the client pays for an examination, when a new examination is needed, or when a client has not been examined within the past year and a current eye report is considered necessary.

(c) Eye reports shall be filed in the client's case record.

(d) The caseworker's responsibility is to secure the name and address of a client's eye doctor. If a client has no eye doctor, the caseworker shall provide the client with a list of available doctors. If an eye exam has occurred within the past year, the caseworker shall inform the client that the eye report will be requested directly from the eye doctor.

(e) Commission staff cannot recommend specific doctors. Staff will provide a minimum of three doctors' names to clients in close proximity and accessible from a client's residence. The clients may select the doctor of their choice.

#### 10:91-2.5 Residency requirements

(a) New Jersey residents who meet eligibility standards shall be eligible for all Commission services.

(b) Residents of other states who meet the eligibility standards shall be eligible for Commission services as follows:

1. Eligible for orientation and mobility training;
2. Eligible for educational services if they are receiving care at a New Jersey treatment center and the projected length of stay is not more than six months; and
3. Eligible for vocational rehabilitation if they are available to complete the full vocational rehabilitation program including placement in employment.

(c) Resident aliens who meet the eligibility standards shall be eligible for all Commission services.

(d) Non-resident aliens, including people with temporary and student visas, who meet the eligibility standards shall be eligible for Commission services as follows:

1. Eligible for orientation and mobility;
2. Eligible for Educational Services if attending preschool, elementary school or high school; and
3. Equalization services shall be provided to foreign students attending college full time if funds are available and if the Statewide manager approves pursuant to N.J.A.C. 10:95.

#### 10:91-2.6 Other educational standards

(a) The Commission shall provide special instruction and/or related services to certain individuals whose visual dysfunction impedes or may impede their progress in elementary and secondary school.

(b) An applicant for special instruction and/or related services shall meet the following eligibility requirements:

1. As set forth in N.J.A.C. 10:91-2.2 and 2.5;
2. He or she is 21 years of age or younger; and
3. He or she has not completed secondary school.

(c) Assessment and evaluation of the need for Commission services is based upon a determination that an individual meets the visual eligibility standards pursuant to N.J.A.C. 10:91-2.2, following which the Commission shall make a further determination as to a student's eligibility for educational services.

(d) Educational needs related to visual loss shall be reviewed by the Commission with the student, his or her parent or guardian and the local school district study team.

1. If it is determined that the student's visual dysfunction adversely affects his or her academic progress, the Commission shall provide educational services; and

2. If it is determined that the student's visual dysfunction does not adversely affect his or her academic progress, but the individual is eligible for other Commission services, he or she shall be referred to allied services.

#### 10:91-2.7 Other vocational rehabilitation (VR) standards

(a) The primary purpose of a VR eligibility determination shall be to identify those visually impaired persons who may be served with VR funds pursuant to 34 CFR 361.31.

(b) The VR counselor shall have the ultimate responsibility, after advice and consultation with the supervisor, ancillary workers and medical consultants, to determine an individual's:

1. Eligibility for VR services;
2. Eligibility for extended evaluation; and
3. Ineligibility for VR services.

(c) Services to determine eligibility, while the client is in applicant status, shall be provided without regard to economic need.

(d) Illegal aliens present in the United States without legal status shall not be eligible for VR services.

(e) Immigrant aliens admitted for the purpose of permanent residence and who possess a valid alien registration card shall be eligible for VR services.

(f) Non-immigrant aliens are individuals admitted for a particular purpose or time period and are expected to return to their home country upon completion of a specific purpose or time period. Examples include:

1. Visitors for business or pleasure;
2. Crewmen of vessels or aircraft; and
3. Students pursuing a course of study.

(g) Non-immigrant aliens may be eligible for VR services if the individual is available to complete an Individual Written Rehabilitation Plan and the individual's temporary registration card (I-94) would allow the client to become employed.

(h) Eligibility shall be determined without regard to sex, race, age, color, religion, national origin, economic need, or category of disability.

(i) Eligibility criteria are as follows:

1. "Criterion I" means the presence of a physical or mental disability;
2. "Criterion II" means the disability must constitute for that individual a substantial handicap to employment; and
3. "Criterion III" means there is a reasonable expectation that vocational rehabilitation services will benefit the individual in terms of employability.

(j) In all cases of legal blindness, severe visual impairment or where a rapidly progressive visual condition exists, the Commission shall have the responsibility for at least providing an evaluation to determine eligibility regardless of other documented disabilities.

#### 10:91-2.8 Notification of ineligibility for allied and education services

(a) The Commission for the Blind and Visually Impaired shall notify by certified mail an individual, other than a preschool vision screening participant, who applied or was referred for Commission services whenever such an individual has been found to be ineligible for services (see N.J.A.C. 10:91-2.1 and 2.2). The Commission shall send this notice within two weeks of the determination that he or she does not meet basic eligibility criteria and cannot receive services.

(b) A caseworker may initially inform individuals of their ineligibility either in person or by telephone, as long as written notice is mailed within the required two-week period.

(c) The ineligibility notice shall state:

1. The Commission's decision;
2. The basis for the decision;
3. The effective date of the decision; and
4. The methods for appealing the decision.

#### 10:91-2.9 Ineligibility for vocational rehabilitation services

(a) An individual may be determined ineligible for VR services for any of the following reasons:

1. "No disability", which means an individual does not have a visual disability which renders him or her eligible for Commission services, such as TOO MUCH remaining vision;
2. "No vocational handicap", which means a client may have a disability, but does not have a handicap to employment; and/or
3. "No vocational potential", which means a client may have a disability and a vocational handicap, but there is no reasonable

expectation that vocational rehabilitation services will benefit the person in terms of employability. For example:

- i. There is no vocational potential due to the severity of the disability or combination of disabling conditions; or
- ii. There is no vocational potential due to unfavorable medical prognosis.

(b) An individual shall be declared ineligible if he or she fails to meet any of the three eligibility criteria (see N.J.A.C. 10:91-2.7(i));

(c) An ineligibility determination shall be made only after full participation with the individual, parent, guardian, or other representative, or after affording a clear opportunity for such consultation.

(d) The individual shall be notified in writing of an ineligibility decision, including the reasons for the decision, and the means for expressing any dissatisfaction and seeking remedy, including the procedures for an administrative review and fair hearing (see N.J.A.C. 10:91-6.2). The client shall receive a copy of the Certification of Ineligibility and an ineligibility letter.

#### 10:91-2.10 Certificate of ineligibility for vocational rehabilitation services

(a) A certificate of ineligibility shall be maintained in all case records when a client is determined to be ineligible pursuant to N.J.A.C. 10:91-2.9.

(b) No ineligibility certificate shall be needed when clients are closed from referral or applicant status for the following reasons which do not constitute a decision of ineligibility.

1. Client death;
2. Client moves out of State or is impossible to contact after reasonable efforts to do so;
3. Client institutionalized, causing the individual to be unavailable and precluding evaluation, diagnosis, or other essential services for an indefinite or considerable period of time and continuance of an open case would not benefit the individual; and/or
4. Client declines to accept or utilize vocational rehabilitation services after a reasonable effort has been expended to encourage participation.

(c) Appropriate explanations shall be included in the case record when the reason for closure does not fit into any other category and is not related to the eligibility criteria. An individual may decline to participate for reasons determined to be related to the severity of his or her condition, such as emotional problems, which cannot be satisfactorily resolved. The reason for closure is then one of ineligibility instead of unavailability.

#### 10:91-2.11 Presumption of eligibility

(a) A person who meets one of the following criteria will be presumed to be eligible for those services described in N.J.A.C. 10:91-4.1 through 4.3:

1. The person is a former client of the Commissioner who was previously found eligible pursuant to N.J.A.C. 10:91-2.1 through 2.5 and the date on which the person was most recently referred to the Commission is not more than one year after the date on which the person's most recent previous case was closed;

2. The person is a former client of the Commission who was previously found eligible pursuant to N.J.A.C. 10:91-2.1 through 2.5, and whose eye condition, as reported on the most recent eye report the Commission has on file for this person, is one which generally remains stable; or

3. The person is a client of the Division of Developmental Disabilities (DDD) and is being referred to the Commission by a DDD staff person who has documentation on file that the person being referred is visually impaired.

(b) A person shall not be presumed eligible for those Commission services for which there is a financial needs standard (see N.J.A.C. 10:91-3.1 through 3.3).

(c) A person shall not be presumed eligible if in order to receive the services they request must meet the eligibility standards cited in N.J.A.C. 10:91-2.6 and 2.7.

(d) If, at any time, a Commission caseworker receives information which suggests a person who has been presumed eligible may not be eligible, then the caseworker will commence a full eligibility investigation.

### SUBCHAPTER 3. FINANCIAL STANDARD

#### 10:91-3.1 Financial need standard and survey

(a) The financial need standard is a test which shall be used to determine a client's ability to pay for certain services. For those clients who meet the test, the Commission shall provide the cost of these services. For clients who do not meet the test, the standard establishes the level of their responsibility toward the cost of those services. The financial aid provided by the Commission shall supplement rather than replace resources available to a client including similar benefits (see N.J.A.C. 10:91-3.6). The Financial Survey Form and the Financial Participation Worksheet are the documents used to gather and analyze information needed to determine financial eligibility. The exception is college tuition assistance where the Commission utilize the Financial Aid Form which is a standard form utilized by many college applicants for financial aid. The Financial Survey Form and the Financial Participation Worksheet are as follows:

New Jersey Commission for the Blind & Visually Impaired
FINANCIAL SURVEY FORM

1. Client Name \_\_\_\_\_ Social Security # \_\_\_\_\_
2. Counselor \_\_\_\_\_ Date \_\_\_\_\_ mo day yr

FAMILY INCOME

MONTHLY AM'T

3. Gross monthly pay of client (before deductions)
4. Husband/father gross monthly pay (if applicable)
5. Wife/mother gross monthly pay (if applicable)
6. Guardian and/or other contributing family member gross monthly pay
7. Unemployment/temporary disability ins.
8. Workers' Compensation
9. VA pension
10. Supplemental Security Income
11. Social Security Retirement or Disability
12. Welfare
13. Income from property
14. Interest and/or dividend
15. Alimony or child support
16. Other income (specify)
17. GROSS TOTAL MONTHLY CASH INCOME
From all Sources (Total Lines 3 through 16)

DEDUCTIONS FROM INCOME

MONTHLY AM'T

18. Indebtedness
19. College/training costs
20. Medical care/treatment costs per year; less \$1068 =; divided by 12 =
21. Second working parent (= \$167)
22. ALLOWABLE DEDUCTIONS FROM INCOME (Total lines 18 through 21)
23. AVAILABLE INCOME (Line 17 minus Line 22)

LIQUID ASSETS

24. Amount of cash on hand or money in the bank
25. Amount invested in savings bonds, stock, bonds, etc.
26. TOTAL LIQUID ASSETS
27. Total number of persons depending on family income, including client
28. Sources of income verification

Medical Insurance (Check Appropriate Box)

Blue Cross \_\_\_\_\_ Blue Shield \_\_\_\_\_ Rider J or Major Medical \_\_\_\_\_
Medicare \_\_\_\_\_ A \_\_\_\_\_ B \_\_\_\_\_ Medicaid \_\_\_\_\_ Other \_\_\_\_\_ (Specify) \_\_\_\_\_

The information given above is a true statement of my financial condition.

Signature of Client \_\_\_\_\_

A review of the information on this form on the following date(s) indicated that there had not been a change in the client's financial situation.

Date #1 \_\_\_\_\_ Date #2 \_\_\_\_\_ Date #3 \_\_\_\_\_ Date #4 \_\_\_\_\_

FINANCIAL PARTICIPATION WORKSHEET

The client is automatically eligible and the calculation below is unnecessary, if, for the corresponding family size, liquid assets (line 26 on the Financial Survey form) are less than the asset allowance shown in column B and available income (line 23 on the Financial Survey form) is less than the monthly income allowance shown in column E. Otherwise, complete this form on the line corresponding to family size of client. If calculations result in "0" or less, enter "0"

|                       | A                       | B               | C                       | D                          | E                        | F                          | G                              |
|-----------------------|-------------------------|-----------------|-------------------------|----------------------------|--------------------------|----------------------------|--------------------------------|
| Family Size (Line 27) | Liquid Assets (Line 26) | Asset Allowance | Assets Counted (A-B)/12 | Available Income (Line 23) | Monthly Income Allowance | Low Income Deduction (E-D) | Participation Amount (C+D-E-F) |
| 1                     | _____                   | \$ 2,000        | _____                   | _____                      | \$1,024                  | _____                      | _____                          |
| 2                     | _____                   | 4,000           | _____                   | _____                      | 1,351                    | _____                      | _____                          |
| 3                     | _____                   | 6,000           | _____                   | _____                      | 1,718                    | _____                      | _____                          |
| 4                     | _____                   | 8,000           | _____                   | _____                      | 2,046                    | _____                      | _____                          |
| 5                     | _____                   | 10,000          | _____                   | _____                      | 2,454                    | _____                      | _____                          |
| 6                     | _____                   | 12,000          | _____                   | _____                      | 2,761                    | _____                      | _____                          |
| Over 6 (each)         |                         | (+2,000)        |                         |                            | (+144)                   |                            |                                |
| # _____               |                         |                 |                         |                            |                          |                            |                                |

1. Family size times \$2,000.
2. \$2,761 + \$144 for each one above 6 persons.

ANNUAL FINANCIAL CONTRIBUTION ARRANGEMENT: (See: N.J.A.C. 10:91-3.4)

(b) Family income shall include gross wages before deductions, pensions, income from property and trusts, disability payments, interest and dividends, public assistance payments, and any other funds, not including loans, available to a client or legally responsible person. Dividends or interest from savings or insurance policies shall be counted as income. Only the actual contributions made to the family unit by siblings or other individuals living in the home shall be included as income.

(c) Legally responsible persons shall include spouse, parent or guardian. Where a client over age 18 is supported by a parent, guardian, or other responsible persons the full financial resources of the parents, guardians or legally responsible relatives shall be counted in establishing family income.

(d) Liquid assets shall include checking accounts, cash, savings, stocks, and bonds (current market value) or income from trusts available to a client or legally responsible person.

(e) A home occupied by a client as a residence is not counted as a resource. Income from property shall be counted after deducting the cost of operation and maintenance from the gross income received.

(f) Existing insurance policies shall not be counted as a resource but clients are advised to check to see whether they are eligible for disability payments. Disability payments received shall be counted as income at the time they are received.

(g) Personal effects such as personal apparel, jewelry, and household effects shall not be counted as a resource.

(h) Allowable deductions pertains to indebtedness or costs for medical care in excess of \$1,068 per year of college tuitions or other training costs for family members. These shall be deducted from income. Regular payments for indebtedness of an extraordinary nature such as a business loss shall also be considered on a case-by-case basis to be reviewed by the Supervisor.

(i) Low income deduction pertains to clients who derive income from assets and have little or no income from wages or pension payments. Clients as described in this subchapter shall be allowed a low income deduction. This subsection primarily is intended to assist older persons in allowing them to retain assets needed to generate income.

10:91-3.2 Financial need standard applied to allied and education services

(a) The following table indicates the application of the financial need standard to allied and education clients pursuant to N.J.A.C. 10:91-3.1:

| Purchase of:                                | Allied Services                           | Education Services |
|---|---|--------------------|
| Maintenance                                 | yes                                       | no                 |
| Training Equipment                          | not applicable                            | no <sup>1</sup>    |
| Homemaking: Daily Living Aids               | yes (after initial purchase) <sup>2</sup> | no                 |
| Optical or Accessory<br>Low Vision Aids     | no  | no                 |
| Projection or Electronic<br>Low Vision Aids | yes                                       | See N.J.A.C. 10:92 |
| Transportation                              | no  | no                 |
| Hospitalization                             | yes                                       | yes                |
| Surgery and Treatment                       | yes                                       | yes                |
| Diagnostic Evaluations                      | no  | no                 |
| Prosthetics                                 | yes                                       | yes                |
| Eye Glasses and Lenses                      | no  | no                 |
| Textbooks and Materials                     | no  | no                 |
| Equalization Services                       | no  | no                 |

<sup>1</sup>High cost equipment is provided on a loan basis; and

<sup>2</sup>The financial need standard does not apply to the initial purchase, but does apply to any subsequent purchases.

10:91-3.3 Financial need standard applied to vocational rehabilitation services

(a) Services not subject to the needs test standard are as follows:

1. The first \$10,000 spent on adaptive equipment;
2. Ancillary services provided by Commission staff including rehabilitation teaching, orientation and mobility, eye health nurse and social work services, etc.;
3. All diagnostic and evaluative assessment services while the client is an applicant or is being evaluated to determine eligible for VR services, including medical, psychological and vocational assessment;

4. Eye glasses and lenses;
  5. Costs incurred for any client attending the Joseph Kohn Rehabilitation Center for tuition, transportation, maintenance, or room and board while in any phase of a client's vocational rehabilitation program;
  6. Loan of training or other equipment;
  7. Optical or accessory low vision aids;
  8. Low vision examination for initial evaluation and up to three follow-up visits;
  9. Initial purchases of homemaking aids and aids to daily living;
  10. Maintenance and evaluation costs for a client attending any type of diagnostic or evaluation program while in work adjustment or a basic skill training program at a rehabilitation facility, including the Joseph Kohn Rehabilitation Center;
  11. On-the-job training, although it is considered to be a training program;
  12. Technical Aids Center approved training equipment which remains the property of the Commission;
  13. Transportation for work adjustment and basic skills training at a rehabilitation facility, including the Joseph Kohn Rehabilitation Center;
  14. Visits to and from a doctor's office or hospital in order to determine eligibility while undergoing evaluation for VR services; and
  15. Vocational training for work adjustment and basic skills at a rehabilitation facility including the Joseph Kohn Rehabilitation Center.
- (b) Services subject to the needs test standards are as follows:
1. All purchases of adaptive equipment above the first \$10,000 spent;
  2. Tuition costs for college training. This includes graduate, undergraduate, and two year college programs;
  3. Projection or electronic low vision aids and devices, and follow-up visits;
  4. Homemaking aids and aids to daily living subsequent to the initial purchase;
  5. All maintenance costs not designated as non-needs test items;
  6. Medical devices and equipment such as hearing aids, prosthetic devices;
  7. All placement equipment purchases. When adaptive equipment is purchased for a client as part of the start-up costs of a small business and the total start-up costs are \$10,000 or less, the needs standard does not apply to the purchase of that adaptive equipment (see small business enterprise program, N.J.A.C. 10:95);
  8. Medical costs for physical and mental restoration;
  9. Telecommunication and technological aids and devices including Optacon, CCTV, Versabril, electronic guiding devices, etc.;
  10. All training equipment except that purchased relative to work adjustment training (see Training and vocational programs, N.J.A.C. 10:95);
  11. All transportation costs not designated as non-needs test items; and
  12. All other vocational training costs not designated as non-needs test items.

#### 10:91-3.4 Financial participation by clients

- (a) Participation by a client in the cost of services subject to financial need shall be required up to the calculated participation amount and represents the maximum amount he or she shall be expected to contribute.
- (b) The client's financial participation amount shall be applied to services authorized in the one year period from the date on which the financial participation amount was determined except for instances in which there is a change in income or resources during that period of time.
- (c) The client and the primary caseworker shall mutually agree upon the financial participation arrangement, which shall be documented in the case file. Payments by the client shall be made directly to the vendor. Clients shall be expected to participate up to the calculated participation amounts as first dollar payments. Whenever the client is to participate by contributing a specific amount to

the cost of service, and this is documented on the financial participation worksheet:

1. The caseworker shall prepare an authorization for the Commission's share of the cost; and
2. The copy of the authorization sent to the vendor shall be accompanied by a letter indicating the participation arrangement that has been made with the client. A copy of that letter shall be sent to the client.

(d) The Financial Needs Survey shall be reviewed annually and a new one prepared if there is a change in income or resources.

#### 10:91-3.5 Financial survey form

(a) A financial survey form shall be completed for each new and readmitted client at the time of the first authorization for any services subject to financial need. The client supplies the information and the primary caseworker completes the form.

(b) Survey forms shall not be mailed to clients for completion.

(c) Income shall be verified by pay stubs, or check stubs from pensions or benefits. The caseworker may request the previous year's income tax forms to identify any additional income or to verify the number of individuals reported as dependent on family income. Dependent refers to the total number of individuals dependent on family income, consistent with what is reported on IRS income tax forms.

(d) The client or parents shall be told that the financial survey form and financial participation worksheet shall become part of the client's confidential case record.

(e) Client or parent refusal to provide financial information or to sign the financial survey form shall be noted in the client's case record.

(f) A copy of the completed survey shall be offered to the client, and mailed if requested.

#### 10:91-3.6 Commission as last dollar resource

(a) The concept of similar benefits means that the Commission is the last dollar resource for the purchase of services.

1. "Similar benefits" refers to any service or financial assistance available to visually handicapped persons from a resource other than the Commission. All clients shall be required to use or apply for similar benefits for which they are eligible in order to cover, in whole or in part, the cost of services unless this will cause a significant delay in the provision of services.

2. Similar benefits examples are as follows:

- i. An employer provides placement equipment on the basis of "reasonable accommodation"; and
- ii. Provision of textbooks and materials such as regular print texts and Recordings for the Blind tapes.

(b) Similar benefits shall include the utilization of community resources that may provide financial assistance, benefits, or services to a client.

### SUBCHAPTER 4. DESCRIPTION OF SERVICES

#### 10:91-4.1 Services available to all New Jersey residents

- (a) The following services are available to all New Jersey residents:
1. The 800 Unit provides counseling and guidance services, outreach, information and referral services and processes service applications for anyone contacting the Commission's toll free number (1-800-962-1233). This service is staffed between the hours of 9:00 A.M. and 5:00 P.M., Monday through Friday. Persons contacting the Commission after working hours or on weekends and holidays may leave messages on a tape system. Follow-ups shall be made on all inquiries;
  2. The diabetic eye disease detection program promotes the early detection and monitoring of retinal and other ocular changes in known diabetics (see N.J.A.C. 10:94);
  3. The pre-school vision screening program provides visual acuity and muscle imbalance screening to preschool and kindergarten children, to detect symptoms of amblyopia and other eye conditions that may cause visual impairment or visual loss (see N.J.A.C. 10:94);
  4. The glaucoma detection program (Eye Health Week follow-up) provides follow-up for glaucoma suspects and others individually referred from screening during Eye Health Week which is sponsored by the Medical Society of New Jersey (see N.J.A.C. 10:94);

5. The mobile eye examination units provide eye examinations to individuals for whom eye care is unavailable or available on a limited basis at sites such as housing projects, senior citizens centers, nursing homes, institutions, and facilities for the handicapped (see N.J.A.C. 10:94); and

6. The migrant eye examination program provides eye examinations and follow-up service in conjunction with the New Jersey Department of Education. Service is provided to children of migrant laborers who are attending schools or who are in the preschool handicapped program (see N.J.A.C. 10:94).

#### 10:91-4.2 Services available to all applicants

(a) Vision related medical diagnostic services are available to all applicants as follows:

1. An ophthalmological exam, that is, an initial vision evaluation performed by an ophthalmologist including provision of a report which contains the physician's definitive diagnosis, prognosis, recommendations and classification;

2. An optometric exam, that is, an initial vision evaluation performed by an optometrist including provision of a report and classification; and

3. Evaluation by other vision specialists, such as, an examination by a corneal specialist, neuro-ophthalmologist, retinal specialist, ocular plastic specialist, or pediatric ophthalmologist.

(b) Non-vision related medical diagnostic services are available to all applicants as follows:

1. A general medical examination, that is, an examination performed by an internist, pediatrician or family practitioner with the objective of determining general health status; and

2. An otological exam, that is, an evaluation performed by an otologist which includes a hearing evaluation, detection of abnormalities of the ear canal or ear drum, recommendations for medical/surgical treatment and/or a hearing aid evaluation.

(c) Skills assessment services are available to all applicants as follows:

1. A daily living skills evaluation, that is, an assessment whose outcome is a written report which delineates strengths, weaknesses and needs relative to a client's ability to perform personal management tasks (for example, grooming, cooking);

2. A communication skills evaluation, that is, an assessment whose outcome is a written report which delineates strengths, weaknesses and needs relative to a client's ability to perform reading, writing, listening or other tasks related to receiving or giving information;

3. An orientation and mobility evaluation, that is, an assessment whose outcome is a written report which delineates strengths, weaknesses and needs relative to a client's ability to establish position in and relationship to objects in the environment and to move from one location to another;

4. A functional vision evaluation, that is, an assessment whose outcome is a written report which delineates an individual's strengths, weaknesses and needs relative to a client's ability to use residual vision;

5. An educational skills evaluation, that is, an assessment whose outcome is a written report which delineates strengths, weaknesses and needs relative to a client's ability to perform academic tasks (for example, using textbooks, taking tests);

6. An eye health skills evaluation, that is, an assessment whose outcome is a written report which delineates an individual's strengths, weaknesses and needs relative to a client's ability to secure or carry out the appropriate treatment for an eye condition; and

7. An evaluation by a social worker, that is, an assessment whose outcome is a written report which delineates an individual's needs relative to housing, health care, nutrition, adequate income, family and social supports.

(d) Costs related to diagnostic and evaluation services as specified in (a) through (c) above are available to all applicants as follows:

1. Transportation, that is, expenditures for transporting clients, and their escorts or attendants, if necessary, incidental to the provision of diagnostic services, including costs of travel and subsistence (or per diem allowance in lieu of subsistence) while in transit; and

2. Other related costs, that is, payment for food or shelter incidental to the provision of diagnostic services.

#### 10:91-4.3 Services available to all eligible clients

(a) Once a determination of eligibility has been made by the Commission the client may receive appropriate services as specified in (b) through (q) below.

(b) Vision related medical diagnostics as follows:

1. A low vision exam, that is, an evaluation which has as its objective a prescription of low vision aids and instruction/training programs to enhance the visual performance of clients with low vision;

2. Vision related diagnostic procedures, that is, ultrasound of the eye (biometry), fluorescein angiogram, electroretinogram (ERG), endothelial cell count, fundus photography, visually-evoked response; and

3. Evaluation by other vision specialist (see N.J.A.C. 10:91-4.2 (a) 3).

(c) Non-vision related medical diagnostics as follows:

1. Audiological exam, that is, an audiogram (hearing test) performed by an audiologist; and

2. A psychiatric evaluation, that is, an initial mental status examination provided by a psychiatrist in a face-to-face interview which includes a comprehensive history and evaluation of pertinent diagnostic information necessary to arrive at a diagnosis and treatment plan and recommendation for treatment or further diagnostic studies or consultation.

(d) Psychological diagnostics as follows:

1. Evaluation/testing by a psychologist, that is, an assessment which includes Weschler Intelligence Scale or its equivalent, and tests in the following areas as needed: auditory, visual and visual motor, language, gross motor, personality and adjustment.

(e) Skills assessment at the Joseph Kohn Rehabilitation Center in a program of assessment and incidental instruction for clients who travel to and from the center on a daily basis, or who reside at the center, whose outcome is a written report which delineates the strengths, weaknesses, and needs relative to the client's ability to perform tasks associated with personal communication, orientation and mobility, arts and crafts, and industrial arts as well as the outcome of a vocational assessment of the client.

(f) Vision related restorative treatment by low vision specialists for services other than evaluations. Services are provided or supervised by a medical practitioner and are related to lens fitting and/or follow-up visits.

(g) Non-vision related restorative treatment as follows:

1. Services by a psychiatrist, that is, the provision of ongoing treatment including psychotherapy and medication management;

2. Services by a psychologist, that is, group and individual psychotherapy, marriage and family counseling; and

3. Services by other psychotherapist, that is, group and individual psychotherapy by a certified marriage and family counselor or clinical social worker.

(h) Provision of prosthetics and aids as follows:

1. A low vision aid for distance task, that is, an optical device used for observing objects, persons or other visual stimuli which are over five feet away from the user;

2. A low vision aid for near task (other than CCTV), that is, an optical device used for observing printed materials such as books, menus, etc.;

3. A closed circuit television (CCTV), that is, an optical device which utilizes a camera in conjunction with a monitor in order to magnify printed material;

4. Standard eyeglasses, that is, an optical device which consists of a frame and corrective lenses; and

5. Bifocal eyeglasses, that is, spectacles which contain lenses which correct for both a distance and near vision problem.

(i) Provision of training materials or equipment as follows:

1. Orientation and mobility aids, that is, materials and/or adaptive devices designed to help a blind or visually impaired person accommodate to vision loss when moving from one place to another or when establishing spatial position within the environment; and

2. Activities of daily living aids, that is, materials and/or adaptive devices designed to assist a blind or visually impaired person accommodate to vision loss when performing personal management tasks, for example, cooking, shopping, dressing.

(j) Skills acquisition instruction as follows:

1. Communication skills, that is, instruction whose purpose is to help clients acquire skills or other tasks related to receiving or giving information;

2. Use and care of low vision aids, that is, instruction whose purpose is to help clients acquire skills or concepts which will enable them to maintain and use optical or electronic devices designed to enhance low vision;

3. Use of other specialized aids, that is, instruction whose purpose is to help clients acquire skills or concepts which will enable them to maintain and use adaptive materials or devices (see N.J.A.C. 10:91-4.3(i));

4. Health maintenance, that is, instruction whose purpose is to help clients acquire skills or concepts which will enable them to perform tasks associated with maintaining adequate health care;

5. Techniques for accomplishing activities of daily living, that is, instruction whose purpose is to help clients acquire skills or concepts which will enable them to perform personal management tasks;

6. Orientation and mobility techniques, that is, instruction whose purpose is to help clients acquire skills or concepts which will enable them to establish spatial position within the environment and to move from one location to another, for example, home to work, home to school;

7. Methods of caring for the eye, that is, instruction whose purpose is to help clients acquire skills or concepts which will enable them to maintain proper eye care;

8. Use of residual vision, that is, instruction whose purpose is to help clients acquire skills or concepts which will enable them to make maximum use of their visual capabilities;

9. Social worker intervention, that is, instruction and/or other services provided or arranged by a social worker which address socioeconomic, medical, housing, recreational, and/or other needs of a client; and

10. Joseph Kohn Rehabilitation Center (JKRC) training program for commuters or residents means a program of instruction whose purpose is to provide clients who travel to and from the center on a daily basis or who reside at the center with the opportunity to acquire skills which are needed to perform specific occupations, for example, operator of a vending facility or clerical professions.

(k) Related costs training as follows:

1. Transportation, that is, expenditures for transporting a client, and escorts or attendants as necessary, incidental to the provision of training services, including costs of travel and subsistence (or per diem allowance in lieu of subsistence) while in transit; and

2. Other related costs, that is payments for training services that cannot be properly classified under any other category.

(l) Room and board payments for training at the Joseph Kohn Rehabilitation Center, that is, room and board expenses in connection with the center.

(m) Other maintenance costs, that is, food, shelter, rent, clothing and other subsistence expenses not included within room and board payments.

(n) Training related to services to families as follows:

1. Psychiatric and/or psychological service to a member(s) of a client's immediate family (see N.J.A.C. 10:91-4.3(g));

2. Counseling services to a member(s) of a client's family by Commission staff;

3. Medical consultation to a member(s) of a client's family, that is, the provision of information to family members to help them understand the needs of the handicapped individual;

4. Training/Instruction of a member(s) of a client's family, that is, the provision of services in order to prepare a family member to assist a handicapped individual in a program of independent living skills and to adapt to new or altered methods of home management and/or the provision of child care where such facilities are lacking; and

5. Other services to families, that is, any other service or commodity not listed above which is provided to a member of the client's family so that the client's service plan goals might be accomplished.

(o) Provider service programs to meet the special needs of Commission clients (see N.J.A.C. 10:91-5.6).

(p) Special services request as follows:

1. The Commission for the Blind and Visually Impaired, in coordination with other New Jersey state agencies, provides certain special services to those of its clients who are legally blind.

i. Persons who are not legally blind, but whose best corrected visual acuity is 20/50-1 shall be eligible for issuance of a State of New Jersey Division of Motor Vehicles Identification card; and

2. Eligible Commission clients may request the following special services:

i. Division of Motor Vehicles identification card;

ii. Fishing license;

iii. Income tax certification letter;

iv. Transit Reduced Fare Program;

v. Guide transportation pass;

vi. Theater identification card;

vii. Park forest, or reservation (free) admission pass; and

viii. Handicapped parking placard.

(q) Telephone directory assistance 411 exemption as follows:

1. Individuals whose impairment makes it impossible to use a telephone directory shall be allowed an exemption for directory assistance charges for calls made from their homes. These individuals also may obtain New Jersey Bell Calling Cards to make directory assistance calls from other locations;

2. Eligibility standard, that is, an individual classified as legally blind after all possible correction shall be eligible for an exemption from directory assistance charges; and

3. Application procedures are as follows:

i. Eligible individuals in active status with the Commission may obtain from their caseworker application forms for exemption from directory assistance charges. Caseworkers shall assist the clients in filing the exemption form, if necessary; and

ii. Clients whose cases are closed may telephone the Commission by calling 1-800-962-1233 to request an exemption from directory assistance charges. The 800 Number Operator processes the request by conducting a computer search to verify the existence of an acceptable record of legal blindness, entering on an application form that the individual's entitlement to the exemption is verified by the Commission for the Blind and Visually Impaired, 1100 Raymond Boulevard, Newark, NJ 07102, and mailing the application form to the client for further processing.

10.91-4.4 Additional services available to applicants and/or eligible clients

(a) In addition to services specified in N.J.A.C. 10:91-4.1 through 4.3, services may be made available to clients, as described in (b) through (i) below, when determined to be appropriate to a client's individual needs and based on the judgement and recommendation of a qualified professional, such as, a physician, psychologist or learning disability specialist.

(b) Educational services as follows:

1. Psychological diagnostics:

i. Learning disabilities evaluation, that is, an examination by a neuropsychologist or other learning disabilities specialist which include informal tests and observational measures, standard psychological tests and neuropsychological tests and which is designed to detect disorders of the cognitive processes involved in understanding, perceiving and/or using language or concepts that are spoken.

2. Skills assessment:

i. Camp Marcella provides one or two weeks residential summer camp experience for visually handicapped children.

3. Provision of training materials or equipment:

i. Educational aids, that is, materials and/or adaptive devices which are designed to help a blind or visually impaired person accommodate to vision loss when performing academic tasks.

4. Tuition payment:

i. Specialized school, that is, payment for attendance at residential schools for the deaf-blind;

- ii. Nursery or day schools; and
- iii. Day camp, that is, payment to an organization which operates a program of recreational activities.
- 5. Skills acquisition instruction:
  - i. Methods of accomplishing educational tasks, that is, instruction whose purpose is to help clients acquire skills or concepts which will enable them to perform academically related tasks; and
  - ii. Physical education or recreation skills, that is, instruction whose purpose is to help clients acquire skills or concepts which will enable them to participate in sports and/or leisure activities.
- 6. Room and board payments:
  - i. For all other training, that is, any room and board cost; and
- 7. Other services:
  - i. Reader service, that is, payment to a person under the supervision of a Commission client who reads printed material to and/or writes what is dictated by the client. Reader service is equivalent to amanuensis service.
- (c) Allied prevention services as follows:
  - 1. Vision related restorative treatment:
    - i. Treatment to the eyelids, that is, services provided or supervised by a medical practitioner which are related to procedures involving the eye's lid.
    - ii. Treatment of the lacrimal system, that is, services provided or supervised by a medical practitioner relating to the tear duct and tearing;
    - iii. Treatment of the conjunctiva, that is, services provided or supervised by a medical practitioner which are related to conjunctivitis or removal of the pterygium;
    - iv. Procedures related to repair of the cornea, that is, services provided or supervised by a medical practitioner which are related to an injury to the cornea including lacerations;
    - v. Procedures related to a corneal transplant, that is, services provided or supervised by a medical practitioner which involves the removal and subsequent replacement of the eye's cornea;
    - vi. Other treatment of the cornea, that is, services provided by a medical practitioner which are related to the removal of a foreign body, treatment of corneal abrasions, scraping of an ulcer on the cornea, etc;
    - vii. Treatment of a condition of the iris, ciliary body, sclera, and anterior chamber, that is, services provided or supervised by a medical practitioner which are related to such treatment;
    - viii. Treatment related to cataract extraction, that is, services provided or supervised by a medical practitioner which are related to the removal of the eye's natural lens;
    - ix. Treatment related to insertion of prosthetic lens, that is, services provided or supervised by a medical practitioner which relate to the removal of the eye's natural lens and subsequent implantation of an artificial one;
    - x. Treatment related to the repair of retinal detachment/tear, that is, services provided or supervised by a medical practitioner which are related to a retinal detachment or tear;
    - xi. Other treatment related to the retina, choroid or posterior chamber, that is, services provided or supervised by a medical practitioner which are related to the treatment of inflammations or tumors;
    - xii. Treatment related to vitrectomy, that is, services provided or supervised by a medical practitioner which are related to the removal of the eye's vitreous;
    - xiii. Treatment related to the extra-ocular muscle, that is, services provided or supervised by a medical practitioner which are related to procedures involving eye muscles;
    - xiv. Treatment related to the eyeball, that is, services provided or supervised by a medical practitioner which are related to a medical procedure involving the eyeball (that is, enucleation);
    - xv. Contact lens specialists for services other than evaluation, that is, services provided or supervised by a medical practitioner which are related to lens fitting and/or follow-up visits;
    - xvi. An assistant surgeon in connection with vision-related treatment; and
    - xvii. An anesthesiologist for vision related treatment, that is, medical practitioner who is certified to administer anesthesia during a surgical procedure related to the eye.

- 2. Non-vision related restorative treatment:
  - i. Services Diabetologist, that is, an evaluation by a diabetes specialist.
- 3. Provision of prosthetics and aids:
  - i. An intraocular lens, that is, an optical device which is implanted in the eye as a replacement for the eye's natural lens;
  - ii. Contact lenses, that is, an optical device which rests directly on the eyeball whose purpose is to correct a refractive error;
  - iii. An ocular prosthetic, that is, a device which occupies the eye socket after an eye has been enucleated; and
  - iv. Eyeglasses for aphakia, that is, lenses which mount on the face in front of the eyes in order to correct the refractive error caused by the removal of the eye's natural lens.
- 4. Other vision related medical services:
  - i. Treatment related drugs or supplies, that is, payment for prescribed medications, biologicals, or supplies which are incident to the restorative services;
  - ii. In-patient hospitalization, that is, payment to a hospital for services provided to a client who has been or will be admitted to a hospital. Clients who will be having "same day surgery" are admitted to the hospital as patients;
  - iii. Out-patient hospitalization, that is, payment for hospital care which is provided to a client who has not been admitted to the hospital facilities at which the treatment occurs;
  - iv. Convalescent care, that is payment to a convalescent or nursing home or nursing services organization for clients to purchase room, board, nursing home care and other services provided by said facility or organization;
  - v. X-rays, that is, a diagnostic procedure wherein Roentgen ray photographs of bodily parts are made and then interpreted by a medical professional;
  - vi. Lab tests, that is, diagnostic and/or pathology procedures such as urinalysis; and
  - vii. Pre-admission testing, that is, an examination performed prior to same-day surgery or in-patient hospitalization which includes blood pressure measurement, lab work/tests, etc.
- 5. Other vision restoration related services:
  - i. Transportation, that is, expenditures for transporting a client, and their escorts or attendants, if necessary, incidental to the provision of restoration services, including costs of travel and subsistence (or per diem allowance in lieu of subsistence) while in transit; and
  - ii. Other related cost, that is, payment for restoration services that cannot be properly classified under any other category.
- 6. Provision of training materials or equipment:
  - i. Health aids, that is, materials and/or adaptive devices which are designed to help a blind or visually impaired person accommodate to vision loss when performing health maintenance tasks, for example, injecting insulin or administering medication.
- (d) Vocational rehabilitation (VR) services as follows:
  - 1. Non-vision related medical diagnostics:
    - i. A dental exam, that is, an evaluation performed or supervised by a dentist whose purpose is to detect maxillofacial problems and/or diseases of the teeth and gums;
    - ii. A diabetologist exam, that is, an evaluation by a diabetes specialist;
    - iii. A gastro-intestinal exam, that is, an evaluation performed by a specialist in diseases of the stomach and intestinal tract;
    - iv. A cardio-vascular examination, that is, an evaluation performed by a specialist in circulatory disorders of the heart and blood vessels;
    - v. A proctological exam, that is, an evaluation performed by a proctologist;
    - vi. A chiropractic exam, that is, an evaluation performed by a chiropractor;
    - vii. X-rays (see (c)4v above);
    - viii. Lab tests (see (c)4vi above);
    - ix. An orthopedic exam, that is, an evaluation by a specialist in spine, joint and bone diseases and conditions;
    - x. A neurological exam, that is, an evaluation by a specialist in central nervous systems disturbances.

- xi. Evaluation by other medical specialists, that is, all other evaluations by a specialist not listed separately in this series;
- xii. A speech/hearing evaluation, that is, an evaluation by a speech pathologist including an audiogram designed to detect impairment in speech and hearing;
- xiii. A surgical evaluation, that is, an examination or pre-operative consultation by the practitioner who will be performing the surgery;
- xiv. A respiratory exam, that is, an evaluation by a pulmonary lung specialist.
- xv. A dermatological exam, that is, an evaluation by a skin specialist;
- xvi. An oncological exam, that is, an evaluation by a cancer specialist;
- xvii. A genito-urinary exam, that is, an examination performed by a urologist or gynecologist; and
- xviii. An otorhinolaryngological exam, that is, evaluation by an ear, nose and throat specialist.
- 2. Psychological diagnostics:
  - i. Psychometric testing, that is, an assessment of a person's vocational skills, career preferences and performance.
- 3. Skills assessment:
  - i. A vocational/pre-vocational evaluation, that is, an assessment whose outcome is a written report which delineates strengths, weaknesses and needs relative to a client's ability to perform tasks associated with a particular job or to carry out job seeking activities;
  - ii. A career awareness evaluation, that is, an assessment whose outcome is a written report which delineates an individual's level of knowledge relative to current employment trends, level of ability to make informed career choices, and level of ability to make informed choices relative to the need for post-secondary education and/or the appropriate post-secondary course of study;
  - iii. A self-employment evaluation, that is, an assessment whose outcome is both a written report which delineates an individual's potential for self-employment as well as the probability of whether the individual's self-employment goal will succeed; and
  - iv. A home products evaluation, that is, an assessment whose outcome is a written report which delineates a homebound individual's potential for self-employment.
- 4. Vision related restorative treatment (see (c)1 above);
- 5. Non-vision related restorative treatment:
  - i. Speech/hearing therapist services, that is, provision of training necessary to enable persons with speech/hearing impairments to develop useful communication skills;
  - ii. Physical therapist services, that is, provision of treatment necessary to overcome disabilities which interfere with activities of daily living/physical limitations of movement and bodily functions. Treatment can include the application of a range of therapeutic modalities such as exercise, gait training, massage, heat, water, light and electricity;
  - iii. Dental services, that is, provision of routine dental health care including cleaning, tooth extraction, filling of cavities, and replacement with artificial materials;
  - iv. Occupational therapist services, that is, provision of treatment directed toward an individual's participation in selected tasks designed to restore, reinforce, and enhance performance; facilitate learning of those skills and functions essential for adaptation and productivity or which diminish or correct pathology, and to promote and maintain health. Its fundamental concern is the development and maintenance of the capacity through the life span to perform those tasks and roles essential to productive living;
  - v. Gastro-intestinal specialist services (see (d)1iii above);
  - vi. Cardio-vascular specialist services (see (d)1iv above);
  - vii. Orthopedist services (see (d)1ix above);
  - viii. Neurologist services (see (d)1x above);
  - ix. Chiropractor services (see (d)1vi above);
  - x. E.N.T. specialist services (see (d)1xviii above);
  - xi. An assistant surgeon involved with on-vision related surgery;
  - xii. An anesthesiologist involved in non-vision related surgery;
  - xiii. Diabetologist services (see (c)2 above); and
  - xiv. Services of other specialists, that is, all other services other than evaluation provided by specialists not listed separately in this series;

- 6. Provision of prosthetics and aids (see (c)3 above);
- 7. Other vision related medical services (see (c)4 above);
- 8. Other restoration related services (vision or non-vision) (see (c)5 above);
- 9. Provision of training or equipment:
  - i. Vocational aids, that is, materials and/or adaptive devices which are designed to help a blind or visually impaired person accommodate to vision loss when performing job related tasks, for example, reading a computer monitor;
- 10. Tuition payment:
  - i. College or university;
  - ii. Vocational training, that is, payment for specific job related instruction which is provided by an agency, school or individual;
  - iii. Adjustment training, that is, payment for pre-vocational type activities which promote an awareness of and healthy adjustment to the work environment and which provides clients with direct experiences of various types of work; and
  - iv. On-the-job training subsidies, that is, payment to an employer to support vocational training provided to a client by the employer;
- 11. Job readiness training:
  - i. Career awareness training, that is, provision of pre-employment counseling and guidance related to occupational choices and career decisions;
  - ii. Job clubs, that is, counseling and guidance provided on a group basis to help clients learn the basic tools for obtaining employment and to offer peer support during the job-hunting process; and
  - iii. Job seeking skills, that is, counseling and guidance relating to resume preparations, dress and personal appearance, filling out applications and writing letters, applying for a job or responding to a job ad, interview techniques and taking employment tests;
- 12. Room and board payments:
  - i. For restoration services including hospitalization, that is expenses incurred for restoration services a client receives while away from home;
  - ii. For placement, that is, expenses incurred by a client in conjunction with job interviews or employment up to the receipt of client's initial pay check; and
  - iii. For all other training, that is, any room and board cost not listed in this paragraph.
- 13. Training related to services to families:
  - i. Child care expenses incurred so that client may receive services.
- 14. Job placement:
  - i. Occupational exploration, that is, the process by which jobs are analyzed and, if needed, modified, and the client, employers, and supervisors are consulted, advised, and trained;
  - ii. Business Enterprise Program consultation, that is, the provision of assistance to either a vending stand operator on issues related to managing a vending stand or a person who has recently started his or her own business; and
  - iii. Placement tools or equipment, that is, payment for licenses, tools or equipment necessary to accomplish job functions, advertising, initial business insurance premium, initial stock and other start up expenses;
- 15. Other services:
  - i. Reader service (see (b)7i above);
  - ii. Services of an interpreter for the deaf, that is, payment to a person who acts as a translator for someone who communicates using a sign language such as AMSLAN; and
  - iii. Interpreter service, that is, payment to a person who acts as a translator for someone who communicates in a language other than English.
- (e) The Vending Facility Program is a VR service program which evaluates, trains and places a person who is legally blind into employment as an operator of a vending facility. The Commission is empowered by the Federal Randolph-Sheppard Act, as amended, as the sole State licensing agency to certify and license blind individuals to operate vending facilities on Federal and non-Federal property in the State (see N.J.A.C. 10:97).
- (f) The Small Business Enterprise Program evaluates VR clients to determine their suitability to own and operate an independent business enterprise that is not part of the vending facility program. (see N.J.A.C. 10:95).

(g) The Homebound Small Business Enterprise Program provides services to VR clients who have a goal of owning and operating a home-based business (see N.J.A.C. 10:95).

(h) The Home Products Program evaluates the work potential of VR clients in the home and provides business consultation and other services to train clients in the production of products in the home. These products are sold to the public at various sites throughout the State (see N.J.A.C. 10:96 and 10:95).

(i) Client Assistance Fund provisions are as follows:

1. The Client Assistance Fund shall be available to assist eligible clients of the Commission in meeting certain financial emergencies. These emergencies may include the following:

i. A client's specific, documented needs have not been met because money budgeted for the client by one or more Commission programs has not been provided for in a timely fashion;

ii. A client faces deprivation of a vital aspect of his or her life, for example, health care, shelter or social needs; and

iii. A client needs the funds to help overcome another immediate crisis or short-term hardship.

2. A client shall request money from the Client Assistance Fund only when the client's family has no readily available money, the client can not obtain funds from any other public or private sources and there are no other financial resources available to the client;

3. The Client Assistance Fund shall not impose a ceiling on the amount made available to a qualifying client. No limitation shall be placed on the number of requests for funds that a qualifying client may make; and

4. Types of allocations (loans or grants) are as follows:

i. Monies from the Client Assistance Fund shall be provided to eligible clients on a loan basis. Exact payment terms and any other relevant terms shall be stipulated to the client orally and in writing before the funds are issued. The client shall sign a standard promissory note which specifies the terms of the loan agreement. Examples of repayment terms are: the client agrees to repay the Client Assistance Fund as soon as he or she receives a social security check to replace the one that was lost; or the client's regular income is sufficient to allow repayment to the client assistance fund without hardship at a minimum rate of \$25.00 monthly; and

ii. Client assistance funds not allocated specifically as loans shall be disbursed as grants. Repayment of grants shall not be required.

## SUBCHAPTER 5. CASE MANAGEMENT PRACTICES

### 10:91-5.1 Referral procedures

(a) Clients will be telephoned within 10 working days from the date of initial contact with the Commission. The supervisor will assign the applicant to a primary caseworker at this time.

(b) All emergency calls shall be responded to immediately.

(c) Referrals may be made by use of the toll-free 800 number available to callers throughout the State (see N.J.A.C. 10:91-4.1(a) 1).

### 10:91-5.2 Intake procedures

(a) The purposes of the intake interview shall be to gain an initial assessment of the applicant's total needs, to familiarize the applicant with Commission services and ways of helping, to respond to the applicant's most immediate or emergency needs, and to determine whether eligibility should be pursued, and, if so, to initiate together with the applicant, the development of a comprehensive service plan.

(b) The applicant survey is a device for gathering significant background information about the applicant during the initial interview. The survey is used by the Commission in identifying the needs of the applicant, making an overall assessment of the situation and developing a service plan. The survey is completed during the intake interview by the caseworker. After completion, the caseworker and the applicant, or his or her parent or guardian, shall sign the survey. The completed survey becomes a part of the applicant case record.

### 10:91-5.3 Case assignment and transfers

(a) Case assignments and transfers shall be made by a service supervisor or, if necessary, by the office manager.

(b) Case assignments shall be made to the primary caseworker whose area of expertise would involve 50 percent or more of the

services to be provided to a client. The primary caseworker shall function as the Commission's main representative to an individual client.

(c) When requested by the primary caseworker, an ancillary caseworker with specialization in an area other than that of the primary caseworker, shall be assigned to provide Commission services.

### 10:91-5.4 Service plan development

(a) The client and primary caseworker shall discuss and agree to an organized plan of services which addresses the client's needs. This service plan is developed for all clients once a client, parent or guardian has signed an applicant survey form or sent a letter requesting services and is called the Individual Client Service Plan (ISP). Vocational rehabilitation (VR) clients have an additional plan called the Individualized Written Rehabilitation Plan (WRP) which is developed once eligibility for VR services has been determined (see N.J.A.C. 10:91-2.3 and 2.7). The primary caseworker is responsible for completing all service plan documents. Both the client and caseworker shall sign the ISP and IWRP.

(b) The ISP shall be completed at a face-to-face meeting with the client as soon as possible after the client, parent or guardian has signed the applicant survey. The ISP indicates:

1. The type of exams needed to determine the client's eligibility for services;

2. The type of services to be provided;

3. Time frames for service provision;

4. The type of Commission specialist to whom the client will be referred; and

5. The client's comments, if any.

(c) The development and use of the IWRP is mandated by the Rehabilitation Act of 1973, as amended in 1986. (P.L. 99-506, Section 102(b) as amended). The IWRP contains:

1. The long range vocational goal which the services are expected to achieve;

2. The intermediate rehabilitation objectives related to the attainment of the goal;

3. The VR services to be provided with time frames for their provision;

4. The evaluation criteria and time schedule for determining whether the goals and objectives are being met;

5. A provision for an initial assessment of the need for post-employment services; and

6. Prior to case closure, a further reassessment.

(d) The IWRP is intended to insure that the client and primary caseworker shall have discussed and agreed to an organized plan of services addressing all of the client's vocationally relevant rehabilitation needs as documented in the certificate of eligibility.

(e) The IWRP shall further insure the establishment of planned time frames within which the services are to be provided.

(f) The IWRP shall also insure that the progress toward achievement of stated objectives will be regularly evaluated, and that the client, parent or guardian where appropriate shall have been fully informed of the rights and responsibilities that accompany acceptance into the VR program.

(g) The ISP and/or IWRP shall be reviewed with the client in a face-to-face meeting on an annual basis. A new ISP or IWRP shall be drawn up at the annual meeting between the primary caseworker and the client. The ISP or IWRP for the past year shall be annotated to reflect which objectives have or have not been accomplished. Revision of the ISP or IWRP may be necessary due to change in client's goals or objectives, change in a client's condition and/or situation, progress, achievement of objectives, newly identified problems or needs, or unobtainable objectives. For VR clients, an amendment to the IWRP shall be written. At case closure, the current ISP or IWRP shall be annotated to reflect which objectives were or were not achieved.

### 10:91-5.5 Purchase of services; emergency and immediate need situations

(a) Payment for purchase of services for clients may be made by the Commission when requested, approved and allocated from the

Commission funds. Primary and ancillary caseworkers may initiate requests for payment.

(b) Approved purchase of services through a rapid payments system shall be made by the Commission on behalf of a client to respond to an emergency or to purchase those client related services or commodities which cannot be purchased through normal procedures because of the presence of an immediate need.

(c) In emergency situations, an approved rapid payment shall be made within 48 hours of the original request.

(d) In immediate need situations, the rapid payment shall be made within two weeks of the initial request.

(e) Only the following service categories shall be permitted rapid payments:

1. Transportation services;
2. Maintenance services;
3. Prosthetics and aids;
4. Training materials or equipment; and
5. Placement tools or equipment.

(f) Client financial participation toward the expense of Commission services to be utilized shall be based on the level of responsibility set forth in detail in the financial need standard and survey (see N.J.A.C. 10:91-3.1).

(g) Authorized time limits shall be in writing and an authorization shall not exceed three months, unless written approval is obtained from the Chief of Field Operations.

**10:91-5.6 Referral to provider agencies**

(a) The function of the Commission's program development and contracting unit shall be to develop community based programs with provider agencies to meet the special needs of Commission clients and develop grants to obtain additional funds for specialized program development. The program development and contracting unit shall administer the purchase of service contracts on a Statewide and regional basis.

(b) Clients shall be referred to provider agencies for the purpose of achieving specific objectives or goals that the primary caseworker and the client have agreed are best achieved through the assistance of a provider agency. In making the referral, the primary caseworker shall indicate those services the provider agency is to provide. The client's ISP and IWRP shall contain a statement which specifies the fact that a particular provider agency will provide certain services so that the client might accomplish a specific objective or goal. Provided the client has signed a release to do so, information concerning a client's disabilities shall be provided the provider agency, as needed.

(c) On at least a quarterly basis the caseworker shall annotate the client's case record to reflect the outcome of the referral to the provider agency and/or the current status of the client's relationship with the provider agency. Additionally, the caseworker shall report in the client's case record any significant facts relative to the provider agency's service delivery to the client.

(d) All provider agencies shall submit a monthly report to the Commission, the contents of which shall be specified by contract.

**10:91-5.7 Release of information and access to records**

(a) No client information may be released unless Commission clients or their parents or guardians have consented in writing to such release or by order of a court of competent jurisdiction. This prohibition applies to release of the following:

1. Records from the Commission to outside agencies or practitioners;
2. Records from the Commission for other legitimate purposes; and/or
3. Records from outside agencies or practitioners to the Commission.

(b) A client and/or parent or guardian may authorize the release of confidential information and medical records to or from the Commission by signing a consent to release information form. This form shall specify the sending and receiving party, the purpose for which the release is required, and the date of the release.

(c) Personal information may be released to an organization, agency, or individual engaged in audit, evaluation, or research only for purposes directly connected with the administration of a vocational

rehabilitation program, or for purposes which would significantly improve the quality of life for clients and only if the organization, agency, or individual assures that:

1. The information will be used only for the purposes for which it is being provided;
2. The information will be released only to persons officially connected with the audit, evaluation or research;
3. The information will not be released to the involved individual;
4. The information will be managed in a manner to safeguard confidentiality; and
5. The final product will not reveal any personal identifying information without the informed written consent of the involved individual, or his or her representative.

(d) A Commission client may inspect and/or copy his or her own records. A client shall have access to all records relating to his or her eligibility for or receipt of assistance.

(e) To request access to records, a client or the client's parent, guardian or attorney shall submit a written request for permission to the regional or Statewide manager of the Commission. An attorney making the request shall also submit a written stipulation that he or she represents the Commission client and a release form, signed by the client, authorizing the disclosure of records to the attorney.

(f) Access to client information shall be denied when the prescribed procedures are not followed. The client shall be notified of the denial verbally and in writing by the regional or Statewide manager. The written notification shall set forth the reasons for the denial. A copy of the denial shall be placed in the client's case record.

(g) The regional or Statewide manager for the Commission shall forward a request for client access to his or her case records to the supervisor responsible for the client's case records. The supervisor shall contact the client, the client's parent or guardian or the client's attorney to schedule the date and time for review of the client's case records. Reader services shall be provided by the supervisor if the client requires them in order to review his or her case record. Clients or their representatives shall be charged the following fees, pursuant to N.J.S.A. 47:1A-1 et seq., for photocopying materials from the client's case records:

|                  |                 |
|------------------|-----------------|
| 1-10 pages       | \$ .50 per page |
| 11-20 pages      | \$ .25 per page |
| 21 pages or more | \$ .10 per page |

**10:91-5.8 Time limitation standards**

(a) All education and allied services applicants who have not had an eye examination within the year prior to the date of the application survey will need to schedule and undertake to have an eye examination within 45 calendar days of the date of the applicant survey.

(b) The following time limitation standards may be exceeded provided the caseworker justifies in writing the need for an extension of the times specified:

1. Within 30 calendar days from the date of referral, an individual shall be placed in applicant status or his or her case shall be closed (see N.J.A.C. 10:91-2.8 and 2.9);

2. Within 60 calendar days of a client being placed in applicant status for education and allied services, the client shall have eligibility determined, or have an individual service plan in effect, or the client's case shall be closed (see N.J.A.C. 10:91-2.8);

3. Within 120 calendar days of a client being placed in applicant status for vocational rehabilitation services, the client is placed in extended evaluation status, or VR eligibility shall be determined, or the client's case shall be closed (see N.J.A.C. 10:91-2.9);

4. VR clients in service plan development shall become involved in a diagnostic program within 90 calendar days of agreement to a service plan between client and primary caseworker. Within 30 calendar days of the completion of the diagnostic program, the Individualized Written Rehabilitation Plan (IWRP) shall be written and signed by the client, parent or guardian.

5. The VR services contained in the IWRP shall be implemented within 90 calendar days of the client's approval of this plan or the case shall be closed if implementation is impracticable (see N.J.A.C. 10:91-2.9); and

6. If a VR client is to receive homemaker training, the training shall commence within 90 calendar days of client's written approval

of this vocational plan and shall be completed within nine months of the start of training.

#### 10:91-5.9 Communicable diseases of Commission clients

(a) Upon learning of a client's communicable disease, a supervisor shall arrange for alternative services to a client where appropriate:

1. The supervisor shall develop a plan for an alternative service arrangement for the client during the pendency of the illness; and
2. The caseworker shall notify the client or his or her guardian in writing of established alternative service arrangements and the reasons for such action. The caseworker shall be responsible for the implementation of the alternative service plan.

(b) The Commission shall in all respects comply with statutory and regulatory requirements concerning reporting of communicable diseases (see N.J.A.C. 8:57-1).

#### 10:91-5.10 Reporting institutional abuse of elderly persons

Reporting of institutional abuse of elderly persons shall be undertaken pursuant to N.J.S.A. 52:27G-1 et seq. and N.J.A.C. 5:100.

#### 10:91-5.11 Reporting suspected child abuse or neglect

Reporting of suspected child abuse or neglect shall be undertaken pursuant to N.J.S.A. 9:60-8.8 et seq. and N.J.A.C. 10:129.

#### 10:91-5.12 Critical incidents involving clients

(a) A critical incident means the occurrence of serious accidental injuries to clients or suspected offenses involving injury to clients or their property which shall require the writing of an incident report. Incidents which need not be reported shall be those requiring only minor first aid treatment and which do not involve professional medical treatment, loss of consciousness or restriction of activity or motion.

(b) Incidents shall be verbally reported immediately to the Commission's Chief of Field Operations and Supervisor of Quality Assurance. This initial verbal notification shall be the responsibility of the Commission staff person who first learns of the occurrence of a critical incident, or his or her supervisor or manager and shall include:

1. The names and relationships of the persons involved;
2. The time, date and location of the incident;
3. A description of what occurred; and
4. The steps taken or to be taken to deal with the situation.

(c) Within 24 hours of this initial verbal notification, a written report shall be forwarded to the Chief of Field Operations and Supervisor of Quality Assurance containing the information listed in (b) above, and any other information related to the situation.

(d) Upon receipt of the initial verbal notification, the Commission's Executive and Deputy Directors shall be informed of the incident. All serious incidents shall be reported immediately by the Commission to the Commissioner of the Department of Human Services and its Office of Public Information.

(e) Within seven working days, the Supervisor of Quality Assurance shall initiate a follow-up investigation of the incident:

1. To determine any additional information not initially reported; and
2. To recommend any action or procedures to be taken to prevent a recurrence.

(f) The Commission's Executive Director or their designee shall supervise all follow-up activities, including presentation of recommendations, possible initiation of review by the Department of Human Services' Clinical Review Board, and implementation of all necessary actions.

(g) Based on the follow-up investigation report, the Commission's Chief of Field Operations shall oversee implementation of short- and long-term corrective actions.

### SUBCHAPTER 6. CLIENT APPEAL RIGHTS

#### 10:91-6.1 Recording of concerns by clients

Clients of the Commission for the Blind and Visually Impaired or their agents may record their concerns or problems regarding the timeliness of delivery of services or the adequacy of service by contacting their caseworker's supervisor or, in their absence, the office manager. The client also has the option of recording their concerns

or problems with the Commission's Client Service Representative (see N.J.A.C. 10:91-1.10). Clients requesting an administrative appeal of their case may also do this through the Client Service Representative (see N.J.A.C. 10:91-6.2).

#### 10:91-6.2 Administrative appeals

(a) A client (claimant) or his or her parent or guardian shall have the right to request an administrative appeal after all informal means of dispute resolution have been unsuccessful. The claimant may obtain an Administrative Appeal Request form from the caseworker or by telephone from the Client Service Representative, 1-800-962-1233 (see N.J.A.C. 10:91-1.10). Upon request, a claimant will be provided assistance in completing the form which will be forwarded, with relevant attachments, to the Executive Director of the Commission for the Blind and Visually Impaired. The claimant shall note on the form which type of appeal investigation is requested:

1. An administrative appeal investigation of the papers in the client's case file (a review of the papers); or
2. An administrative appeal investigation proceeding at which all relevant parties appear in person (an in-person review).

(b) Upon receipt of a request for an administrative appeal, the Executive Director shall assign a supervisory employee to conduct the appeal investigation and arrange to forward to that employee the client's case record. Neither the appeal investigator assigned this task nor his or her immediate supervisor shall have had any direct part in the dispute under appeal. Additionally, if the administrative appeal has been initiated by a VR services client, the assigned investigator shall have VR experience and knowledge.

(c) The appeal investigator conducting the administrative appeal investigation shall complete it within 30 working days of the time the client's case record shall have been received by him or her. This time limitation applies to both types of administrative appeal investigation.

(d) When the claimant requests an appeal investigation of the papers, the appeal investigator shall conduct an interview with the claimant, and as needed, other involved individuals. Notes of these interviews shall be typed and retained with the investigation records.

(e) When the claimant has requested an in-person administrative appeal investigation, the appeal investigator shall communicate with him or her to schedule it at a mutually convenient day and time between 9:00 A.M. and 5:00 P.M., Monday through Friday. The appeal investigation will be conducted at a regional or central office of the Commission. The appeal investigator will function as chairperson and arrange for minutes to be taken, typed and retained with the investigation records. If the client is unable to arrange for his or her transportation in order to be present at the appeal investigation, the Commission will make arrangements to provide transportation.

(f) The claimant at an in-person administrative appeal investigation will be permitted:

1. To represent him or herself or to be represented by an attorney or another individual;
2. To present his or her reason(s) for the appeal;
3. To recount his or her understanding of the Commission's position about the circumstances resulting in the appeal;
4. To submit additional documents; however, such documents shall be provided to the appeal investigator at least two working days prior to the date of the appeal investigation; and
5. To meet together with the appeal investigator and Commission staff member(s) involved in the appeal and to question them.

(g) A claimant who wishes to represent himself or herself shall be 18 years of age or older.

(h) A claimant who wishes to be represented by counsel shall make those arrangements independent of the appeal investigator, except that the appeal investigator will inform the claimant that a list of private attorneys is available from the bar association of the county where the client is domiciled. The claimant shall assume full responsibility for any and all legal costs incurred. A client who cannot afford a private attorney will be referred to a local legal services office or to the Department of the Public Advocate. Commission claimants who are also vocational rehabilitation services clients shall be referred to the Client Assistance Project (CAP) of the Department of the

Public Advocate. Both the Department of the Public Advocate and the CAP may be reached by telephone at 1-800-792-8600 or 1-609-292-9742.

(i) For the purpose of this section and as needed, all correspondence with a client will be in a medium accessible to a client.

(j) Within 25 working days of completing an appeal investigation, the appeal investigator shall submit a written report of his or her findings and recommendations to the Executive Director.

(k) Within five working days of an appeal investigation report being submitted to the Executive Director, the appeal investigator shall forward a registered letter to the allied or education client involved in the appeal, or their parent or guardian advising that:

1. The investigation has been completed;
2. A report of the investigation has been submitted to the Commission's Executive Director; and

3. The Executive Director, upon reviewing the report of the investigation, will immediately inform by registered letter, the client, parent or guardian whether the matter will be disposed of pursuant to (n) or (o) below.

(l) Within five working days of an appeal investigation report being submitted to the Executive Director, the appeal investigator shall forward a registered letter to the vocational rehabilitation client who filed an administrative appeal or their parent or guardian advising that:

1. The investigation has been completed;
2. A report of the investigation containing a recommended decision has been submitted to the Commission's Executive Director;
3. The client, parent or guardian has the right to request an administrative hearing before an administrative law judge if they disagree with the recommended decision;

4. A request for an administrative hearing will be in writing by registered mail from the client, parent or guardian to the Executive Director within 10 days of the client, parent or guardian receiving the registered letter from the appeal investigator; and

5. The Executive Director will notify the client, parent or guardian by registered letter, at the end of the 10 day comment period, whether the matter will be disposed of pursuant to (n) or (o) below.

(m) Based on the report submitted to the Executive Director by the administrative appeal investigator, and within 20 working days of receipt of the report, the Executive Director shall determine if the appeal is a contested versus a non-contested case (see N.J.A.C. 10:91-1.12).

(n) If the Executive Director determines that the administrative appeal represents a contested case or a vocational rehabilitation client or their parent or guardian requests an administrative hearing, the matter is immediately forwarded to the Office of Administrative Law pursuant to the Administrative Procedures Act, N.J.S.A. 52:14B-1 et seq., N.J.S.A. 52:14F-1 et seq., and the Uniform Administrative Procedure Rules, N.J.A.C. 1:1. The Executive Director will advise the client, parent or guardian of this action by registered letter.

(o) If the Executive Director determines that the administrative appeal represents a non-contested case, then the Executive Director shall issue a final decision and forward this decision by registered letter to the client, parent or guardian. The letter shall also contain a statement that any further appeal of this decision shall be made to the Appellate Division of the Superior Court of New Jersey.

(p) Following an administrative hearing of a contested case by an administrative law judge (ALJ), the ALJ renders a recommended decision that may be adopted, modified or rejected by the Executive Director, who by law is empowered to make a final decision in such matter. However, if the Executive Director does not so act in 45 days and unless such time limit is otherwise extended, this recommended decision shall become a final decision in accordance with N.J.S.A. 52:14B-10. The Executive Director shall advise the client, parent or guardian of the final decision and the reason for the decision, by registered letter.

SUBCHAPTER 7. MEDICAL POLICIES AND FEE SCHEDULES

10:91-7.1 Fee schedule

(a) In order to expedite authorizations for medical services, the Commission will maintain a medical fee schedule. This schedule will establish uniform and maximum authorization amounts for medical services. These services fall into one of the following categories:

1. Examinations;
2. Specialized eye procedures;
3. X-Ray, clinical, and lab tests;
4. Spectacles;
5. Contact lenses, prosthetics; and
6. Hospital clinic speciality procedures.

(b) As described in (a)1, 2, 3, and 6 above, and prior to certifying an authorization/invoice for payment of these services, the vendor shall provide to the client's caseworker a written report which details the services rendered by the vendor, the vendor's findings and recommendations, if any, and/or a description of the impact or the potential impact the service(s) has or will have on the client.

(c) The maximum authorization amounts in the Commission's medical fee schedule shall be established by the Commission's Administrative Medical Consultant. Prior to establishing a maximum amount, the Administrative Medical Consultant will do the following:

1. Review the current rate of payment for the service as established within the Blue Cross/Blue Shield 750 Series;
2. Review the current rate of payment for the service as established by other public health programs, for example, Medicaid or Medicare; and
3. Consult with applicable providers to gain an understanding of what the prevailing rate established by providers is.

(d) All established authorization amounts will be reviewed at least once every two years to determine if any adjustments are to be made to reflect inflation or other factors. Additionally, specific amounts will be reviewed at any time pursuant to a request for review from a provider or a Commission staff person or a change in Commission policy and procedure which will impact the providers associated with a particular Commission service, for example, low vision services.

(e) Changes to established maximum authorization amounts will be reflected in a timely fashion on the Commission's medical fee schedule.

(f) The maximum authorization amount for a medical service or a combination of services not listed on the Commission's medical fee schedule will be established on a case-by-case basis by the Commission's Administrative Medical Consultant based on a written request from a caseworker.

(g) Exceptions to an established maximum authorization amount will be granted by the Commission's Administrative Medical Consultant based on a written request from caseworker.

(h) The Commission's medical fee schedule follows:

**General examinations:**

|  |          |
|--|----------|
| General vision exam to determine classification including evaluation to determine need for field test              | \$ 45.00 |
| Follow-up treatment examination up to four each  | 25.00    |
| Exam under anesthesia  | 135.00   |
| General medical includes \$50.00 for medical exam and report, \$5.00 for urinalysis and \$5.00 for hemoglobin test | 60.00    |
| In-hospital pre-operative medical examination or consultation  | 60.00    |
| In-hospital follow-up visits up to five each   | 30.00    |
| Out of hospital pre-operative medical examination or consultation  | 60.00    |
| Otological, including audiogram  | 75.00    |
| Audiogram only   | 25.00    |
| Hearing aid evaluation   | 45.00    |
| Tympanogram  | 15.00    |
| Dental examination with full mouth X-rays  | 45.00    |
| Neurological evaluation  | 65.00    |

**PROPOSALS**

Interested Persons see Inside Front Cover

**HUMAN SERVICES**

|  |            |
|--|------------|
| Physical therapy per session, as approved by administrative medical consultant   | 55.00      |
| Psychiatric, psychological or other psychotherapeutic evaluation, three sessions, each up to                                 | 75.00      |
| Individual therapy, one hour   | 60.00      |
| Speech therapy, per session  | 55.00      |
| <b>Vision related consultative specialty examinations:</b>   |            |
| Corneal examination  | 60.00      |
| Glaucoma examination and report  | 60.00      |
| Hereditary evaluation  | 60.00      |
| Low vision exam for clients whose most recent eye report is one year old or less   | 100.00     |
| Low vision exam for clients whose most recent eye report is over one year old  | 125.00     |
| Up to three low vision exam follow-up visits which occur within four months of the date of the initial low vision exam, each | 25.00      |
| Low vision exam follow-up visit to fit fresnel prisms  | 22.00      |
| Motility examination   | 60.00      |
| Neuro-ophthalmological examination   | 130.00     |
| Neuro-ophthalmological follow-up exam, up to three allowed   | 30.00 each |
| In-hospital consultations, first consultation with detailed report   | 130.00     |
| Each succeeding day  | 30.00      |
| Oculo-plastic examination  | 60.00      |
| Ocular trauma examination  | 60.00      |
| Orthoptic evaluation   | 40.00      |
| Orthoptic follow-up exam   | 25.00 each |
| Orthoptic therapy, each session  | 20.00      |
| Out of hospital pre-operative ophthalmic examination or consult  | 45.00      |
| Pediatric ophthalmological examination   | 60.00      |
| Pleoptic evaluation  | 40.00      |
| Pleoptic therapy, each session   | 20.00      |
| Retinal examination  | 60.00      |
| Uveitis, tumor evaluation  | 60.00      |
| Uveitis evaluation follow-up   | 25.00      |
| <b>Specialized eye procedures:</b>   |            |
| <b>Eyelids:</b>  |            |
| Excision of cyst   | 55.00      |
| Chalazion (multiple \$150.00)  | 80.00      |
| Lesion (tumor)   | 135.00     |
| Plastic repair of lid laceration:  |            |
| Without graft  | 185.00     |
| With Graft   | 370.00     |
| Surgical correction of entropion or ectropion  | 345.00     |
| Ptosis surgical repair   | I.C. †     |
| Extensive plastic repair of lids and orbits  | I.C. †     |
| Incision and drainage of abscess   | 55.00      |
| Canthotomy   | 160.00     |
| Excision of xanthoma:  |            |
| Unilateral   | 160.00     |
| Bilateral  | 320.00     |
| Tarsorrhaphy   | 160.00     |
| Canthorrhaphy  | 160.00     |
| Punctual occlusion, other eye  | 160.00     |
| <b>Conjunctiva:</b>  |            |
| Incision and removal of foreign body:  |            |
| Surface  | 25.00      |
| Imbedded   | 30.00      |
| Excision—lesion of conjunctiva:  |            |
| Biopsy   | 35.00      |
| Excision of cyst or nevus  | 80.00      |
| Excision of pterygium  | 180.00     |

|   |          |
|---|----------|
| <b>Repair:</b>  |          |
| Conjunctivoplasty with free graft:  |          |
| Conjunctival graft  | 375.00   |
| Buccal mucosa membrane graft  | 425.00   |
| Suture laceration   | 50.00    |
| <b>Glaucoma procedures:</b>   |          |
| Goniotomy   | 280.00   |
| Peripheral iridectomy, laser or surgical  | 330.00   |
| Filter operation of any kind  | 400.00   |
| Iridotomy by stab incision for iris bombe   | 200.00   |
| Cyclo diathermy   | 230.00   |
| Cyclo dialysis  | 370.00   |
| Cyclo cyro therapy  | 240.00   |
| Argon laser or surgical trabeculectomy  | 400.00   |
| <b>Cornea:</b>  |          |
| <b>Keratotomy:</b>  |          |
| Removal of foreign body from surface  | 25.00    |
| Embedded in Cornea  | 35.00    |
| Keratotomy  | 240.00   |
| Keratoplasty (corneal transplant)   | 710.00   |
| Radial keratotomy (as approved by Administrative Medical Consultant)                | 635.00   |
| Epikeratophakia   | 635.00   |
| Removal of foreign body anterior chamber  | 370.00   |
| Delimiting keratotomy   | 95.00    |
| Cauterization or cryotherapy of lesion of cornea                                    | 50.00    |
| <b>Crystalline lens:</b>  |          |
| Cataract extraction by phaco  | 615.00   |
| Cataract extraction with intraocular lens insertion                                 | 915.00   |
| Cost of intraocular lens  | 370.00†† |
| Secondary lens implant  | 615.00   |
| Discission of lens, surgical  | 215.00   |
| YAG laser posterior capsulotomy   | 475.00   |
| Removal of intraocular lens   | 615.00   |
| <b>Eyeball:</b>   |          |
| <b>Excision:</b>  |          |
| Enucleation or evisceration   | 330.00   |
| With non movable implant  | 330.00   |
| With movable implant  | 375.00   |
| <b>Suture for wound or injury:</b>  |          |
| Non-perforating   | 140.00   |
| Perforating   | 470.00   |
| <b>Retina and vitreous:</b>   |          |
| Scleral buckling  | 845.00   |
| Sealing of retinal tear by argon laser coagulation                                  | 630.00   |
| Focal/Argon or krypton photo-coagulation for Rx of diabetic retinopathy unilateral: |          |
| Unilateral, initial treatment   | 290.00   |
| Up to three additional treatments (each)  | 190.00   |
| Pan retinal photo-coagulation for vein occlusion, initial treatment                 | 290.00   |
| One additional treatment  | 190.00   |
| Pan retinal photo-coagulation for diabetic retinopathy initial treatment            | 290.00   |
| Up to two additional treatments (each)  | 190.00   |
| Vitreotomy pars plana approach with or without lensectomy                           | 1,035.00 |
| Cryoablation of retina (blind eye)  | 240.00   |
| Gas fluid exchange  | 250.00   |
| Endophotocoagulation  | 250.00   |
| <b>Orbit:</b>   |          |
| <b>Plastic repair of orbit:</b>   |          |
| Fracture of floor   | 655.00   |
| Orbitotomy  | 375.00   |
| Removal of intra-orbital foreign body   | 425.00   |
| Orbitotomy (kroenlein) as in exophthalmos   | 610.00   |

**HUMAN SERVICES**

**PROPOSALS**

**Ocular Muscles:**

|   |        |
|---|--------|
| Strabismus Surgery:                     |        |
| One Muscle                              | 425.00 |
| Two Muscles, one or both eyes           | 470.00 |
| Three or more muscles, one or both eyes | 525.00 |

**Lacrimal procedures:**

|   |        |
|---|--------|
| Dacryocystorhinostomy   | 425.00 |
| Dacryocystectomy  | 375.00 |
| Incision and drainage of lacrimal sac or lacrimal gland abscess | 80.00  |
| Plastic repair of torn canaliculi                               | 265.00 |
| Probing of naso-lacrimal duct                                   | 30.00  |
| Subsequent (Max 4)  | 20.00  |

**X-ray:**

|   |        |
|---|--------|
| Skull—less than four views with or without stereo | 25.00  |
| Skull—complete, four views                        | 45.00  |
| Chest—single view                                 | 45.00  |
| Chest two views or stereo                         | 30.00  |
| Interpretation of chest—two views or stereo       | 15.00  |
| Chest—three views                                 | 40.00  |
| Chest—four views                                  | 45.00  |
| GI series—upper gastrointestinal tract            | 95.00  |
| CAT computerized tomography                       | 200.00 |
| Interpretation of CAT Scan                        | 45.00  |

**Special clinical tests:**

|  |       |
|--|-------|
| ECG, EKG, Electrocardiogram                                      | 25.00 |
| ECG, EKG interpretation  | 15.00 |
| ERG electro retinogram   | 55.00 |
| VER electro encephalogram  | 55.00 |
| Cardiovascular stress test                                       | 85.00 |
| Electroencephalogram   | 55.00 |
| Microscopic pathological evaluation of cataract after extraction | 5.00  |

**LABORATORY TESTS:**

|  |        |
|--|--------|
| Bun, Urea  | 7.00   |
| CBC (complete blood count)   | 7.00   |
| Creatinine   | 7.00   |
| Blood sugar  | 7.00   |
| Hemoglobin   | 6.00   |
| Serology   | 7.00   |
| Urine  | 6.00   |
| SMA 12   | 60.00  |
| Prothrombin (bleeding time)  | 6.00   |
| PTT (partial thromboplastin time)  | 7.00   |
| Pre-operative pre-admission testing, including chest x-ray, EKG, SMA 12 and urinalysis | 130.00 |

**Price list for spectacles:**

|  |        |
|--|--------|
| Spectacles complete with frames prescribed as a result of a general vision examination, no dispensing fee: |        |
| Single vision—distance or reading, spherical, hyperopia (+) or myopia (-)                                  | 60.00  |
| Single vision—distance or reading, spherocylindrical, astigmatism in addition to hyperopia or myopia       | 70.00  |
| Spherical bifocals, corrects both distance and reading   | 80.00  |
| If bifocal "add" greater than + 3.00   | 95.00  |
| Sphero-cylindrical bifocals (same as spherical bifocals, except also corrects for astigmatism)             | 85.00  |
| If bifocal "add" greater than + 3.00   | 100.00 |
| Single vision spherical cataract glass   | 95.00  |
| Single vision spherocylindrical cataract glass   | 100.00 |
| Bifocal—spherical cataract glass   | 140.00 |
| Bifocal—spherocylindrical cataract glass   | 150.00 |
| Welsh 4 Drop or OSI cataract glass   | 180.00 |
| Corning CPF UV lens  | 205.00 |

(Commission low vision consultants suggest that the examining doctor consider prescribing less expensive alternatives to these Corning lenses, that is, Younger PLS 530, 540 and 550)

**Spectacles prescribed as a result of a low vision evaluation:**

For the first or only pair made, the Commission will pay invoice costs for lenses and frames including a \$25.00 dispensing fee. A copy of the actual invoice shall be submitted for lenses and frames.

For each additional pair provided at the same time as the initial pair, the Commission will pay invoice costs and a \$12.50 dispensing fee. A copy of the actual invoice shall be submitted for lenses and frames.

**Spectacle mounted bioptics or clip-on low vision aids or custom made spectacles:**

The Commission will pay invoice costs for lenses and frames and a \$50.00 dispensing fee. A copy of the actual invoice shall be submitted for lenses and frames.

**Hard contact lenses:**

|                                       |              |
|---------------------------------------|--------------|
| Single lens                           | 135.00       |
| Two lens                              | 225.00       |
| Replacement lens                      | 45.00        |
| Hard pin hold contact lens (Aniridia) | 335.00       |
|                                       | up to 390.00 |

**Soft contact lenses (shall be initially approved by Administrative Medical Consultant):**

|   |        |
|---|--------|
| Single lens                               | 180.00 |
| Two lens                                  | 270.00 |
| Replacement lens (each)                   | 67.00  |
| Perma lens                                | 200.00 |
| Perma lens (pair)                         | 225.00 |
| Replacement perma lens (each)             | 73.00  |
| Gas permeable lens                        | 200.00 |
| Gas permeable lens (pair)                 | 300.00 |
| Replacement gas permeable lens (each)     | 85.00  |
| Bandage lens also called therapeutic lens | 200.00 |

**Ocular prosthesis:**

|   |        |
|---|--------|
| Custom fitted, hand painted, plastic ocular prosthesis                    | 335.00 |
| Custom fitted, hand painted, plastic scleral shell type ocular prosthesis | 390.00 |
| Orbital impression  | 110.00 |
| Custom fitted temporary ocular prosthesis                                 | 55.00  |
| Narcissus lens  | 390.00 |

**Non-spectacle low vision aids:**

The Commission will pay the price as listed in one of the following catalogs:

1. House of vision;
2. Lighthouse;
3. American Optical Company; or
4. Designs for Vision.

A copy of the page of the applicable catalog which stipulates the cost of the low vision aid shall be submitted by the low vision director. If an aid or device appears in a catalog distinct from those listed above, the Commission's payment shall be set by its low vision consultant.

**Hospital clinic and office specialty procedures:**

|   |        |
|---|--------|
| Beta radiation therapy following excision of pterygium (up to three treatments) | 50.00  |
| Bronson ultrasound B scan (intraocular foreign body)                            | 95.00  |
| Color perimetry   | 90.00  |
| Color fundus photos   | 45.00  |
| Corneal transplant tissue   | 235.00 |
| Dark adapt gross rod  | 130.00 |
| Dark adapt rod and cone plateau   | 160.00 |
| Electroculography   | 100.00 |
| Electro retinography  | 100.00 |
| Endothelial cell count  | 100.00 |
| Fluorescein angiogram with interpretation and written report                    | 100.00 |
| Fresnell prism monocular  | 20.00  |
| Fresnell prism binocular  | 30.00  |

|   |        |
|---|--------|
| resnell prism adaption                                      | 15.00  |
| ionioscopy  | 15.00  |
| oldman lens vitreous exam                                   | 15.00  |
| less screen exam  | 60.00  |
| achymetry   | 100.00 |
| erimetry (visual field)                                     | 25.00  |
| erimetry (threshold)  | 75.00  |
| erimetry (octopus)  | 100.00 |
| accadic velocity evaluation                                 | 105.00 |
| ervices provided by an ambulatory surgical center           | 700.00 |
| urgery set up (minor surgery)                               | 60.00  |
| onography   | 35.00  |
| ltrasoundography A (axial length measure monocular)         | 105.00 |
| ltrasoundography A (axial length measure binocular)         | 180.00 |
| ltrasoundography B (scan for vitreal and retinal pathology) | 100.00 |
| se for laser and room (only in hospital)                    | 200.00 |
| visual evoked response evaluation                           | 115.00 |
| Water bath ultrasound-monocular                             | 170.00 |

(a)

**DIVISION OF MEDICAL ASSISTANCE AND HEALTH SERVICES**

**Notice of Pre-Proposal**

**Pre-Admission Screening and Annual Residential Review for Medicaid Patients Seeking Admission to, or Residing in, Long Term Care Facilities**

Authorized By: Drew Altman, Commissioner, Department of Human Services.

Pre-Proposal Number: PPR 1989-6.

Take notice that, pursuant to Section 1919(e) of the Social Security Act, Medicaid patients who seek admission to long term care facilities (LTCFs) are required to undergo pre-admission screening, commencing January 1, 1989. This mandatory screening supersedes the Department's rules at N.J.A.C. 10:63-1.16(j)ii, which states that no prior authorization is needed for admission to an LTCF for an eligible Medicaid recipient from a general hospital, class "A" special hospital and a New Jersey Title XIX certified psychiatric hospital.

Pursuant to his authority under N.J.S.A. 30:4D-7, as required under the Federal Act, Drew Altman, Commissioner of the Department of Human Services, instituted pre-admission screening of Medicaid patients for admission to LTCFs on January 1, 1989. The following describes the pre-screening program now in operation:

Medicaid patients being admitted to long term care facilities (LTCFs) must be screened prior to admission. The patient may be living in the community, or may be hospitalized in an acute care general hospital. The patient could also be institutionalized in a private, state or county psychiatric hospital, or in an Intermediate Care Facility for the Mentally Retarded (ICF/MR). The purpose of the screening is to determine the suitability for nursing home care, and determine whether the patient requires active treatment for mental illness or mental retardation.

The initial patient evaluation will be conducted by a Regional Staff nurse from the Division of Medical Assistance and Health Services. Regional Staff Nurses have been evaluating patients for their need for care in an LTCF since the inception of the Medicaid program. However, the federal law cited above requires that the assessment (evaluation) be performed prior to the patient being admitted to the LTCF.

In addition to the regular nursing level of care assessment, the nurse must also determine if a referral for active treatment for mental illness needs to be made. The federal law specifies that an individual is considered mentally ill if there is a primary or secondary diagnosis of mental disorder.

Based on this diagnosis, and other appropriate criteria, the patient will be referred to the Division of Mental Health and Hospitals (DMH&H) for their review and evaluation by an independent psychiatrist. If there is a finding that active treatment is required, appropriate services will be provided or arranged for.

The same procedure would apply to mentally retarded individuals, who would be referred to the Division of Developmental Disabilities (DDD) for their portion of the active treatment review. If DDD's determination is that active treatment is appropriate, services will be provided or arranged for.

Persons adversely affected by determinations of active treatment for mental illness or mental retardation are entitled to a hearing.

Take further notice that the referenced Federal statute also requires the State to conduct assessments and active treatment reviews of residents residing in LTCFs. The deadline for such reviews is April 1, 1990.

Public comment on these requirements and the program set forth above is requested by the Department to assist it in formulating rules to govern the assessments, reviews and pre-admission screenings.

Interested persons may submit comments by October 5, 1989 to:

Henry W. Hardy, Esq.  
 Administrative Practice Officer  
 Division of Medical Assistance and Health Services  
 CN 712  
 Trenton, New Jersey 08625

Individual consideration by the Commission's administrative medical consultant.

To be allowed as a separate payment when outpatient surgery is performed in a freestanding outpatient facility or when surgery is performed on a "same day surgery" basis at a hospital. However, when surgery is performed on an in-patient basis, the cost of the lens is included in the DRG allowance.

10:91-7.2 Liability of Commission for missed medical appointments

(a) The Commission shall make no payment to a medical services provider for an education or allied services client who has given 24 hours notice of appointment cancellation.

(b) In the event that a Commission client fails to appear for a scheduled medical appointment or a Commission client fails to cancel a scheduled appointment prior to the date scheduled for the examination, the Commission shall be liable for one-half of the health provider's customary fee.

(c) Pursuant to Federal regulations, the Rehabilitation Services Administration has advised that the Commission shall not be liable for any fees associated with a missed medical appointment by a VR client.

10:91-7.3 Cataract surgery covered costs

The Commission shall cover the cost of outpatient facilities and services related to cataract surgery, for an eligible client, whether the surgery is conventional or employs a special procedure, such as an intraocular lens implant.

10:91-7.4 Payment to psychologists

(a) Psychologists who provide inservice training or who make formal presentations upon the request of the Commission shall be compensated at the rate of \$180.00 per diem.

(b) In the event that an education or allied services Commission client fails to appear for a scheduled test at the psychologist's office or fails to cancel an appointment to be tested prior to the date scheduled for the examination, a psychologist shall be reimbursed in the amount of \$45.00.

(c) In the event that an education or allied services Commission client fails to appear for a scheduled test at the Commission's offices or a location other than the psychologist's office, or fails to cancel an appointment prior to the date scheduled for the examination, a psychologist shall be reimbursed in the amount of \$90.00.

## COMMUNITY AFFAIRS

(a)

## DIVISION OF HOUSING AND DEVELOPMENT

Uniform Construction Code  
Barrier Free Subcode**Proposed Amendments: N.J.A.C. 5:23-7.2 through 7.6, 7.8, 7.9, 7.11, 7.12, 7.17, 7.18, 7.30, 7.37, 7.41, 7.55 through 7.57, 7.61, 7.67, 7.68, 7.71 through 7.73, 7.75, 7.76, 7.80 through 7.82, 7.87, 7.94 through 7.97**

Authorized By: Anthony M. Villane, Jr., D.D.S., Commissioner,  
Department of Community Affairs.

Authority: N.J.S.A. 52:27D-124.

Proposal Number: PRN 1989-466.

A **public hearing** on these proposed amendments will be held on October 2, 1989 at the offices of the Department of Community Affairs, Construction Code Element, 3131 Princeton Pike, Building 3, Lawrenceville, New Jersey, beginning at 9:30 A.M. All those interested in testifying are asked to notify the Administrative Practice Officer at the below address.

Submit written comments by November 6, 1989 to:  
Michael L. Ticktin, Esq.  
Administrative Practice Officer  
Department of Community Affairs  
CN 802  
Trenton, NJ 08625

The agency proposal follows:

**Summary**

Many of the following changes are being proposed to correct problems which have been noted with the Barrier Free Subcode adopted in November, 1986. These amendments are derived from comments received from licensed officials, architects and others using the subcode. Additionally proposed are changes to incorporate amendments made to enabling statute, N.J.S.A. 52:32-4 et seq. The following is a more detailed description of the proposed changes:

## N.J.A.C. 5:23-7.2 Scope and applicability

This section is amended to differentiate between large buildings (total gross enclosed floor area of 10,000 square feet or more) and small buildings (total gross enclosed floor area of less than 10,000 square feet) as required by the amendments made to the statute.

## N.J.A.C. 5:23-7.3(a) Exemptions

Exemption 1 has been changed from four or fewer dwelling units to three or fewer dwelling units to comply with the Federal Fair Housing Amendments Act of 1988. Exemption 5 has been deleted in accordance with the amended statute. Similarly, a new exemption 7 was added to reflect changes made to the enabling legislation. Exemption 7 for historical buildings has been deleted as including historical buildings under exemptions is misleading. Provisions for historical buildings have been added to N.J.A.C. 5:23-7.8, Alterations or changes of use. The language dealing with mechanical spaces has been amended for clarity.

## N.J.A.C. 5:23-7.4 Variations and exceptions

A sentence has been added to this section to indicate that accessible facilities suitable for use by adults must also be provided at facilities primarily serving children.

## N.J.A.C. 5:23-7.6 Definitions

Definitions of "area," "large building," and "small building" have been added to implement the changes to the statute.

## N.J.A.C. 5:23-7.8 Alterations or changes of use

The title has been changed to reflect properly the content of this section. Subsection (c) has been added to clarify that the provisions for alterations contained in the balance of the Uniform Construction Code apply in addition to the provisions contained in this section. Additionally, paragraph (c)1 and subsection (d) have been added to incorporate changes to the statute dealing with alterations and changes of use. Finally, subsection (e) has been added to describe the treatment of historic buildings, structures or sites under the subcode. This amendment is made to provide an objective method for determining the applicability of the provisions of the subchapter to historic buildings as required by the Appellate

Division decision in the case of *Community Health Law Project et al v New Jersey Department of Community Affairs*, Dkt. No. A-1496-867 (App. Div. 1988), *certif. den.* 113 N.J. 343 (1988).

## N.J.A.C. 5:23-7.9 Use Group I

Language has been added to make clear that accessible patient room are to be proportionately distributed among all patient care areas of all types and classes of patient rooms. Additionally, information on requirements for parking has been moved to N.J.A.C. 5:23-7.12 which contains all other requirements for parking. Also, a requirement for accessible inmate confinement areas has been added in accordance with the Appellate Division decision in this matter cited above.

## N.J.A.C. 5:23-7.11 Use Groups R-2 and R-3

To comply with the Appellate Division decision cited above, several clarifications have been made in this section. Specifically, a reference to N.J.A.C. 5:23-7.94 through 7.97 has been added as these sections contain the technical criteria for adaptable units. Also, the word "building" has been added to the section on multi-level units to clarify that building or projects with such units would fall into this category. Finally, the height restriction for applying the requirements of the subcode to entrance platforms serving only one unit has been removed.

## N.J.A.C. 5:23-7.12 Parking lots and parking garages

Requirements for parking in areas associated with buildings of Use Group I-2 have been moved to this section from N.J.A.C. 5:23-7.9 for uniformity.

## N.J.A.C. 5:23-7.13 Parking spaces

Figures 7.13b and 7.13c are replaced with identical, but graphically clearer, figures.

## N.J.A.C. 5:23-7.17(a)1 Accessible routes, walks and floors

This paragraph has been deleted as it has caused some confusion as to where accessible routes are to be provided.

## N.J.A.C. 5:23-7.18 Accessible routes: change in level

This section has been amended for consistency with the changes to the statute. Also, changes to the permitted uses for platform lifts made upon adoption of the subcode in November, 1986 have been proposed for comment in accordance with the Appellate Division decision.

## N.J.A.C. 5:23-7.19 Accessible routes: width

Figure 7.19c is replaced with a revised figure which corrects the "4'-0" or less" requirement to "less than 4'-0".

## N.J.A.C. 5:23-7.20 Accessible routes: protruding objects

Figure 7.20c is replaced with an identical, but graphically clearer figure.

## N.J.A.C. 5:23-7.30 Ramps: additional requirements

The diagram reference has been corrected to coincide with diagram changes.

## N.J.A.C. 5:23-7.31 Curb ramps: special requirements

Figure 7.31f is replaced with an identical, but graphically clearer, figure.

## N.J.A.C. 5:23-7.37(a)2 Accessible entrances

A cross reference to the section on additions has been added.

## N.J.A.C. 5:23-7.41 Doors and doorways: double leaf, revolving and turnstiles

The title has been changed to reflect accurately the section content.

## N.J.A.C. 5:23-7.42 Doors and doorways: clear width

Figures 7.42a through 7.42c are replaced with new figures which better illustrate the rule requirements.

## N.J.A.C. 5:23-7.55(a)1, 5 Accessible toilet and bathing facilities: water closets

The requirement that toilets be mounted with flush controls on the wide side of the access area has been deleted to allow an option for design professionals. Also, the language has been changed to indicate that toilet paper dispensers should be mounted at a height measured from the centerline of the dispenser. A new Figure 7.55d is proposed to reflect this revision.

## N.J.A.C. 5:23-7.56 Accessible toilet and bathing facilities: toilet stalls

The caption of Figure 7.56a is corrected, and Figure 7.56b is revised to reflect a three foot clear minimum only. The language has been changed to indicate that toilet paper dispensers should be mounted at a height measured from the centerline of the dispenser. Figure 7.56d is revised to conform.

## N.J.A.C. 5:23-7.57 Accessible toilet and bathing facilities: urinals

Standards have been added for a grab bar to be mounted next to urinals of standard height.

N.J.A.C. 5:23-7.58 Accessible toilet and bathing facilities: lavatories  
Figure 7.58a is replaced with an identical, but graphically clearer, figure.

N.J.A.C. 5:23-7.61 Accessible toilet and bathing facilities: bathtubs and showers  
A height has been added for the grab bar to be provided for tubs. The figure captions have been clarified, and a figure added to Figure 7.61a depicting "clear floor space with ledge seat (Frontal Approach)."

N.J.A.C. 5:23-7.65 Minimally accessible toilet and bathing facilities: clear spaces  
This rule is revised to require that fixtures be arranged as shown in Figure 7.65. The figure has been revised to include a note with this requirement.

N.J.A.C. 5:23-7.67 Minimally accessible toilet and bathing facilities: grab bars  
This section has been modified to differentiate between facilities in buildings of Use Group R-1, where the occupants change constantly, and facilities in buildings of Use Group R-2 where the occupants are more permanent.

N.J.A.C. 5:23-7.68 Elevators  
The requirements for the provision of elevators have been changed to conform with the amendments to the statute.

N.J.A.C. 5:23-7.71 Elevator door operation  
The reference at the end of this section has been deleted as it is repetitious and may become obsolete.

N.J.A.C. 5:23-7.72 Elevator car  
This section has been amended to include a requirement for handrails within elevator cars which was included in previous standards, but was inadvertently omitted from the subcode.

N.J.A.C. 5:23-7.73, 7.75 Elevators: car controls, lobby call buttons  
The requirement for both visual and audible signals indicating when a call is registered and answered has been deleted as this requirement exceeds the industry standard and would cause confusion.

N.J.A.C. 5:23-7.76 Elevators: hall lanterns  
This proposed change would limit the use of in-car lanterns mounted on car door jambs for hall lanterns to elevators with not more than two landings.

N.J.A.C. 5:23-7.80, 7.81 Platform lifts  
Several amendments are proposed to distinguish between vertical and inclined platform lifts.

N.J.A.C. 5:23-7.82 Drinking fountains and water coolers  
The requirements for installing drinking fountains have been corrected to indicate the proper height for mounting.

N.J.A.C. 5:23-7.87 Assembly areas  
Language has been added to clarify which type of assembly areas are meant to be included in this section.

N.J.A.C. 5:23-7.88 Mercantile fitting/dressing rooms  
An amendment has been made to this section to cross reference the requirements for accessible entrances.

N.J.A.C. 5:23-7.94 Residential adaptable units  
Reference to N.J.A.C. 5:23-7.95 through 7.97 has been added to clarify that all of these sections apply to adaptable dwelling units.

N.J.A.C. 5:23-7.95 Adaptable units: kitchens  
This section has been modified to delete the requirements for adjustable countertops and removable base cabinets, as well as the requirement pertaining to controls on appliances, as these requirements present certain problems for residents and the items in question can be altered for use by the disabled without a great deal of difficulty.

N.J.A.C. 5:23-7.96 Adaptable units: bathrooms  
The stipulation that the bathroom door cannot swing into the clear floor space has been deleted as the door could be reversed for a disabled resident.

N.J.A.C. 5:23-7.97 Adaptable units: consumer information  
A correction has been made changing the word "accessible" to "adaptable."

#### Social Impact

The major change effected by these proposed amendments is the implementation of the amendment to the statute. As amended, the statute no longer provides an exemption for office buildings of less than 10,000 square feet. Accordingly, disabled individuals will now be afforded an opportunity to obtain services, work and participate in other activities in newly-constructed small office buildings which were not previously

required to be accessible. Additionally, the corrections proposed should enhance the use of public buildings by the disabled.

#### Economic Impact

The economic impact of these proposed amendments depends upon the design of the individual building. Those constructing or purchasing new buildings or making renovations to existing buildings may incur some additional cost to comply with these proposed regulations. This cost will vary widely depending upon the building design.

The amendment of the rules to include office buildings of less than 10,000 square feet will have some economic impact on those constructing or purchasing new buildings or renovating existing buildings of this size. The dollar amount of the impact depends upon the design of the individual building.

#### Regulatory Flexibility Analysis

Because the rules now apply to office buildings of less than 10,000 square feet, there will be some economic impact on small businesses. As stated above, the nature of this impact depends upon the design of the individual building. However, the need to provide the access for the handicapped that is required by statute precludes the making of special exceptions for buildings owned by small businesses.

**Full text** of the proposal follows (additions indicated in boldface **thus**; deletions indicated in brackets [thus]):

AGENCY NOTE: At N.J.A.C. 5:23-7.18(a)3, language regarding platform lifts deleted upon adoption of the rule in November, 1986, is shown in brackets and italics to invite public comment upon the deletion.

#### 5:23-7.2 Scope and [Applicability] applicability

(a) The provisions of this subchapter shall apply to all buildings, building sites, and portions thereof, as delineated in (a)1 and 2 below, unless exempted by N.J.A.C. 5:23-7.3.

1. Large buildings, defined as those with a total gross enclosed floor area of 10,000 square feet or more, shall be required to have accessible entrances, facilities for the physically handicapped on all accessible floors, and elevators or other means of access for the physically handicapped between floors.

2. Small buildings, defined as those with a total gross enclosed floor area of less than 10,000 square feet, shall have accessible entrances servicing the first or ground floor areas and facilities for the physically handicapped on any other floors which are on an accessible route of travel.

(b)-(d) (No change.)

#### 5:23-7.3 Exemptions

(a) The following are exempt from the provisions of this subchapter:

1. Buildings or projects of Use Group R-2 or R-3 with [four]three or fewer dwelling units, having common entrances or separate entrances directly from the exterior, whether for rental or arranged for sale shall be exempt. A dwelling unit shall be deemed to be "arranged for sale" if it is located on a separate lot or is part of a condominium project for which a Master Deed has been filed and which has been approved for registration as a planned real estate development by the Department at the time that the building permit is issued.

i. (No change.)

2.-4. (No change.)

[5. Use Group B buildings used as offices with a total enclosed building area of all floors combined of 10,000 square feet or less shall be exempt.]

[6.]5. (No change in text.)

[7. Historic buildings and sites shall be exempt with regard to those provisions of this subchapter which would change the historic character of the building.]

[8. Mechanical and incidental storage spaces] 6. Floors or spaces containing only mechanical equipment shall be exempt.

7. Floors in large buildings which contain less than 3,000 square feet of total floor area and are at other than the entrance level shall be exempt.

i. Exception: Floors which contain less than 3,000 square feet of total floor area, but are served by an elevator or other means of access, shall not be exempt.

## 5:23-7.4 Variatons and exceptions

(a) (No change.)

(b) In buildings, facilities, or portions thereof which primarily serve children, variations and exceptions are not required for adjustments of dimensions to make them suitable for children. **However, in such buildings, accessible facilities for use by adults must be provided.**

(c)-(d) (No change.)

## 5:23-7.5 Construction Boards of Appeals

(a)-(b) (No change.)

(c) DCA shall sponsor and provide training to qualified handicapped persons and their advocates for inclusion on the list specified in [(c)] (b) above.

## 5:23-7.6 Definitions

The following words and terms, when used in this subchapter, shall have the following meanings unless the context clearly indicates otherwise:

...  
**"Area"** means the total gross floor area enclosed by exterior walls or fire walls. For the purposes of computing area or otherwise applying the provisions of this subchapter, the fire walls shall not be penetrated by openings of any kind whether protected or unprotected.

**"Large building"** means a building with a total gross enclosed floor area of 10,000 square feet or more.

...  
**"Small building"** means a building with a total gross enclosed floor area of less than 10,000 square feet.

## 5:23-7.8 Alterations or changes of use

(a)-(b) (No change.)

(c) **The degree to which alterations to existing buildings shall comply with the provisions of this subchapter shall be determined in accordance with N.J.A.C. 5:23-2.4.**

1. **Exception: The provisions of this subchapter shall not apply to renovations or modifications of a small building as defined in N.J.A.C. 5:23-7.6 if there is insufficient space between the building and its lot lines or between the building and the public way to allow for the installation of an entrance ramp which meets the criteria of this subchapter where one would be required.**

(d) **The provisions of this subchapter shall not apply to a change of use group of a small building as defined in N.J.A.C. 5:23-7.6.**

(e) **The provisions of this subchapter shall not be mandatory for the alteration of historic buildings, structures or sites provided that the following conditions are met:**

1. **The historic building, structure or site is designated, listed or registered by the State or Federal government authority as an historic building or site; and**

2. **A finding is made by the designating, listing or registering authority that compliance with the provision of the subchapter in question would alter the historic character of the building or site.**

## 5:23-7.9 Use Group I

(a) (No change.)

(b) Buildings or portions thereof of Use Group I-2 shall be made accessible as follows:

1. Hospitals licensed by the Department of Health shall be made accessible as follows:

i. Ten percent of patient bedrooms, rounded to the next higher whole number, shall be accessible.

(1)-(2) (No change.)

(3) Accessible patient bedrooms shall be proportionately distributed among all patient care areas **and through all types and classes of rooms within the areas (one-bedded, two-bedded, three-bedded and four-bedded rooms).**

2. (No change.)

3. Long Term Care Facilities (skilled nursing homes) licensed by the Department of Health shall be made accessible as follows:

i. Fifty percent of patient bedrooms, rounded to the next higher whole number, shall be accessible.

(1)-(2) (No change.)

(3) Accessible patient bedrooms shall be proportionately distributed among all patient care areas **and through all types and classes**

**of rooms within the areas (one-bedded, two-bedded, three-bedded and four-bedded rooms).**

4. Outpatient Facilities licensed by the Department of Health shall be made accessible as follows:

i. (No change.)

[ii. Ten percent of the parking spaces, but not less than two, shall be accessible.]

(c) Buildings or portions thereof of Use Group I-3 shall be made accessible as follows:

1. **At least one inmate confinement area or room per institution shall be accessible.**

2. **At least one toilet and bathing facility per institution provided for inmates shall be accessible.**

[1.] 3. All public or common areas and employee areas, including toilet or bathing facilities associated with these areas, shall be made accessible.

## 5:23-7.11 Use Group R-2 and R-3

(a) Buildings of Use Group R-2 or R-3, which are not exempted by N.J.A.C. 5:23-7.3, shall be made accessible to handicapped persons as follows:

1.-2. (No change.)

3. All units in elevator serviced buildings and all entry and/or grade level units in non-elevator serviced buildings shall be made adaptable in accordance with N.J.A.C. 5:23-7.94 through 7.97.

4. (No change.)

5. Each dwelling unit which has two or more levels of living space with an elevation difference of more than 24 inches and which does not have an internal elevator, is exempt from the requirements of N.J.A.C. 5:23-7.11(a)3. However, in each **building or project** containing such multi-level units, at least four percent of the total number of units[,] (rounded to the next whole number) shall be accessible or 100 percent of the units shall be adaptable.

6. (No change.)

## 5:23-7.12 Parking lots and parking garages

(a) Every parking lot or parking garage servicing an accessible entrance as described in this subchapter shall have at least the number of accessible parking spaces for the handicapped as set forth in Table 7.12.

1. Parking lots or parking garages servicing buildings of Use Group I-2 licensed by the Department of Health shall have at least the number of accessible parking spaces for the handicapped as set forth below:

i.-iii. (No change.)

iv. **In parking lots or parking garages servicing an outpatient facility, 10 percent of the parking spaces, but not less than two, shall be accessible.**

(b)-(c) (No change.)

## 5:23-7.13 Parking spaces

(a)-(b) (No change.)

(c) There shall be four acceptable configurations for accessible parking spaces as illustrated in Figures 7.13a through 7.13d.

1. (No change.)

2. Parking spaces each not less than eight feet wide with an adjacent access aisle at least five feet wide.

AGENCY NOTE: Current Figure 7.13b is proposed for deletion, but is not reproduced herein. The following is proposed new Figure 7.13b.

Figure 7.13b  
Parking Spaces

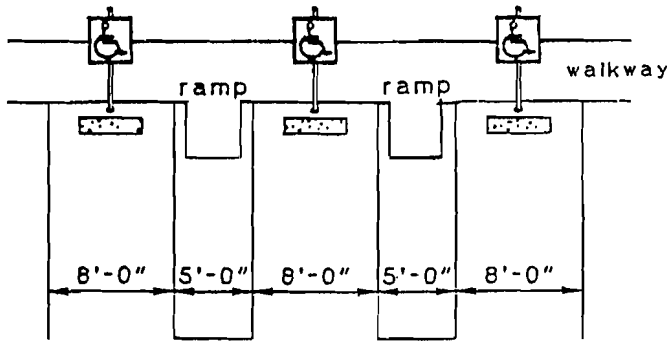

3. Curb side parking, provided that the curb has been indented at least four feet so that a handicapped person does not exit from a vehicle into a traffic lane.

AGENCY NOTE: Current Figure 7.13c is proposed for deletion, but is not reproduced herein. The following is proposed new Figure 7.13c.

Figure 7.13c  
Parking Spaces

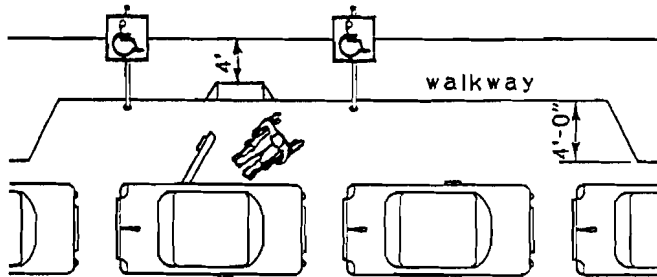

4. (No change.)  
(d) (No change.)

5:23-7.17 Accessible routes, walks and floors

(a) At least one accessible route shall comply with N.J.A.C. 5:23-7.18 through 5:23-7.23 and shall connect each accessible building entrance to the following:

[1. Accessible building entrances are not required to be connected to one another on the exterior of the building.]  
Renumber 2.-6. as 1.-5. (No change in text.)

5:23-7.18 Accessible routes: change in level

(a) All changes in level or grade on accessible routes, walks, or floors, shall comply with the following:

1.-2. (No change.)  
3. Changes in level of greater than three-quarter inch are to be connected by ramp, curb ramp, elevator, or platform lift meeting criteria of this subchapter. However, the maximum change in level within a building which may be bridged by a ramp shall be 60 inches. [Platform lifts may be used to bridge any level differential in modification and/or renovation work. In new construction, platform lifts shall be utilized only for access to special purpose areas and shall not be used on accessible routes between major floor areas or accessible entrances.]

4. (No change.)  
(b) The following are exceptions to the requirements of (a) above:  
1. (No change.)  
2. In Use Group[s] A-2 and in those buildings or areas of Use Group A-3 that are used as restaurants, raised or depressed areas not exceeding [32 inches in height] 3,000 square feet of total floor area shall be allowed provided [they encompass less than ten percent of the usable net area] that at least one-third of the usable net area is located

on an accessible route of travel and provided that identical facilities and services are available on accessible levels.

3. (No change.)

5:23-7.19 Accessible routes: width

(a) Accessible routes, walks and floors, shall provide clearances for moving wheelchairs as follows:

1. (No change.)

2. Maximum maneuvering clearances as shown in Figures 7.19b and 7.19c if the accessible route requires a turn around an obstruction.

Figure 7.19b (No change.)

AGENCY NOTE: Current Figure 7.19c is proposed for deletion, but is not reproduced herein. The following is proposed new Figure 7.19c.

Figure 7.19c  
Turn-Maneuvering Clearance

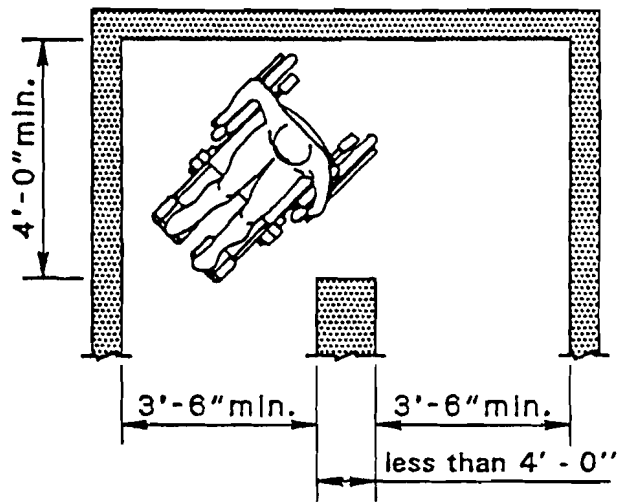

3. (No change.)

5:23-7.20 Accessible routes: protruding objects

(a) No protruding objects shall reduce the clear width of an accessible route or maneuvering space below the minimum required by N.J.A.C. 5:23-7.19. See Figure 7.20a.

Figure 7.20a (No change.)

1. (No change.)

2. Objects fixed to wall surfaces may project more than four inches if mounted with the lower extreme of their leading edge less than two feet three inches above the finished floor. These objects shall not project, however, into the minimum required clear width specified in N.J.A.C. 5:23-7.19. See Figure 7.20c.

AGENCY NOTE: Current Figure 7.20c is proposed for deletion, but is not reproduced herein. The following is proposed new Figure 7.20c.

Figure 7.20c  
Clear Width

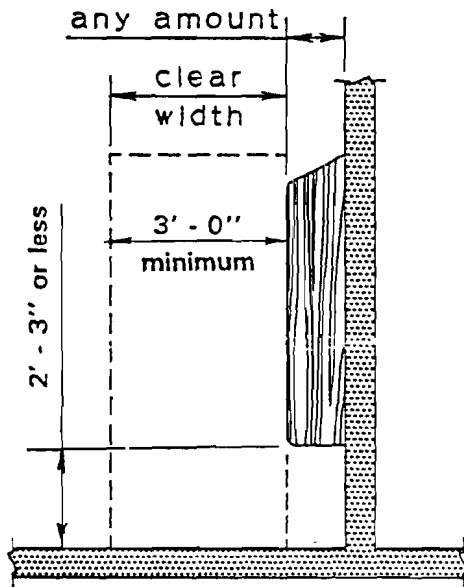
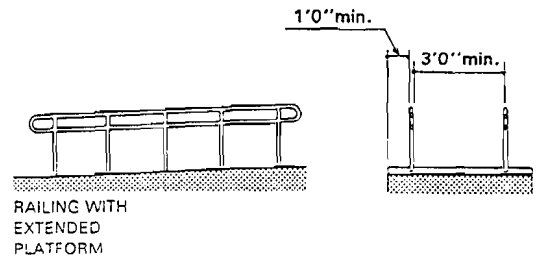

Figure 7.30d  
Ramp with Extended Platform



5:23-7.31 Curb ramps: special requirements

(a) In addition to the requirements of N.J.A.C. 5:23-7.24 through 5:23-7.30 above, curb ramps shall comply with the following requirements:

1.-3. (No change.)

4. Diagonal or corner-type ramps having flared sides shall have at least a two foot long segment of straight curb located on each side of the curb ramp and within the marked crossings. See Figure 7.31f.

AGENCY NOTE: Current Figure 7.31f is proposed for deletion, but is not reproduced herein. The following is proposed new Figure 7.31f.

3. (No change.)

5:23-7.30 Ramps: additional requirements

(a) In addition to the requirements of N.J.A.C. 5:23-7.24 through 7.29, all ramps shall meet the following requirements:

1.-2. (No change.)

3. Provide curbs, walls, vertical guards or projected edges at ramps and landings with drop-offs exceeding six inches. Minimum curb height shall be two inches. See Figures 7.30a through 7.30[c].d.

Figure 7.31f  
Crossing

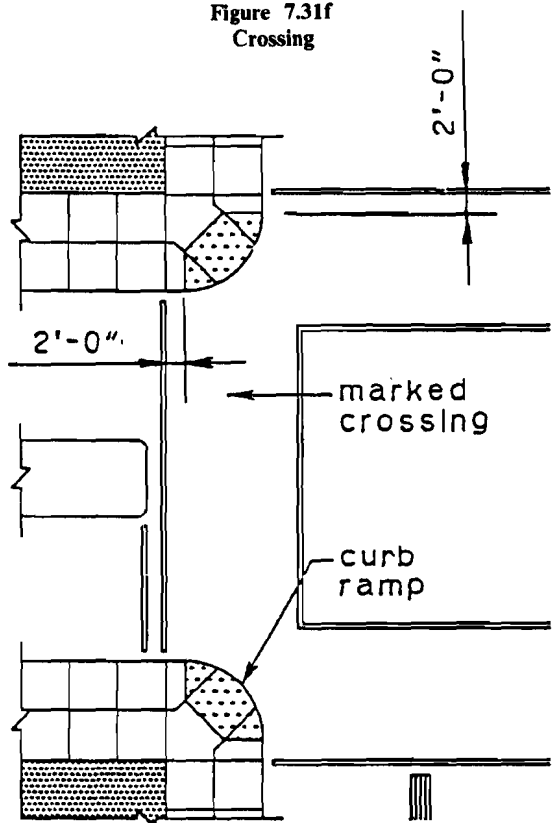

Figure 7.30a  
Ramp with Curb

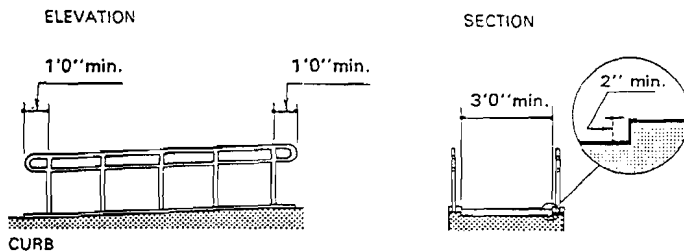

Figure 7.30b  
Ramp with Wall

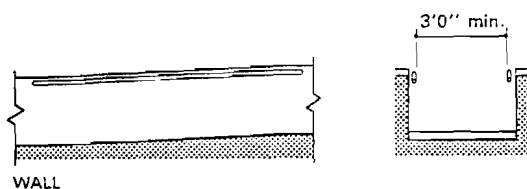
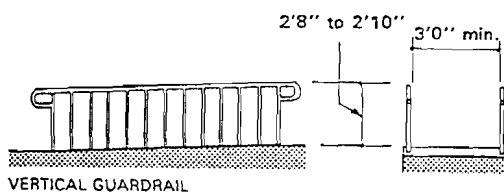

Figure 7.30c  
Ramp with Vertical Guards



5.-8. (No change.)

5:23-7.37 Accessible entrances

(a) The following entrances to a building or facility shall be constructed in a manner that makes them accessible either through adjusting the exterior grade level to coincide with the entrance or providing walkways, ramps, elevators or platform lifts which comply with this subchapter:

1.-2. (No change.)

3. For additions to existing buildings, the above requirements shall apply except if it can be shown that they have all been appropriately

met in the structure to which an addition is being made and there is an accessible route of travel from such entrances to the addition. Such entrances and accessible route must be available during all hours of operation of functions within the addition (see N.J.A.C. 5:23-7.7.);

5:23-7.41 Doors and doorways: [technical criteria] **double leaf, revolving and turnstiles**  
 (a)-(b) (No change.)

5:23-7.42 Doors and doorways; clear width  
 (a) Accessible doorways shall provide a clear opening of two feet eight inches as measured with the door open 90 degrees between the face of the door and the latch side stop. See Figure 7.42a, b, and c.

AGENCY NOTE: Current Figures 7.42a, b, and c are proposed for deletion, but are not reproduced herein. The following are proposed new Figures 7.42a, b, and c.

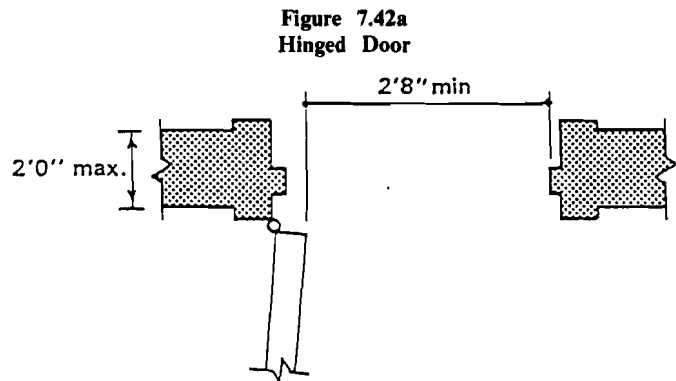

Figure 7.42a  
Hinged Door

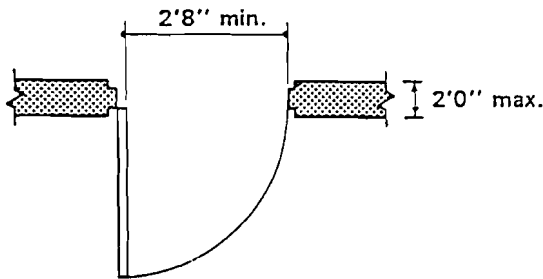

Figure 7.42b  
Sliding Door

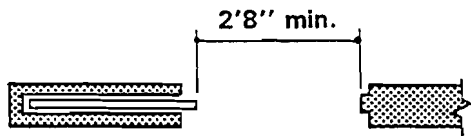

Figure 7.42c  
Folding Door

(b) (No change.)

5:23-7.55 Accessible toilet and bathing facilities: Water closets  
 (a) At least four percent (rounded off to the next higher whole number) but not less than one water closet in each toilet room shall:

- 1.-2. (No change.)
  - 3. Have automatic or hand operated flush controls. Controls shall be mounted [on the wide side of the access area] no higher than 44 inches above finished floor.
  - 4. Have grab bars mounted as shown in Figures 7.55c and d. Figure 7.55c (No change.)
- AGENCY NOTE: Current Figure 7.55d is proposed for deletion, but is not reproduced herein. The following is proposed new Figure 7.55d.

Figure 7.55d  
Side Wall

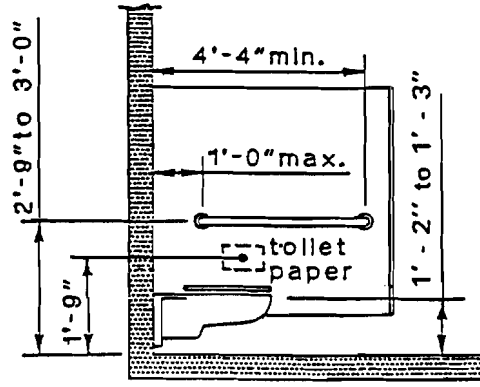

5. Have toilet paper dispensers mounted as shown in Figure 7.55d. Height measured from the [bottom] centerline of the dispenser to the finished floor shall be one foot nine inches. Dispensers shall not project beyond the front edge of the water closet. Dispensers that control delivery or do not permit continuous paper flow shall not be used.

5:23-7.56 Accessible toilet and bathing facilities: toilet stalls  
 (a) In toilet rooms containing toilet stalls, at least four percent, rounded off to next higher whole number, but not less than one stall, shall be made accessible.

- 1. (No change.)
- 2. Accessible toilet stalls shall be of the size and arrangement as shown in Figure 7.56a. Stall configuration may be reversed for left or right hand approach. In alteration work, where the provision of the standard stall (Figure 7.56a) is structurally impractical or plumbing fixture code requirements prevent combining existing stalls to provide necessary space, the alternate stall configuration of Figure 7.56b may be utilized.

Figure 7.56a  
Standard [Wall] Stall

(No change in Figure 7.56a.)  
 AGENCY NOTE: Figure 7.56b is proposed for deletion, but is not reproduced herein. The following is proposed new Figure 7.56b.

Figure 7.56b  
Alternate Stall

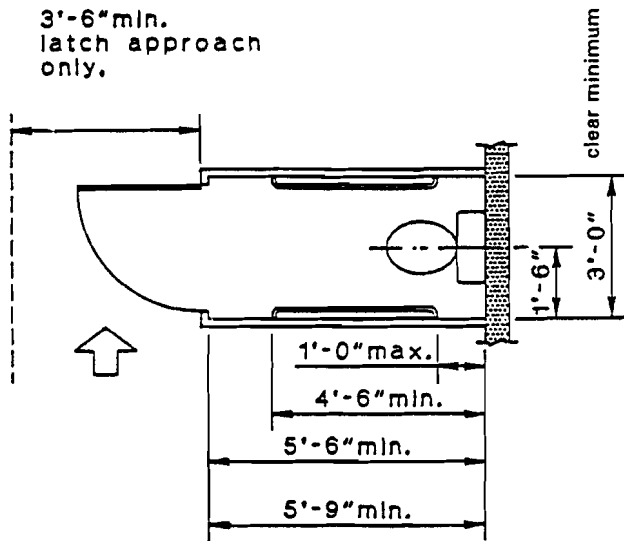

- 3.-5. (No change.)
- 6. Accessible toilet stalls shall have grab bars mounted as shown in Figures 7.56c and d.
- Figure 7.56c (No change.)
- AGENCY NOTE: Current Figure 7.56d is proposed for deletion, but is not reproduced herein. The following is proposed new Figure 7.56d.

Figure 7.56d  
Side Wall

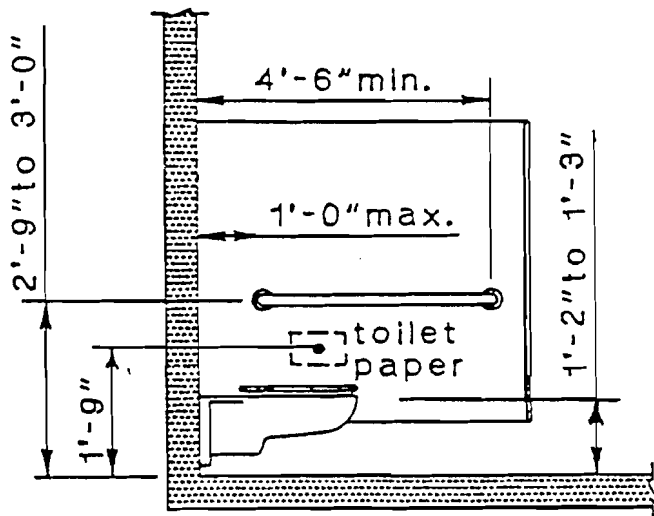

7. Accessible toilet stalls shall have toilet paper dispensers mounted as shown in Figure 7.56d. Height measured from the [bottom] centerline of the dispenser to the finished floor shall be one foot nine inches. Dispensers shall not project beyond the front edge of the water closet. Dispensers that control delivery or do not permit continuous flow shall not be used.

- 5:23-7.57 Accessible toilet and bathing facilities: urinals
- (a) (No change.)
- (b) A vertical grab bar shall be located next to at least one standard height urinal [at standard height]. The grab bar should be 24 inches in length, installed with its centerline 36 inches from the finished floor.

- 5:23-7.58 Accessible toilet and bathing facilities: lavatories
- (a) Four percent (rounded off to next higher whole number) in each toilet room or bathing facility, but not less than one, shall be accessible. Accessible lavatories shall meet the following requirements.
- 1. Lavatories with the rim or counter surface shall be mounted no higher than [2] two feet 11 inches above finished floor. Knee space between bottom of apron and finished floor shall be at least two feet six inches high, two feet six inches wide, and one foot seven inches deep. Toe space of at least nine inches high shall be provided. See Figure 7.58a.
- AGENCY NOTE: Current Figure 7.58a is proposed for deletion, but is not reproduced herein. The following is proposed new Figure 7.58a.

Figure 7.58a  
Lavatory

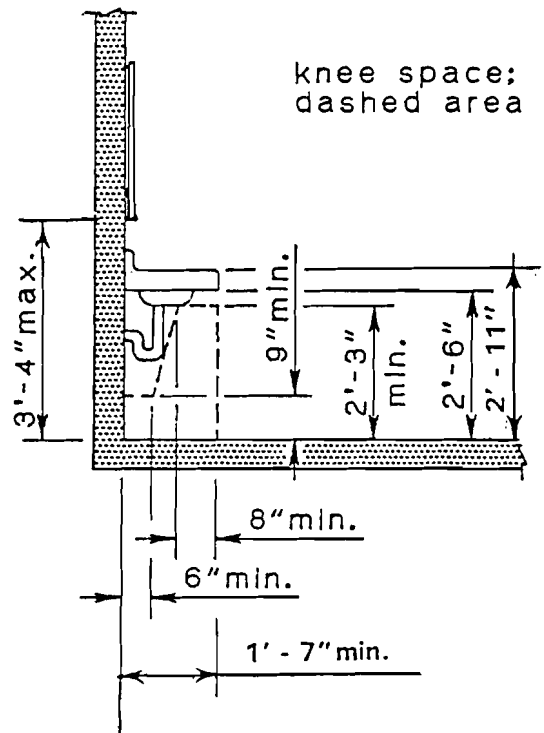

- 2.-5. (No change.)
- 5:23-7.61 Accessible toilet and bathing facilities: bathtubs and showers
- (a) At least one fixture of each type provided shall be made accessible in each toilet or bathing facility (where required). Accessible bathtubs or showers shall:
- 1.-2. (No change.)
- 3. Have grab bars mounted as shown in Figures 7.61a through 7.61e. Grab bars provided for tubs shall be mounted at a height of nine inches above the flood rim. See specifications for grab bars in N.J.A.C. 5:23-7.62.

Figure 7.61a  
Clear floor space with ledge seat  
(Lateral Approach)

(No change in current Figure 7.61a; proposed additional aspect of Figure 7.61a reproduced below.)

Clear floor space with ledge seat  
(Frontal Approach)

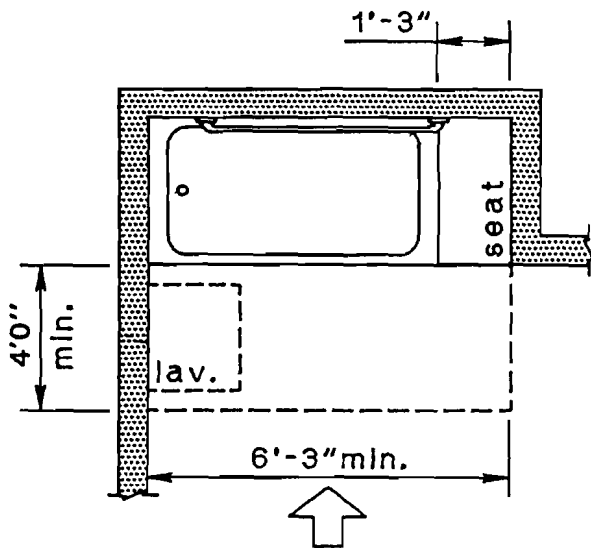

Figure 7.61b  
Clear floor space with in-tub seat  
Frontal Approach

(No change in Figure 7.61b)

Figure 7.61c  
Clear floor space with in-tub seat  
Lateral Approach

(No change in Figure 7.61c)

Figure 7.61d  
Clear floor space  
Transfer stall shower

(No change in Figure 7.61d.)

Figure 7.61e  
Clear floor space  
Roll-in stall shower

(No change in Figure 7.61e.)

4.-7. (No change.)

5:23-7.65 Minimally accessible toilet and bathing facilities: clear spaces

(a) Each toilet room and bathing facility shall have an unobstructed clear space that:

1. Is a minimum of 60 inches long and 32 inches wide, with the door opening onto the 32 inches side. See Figure 7.65. Fixtures must be arranged as shown in Figure 7.65.

AGENCY NOTE: Current Figure 7.65 is proposed for deletion, but is not reproduced herein. The following is proposed new Figure 7.65.

Figure 7.65  
Clear Space

Note: Fixtures must be arranged as shown.

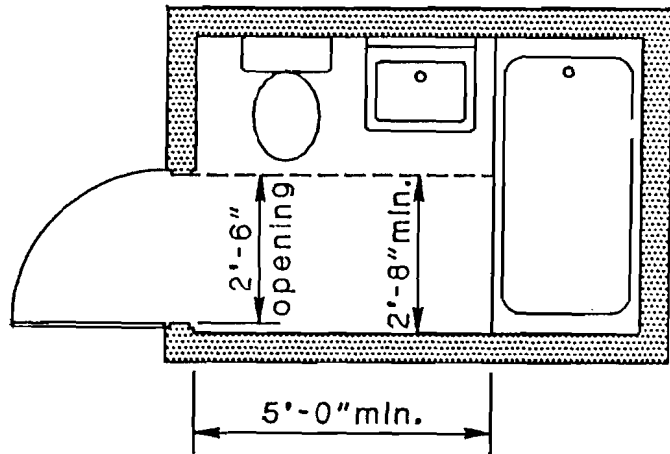

2. (No change.)

5:23-7.67 Minimally accessible toilet and bathing facilities: grab bars

[Each] In buildings of Use Group R-1, each toilet room and bathing facility required to be minimally accessible shall have grab bars meeting criteria of N.J.A.C. 5:23-7.62 mounted at the foot and back of tubs of the length and positioning shown in figures 7.67a and b. In buildings of Use Groups R-2 and R-3, each toilet room and bathing facility required to be minimally accessible shall have blocking for grab bars at the foot and back of tubs, positioned as indicated in Figures 7.67a and b.

Figures 7.67a and b. (No change.)

5:23-7.68 Elevators

(a) Every multi-storied building shall provide elevator(s) that are accessible to and usable by physically handicapped people with the following exceptions:

1. Small buildings as defined in N.J.A.C. 5:23-7.6;

2. In large buildings as defined in N.J.A.C. 5:23-7.6, floors which contain less than 3,000 square feet of total floor area or floors which contain only mechanical equipment;

[1. In Use Group B, buildings with less than 6,000 square feet of total gross area at other than the principal entrance level.]

[2.]3. In Use Groups B and F, mezzanines of less than [10,000] 3,000 square feet total gross area.

Renumber 3. as 4. (No change in text.)

(b)-(c) (No change.)

5:23-7.71 Elevator door operation

(a) Elevator doors shall be a minimum of three feet-wide and automatic door controls shall comply with the following requirements:

1.-2. (No change.)

3. Doors shall have a reopening device which will function to stop and reopen the car door and adjacent hoistway door in case the cardoor is obstructed when the door is closing. This reopening device shall also be capable of sensing an object or person in the path of a closing door without requiring contact for activation at a nominal height of five inches and two feet five inches above finished floor. Such devices shall remain effective for a period not less than 20 seconds. [For additional information, see ANSI A17.1 as referenced in Appendix A of the building subcode.]

5:23-7.72 Elevator car

(a)-(b) (No change.)

(c) Handrails shall be provided on all walls of cars except where doors occur. Rails shall be smooth and the inside surface at least one

**and one-half inches clear of the walls at a nominal height of 32 inches from the floor.**

5:23-7.73 Elevators: car controls

(a)-(b) (No change.)

[(c) Both a visual and audible signal indicating when each call is registered and answered shall be provided.]

Redesignate (d)-(e) as (c)-(d). (No change in text.)

[(f)] (e) All control buttons shall be designated by raised standard alphabet characters for letters, arabic characters for numerals, or standard symbols as shown in Figure 7.73b. [For additional information see ANSI A17.1 as referenced in Appendix A of building subcode and see also NEII suggested Minimum Elevator Requirements for the Handicapped.] Raised designations shall be placed to the immediate left of the button to which they apply. Permanently attached or applied plates are acceptable. The call button for the main entry floor shall be located in the left-most column designated with a raised star as shown in Figure 7.73b.

Figure 7.73b (No change.)

Redesignate (g) as (f). (No change in text.)

5:23-7.75 Elevators: lobby call buttons

(a) Lobby call buttons shall:

1.-2. (No change.)

3. Have [both] visual [and audible] signals indicating when a call is registered and answered;

4.-6. (No change.)

5:23-7.76 Elevators: hall lanterns

(a) Audible and visual signals shall be provided at each hoistway entrance to indicate car arrival and its travel direction.

1.-2. (No change.)

3. **For elevators with not more than two landings, [In]in-car lanterns mounted on car door jambs and that comply with N.J.A.C. 5:23-7.74 are acceptable.**

5:23-7.80 Platform lifts

(a) Platform lifts shall:

1. Accommodate an occupied wheelchair. [See Figure 7.80.] **For vertical lifts, the platform shall be at least 30 inches in width and 48 inches in length. For inclined lifts, the platform shall be at least 28 inches in width and 35 inches in length.**

AGENCY NOTE: Figure 7.80, not reproduced herein, is proposed for deletion.

2.-4. (No change.)

5:23-7.81 Technical criteria for platform lifts

(a)-(c) (No change.)

(d) [Guarding] **For vertical lifts, guarding around the lift shall be provided as follows:**

1.-2. (No change.)

(e) through (f) (No change.)

5:23-7.82 Drinking fountains and water coolers

(a) through (b) (No change.)

(c) Water spouts on accessible drinking fountains shall:

1. Be mounted [no higher than] three feet above the finished floor, measured to the water outlet of the spout;

3. (No change.)

(d) (No change.)

5:23-7.87 Assembly areas

(a) Assembly areas, **such as auditoriums and other similar assembly areas, which provide fixed seating for viewing a performance or event shall comply with this section.** Assembly areas shall provide the number of accessible viewing position as specified in Table 7.87.

1.-3. (No change.)

5:23-7.88 Mercantile-fitting/dressing rooms

In each department (for example, sportswear, swimsuits, lingerie, etc.) where fitting rooms are provided, at least one fitting/dressing room shall be made accessible and a size five feet by five feet (minimum) with [a clear opening of 43 inches minimum] **an entrance having a clear opening complying with N.J.A.C. 5:23-7.42 through 7.46.** [Hardware on fitting room doors shall comply with N.J.A.C. 5:23-7.46.]

5:23-7.94 Residential adaptable units

(a) (No change.)

(b) **Adaptable units shall comply with N.J.A.C. 5:23-7.95 through 7.97.**

5:23-7.95 Adaptable units: kitchens

(a) Kitchens in adaptable units shall be on an accessible route and shall meet the following criteria:

1.-2. (No change.)

[3. All controls for appliances, sinks and other equipment shall comply with N.J.A.C. 5:23-7.85 (Controls and operating mechanisms).]

[4.]3. At least one 30 inch section of counter shall provide a work surface that complies with the following requirements:

[i. The counter shall be adjustable or replaceable as a unit to provide alternative heights of 28 inches, 32 inches, and 36 inches measured from the floor to the top of the counter surface;]

[ii. Base cabinets, if provided, shall be removable under the full 30 inches minimum frontage of the counter.] i. The finished floor shall extend under the counter to the wall;

Renumber iii. as ii. (No change in text.)

[iv.] iii. A clear floor space 30 inches by 48 inches shall allow a forward approach to the counter. Nineteen inches maximum of clear floor space required may extend underneath the counter. The knee space shall have a minimum clear width of 30 inches and a minimum clear depth of 19 inches. **NOTE: The measurement of knee space assumes the removal of base cabinets;**

Renumber v. as iv. (No change in text.)

[5.]4. The sink and surrounding counter shall comply with the following requirements:

i. [The sink and surrounding counter shall be adjustable or replaceable as a unit to provide alternative heights of 28 inches, 32 inches, and 36 inches, measured from the floor to the top of the counter surface or sink rim.] The total width of sink and counter area shall be 30 inches minimum;

ii. (No change.)

iii. [Base cabinets, if provided, shall be removable under the full 30 inch minimum frontage of the sink and surrounding counter.] The finished flooring shall extend under the counter to the wall;

iv. (No change.)

v. A clear floor space 30 inches by 48 inches shall allow forward approach to the sink. Nineteen inches maximum of the clear floor space may extend underneath the sink. The knee space shall have a minimum clear width of 30 inches and a clear depth of 19 inches. **NOTE: The measurement of knee space assumes the removal of base cabinets;**

vi. (No change.)

5:23-7.96 Adaptable units: bathrooms

(a) Each bathroom required to be adaptable shall be on an accessible route and shall meet the requirements of this section.

[1. Doors shall not swing into the clear floor space required for any fixture.]

Renumber 2.-5. as 1.-4. (No change in text.)

5:23-7.97 Adaptable units: consumer information

(a) To ensure that the existence of adaptable features will be known to the owner or occupant of a dwelling, the following consumer information shall be provided in each [accessible] **adaptable** dwelling unit for rent or sale:

1.-5. (No change.)

(a)

**DIVISION OF HOUSING AND DEVELOPMENT****Uniform Construction Code  
Educational Facility Use Group****Proposed Amendment: N.J.A.C. 5:23-3.5**

Authorized By: Anthony M. Villane Jr., D.D.S., Commissioner,  
Department of Community Affairs.

Authority: N.J.S.A. 52:27D-123.

Proposal Number: PRN 1989-449.

Submit comments by October 5, 1989 to:

Michael L. Ticktin, Esq.  
Administrative Practice Officer  
Department of Community Affairs  
CN 802  
Trenton, New Jersey 08625

The agency proposal follows:

**Summary**

When the original text of the rules for the State Uniform Construction Code was written in 1977, it was based on references to the 1978 Edition of the BOCA Building Code. Under that edition of the code, educational facilities were categorized as "A-4," a type of assembly building, there being no category of buildings specific to those used for education.

Because educational facilities were found to differ from other types of "assembly uses" (movies, theatres, convention halls, night clubs, etc.), a new E Use Group for educational facilities was developed. It appears in the 1984 Edition of the BOCA Building Code and is in the current 1987 Edition (with 1988 and 1989 supplements).

The text of N.J.A.C. 5:23-3.5(b), adopted in 1977, purports to apply to educational buildings, but does not include a reference to the E Use Group. The code section was never amended when the E Use Group was created and thus the text is inconsistent with other provisions of the Code.

Code officials and representatives of the Department of Education have been confused by the code section's apparent intent but incomplete reference.

This amendment should prevent further confusion with regard to this matter.

**Social Impact**

There is no anticipated substantive social impact from this clerical amendment. It is intended to update an incomplete reference in the code which has caused confusion among enforcement officials.

**Economic Impact**

There is no anticipated economic impact from this clerical amendment. What is required by the code section is similarly required by N.J.A.C. 5:18-3.2, Article 1500 (F-1500.4), of the New Jersey Uniform Fire Code. It is assumed that most educational facilities are already complying with the substance of this requirement.

**Regulatory Flexibility Analysis**

This clerical amendment has no differential effect on large and small businesses, and in fact, does not present any new requirements for which there would be a cost for compliance.

**Full text of the proposal follows (additions indicated in boldface thus):**

5:23-3.5 Posting structures

(a) (No change.)

(b) Posted occupancy load: Every building and structure and part thereof designed for use as a place of public assembly or as an institutional building for harboring people for penal, correctional, educational, medical or other care or treatment (use groups A, E and I) shall be posted with an approved placard designating the maximum occupancy load.

(c)-(e) (No change.)

# RULE ADOPTIONS

## BANKING

### (a)

#### DIVISION OF BANKING

#### Notice of Administrative Correction Check Cashing Facilities Conduct of Business

#### N.J.A.C. 3:24-5.1

Take notice that the Department of Banking, Division of Banking, has discovered several spelling errors in the Spanish-language sign text required, pursuant to N.J.A.C. 3:24-5.1(a)1, to be posted in all check cashing facilities. This notice of administrative correction is published in accordance with N.J.A.C. 1:30-2.7(a)1.

Full text of the corrected rule follows (additions indicated in boldface thus; deletions indicated in brackets [thus]):

#### 3:24-5.1 Conduct of business

##### (a) Every licensee shall:

1. Post and at all times display in a conspicuous place on the premises the license and also the schedule of rates to be charged.

i. The Department of Banking shall provide signs to each licensed check casher which shall be posted in the licensed premises. The Department of Banking shall determine the number of signs which shall be posted and shall designate those areas in the check cashing facility where these signs shall be displayed. These signs shall be in both the English and Spanish languages. The contents of the signs shall be as follows, except that different language may be mandated by the Department as it deems necessary to accomplish the purpose of this chapter:

(No change in English-language sign text.)

**CASAS DE CAMBIO CON [LICENSIA] LICENCIA  
DEL ESTADO  
TARIFAS MAXIMAS CUAL DEBE SER COBRADAS  
CHEQUES DE NUEVA JERSEY  
1% DEL TOTAL DE SU CHEQUE**

Ejemplo:

|                         |                 |    |
|-------------------------|-----------------|----|
| Cheques de Nueva Jersey | \$300.00        |    |
| Tarifa maxima           | <u>\$ 3.00</u>  | 1% |
| Restante de su cheque   | <u>\$297.00</u> |    |

**CHEQUES [FUETA] FUERA DE NUEVA JERSEY  
1½% DEL TOTAL DE SU CHEQUE**

Ejemplo:

|                               |                 |     |
|-------------------------------|-----------------|-----|
| Cheques fuera de Nueva Jersey | \$300.00        |     |
| Tarifa maxima                 | <u>4.50</u>     | 1½% |
| Restante de su cheque         | <u>\$295.50</u> |     |

[Cuendo] Cuando cambie su cheque debe recibir un RECIBO el cual diga: el nombre de la casa de cambio, [numero] numero de cajera, [decuanto] de cuanto fue su cheque, la tarifa que usted pago, y cuanto recibio usted en efectivo.

Si usted tiene alguna queja o problema o si no recibio un recibo, llame gratis al 1-800-421-0069.

Departamento de Bancos  
CN 040  
Trenton, New Jersey 08625  
Casa de Cambio (\_\_\_\_\_)  
Numero de Referencia \_\_\_\_\_

ii.-iii. (No change.)

2.-8. (No change.)

(b) (No change.)

## EDUCATION

### (b)

#### STATE BOARD OF EDUCATION

#### Substance Abuse

#### Adopted Amendments: N.J.A.C. 6:29-9

Proposed: June 19, 1989 at 21 N.J.R. 1603(a).

Adopted: August 2, 1989 by Saul Cooperman, Commissioner, Department of Education; Secretary, State Board of Education.

Filed: August 14, 1989 as R.1989 d.480, with substantive and technical changes not requiring additional public notice and comment (N.J.A.C. 1:30-4.3).

Authority: N.J.S.A. 18A:1-1, 18A:4-10, 18A:4-15, 18A:40A-1, 18A:40A-2, 18A:40A-4, 18A:40A-10, 18A:40A-11, 18A:40A-12, 18A:40A-13, 18A:40A-14, 18A:40A-15 and 42 CFR 2.

Effective Date: September 5, 1989.

Expiration Date: March 25, 1990.

#### Summary of Public Comments and Agency Responses:

Two letters with comments were received; one individual spoke at the public testimony opportunity. A summary of their comments and agency responses follows:

COMMENT: One individual submitted the following comments:

1. Has N.J.A.C. 6:29-9.4 been omitted from the Code since it did not appear in the New Jersey Register?

2. The definition of treatment (N.J.A.C. 6:29-9.2) should remain as it is in the existing version.

3. N.J.A.C. 6:29-9.5(a)8, which states that refusal or failure by a parent to comply with the provisions of N.J.S.A. 18A:40A-12 shall be deemed a violation of compulsory attendance, should be eliminated.

RESPONSE: The response by the Department to these comments is the following:

1. No, N.J.A.C. 6:29-9.4 has not been omitted from the Code. That section had no changes and, therefore, was not printed in the New Jersey Register.

2. The change in structure of the definition of treatment was made to move that part of the definition which was regulatory in nature to a more appropriate section of the chapter (N.J.A.C. 6:29-9.3(c)5).

3. Failure by a parent or guardian to obtain the second physician's report required by N.J.S.A. 18A:40A-12 results in pupil non-attendance at school. N.J.A.C. 6:29-9.5(a)8 clarifies the statutory implications of this sequence of events.

COMMENT: One organization submitted the following question:

Does the language in N.J.A.C. 6:29-9.3(c)5 regarding appropriate treatment providers include licensed school psychologists?

RESPONSE: Yes, the language at N.J.A.C. 6:29-9.3(c)5 regarding appropriate treatment providers does include certified school psychologists if they are also trained in alcohol and other drug abuse prevention.

COMMENT: One individual spoke at the public testimony opportunity. His position was the following:

A person's religious understanding is the root of substance abuse. Therefore, taxpayers' monies should not be used for substance abuse counseling and rehabilitation. It is a violation of the separation of church and state.

RESPONSE: The decision to use or not use substances relies on a host of precipitating psychosocial factors. Most important, however, is the fact that a student under the influence of substances is physically and mentally unable to perform in school. N.J.S.A. 18A:40A-10 compels districts to provide intervention services to alcohol and other drug affected students.

#### Agency Initiated Changes

Throughout the subchapter, the Department has changed the words "drug and alcohol" to the more accurate "alcohol and other drug." At N.J.A.C. 6:29-9.3(c)5, certified substance awareness coordinators have been added as acceptable treating individuals in order to parallel the requirement for assessors in N.J.A.C. 6:29-9.3(c)4iii. Various technical changes were also made.

## SUBCHAPTER 9. SUBSTANCE ABUSE

## 6:29-9.1 Purpose

These rules are designed to provide **\*[guidance to]\* standards for\*** district boards of education in their development of policies and procedures to evaluate and treat pupils who have alcohol and **\*other drug\*[-]\*related problems** in the school setting.

## 6:29-9.2 Definitions

The following words and terms, when used in this subchapter, shall have the following meanings unless the context clearly indicates otherwise:

"Evaluation" means those procedures used to determine a pupil's need for an educational program or treatment which extends beyond the regular school program by virtue of the use of alcohol or other drugs by the pupil or the pupil's family.

"Treatment" means those programs and services offered to help a pupil because of the use of alcohol or other drugs by the pupil or the pupil's family.

## 6:29-9.3 Adoption of policies and procedures

## (a) (No change.)

(b) In adopting and implementing policies and procedures for the evaluation and treatment of **\*[drug or]\* alcohol \*or other drug-\*** affected pupils, district boards of education shall:

1. Consult with local agencies recommended by the State Department of Health; and

2. Provide for compliance with the confidentiality requirements established in Federal regulations found at 42 CFR Part II.

(c) **\*[Drug and alcohol]\* Alcohol and other drug\*** policies of district boards of education shall include, but not be limited to, the following components:

1. The roles of appropriate school staff when handling a variety of possible **\*[drug or]\* alcohol \*or other drug-\***related situations involving pupils on school property or at school functions;

2. Specific procedures, sanctions and due process provisions for violations of the **\*[drug and]\* alcohol \*and other drug\*** policy requiring disciplinary action by the district board of education. The sanctions should be graded according to the severity of the offense;

3. Specific procedures to govern instances where emergency room services are required in treating alcohol or **\*other\* drug-\***affected pupils;

4. The provision of evaluation services for pupils who are affected by **\*[drug or]\* alcohol \*or other drug\*** use. These services shall include any of the following:

i. Examination by a physician for the purpose of diagnosing whether the pupil is under the influence of alcohol and/or other drugs;

ii. Evaluation by the child study team to determine a pupil's eligibility for special education and/or related services when the pupil has been identified as potentially educationally handicapped;

iii. Assessment by individuals who are certified by the New Jersey State Board of Examiners as substance awareness coordinators or by individuals who are appropriately certified by the New Jersey State Board of Examiners and trained in alcohol **\*[and]\* \*and other\*** drug abuse prevention; and/or

iv. Referral to a community agency approved by the County Local Advisory Council on Alcoholism and Drug Abuse or the State Department of Health<sup>[.]\*\*;</sup>

5. The provision of treatment services for pupils who are affected by **\*[drug or]\* alcohol \*or other drug\*** use. Treatment shall be provided by individuals who are **\*certified by the New Jersey State Board of Examiners as substance awareness coordinators or by individuals who are\*** appropriately certified by the New Jersey State Board of Examiners and trained in alcohol **\*[or]\* \*and other\*** drug abuse prevention. These programs and services shall include any of the following:

i. Provisions for a program of instruction, counseling and related services provided by the district board of education while a pupil is receiving medical or therapeutic care for a diagnosed **\*[drug or]\* alcohol \*or other drug\*** dependency problem;

ii. Referral to a community agency approved by the County Local Advisory Council on Alcoholism and Drug Abuse or the State Department of Health;

iii. Providing support services for pupils who are in care or returning from care for **\*[drug and]\* alcohol \*and other drug\*** dependency; and/or

iv. A special class or course designed to meet the needs of pupils with **\*[drug or]\* alcohol \*or other drug\*** use problems;

6. Procedures for cooperating with law enforcement drug operations and activities on or near school property in accordance with the provisions established in N.J.A.C. 6:3-6; and

7. Provisions for the establishment of parent/guardian substance abuse educational programs offered at times and places convenient to the parents of the district on school premises or other facilities.

(d) The policies and procedures for the evaluation and treatment of **\*[drug and]\* alcohol \*and other drug-\***affected pupils developed under this section shall be reviewed and approved by the Department of Education.

## 6:29-9.4 Review and availability of policies and procedures

(a) Each district board of education shall establish an annual process to review the effectiveness of its alcohol and **\*other\* drug** policies and procedures. The district board of education shall solicit community input as well as consult with local agencies recommended by the State Department of Health in the review process.

(b) **\*[Drug and alcohol]\* Alcohol and other drug\*** policies and procedures for discipline, evaluation, and treatment of pupils shall be made available annually to all school staff, pupils, and parents or guardians.

## 6:29-9.5 Reporting, notification and examination procedures

(a) In instances involving alcoholic beverages, controlled dangerous substances or any chemical or chemical compound as identified in N.J.A.C. 6:29-9.3(a), the following shall apply:

1. Any professional staff member to whom it appears that a pupil may be under the influence of alcoholic beverages or **\*other\* drugs** on school property or at a school function shall report the matter as soon as possible to the school nurse or medical inspector and the principal.

i. In the absence of the principal, his or her designee shall be notified<sup>[.]\*\*;</sup> and\*

ii. (No change.)

2.-5. (No change.)

6. If the written report of the medical examination is not submitted to the parent or guardian **\*[and]\* \*,\* principal and chief school administrator** within 24 hours, the pupil shall be allowed to return to school until such time as a positive diagnosis of alcohol or other drug use is received.

7. If there is a positive diagnosis, from the medical examination, indicating that the pupil is under the influence of alcoholic beverages or **\*other\* drugs**, the pupil shall be returned to the care of a parent or guardian as soon as possible. Attendance at school shall not resume until a written report has been submitted to the parent or guardian of the pupil, the principal and chief school administrator from a physician who has examined the pupil to diagnose alcohol or **\*other\* drug** use. The report shall certify that substance abuse no longer interferes with the pupil's physical and mental ability to perform in school. In addition, the staff member shall complete the Violence, Vandalism and Substance Abuse Incident Report.

8. Refusal or failure by a parent to comply with the provisions of N.J.S.A. 18A:40A-12 shall be deemed a violation of the compulsory education (N.J.S.A. 18A:38-25 and 18A:38-31) and/or child neglect (N.J.S.A. 9:6-1 et seq.) laws.

9. While the pupil is at home because of the medical examination or after his or her return to school, the school may require additional evaluation for the purpose of determining the extent of the pupil's alcohol or **\*other\* drug** use and its effect on his or her school performance.

10. The district's policy shall provide for the evaluation and treatment of pupils whose use of alcohol and other drugs has affected their school performance or who possess or consume alcohol or **\*other\* drugs** in school or at school functions.

11. Any staff member who reports a pupil to the principal or his or her designee in compliance with the provisions of this subsection shall not be liable in civil damages as a result of making such a report as specified in N.J.S.A. 18A:40A-13 and N.J.S.A. 18A:40A-14.

6:29-9.6 Curriculum and instruction

(a) Each school district having kindergarten through sixth grades shall incorporate into its curriculum at each grade level \*[drug and] alcohol \*and other drug\* education appropriate for the pupil's age and maturity, in accordance with Department of Education Chemical Health Guidelines \*pursuant to N.J.S.A. 18A:40A-1\*. These guidelines are available through the New Jersey State Department of Education, 225 West State Street, CN 500, Trenton, New Jersey 08625.

(b) Each school district having seventh through twelfth grades shall incorporate into its curriculum at each \*seventh through twelfth\* grade level a minimum of 10 clock hours per school year of \*[drug and] alcohol \*and other drug\* education in accordance with Department of Education Chemical Health Guidelines\*, pursuant to N.J.S.A. 18A:40A-1\*.

(a)

**STATE BOARD OF EDUCATION**

**Statewide Assessment**

**Readoption with Amendments: N.J.A.C. 6:39-1**

Proposed: June 19, 1989 at 21 N.J.R. 1605(a).

Adopted: August 2, 1989 by Saul Cooperman, Commissioner, Department of Education; Secretary, State Board of Education.

Filed: August 14, 1989 as R.1989 d.479, with substantive and technical changes not requiring additional public notice and comment (see N.J.A.C. 1:30-4.3).

Authority: N.J.S.A. 18A:4-15, 18A:4-24, and 18A:7A-1 et seq.

Effective Date: August 14, 1989, Readoption; September 5, 1989, Amendments.

Expiration Date: August 14, 1994.

**Summary of Public Comments and Agency Responses:**

**No comments received.**

Upon adoption, the Department has added the word "only" to N.J.A.C. 6:39-1.4(b)1 for clarification, and deleted an unnecessary comma in N.J.A.C. 6:39-1.4(a)3ii.

Full text of the readoption can be found in the New Jersey Administrative Code at N.J.A.C. 6:39-1.

Full text of the amendments follows (additions to proposal indicated in boldface with asterisks \*thus\*; deletions from proposal indicated in brackets with asterisks \*[thus]\*).

6:39-1.1 Authority of the Commissioner

(a) (No change.)

(b) All such means, tests, if determined to be appropriate by the Commissioner, and examinations to be administered pursuant to this section shall be conducted by all operating school districts in New Jersey and shall meet the State criteria.

(c)-(d) (No change.)

6:39-1.2 Levels of pupil proficiency

(a) The State Board of Education, after consultation with the Commissioner, shall establish uniform Statewide levels of pupil proficiency in reading, writing and mathematics skills on the Statewide assessment instruments pursuant to N.J.S.A. 18A:17A-6 and for assessments in those grades required for district certification.

(b) For other grades that are not administered the Statewide assessment instruments and are not considered for district certification, the Department of Education shall establish equivalent standards of pupil proficiency on tests which meet State criteria and measure performance in reading, writing and mathematics skills.

(c) All pupils performing below the established levels of pupil proficiency in reading, writing and mathematics skills, as determined

by (a) and (b) above, shall be provided appropriate instructional services according to the district's basic skills improvement plan, pursuant to N.J.S.A. 18A:7A-6.

1. A waiver of this requirement may be granted if the program of needs assessment conducted pursuant to N.J.A.C. 6:8-7.1(b)1 and 4 clearly demonstrates such enrollment is unnecessary as certified by the chief school administrator.

6:39-1.4 Dissemination of information

(a) Dissemination of information procedures relative to basic skills proficiency in reading, writing, and mathematics as measured by the High School Proficiency Test (HSPT) shall be as follows:

1.-2. (No change from proposal.)

3. Rosters of pupil performance for tests developed by the Department of Education shall be distributed to chief school administrators, as indicated in (a)2 above, in such a manner as to provide a 30-day interpretation period prior to reporting to the district board of education and to the public. Following this 30-day period, the Commissioner shall make available to the public reports about each district which at a minimum shall list the number of pupils tested and percentage of pupils at or above the established levels of pupil proficiency:

- i. By grade and by test for tests developed by the Department; and
- ii. By grade\*[,]\* for certain other tests administered by each district, as deemed appropriate by the Commissioner.

4.-9. (No change.)

(b) Dissemination of information procedures relative to the Statewide tests of the core course proficiencies identified in N.J.A.C. 6:39-1.3(a) shall be as follows:

1. Notwithstanding the provisions of N.J.A.C. 6:3-2, individual pupil data shall be released \*only\* to the pupil, his or her parent(s) or legal guardian, and school personnel and school officials deemed appropriate by the Commissioner.

2.-6. (No change.)

**ENVIRONMENTAL PROTECTION**

(b)

**DIVISION OF WATER RESOURCES**

**Notice of Rule Invalidity**

**Water Supply Critical Areas; General Reduction of Privilege to Withdraw Water N.J.A.C. 7:19-6.10(c) and (d)2**

Take notice that the Superior Court of New Jersey, Appellate Division, in *In the Matter of Water Supply Critical Area No. 2*, 233 N.J. Super. 280 (App. Div. 1989), held invalid N.J.A.C. 7:19-6.10(c) and (d)2, which provided that the Department of Environmental Protection, acting on its own without the need for a gubernatorial declaration of a water supply emergency, may reduce the privilege given to users to withdraw water under certain circumstances, "[w]ithin water supply critical areas of the type described in [N.J.A.C. 7:19-6.10(a)1, 2 and 3], respectively.

The decision found these provisions to be without statutory authority. The Water Supply Management Act of 1981, N.J.S.A. 58:1A-1 to 17, empowers the Commissioner of the Department of Environmental Protection during the duration of a state of water emergency to order any user or distributor to reduce by a specified amount the use or distribution of any water supply. The Court concluded that the Commissioner "may exercise this power only after the Governor acts by executive order and declares a state of water emergency". As the rule provisions did not require that such a state of water emergency be declared before water usage reductions could be ordered, the Court held them invalid for lack of statutory authority.

This notice is provided by the Office of Administrative Law pursuant to N.J.A.C. 1:30-1.13.

**HEALTH****(a)****HOSPITAL REIMBURSEMENT****Procedural and Methodological Regulations  
Commission Fees****Adopted Amendment: N.J.A.C. 8:31B-3.66**

Proposed: June 19, 1989 at 21 N.J.R. 1606(a).

Adopted: August 11, 1989 by Molly Joel Coye, M.D., M.P.H.,  
Commissioner, Department of Health (with approval of the  
Health Care Administration Board).Filed: August 14, 1989 as R.1989 d.472, **without change.**Authority: N.J.S.A. 26:2H-1 et seq., specifically 26:2H-5b and  
26:2H-18d.

Effective Date: September 5, 1989.

Expiration Date: October 15, 1990.

**Summary of Public Comments and Agency Responses:**

COMMENTER: St. Joseph's Hospital and Medical Center

COMMENT: The Department proposes to change the Hospital Rate  
Setting Commission's fee from a ceiling of \$2.00 to \$5.00 per adjusted  
admission. The actual fee would be proposed to the Commission based  
on projected expenses associated with the hospital rate setting system.  
Although the commenter feels that a 150 percent increase in the ceiling  
is significant, it is their understanding that the Commission will likely  
object its fees below the proposed ceiling.RESPONSE: As referenced by the commenter, the actual fee charged  
will be determined by the Hospital Rate Setting Commission and will  
be based on the reasonable costs of operating an all payer hospital rate  
setting system. It is anticipated that the fee for 1990 will be below the  
proposed ceiling.

COMMENTER: U.S. Health Care

COMMENT: U.S. Health Care opposes the amendment as proposed.  
Concern was expressed that health care costs have continued to rise  
in New Jersey, despite the existence of the Hospital Rate Setting Com-  
mission. The proposed amendment represents a significant actual dollar  
impact on HMO-NJ. The adoption of the proposed amendment defeats the  
purpose of managed health care, which is to control costs.RESPONSE: The Department of Health believes that the existence of  
the all payer hospital rate setting system in New Jersey has helped to  
control costs. New Jersey hospital costs are estimated to be quite low  
compared to the average hospital cost in other states, as referenced in  
the Association's 1988 Annual Report: "... the rate of increase in New  
Jersey hospital costs has been among the lowest nationwide: From  
1981-86 New Jersey hospitals ranked 44th of all states and D.C. in rate  
of overall cost increases." The goal of the rate setting system is to control  
costs, which is consistent with the expressed desires of U.S. Health Care  
as well as other payers.New Jersey's acute care hospital industry represents approximately \$5  
billion per year in health care expenditures which are regulated by the  
Department.The maximum amount of revenue which could potentially be generated  
by an increase in the Hospital Rate Setting Commission fee ceiling to  
the \$5.00 level would represent no more than .1 percent of the total health  
care expenditures in the State. This is a small percentage of costs, when  
compared to the accrued benefits of an effective cost containment system.  
The anticipated minor increase in cost to payers, related to this amend-  
ment, is significantly less than the costs that payers would potentially bear  
in the absence of any cost containment system.

Full text of the adoption follows.

**8:31B-3.66 Commission fees**(a) A charge of up to \$5.00 per adjusted admission, as defined by  
the American Hospital Association, for each adjusted admission in  
the year of the current cost base, shall be assessed each institution  
for which the Commission determines a preliminary cost base.

(b) (No change.)

**(b)****HOSPITAL REIMBURSEMENT****Procedural and Methodological Regulations  
Reconciliation: Hospitals****Adopted Amendment: N.J.A.C. 8:31B-3.73**

Proposed: June 19, 1989 at 21 N.J.R. 1606(b).

Adopted: August 11, 1989 by Molly Joel Coye, M.D., M.P.H.,  
Commissioner, Department of Health (with approval of the  
Health Care Administration Board).Filed: August 14, 1989 as R.1989 d.471, **with a technical change**  
not requiring additional public notice and comment (see  
N.J.A.C. 1:30-4.3).Authority: N.J.S.A. 26:2H-1 et seq., specifically 26:2H-5b and  
26:2H-18d.

Effective Date: September 5, 1989.

Expiration Date: October 15, 1990.

**Summary of Changes Upon Adoption:**The Department has made clear that the authority to approve adjust-  
ments rests with the Hospital Rate Setting Commission rather than the  
Department.**Summary of Public Comments and Agency Responses:**COMMENTERS: Christ Hospital; Cohen, Shapiro, Polisher,  
Shiekman, and Cohen, on behalf of Bergen Pines County Hospital; New-  
comb Medical Center; and Wayne General HospitalCOMMENT: The commenters requested clarification of N.J.A.C.  
8:31B-3.73(a)5ii, which states, "The Department of Health may limit rate  
adjustments if a hospital has not demonstrated a good faith effort to  
obtain from Medicare the appropriate level of reimbursement." Specific  
requests are:

1. Definitions of "good faith effort" and "appropriate level of reim-  
bursement."
2. Detail about how the Department will determine if such an effort  
has been exercised by the hospital.
3. Detail about the method to be used by the Department to arrive  
at the amount for limiting rate adjustments.
4. Clarification of authority to approve such adjustments.

RESPONSE: 1. The intent of N.J.A.C. 8:31B-3.73(a)5ii is to en-  
courage hospitals to collect all of the Medicare revenue to which they  
are entitled. This means: all allowed Medicare reimbursement, such as  
Medicare bad debt; disproportionate share adjustments and excluded unit  
status where appropriate; PPS appeals; and pass-throughs such as capital  
and medical education. Pursuit of all available channels to receive ap-  
propriate Medicare reimbursement is encouraged, to protect the remain-  
ing payers who participate in Chapter 83 from having Medicare reim-  
bursable costs shifted to them.2. The Department will determine if hospitals have exercised a good  
faith effort to obtain Medicare reimbursement by reviewing documenta-  
tion provided by the hospital, Health Care Financing Administration, and  
the fiscal intermediary.3. The Final Reconciliation Methodology, to be approved by the Hos-  
pital Rate Setting Commission, shall specify the means of determining  
areas where such good faith efforts have not been applied.4. The Department concurs that the authority to approve such adjust-  
ments rests with the Hospital Rate Setting Commission. The regulatory  
language has been changed to reflect this.COMMENTERS: Newcomb Medical Center, Wayne General Hospi-  
talCOMMENT: The proposed amendment does not address the mechan-  
ism for cash flow relief for any Medicare inpatient shortfalls.RESPONSE: The cash flow mechanism is separate from, but as-  
sociated with, final reconciliation. The recognition of Medicare payment  
differences as an element of final reconciliation allows for cash flow  
adjustments during the rate year. The Department believes that authority  
for such adjustments is provided at N.J.A.C. 8:31B-3.71. In accordance  
with cash flow procedure, the Medicare Shortfall Cash Flow Method-  
ology was approved by the Hospital Rate Setting Commission on April  
19, 1989 and has already been implemented.

COMMENTER: Wayne General Hospital

COMMENT: "The proposed regulation deals with discharges (inpa-  
tients) after January 1, 1989. How will the Department deal with shortfalls

on Medicare outpatients that hospitals may experience during a particular year?"

RESPONSE: The Department previously developed a separate methodology to address outpatient shortfalls which is intended to be continued in 1989.

COMMENTER: St. Joseph's Hospital and Medical Center

COMMENT: "Medicare's inclusion of Graduate Medical Education/Severity and Disproportionate Share Adjustment are components not found in Chapter 83. As such, it is our opinion that these adjustments should be retained by the Hospital and not carved out of net revenue collected from Chapter 83."

RESPONSE: It would be inappropriate to include some, but not all, components of Medicare revenue when comparing payment differences between Chapter 83 and Medicare. Graduate Medical Education/Severity are indeed recognized in Chapter 83 through a continuous GME methodology recently adopted, through an updated GROUPE, and through the recognition of case-mix that is built into the DRG system. Equity dictates that if Medicare shortfalls are restored to hospitals, the scarce areas of Medicare overpayment should also be netted against Chapter 83 reimbursement.

COMMENTER: Touche Ross & Co.

COMMENT: The following comment refers to N.J.A.C. 8:31B-3.73(a)5:

"This section should be expanded to include, not only the rate year revenue, but also, commission-approved revenue for prior year Final Reconciliations."

RESPONSE: N.J.A.C. 8:31B-3.73(a)6 provides for adjustments necessitated by Gramm-Rudman-Hollings mandated reductions for rate years prior to 1989. Such reductions will be recognized in the final reconciliation process for 1986, 1987, and 1988. Any resulting under or over collections would continue to be treated in future years' rates as adjustments to participating payers.

COMMENTER: Blue Cross

COMMENT: The Appellate Division, in *New Jersey Hospital Ass'n v. New Jersey State Dep't of Health*, 227 N.J. Super. 557 (App. Div. 1988), remanded this issue to the Hospital Rate Setting Commission to review restoration of the Gramm-Rudman-Hollings reductions on a case by case basis. This regulation is neither appropriate nor necessary.

RESPONSE: The Department has been advised by the Attorney General's Office that a rule is required to conform with the specific directives of the Appellate Division. According to the Attorney General's Office, the express language of the court's decision repeatedly provides that rulemaking procedures must be invoked on remand. Therefore, this rule has been proposed and adopted by the Department, pursuant to the rulemaking powers in N.J.S.A. 26:2H-5(b), 26:2H-18 and 26:2H-18.1.

COMMENTER: Health Insurance Association of America

COMMENT: There should be no across-the-board restorations of the Gramm-Rudman-Hollings reductions to hospital rates. The reductions have been adequately addressed through restoration of the uncompensated care portion and allowance for individual appeals.

RESPONSE: It is the Department's interpretation of the Appellate Division's decision that the record did not establish any basis for reducing hospital rates by the amount of the Gramm-Rudman-Hollings reduction, especially because the rates had initially been approved by the Hospital Rate Setting Commission. Given the presumption that the rates as set by the Hospital Rate Setting Commission are reasonable, the Department believes that the reductions cannot be justified by any existing principles of the rate setting system as established by statute and therefore recommends that they be restored, as proposed and adopted by this rulemaking.

Full text of the adoption follows (additions to proposal indicated in boldface with asterisks \*thus\*; deletions from the proposal indicated in brackets with asterisks \*[thus]\*):

#### 8:31B-3.73 Reconciliation: Hospitals

(a) Following receipt of actual patient specific information pursuant to Rules on Hospital Reporting for Uniform Bill—Patient Summaries (in-patient) or N.J.A.C. 8:31A-10.7, whichever is appropriate: determination of actual case-mix as determined the same GROUPE used to establish rates, and calculation of the actual economic factor, the Commissioner shall determine consistent with the Commission's Order, for each hospital, for the calendar year or rate period, whichever is appropriate, reconciliation:

1.-4. (No change.)

5. Nonparticipating payers: For discharges after January 1, 1985 to the extent that payments made by or on behalf of Medicare patients are different than Commission-approved revenues for a rate year, the Hospital Rate Setting Commission will adjust rates to assure that New Jersey hospitals will continue to receive their approved revenues.

i. For purposes of final reconciliation, Medicare revenue will be defined as revenue accrued during the rate year including deductible: coinsurance, and all pass-through reimbursement such as direct teaching and capital, as adjusted by the Notice of Program Reimbursement (NPR) issued by the fiscal intermediary at final settlement.

ii. The \*[Department of Health]\* **Hospital Rate Setting Commission** may limit rate adjustments if a hospital has not demonstrated a good faith effort to obtain from Medicare the appropriate level of reimbursement.

6. To the extent that Medicare payments for the 1986, 1987 and 1988 rate years are different than Commission-approved revenues: due to Gramm-Rudman-Hollings mandated reductions, the Hospital Rate Setting Commission will adjust rates to assure that New Jersey hospitals will receive their approved revenues for those rate years: For purposes of final reconciliation, rate year Medicare revenue will be defined as in N.J.A.C. 8:31B-3.73(a)5i above.

## HIGHER EDUCATION

### (a)

#### BOARD OF DIRECTORS OF EDUCATIONAL OPPORTUNITY FUND

##### Financial Eligibility for Undergraduate Grants

##### Adopted Amendment: N.J.A.C. 9:11-1.5

Proposed: June 5, 1989 at N.J.R. 1489(a).

Adopted: August 11, 1989 by the Board of Directors of the

Educational Opportunity Fund, Judith Cambria, Chairperson  
Filed: August 14, 1989 as R.1989 d.468, with a substantive change not requiring additional public notice and comment (see N.J.A.C. 1:30-4.3).

Authority: N.J.S.A. 18A:71-33.

Effective Date: September 5, 1989.

Expiration Date: April 17, 1994.

##### Summary of Public Comments and Agency Responses:

**No comments were received.**

The Board is changing the effective academic year for the grants set forth within this section to reflect their applicability to the upcoming academic year. The academic year originally listed in the proposal was erroneously stated.

Full text of the adoption follows (additions to proposal indicated in boldface with asterisks \*thus\*; deletions from proposal indicated in brackets with asterisks \*[thus]\*).

#### 9:11-1.5 Financial eligibility for undergraduate grants

(a) A dependent student is financially eligible for an initial E.O.F. grant if the gross income of his or her parent(s) or guardian(s) does not exceed the applicable amount set forth below in the E.O.F. Income Eligibility Scale. Where the dependent student's parent(s) or guardian(s) are receiving welfare as the primary means of family support, the student is presumed to be eligible without regard to the amount of primary welfare support.

##### 1. EOF Dependent Student Eligibility Scale:

| Applicants With a Household of: | Gross Income (Not to Exceed): |
|---------------------------------|-------------------------------|
| 2 persons                       | \$15,130                      |
| 3                               | 17,270                        |
| 4                               | 19,410                        |
| 5                               | 21,550                        |
| 6                               | 23,690                        |
| 7                               | 25,830                        |

2. For each additional member of the household, an allowance of \$2,140 shall be added to this amount in order to determine eligibility for E.O.F. for the \*[1988-89]\* \*1989-90\* Academic Year. This allowance shall be adjusted annually to reflect changes in the Standard Maintenance Allowance as published by the College Scholarship Service. In addition, the gross income level for each household size also shall be adjusted to reflect the change in the annual Standard Maintenance Allowance.

3. The E.O.F. Executive Director shall annually inform institutions of adjustments to the Income Eligibility Scale, in accordance with the Standard Maintenance Allowance published by the College Scholarship Service.

(b)-(c) (No change.)

(d) An independent student is financially eligible for an E.O.F. grant providing his or her gross annual income (including spouse) for the calendar year prior to the academic year for which aid is requested and the calendar year during which aid is received does not exceed the following schedule:

1. \$9,260 family size (including student) 1;
2. \$11,400 family size (including spouse) 2;
3. \$13,540 family size (including spouse) 3;
4. \$15,680 family size (including spouse) 4;
5. Add \$2,140 for each additional dependent. This amount should be adjusted annually to reflect changes in the Independent Student Allowance as published by the College Scholarship Service.

6. An independent student who received welfare as the primary means of family support is presumed to be eligible without regard to the amount of primary welfare support.

(e)-(g) (No change.)

## HUMAN SERVICES

### (a)

#### DIVISION OF MEDICAL ASSISTANCE AND HEALTH SERVICES

##### Notice of Administrative Correction Administration Manual

##### N.J.A.C. 10:49-1.1

**Take notice** that the Department of Human Services has discovered an error in the published text of the adopted amendment to N.J.A.C. 10:49-1.1(b)9 published in the August 7, 1989 New Jersey Register at 21 N.J.R. 2838(a). The word "eligible" in that paragraph is incorrect. As filed for proposal with the Office of Administrative Law (PRN 1989-188), the word was "ineligible," which was mistakenly published for proposal (see 21 N.J.R. 965(a)) and adoption as "eligible." This error is corrected by this notice pursuant to N.J.A.C. 1:30-2.7(a)3, since the use of "eligible" is erroneous in light of both the proposal Summary stating that no new groups of eligible individuals were proposed, which SSI eligible individuals would be, and the inappropriateness of the usage of "eligible" in the context of both the sentence itself and the purpose of the Medicaid program (see, for comparison, N.J.A.C. 10:49-1.1(b)6).

**Full text** of the corrected rule follows (additions indicated in boldface **thus**; deletions indicated in brackets [thus]):

10:49-1.1 Who is eligible for Medicaid

(a) (No change.)

(b) The following groups are eligible for medical and health services covered under the New Jersey Medicaid Program when provided in conjunction with program requirements specifically outlined in the second chapter of each service manual. The groups are not all inclusive:

1.-8. (No change.)

9. Persons [eligible] **ineligible** for Supplemental Security Income (SSI) because of requirements that do not apply under Medicaid;

10.-21. (No change.)

(c)-(g) (No change.)

### (b)

#### DIVISION OF ECONOMIC ASSISTANCE

##### Public Assistance Manual Child Support Program: Incentive Payment Methodology

##### Adopted Repeal and New Rule: N.J.A.C. 10:81-11.6

Proposed: March 20, 1989 at 21 N.J.R. 663(a).

Adopted: August 9, 1989 by Drew Altman, Commissioner,  
Department of Human Services.

Filed: August 10, 1989 as R.1989 d.465, **with substantive changes** not requiring additional public notice and comment (see N.J.A.C. 1:30-4.3).

Authority: N.J.S.A. 44:7-6 and 44:10-3; 45 CFR 303.52(b) and 305.46.

Effective Date: September 5, 1989.

Expiration Date: October 15, 1989.

##### Summary of Public Comments and Agency Responses:

**COMMENT:** One comment was received from a county welfare agency expressing concern that the incentive formula would adversely impact upon those counties having high non-AFDC child support collections. The county welfare agency requested that language be modified in accordance with Federal regulations at 45 CFR 303.52(b) for more equitable distribution of incentive monies.

**RESPONSE:** The Department agrees with the commenter and, for clarification purposes, language has been added which allows for the non-AFDC portion of the incentive plan to equal 105 percent in Fiscal Year 1988, 110 percent in Fiscal Year 1989, and 115 percent in Fiscal Year 1990, as delineated in Federal regulations. No fiscal impact is expected since the requested modification is currently observed practice.

##### Summary of Changes Subsequent to Proposal:

At N.J.A.C. 10:81-11.6(a)4, the term "benefit/cost ratio" is replaced with "collections to expenses ratio". This change is made as a result of internal Departmental review to clarify the text.

**Full text** of the adoption follows (additions to proposal indicated in boldface with asterisks \*thus\*; deletions from proposal indicated in brackets with asterisks \*[thus]\*).

10:81-11.6 Incentive payment

(a) CWAs shall receive an appropriate share of any incentive payments made to the State, based on the efficiency and effectiveness of the CWA's activities in carrying out the requirements of the Title IV-D State Plan. A portion of the incentive payments shall be computed as a percentage of the State's AFDC collections and a portion shall be computed as a percentage of non-AFDC collections. The percentages shall be computed separately for each segment, based on the ratio of the State's AFDC collections to the State's total IV-D administrative costs. The portion of the incentive payments in recognition of non-AFDC collections shall be limited by the percentage of the portion of the incentive payments paid for a specific year in recognition of its AFDC collections\*, **and shall equal 105 percent in Fiscal Year 1988, 110 percent in Fiscal Year 1989, and 115 percent in Fiscal Year 1990\***.

1. AFDC collections means support collections satisfying an assignment support obligation, including support collected by one state on behalf of individuals receiving IV-D services and parents residing in another state, which shall be treated as having been collected in full by each state.

2. Non-AFDC collections means support collections on behalf of individuals receiving Title IV-D services, satisfying a support obligation which has not been assigned via Form PA-IJ, including collections made by one state on behalf of individuals receiving IV-D services and parents residing in another state. Such interstate collections shall be treated as having been collected in full by each state.

3. Total IV-D administrative costs means total IV-D expenditures claimed by a state in a specified fiscal year, excluding fees paid by individuals, recovered costs and program income, such as interest earned on collections. Another exclusion from administrative costs shall be laboratory fees incurred in determining paternity.

4. In calculating the amount of incentive payments, only those AFDC and non-AFDC collections distributed and expenditures claimed by the State in the fiscal year shall be used to determine the incentive payment payable for a year. The methodology to be employed in the calculation of incentive payments will be the same for both program segments (AFDC and non-AFDC); however, the incentive payment for non-AFDC, as noted above, cannot exceed the amount earned for AFDC collections. Each county will receive its share of the State's incentive payments, based on the **\*[benefit/cost ratio]\* \*collections to expenses ratio\*** truncated at the first decimal place. This methodology requires the determination of the average **\*[benefit/cost ratio]\* \*collections to expenses ratio\*** among the counties. The standard deviation from the average is then determined. A scale is established and a value of six percent is assigned to the State average. For each movement of a full + 1/2 standard deviation by a county's **\*[benefit/cost ratio]\* \*collections to expenses ratio\***, that county will be entitled to one percent more of incentive payment. Any resultant surplus will be distributed according to the counties' proportionate share of the total qualified caseload.

(b) The Federal Office of Child Support Enforcement (OCSE) will estimate the total incentive to be received by a state for the upcoming fiscal year. In the quarterly collection report, the State will estimate the total payment, thus reducing the amount to be paid to the Federal government to reimburse its share of assistance payments, IV-A and Foster Care maintenance payments. At the end of a fiscal year, the OCSE will determine if the estimated incentive payments were correct and, if not, adjustments will be made accordingly.

1. Collections made in one jurisdiction for another jurisdiction shall be forwarded to the originating jurisdiction no later than 10 days after collection was received.

i. States and other jurisdictions must have a identifying code for interchange procedures.

(a)

## DIVISION OF ECONOMIC ASSISTANCE

### Food Stamp Program

### Miscellaneous Program Requirements

**Adopted Amendments: N.J.A.C. 10:87-2.13, 2.30, 2.33, 2.36, 2.37, 4.8, 5.9 and 6.2**

**Adopted Repeal and New Rule: N.J.A.C. 10:87-9.7**

Proposed: June 19, 1989 at 21 N.J.R. 1636(a).

Adopted: August 9, 1989 by Drew Altman, Commissioner, Department of Human Services.

Filed: August 10, 1989 as R.1989 d.464, with technical changes not requiring additional public notice and comment (see N.J.A.C. 1:30-4.3).

Authority: N.J.S.A. 30:4B-2, 54 FR 6990, the Hunger Prevention Act of 1988 (P.L. 100-45), the Wartime Relocation of Civilians Act (P.L. 100-33), and the Anti-Drug Abuse Act of 1986 (P.L. 99-570).

Effective Date: September 5, 1989.

Operative Date: October 1, 1989.

Expiration Date: January 27, 1994.

### Summary of Public Comments and Agency Responses:

Comments were received from a county welfare agency as follows:

COMMENT: The agency noted that it might encounter difficulty in meeting the five-day and 30-day processing standards applied to expedited and non-expedited food stamp applications, respectively, if Social Security Administration (SSA) field offices do not transmit those applications to the CWA immediately.

RESPONSE: The regulations at 7 CFR 273.2, which were published in the January 30, 1989 edition of the Federal Register, mandated that the food stamp application processing standards for prerelease applicants begin on the date of the applicant's release from the institution. The preamble of those regulations noted that SSA field offices will notify county welfare agencies of the impending release of each applicant from an institution, and that SSA field offices anticipate completion and forwarding of the prerelease applications within one working day.

COMMENT: The agency noted that the regulatory reference at N.J.A.C. 10:87-9.7(d)li which reads "(f3)" should be "(f4)".

RESPONSE: The reference has been corrected.

COMMENT: The agency noted that it would have difficulty complying with the 10-day replacement of benefits timeframes cited at N.J.A.C. 10:87-9.7(d) when it must ascertain the validity of each request for replacement prior to issuing the replacement.

RESPONSE: N.J.A.C. 10:87-9.7(e) and (f) both require the CWA to determine the validity of a household's request for replacement of benefits before issuing the replacement, but only "... to the extent possible ...". The CWA cannot delay the replacement beyond the 10-day replacement issuance timeframe pending completion of its investigation.

### Summary of Changes Subsequent to Proposal:

At N.J.A.C. 10:87-6.2(c) and 9.7(a), proposal printing errors are corrected. At N.J.A.C. 10:87-9.7(c)3, a technical correction replaces the word "State" with "CWA" to delineate the correct procedure. At N.J.A.C. 10:87-9.7(d)li, a reference is corrected.

Full text of the adoption follows (additions to proposal indicated in boldface with asterisks **\*thus\***; deletions from proposal indicated in brackets with asterisks **\*[thus]\***).

### 10:87-2.13 Filing an application

(a) Households must file a food stamp application by submitting the appropriate form to the food stamp office in person, through an authorized representative, or by mail. The amount of time for the CWA to deliver benefits is calculated from the date the application is filed in the food stamp office designated to accept the household's application (see N.J.A.C. 10:87-2.30 and 2.31). Households subject to SSI joint processing (see N.J.A.C. 10:87-2.12(a)3) must file a food stamp application by submitting the appropriate form to the SSA/DO in person, through an authorized representative, or by mail. The amount of time for the CWA to deliver benefits is calculated from the date the application is filed in the SSA/DO designated to accept the household's application (see N.J.A.C. 10:87-2.30). Residents of public institutions who jointly apply for food stamps and SSI under SSA's Prerelease Program for the Institutionalized shall have their date of release from the institution considered as the date of application for food stamp purposes.

(b)-(f) (No change.)

### 10:87-2.30 Normal processing standard

(a) The CWA shall provide eligible households that submit a complete application an opportunity to participate as soon as possible, but not later than 30 calendar days after the application was filed. An application is considered filed the day the appropriate food stamp office receives the application containing the applicant's name and address and signed by either a responsible member of the household or the household's authorized representative. For SSI jointly processed households, the application shall be considered filed for normal processing purposes when the signed application is received by the SSA district office. For residents of public institutions who jointly apply for food stamps and SSI under SSA's Prerelease Program for the Institutionalized, the application shall be considered filed for normal processing purposes when the resident is released from the institution. Households entitled to expedited processing are specified in N.J.A.C. 10:87-2.32 et seq.

(b) Opportunity to participate: An opportunity to participate consists of providing households with an ATP and having an issuance facility open and available for the household to obtain its allotment. If the ATP is mailed, two days shall be allowed for delivery before determining if the household has been provided an opportunity to participate. A household has not been provided an opportunity to participate within 30 days of application if the ATP is mailed on the 29th or 30th day. Neither has an opportunity to participate been provided if the ATP is mailed on the 28th day but no issuance facility is open on the 30th day where the household can obtain coupons. The CWA must mail the ATP at least two days in advance of the 30th day and assure that the ATP can be transacted after it is received but before the 30th day expires. The CWA shall ensure that each certified household is provided an ID card concurrent with the initial issuance of food stamp benefits to the household.

1. Any ATP issued after the 19th day of the month shall not expire until the end of the following month.

2. A household shall be entitled to replaced benefits, lost as a result of being unable to obtain a particular allotment, if the validity period of the ATP expires between the time the household requested a replacement ID card and the delivery of that card to the household.

(c) (No change.)

#### 10:87-2.33 Expedited service processing standards

(a) For households entitled to expedited service, the CWA shall make available to the recipient an ATP card not later than the fifth calendar day following the date an application was filed in the appropriate food stamp office. For residents of public institutions who apply for SSI under SSA's Prerelease Program for the Institutionalized, expedited benefits shall be made available within five calendar days following the date of the resident's release from the institution. The CWA shall ensure that a reasonable opportunity for ATP redemption exists on the day of issuance within the time limits specified in this section.

(b)-(e) (No change.)

#### 10:87-2.36 Categorically eligible AFDC/SSI households

(a)-(n) (No change.)

(o) Any household determined AFDC/SSI eligible which is categorically eligible within the 30-day food stamp processing time shall be provided benefits in accordance with N.J.A.C. 10:87-2.30. Benefits shall be prorated in accordance with current procedures.

(p)-(r) (No change.)

#### 10:87-2.37 Procedures for SSI jointly processed households

(a) (No change.)

(b) Initial application at the Social Security District Office (SSA/DO): The SSA/DO will inform households eligible for SSI joint processing (see N.J.A.C. 10:87-2.12(a)3) of their right to apply for food stamps at the SSA/DO without going to the food stamp office and will refer all other households to the appropriate food stamp office. The SSA/DO will accept and complete FSP-901A forms received from households eligible for SSI joint processing and forward them within one working day to the appropriate CWA. Along with the FSP-901A, the SSA/DO will forward a Social Security Administration Transmittal for Food Stamp Applications (Form SSA-4233) which documents all verification obtained by the SSA employee.

1.-2. (No change.)

3. Residents of public institutions who apply for SSI under SSA's Prerelease Program for the Institutionalized may complete a joint application for SSI/FS prior to release from the institutions, and are subject to the same provisions applicable to all other jointly processed SSI households, with the following exceptions:

i. The 30-day processing standard described in N.J.A.C. 10:87-2.30 to deliver benefits to a prerelease applicant shall be based upon the date the individual is released from the institution, rather than the date the application is filed at the CWA.

ii. A prerelease applicant who is entitled to expedited service shall be provided food stamp benefits no later than the fifth calendar day following the date of release from the institution.

iii. A prerelease applicant's benefit level for the initial month of certification shall be based on the day of the month the resident is released from the institution.

(c)-(h) (No change.)

#### 10:87-4.8 Identification of resource exclusions

(a) Only the following shall be classified as resource exclusions by the CWA:

1.-16. (No change.)

17. Resources excluded by Federal law: Resources which are excluded for food stamp purposes by express provision of Federal statute. The following is a listing of resources excluded by Federal statute:

i.-xiii. (No change.)

xiv. Payments received under the Wartime Relocation of Civilians Act (P.L. 100-383).

18.-19. (No change.)

#### 10:87-5.9 Identification of income exclusions

(a) Only the following shall be excluded from household income; no other income shall be excluded.

1.-14. (No change.)

15. Income excluded by Federal law: Any income that is specifically excluded by any other Federal statute from consideration as income for the purpose of determining eligibility for the Food Stamp Program shall be excluded. The following qualify under this provision.

i.-vi. (No change.)

vii. Earned income tax credits:

(1) Earned income tax credits received as a result of Public Law 95-600, the Revenue Act of 1978, which are received before January 1, 1980; and

(2) Earned income tax credits made as advance payments which are received on or after January 1, 1989.

viii.-xiv. (No change.)

xv. Payments received under the Wartime Relocation of Civilians Act (P.L. 100-383).

#### 10:87-6.2 Month of application

(a) The month of application for all households is the calendar month in which the household filed its application. For those prerelease applicants described at N.J.A.C. 10:87-2.37(b)3, the month of application shall be the date of release from the institution. This includes households submitting an application following any period of time during which the household was not certified for participation in the program. In most cases, the month of application will be the initial month of the household's certification period (see definition of initial month in (b) below). The CWA shall determine a household's eligibility during the month of application based on the household's circumstances for the entire calendar month in which the household filed its application, even if the household filed its application on the last day of that calendar month.

(b) (No change.)

(c) Determining benefit level for initial month: A household's benefit level for the initial month will be based on the day of the month it applies for benefits. For those prerelease applicants described in N.J.A.C. 10:87-2.37(b)3, the initial benefit shall be based on the date of each individual's release from the institution. Using a 30-day calendar month, households shall receive benefits prorated from the day of application to the end of the month. A household applying on the 31st of the month will be treated as though it applied on the 30th of the month. The \$10.00 minimum benefit for one and two person households shall be prorated. To determine the amount of the prorated allotment for the month of application the CWA shall use the Allotment Proration Table found in N.J.A.C. 10:87-12.5. If the allotment for the initial month is less than \*\$10,000\* **\*\$10.00\*** the CWA shall not issue benefits to that household.

#### 10:87-9.7 Replacement of benefits

(a) Rules on providing replacement **\*[issues]\* \*issuances\*** are as follows:

1. Subject to the restrictions in (b) below, CWAs shall provide replacement issuances to a household when the household reports that:

i. The ATP was not received or was stolen from the mail, was stolen after receipt, was destroyed in a household misfortune, or was improperly manufactured or mutilated;

ii. The coupons were not received in the mail, were stolen from the mail, were destroyed in a household misfortune, or were improperly manufactured or mutilated;

iii. Food purchased with food stamps was destroyed in a household misfortune; or

iv. The household received a partial coupon allotment in the mail.

2. CWAs shall not provide replacement issuances to households when coupons are lost, stolen or misplaced after receipt, when ATPs are lost or misplaced after receipt, when ATPs or coupons are totally destroyed after receipt in other than a disaster or misfortune, or when coupons sent by registered or certified mail are signed for by anyone residing with or visiting the household. In addition, replacement

issuances shall not be made if the household or its authorized representative has not signed and returned the household statement required in (c) below where applicable.

3. Where FNS has issued a disaster declaration and the household is eligible for emergency food stamp benefits, the household shall not receive both the disaster allotment and a replacement allotment for a misfortune.

4. In order for a replacement to be considered non-countable, the replacement must not result in a loss to the program.

(b) Rules on replacement restrictions are as follows:

1. Replacement issuances shall be provided only if a household timely reports a loss orally or in writing, and provides a statement of nonreceipt if the original ATP or allotment has not been returned to the CWA at the time of request for replacement. The report shall be considered timely if it is made to the CWA within 10 days of the date an ATP is stolen from the household, or an ATP, coupons, or food purchased with food stamps is destroyed in a household misfortune. For a claim of nondelivery by the mail, the report must be made within the period of intended use. (If the issuance was made after the 19th of the month, the period of intended use is the last day of the next month.)

2. The number of replacement issuances which a household may receive shall be limited as follows:

i. CWAs shall limit replacement issuances to a total of two countable replacements in six months for ATPs or coupons not received in, or stolen from, the mail, ATPs stolen after receipt, and partial coupon allotments. Separate limits shall not apply for each of the above types of loss.

ii. CWAs shall limit replacement issuances per household to two countable replacements in six months for ATPs or coupons reported as destroyed in a household misfortune. This limit is distinct from the limit in (b)2i above.

iii. No limit on the number of replacements shall be placed on the replacement of ATPs or coupons which were improperly manufactured or mutilated or food purchased with food stamp benefits which was destroyed in a household misfortune.

iv. The replacement issuance shall not be considered a countable replacement if:

(1) The original or replacement issuance is returned or otherwise recovered by the CWA;

(2) The original ATP is not transacted;

(3) The replacement ATP is not transacted; or

(4) The replacement is being issued due to an issuance error.

3. Replacement issuances shall be provided in the amount of the loss to the household, up to a maximum of one month's allotment, unless the issuance includes restored benefits which shall be replaced up to their full value.

(c) Rules on the household statement of nonreceipt are as follows:

1. Prior to issuing a replacement, the CWA shall obtain from a member of the household a signed statement attesting to the household's loss. This statement shall not be required if the reason for the replacement is that the original ATP or coupons were improperly manufactured or mutilated, or if the original issuance has already been returned. The required statement may be mailed to the CWA if the household member is unable to come into the office because of age, handicap or distance from the office and is unable to appoint an authorized representative.

2. If the signed statement or affidavit is not received by the CWA within 10 days of the date of report, no replacement shall be made. If the 10th day falls on a weekend or holiday, and the statement is received the day after the weekend or holiday, the CWA shall consider the statement timely received.

3. The statement shall be retained in the case record. It shall attest to the nonreceipt, theft, loss or destruction of the original issuance and specify the reason for the replacement. It shall also state that the original or replacement issuance will be returned to the \*[State agency]\* \*CWA\* if the original issuance is recovered by the household and that the household is aware of the penalties for intentional misrepresentation of the facts including, but not limited to, a charge of perjury for a false claim. In addition, the statement shall advise the household that:

i. The household may request to be placed on an alternate issuance system after one report of nonreceipt;

ii. After two reports in a six-month period of loss or theft prior to receipt, the household shall be placed on an alternate delivery system;

iii. After two reports in a six-month period of loss or theft prior to receipt and/or theft of an ATP after receipt, the CWA may delay or deny further replacements for such causes; and

iv. If the statement of nonreceipt is not signed and returned within 10 days of the date the loss was reported, the CWA shall not replace the coupons or ATP.

(d) Provisions concerning the time limits for making replacements are as follows:

1. Replacement issuances shall be provided to households within 10 days after report of nondelivery or loss (15 days if issuance was by certified or registered mail) or within two working days of receiving the signed household statement required in (c) above, whichever date is later.

i. Replacement of mutilated coupons shall be delayed until a determination of the value of the coupons can be made in accordance with \*[f(3)]\* \*(f)4\* below.

ii. If the household has already been issued the maximum allowable number of countable replacements, subsequent replacements shall be delayed until the agency has verified that the original ATP was not transacted. In a system using ATPs, it may not be known at the time of the replacement request whether prior replacements are countable replacements and, therefore, whether the household has reached its limit. In such cases, the allotment shall be restored when the CWA verifies that the limit on countable replacements has not been reached.

iii. The CWA shall deny or delay replacement issuances in cases in which available documentation indicates that the household's request for replacement appears to be fraudulent.

2. The household shall be informed of its right to a fair hearing to contest the denial or delay of a replacement issuance. Replacements shall not be made while the denial or delay is being appealed.

(e) CWAs shall comply with the following procedures in replacing issuances reported lost in the mail or stolen prior to receipt by the household:

1. Determine if the ATPs or benefits were validly issued, if they were actually mailed, and if sufficient time has elapsed for delivery or if they were returned in the mail. If a delivery of a partial allotment is reported, the CWA shall determine the value of the coupons not delivered and determine whether the report of receipt of a partial allotment is corroborated by evidence that the coupon loss was due to damage in the mail before delivery or by a discrepancy in the issuance unit's inventory;

2. Determine, to the extent possible, the validity of the request for a replacement. This includes determining whether the original issuance has been returned to the CWA, whether the original ATP has been transacted and, if so, whether the recipient's signature on the ATP matches the signature on the ID card. In a photo ID area, the CWA shall determine if the ID serial number annotated on the ATP matches the serial number on the recipient's ID card;

3. Issue a replacement in accordance with (b) through (d) above if the household is eligible;

4. Place the household on an alternate delivery system, if warranted, in accordance with (g) below; and

5. Take other action, such as correcting the address on the FAMIS file, warranted by the reported nondelivery.

(f) Upon receiving a request for replacement of an issuance reported as stolen or destroyed after receipt by the household, the CWA shall determine if the issuance was validly issued. The CWA shall also comply with all applicable provisions in (b) through (d) above, as well as the following procedures for each type of replacement:

1. Prior to replacing an ATP which was reported stolen after receipt by the household, the CWA shall determine, to the extent possible, the validity of the request for replacement. For example, the CWA may determine whether the original ATP has been transacted and, if so, whether the signature on the original ATP matches

## ADOPTIONS

that on the household statement. Where the use of a photo ID is mandated, the CWA shall determine if the ID serial number annotated on the ATP matches the serial number on the recipient's ID card. Any replacement which results in duplicate participation shall be considered a household error, and the replacement countable, when the ID serial number shown on the ATP matches the serial number on the recipient's card, unless the ID card was reported lost or stolen prior to the replacement. The CWA may require households, on a case-by-case basis, to report the theft to a law enforcement agency and to provide verification of such report.

2. Prior to replacing destroyed ATPs, coupons, or food purchased with food stamp benefits, the CWA shall determine that the destruction occurred in a household misfortune or disaster, such as, but not limited to, a fire or flood. This shall be verified through a collateral contact, documentation from a community agency including, but not limited to, the fire department or the Red Cross, or a home visit. The CWA shall provide replacements of coupons, ATPs and/or food in the actual amount of the loss, but not exceeding one month's allotment, unless the exception in (b)3 above applies.

3. Households cannot receive a replacement for coupons lost or stolen after receipt.

4. The CWA shall provide replacements for improperly manufactured or mutilated coupons or ATPs as follows:

i. Coupons received by a household, and subsequently mutilated or found to be improperly manufactured, shall be replaced in the amount of the loss to the household, but not to exceed one month's allotment. CWAs shall replace mutilated coupons when at least three-fifths of a coupon is presented by the household. The CWA shall replace improperly manufactured or mutilated coupons in accordance with N.J.A.C. 10:87—Appendix A, Section A(3).

ii. ATPs received by a household and subsequently mutilated or found to be improperly manufactured shall be replaced only if they are identifiable. "Identifiable" means that the CWA is able to determine the amount of the issuance and that the ATP was valid when the household reported that the ATP was mutilated or mismanufactured. For example, if the ATP serial number is legible, the CWA can determine from the record-for-issuance or manual authorization document log to which household the ATP was issued, the date of issuance, and the amount. Similarly, if the case number and validity period are legible, the CWA may be able to determine to whom the ATP was issued and the amount. If more than one ATP was issued to the household and the CWA cannot determine which ATP was mutilated, the replacement shall be issued in the lesser amount. Improperly manufactured or mutilated ATPs shall be surrendered to the CWA.

(g) The CWA shall offer to place a household in an alternate issuance system after the first report of nonreceipt, or when circumstances exist that indicate that the household may not receive its benefits through the normal issuance system, such as when a household has a history of reported nonreceipt of ATPs. After two requests for replacement of original or replacement ATPs reported as nondelivered in a six-month period, the CWA shall issue benefits to that household under an alternate issuance system. The two requests may be for either an original or a replacement ATP. The CWA shall keep the household on the alternate issuance system for the length of time the CWA determines to be necessary. The CWA may return the household to the regular issuance system if the CWA finds that the circumstances leading to the loss have changed and the risk of loss has lessened. The placement of a household on an alternate issuance system and the length of time the household is on this system is not subject to the fair hearing process.

(h) Provisions concerning the documentation and reconciliation of replacement issuances are as follows:

1. The CWA shall document in the household's case file each request for replacement, the date, the reason, and whether or not the replacement was provided. This information may be recorded exclusively on the household statement required in (c) above.

2. The CWA shall maintain, in readily-identifiable form, a record of the replacements granted to the household, the reason, the month, and whether the replacement was countable as defined in (b)2iv above. The record may be a case action sheet maintained in the case

## CORRECTIONS

file, notations on the master issuance file, if readily accessible, or a document maintained solely for this purpose. At a minimum, the system shall be able to identify and differentiate among:

- i. ATPs or coupons not received in, or stolen from, the mail, and ATPs stolen after receipt; and
- ii. Replacement issuances which are not subject to a replacement limit.

3. Upon completion of reconciliation in a system utilizing ATPs, the CWA shall update the record required in (h)2 above to indicate whether both the original and replacement ATPs were transacted. If both were not transacted, the record shall clearly indicate that the replacement ATP was not a countable replacement.

4. When a request for replacement is made late in an issuance month, the replacement will be issued in a month subsequent to the month in which the original ATP was issued. All replacements shall be posted and reconciled to the month of issuance of the replacement and may be posted to the month of issuance of the original ATP, so that all duplicate transactions may be identified.

(i) The CWA shall take the following further actions on replacement issuances:

1. On at least a monthly basis, the CWA shall report to the appropriate office of the Postal Inspection Service all ATPs reported as stolen or lost in the mail. The CWA shall assist the Postal Service during any investigation thereof and shall, upon request, supply the Postal Service with facsimiles of the original ATP, if transacted, and the replacement ATP and a copy of the nonreceipt statement. The CWA shall advise the Postal Service if the original ATP is not transacted.

2. When a duplicate replacement ATP is transacted, the CWA shall, at a minimum:

- i. Compare the handwriting on the ATPs to documents contained in the household's case file, including the nonreceipt statement;
- ii. Establish a claim in accordance with N.J.A.C. 10:87-11 where it appears that the household has transacted or caused both ATPs to be transacted; and
- iii. Refer the matter to the CWA's investigation unit, where indicated.

## CORRECTIONS

(a)

### THE COMMISSIONER

#### Social Services

#### Recreation and Leisure Time Activities

#### Adopted New Rules: N.J.A.C. 10A:17-8

Proposed: March 20, 1989 at 21 N.J.R. 665(a).

Adopted: August 8, 1989 by William H. Fauver, Commissioner, Department of Corrections.

Filed: August 14, 1989 as R.1989 d.470, with substantive and technical changes not requiring additional public notice and comment (see N.J.A.C. 1:30-4.3).

Authority: N.J.S.A. 30:1B-6 and 30:1B-10.

Effective Date: September 5, 1989.

Expiration Date: December 15, 1991.

#### Summary of Public Comments and Agency Responses:

The New Jersey Department of Corrections received 10 comments on the proposed new rules. A summary of the comments and the responses of the Department of Corrections are addressed below.

COMMENT: A commenter observed that the educational requirements stated in the proposed new rules were not consistent with the educational requirements that have been established by the New Jersey Department of Personnel for the position of Supervisor of Recreation.

RESPONSE: The Department of Corrections agrees that the Department of Personnel has established the qualifications that a candidate for the position of Supervisor of Recreation must meet. N.J.A.C. 10A:17-8.1(a) will be changed to require the staff member, designated by the Superintendent to direct and supervise the Recreation and Leisure

Time Activities Program, to meet the qualifications that have been established by the Department of Personnel for the position of Supervisor of Recreation.

COMMENT: A commenter suggested that the staff person designated by the Superintendent to direct and supervise the Recreation and Leisure Time Activities Program be required to have at least three years experience in an institution, public school or community recreation program.

RESPONSE: The New Jersey Department of Personnel has established the qualifications that a candidate for the position of Supervisor of Recreation must meet. N.J.A.C. 10A:17-8.1(a) will be changed to require the staff member, designated by the Superintendent to direct and supervise the Recreation and Leisure Time Activities Program, to meet the qualifications that have been established by the Department of Personnel for the position of Supervisor of Recreation.

COMMENT: A commenter suggested that language be added to N.J.A.C. 10A:17-8.4 concerning a close circuit television system to deter the disassembling of television sets by inmates.

RESPONSE: The Department of Corrections believes that language, rules or regulations related to a close circuit television system should be included within Standard Operating Procedure Manuals within an institution.

COMMENT: A commenter indicated that some hobby materials approved by the Superintendent may not be available in the canteen of a correctional facility and that procedures are necessary to permit the purchase of these materials from outside sources.

RESPONSE: The Department of Corrections agrees that some hobby materials may not be available at the canteen and that procedures may be necessary to purchase these materials from outside sources. Proposed new N.J.A.C. 10A:17-8.9(c) does not prohibit the purchase of hobby materials from outside sources. The Department believes that in cases when there is a need to purchase hobby materials from outside sources, the procedures governing these purchases should be developed at the correctional facility upon approval by the Superintendent.

COMMENT: A commenter suggested that a cross reference to N.J.A.C. 10A:18-4.9 be added to proposed new N.J.A.C. 10A:17-8.11(c).

RESPONSE: The Department of Corrections agrees and the cross reference to N.J.A.C. 10A:18-4.9 will be added to the proposed new rule.

COMMENT: A commenter suggested that reference to N.J.A.C. 10A:13, Inmate Work Programs, in proposed new N.J.A.C. 10A:17-8.2(e) be deleted and replaced with reference to Department of Corrections' Standard 620, Inmate Wages.

RESPONSE: The Department of Corrections agrees that reference to N.J.A.C. 10A:13, Inmate Work Programs, should be deleted because this chapter has not been proposed and adopted in the New Jersey Administrative Code yet. The proposed new rule will be amended to delete reference to N.J.A.C. 10A:13 and to state . . . "he or she shall be paid as an inmate recreation aide or paraprofessional."

COMMENT: A commenter suggested that the language, in proposed new N.J.A.C. 10A:17-8.9(a), "An organized arts and crafts program may be provided . . ." be changed to "An organized arts and crafts program shall be provided. . . ."

RESPONSE: The language "An organized arts and crafts program may be provided, when available, under the direction of an assigned instructor on a regular basis" was used because the financial resources available to correctional facilities within the Department of Corrections are limited to such an extent that it is not possible for all correctional facilities to establish such a program with a regularly assigned instructor. The intent of the proposed new rule is to encourage correctional facilities to establish and maintain an arts and crafts program to the extent of the availability of financial resources for that purpose.

COMMENT: A commenter suggested that the language in proposed new N.J.A.C. 10A:17-8.10(c), "Inmate vocal groups, instrumental groups and soloists may perform . . .", and proposed new N.J.A.C. 10A:17-8.10(d), "Appearances of guest artists may be arranged . . ." be changed to use the word "shall" instead of "may" in both instances.

RESPONSE: The word "may" was used in the above mentioned proposed new rules in recognition of the fact that some correctional facilities within the Department of Corrections, for various reasons, do not have a music program or inmates performing in vocal groups, instrumental groups or as soloists for the entertainment of the inmate general population. Consideration has also been given to the fact that it is sometimes difficult to arrange for the appearance of guest artists at a correctional facility. The intent of the proposed new rules is to encourage correctional facilities to implement these programs to the extent of their capability.

COMMENT: A commenter suggested that the language in N.J.A.C. 10A:17-8.3(e), requiring each institution to provide sufficient indoor and outdoor recreation areas for inmates in Administrative Segregation, be changed because the Southern State Correctional Facility is not equipped to offer indoor recreation to inmates in Administrative Segregation.

RESPONSE: When the limitations of the physical plant of an institution are such that an indoor recreation area cannot be provided for inmates in Administrative Segregation, a request for a rule exemption should be submitted to the Commissioner of the Department of Corrections in accordance with the procedures outlined in N.J.A.C. 10A:1-2.7.

COMMENT: A commenter suggested that N.J.A.C. 10A:17-8.15(a), which does not permit inmates assigned to institutions within the Division of Adult Institutions to participate in any community-based trip, be changed to permit an inmate to participate in a community entertainment trip if he or she has attained the appropriate custody status and if adequate supervision is provided.

RESPONSE: The Department cannot make the change requested. The Department must limit the participation of inmates in community-based trips to the extent stated in the proposed new rule in order to protect the public and provide sufficient supervision and security to maintain custody and prevent escapes.

Full text of the adoption follows (additions to proposal indicated in boldface with asterisks \*thus\*; deletions to proposal indicated in brackets with asterisks \*[thus]\*).

## SUBCHAPTER 8. RECREATION AND LEISURE TIME ACTIVITIES

### 10A:17-8.1 Staff assigned to Recreation and Leisure Time Activities Program

(a) The Superintendent shall designate a staff person who shall be responsible for the direction and supervision of the Recreation and Leisure Time Activities Program of the institution, and this staff person must meet the \*[following]\* requirements\*[\*] \*established by the New Jersey Department of Personnel for the position of Supervisor of Recreation.\*

\*[1. Be a graduate of an accredited college with a bachelor's degree in the field of physical education, recreation therapy, or related sports/recreation fields; and

2. Have at least one year of experience in an institutional, public school or community recreation program.]\*

(b) Volunteers may be used to assist the recreation staff in designated Recreation and Leisure Time Program activities (see N.J.A.C. 10A:17-2, Volunteer Service Program).

### 10A:17-8.2 Inmate recreation aides or paraprofessionals

(a) Inmates may be assigned to the Recreation and Leisure Time Activities Program to serve as inmate recreation aides or paraprofessionals.

(b) Inmate recreation aides or paraprofessionals may be utilized as:

1. Scorekeepers;
2. Demonstrators;
3. Projectionists;
4. Referees;
5. Officials;
6. Equipment managers;
7. Clerks;
8. Arts and craft aides; and/or
9. Aides in other recreational related tasks.

(c) Inmate recreation aides or paraprofessionals shall be trained by the recreation staff and receive close supervision from a staff member.

(d) Inmate paraprofessionals under the jurisdiction of the Division of Adult Institutions who are assigned to work in a juvenile correctional facility may accompany athletic teams to athletic activities held at high schools or other correctional facilities if approved by the Deputy Commissioner. Inmate paraprofessionals shall not be permitted to participate in any other type of community based trip (see N.J.A.C. 10A:17-8.15).

(e) In instances when inmate participation in the Recreation and Leisure Time Activities Program constitutes a regular work assignment, \*[the inmate recreation aide or paraprofessional]\* \*he or she\*

## ADOPTIONS

shall be paid \*[in accordance with N.J.A.C. 10A:13, Inmate Work Programs]\* **\*as an inmate recreation aide or paraprofessional\***.

### 10A:17-8.3 Physical facilities utilized by the Recreation and Leisure Time Activities Program

(a) Each institution shall provide the following for the inmate general population:

1. An auditorium or a large area for the assemblage of inmates; and
2. A gymnasium of sufficient size to accommodate athletic activities.

(b) The gymnasium shall contain standard facilities and equipment for a wide variety of activities which may include:

1. Ping-pong;
2. Basketball;
3. Racquetball;
4. Volleyball;
5. Tumbling;
6. Weight lifting;
7. Gymnastics;
8. Rubber horseshoes and quoits;
9. Handball;
10. Boxing; and
11. Dance.

(c) The auditorium should contain a stage, screen and enough seats to accommodate, at one time, at least one half of the inmate population eligible to attend activities scheduled in this area. The stage facilities shall include:

1. A sound system;
2. Curtains;
3. A lighting system; and
4. Other equipment necessary for multipurpose use.

(d) The outdoor recreation area shall contain standard facilities and equipment for a wide variety of activities which may include:

1. Baseball;
2. Football;
3. Softball;
4. Soccer;
5. Basketball;
6. Volleyball;
7. Handball;
8. Weight lifting;
9. Horseshoes; and
10. Track and field events.

(e) Each institution shall provide sufficient indoor and outdoor recreation areas for inmates in Administrative Segregation and other specialized housing units, in accordance with N.J.A.C. 10A:5, Close Custody Units.

(f) Each institution shall establish policies and procedures for the provision of recreation and leisure time activities to inmates assigned to the satellite unit(s) under the jurisdiction of the institution.

### 10A:17-8.4 Recreational equipment

(a) Regulation recreational equipment shall be used for all athletic activities when improvised equipment would prove hazardous.

(b) Inmates shall be instructed in the proper use and care of recreational equipment.

(c) Each institution, except the New Jersey State Prison, shall provide adequate facilities for television viewing, by each inmate, a minimum of twice per week. Television viewing at the New Jersey State Prison shall be provided equitably to inmates a minimum of once per week on a rotational basis.

(d) Except at the New Jersey State Prison and the East Jersey State Prison, each housing unit shall be supplied with a television set and sufficient quiet games. At the New Jersey State Prison and the East Jersey State Prison, one or more indoor areas shall be equipped with television sets for the use of inmates.

(e) Inmates shall be permitted to have personal electronic devices, such as record players, records, radios and television sets, subject to restrictions established by the correctional facility based upon the following factors:

1. The maintenance of security;
2. The suppression of unnecessary noise;

## CORRECTIONS

3. The availability of space;

4. The capability of the electrical system; or

5. Other factors related to the orderly operation of the institution.

(f) Each institution and its satellite unit(s) shall utilize sound movie projectors or VHF recorders of appropriate size to accommodate classroom or general inmate entertainment use.

### 10A:17-8.5 Recreation and leisure time needs assessment

As a part of the orientation process, each institution shall complete an assessment of the recreation and leisure interests and skills of newly admitted inmates, and provide the inmates with information related to the recreation and leisure time activities that are available at the institution.

### 10A:17-8.6 Scheduling active and quiet recreation

(a) Planned recreation program activities shall be scheduled year round, and athletic activities shall be scheduled according to the season.

(b) Active recreation shall include all phases of organized or unorganized athletics, dance, aerobics or other recreational activities.

(c) Inmates shall be given the opportunity to participate in a minimum of one hour of active recreation per day.

(d) Inmates shall also be given the opportunity to participate in a minimum of one hour of quiet recreation per day. Inmates may watch television, read, play quiet games, participate in some organized club, or work in arts and crafts.

(e) When weather permits, appropriate quiet activities may be moved to an outdoor area.

(f) When all scheduled activities and other assignments are completed, inmates shall be permitted to do hobby work in their cells, dormitories, cottages or other locations in the institution unless such activity interferes with the maintenance of security or the orderly operation of the institution.

(g) Recreation for inmates in Close Custody Units shall be provided in accordance with N.J.A.C. 10A:5, Close Custody Units.

### 10A:17-8.7 Instruction in athletic and other recreation skills

In order to encourage inmates to participate in a variety of recreational activities, instruction in the rules and skills required for participation shall be provided, when appropriate.

### 10A:17-8.8 Showers

The opportunity to shower shall be available to inmates after participating in an active recreation program, unless such activity interferes with the maintenance of security or the orderly operation of the institution.

### 10A:17-8.9 Arts and crafts program

(a) An organized arts and crafts program may be provided, when available, under the direction of an assigned instructor on a regular basis.

(b) Inmates may participate in arts and crafts activities in classrooms, cells, dormitories, cottages or other locations in the institution, unless such activity interferes with the maintenance of security or the orderly operation of the institution.

(c) Hobby kits and materials for arts and crafts, that have been approved by the Superintendent, may be purchased at the canteen.

(d) Inmates shall not engage in stamp collecting as a hobby.

### 10A:17-8.10 Music

(a) The music program, when available, shall be directed by a qualified music instructor who shall adapt the music program to the needs of the inmates.

(b) A separate practice area, with sufficient storage space is desirable for the music program, so long as sufficient room is available.

(c) Inmate vocal groups, instrumental groups and soloists may perform for the inmate general population and for groups who visit the institution.

(d) Appearances of guest artists may be arranged, when appropriate.

### 10A:17-8.11 Publications

(a) Appropriate institutional publications, such as newsletters and pamphlets, written by inmates shall be encouraged.

(b) A staff member shall be assigned to supervise the content and production of publications.

(c) Articles and materials that are written by inmates shall be reviewed for content by the Superintendent or his or her designee and approved or disapproved prior to publication \*(see N.J.A.C. 10A:18-4.9)\*.

#### 10A:17-8.12 Motion pictures

Full length sound motion pictures or VCR cassettes for general entertainment shall be available to inmates in the general population a minimum of once per week, except when such general entertainment interferes with the maintenance of security or the orderly operation of the institution.

#### 10A:17-8.13 Clubs and special interest groups

(a) Clubs shall be formed for inmates interested in specific games such as chess and bridge.

(b) Groups shall be formed for inmates who are interested in current events, book discussions and other interests.

(c) All clubs and groups shall be supervised by staff members.

#### 10A:17-8.14 Inside entertainment

(a) Entertainment, such as variety shows and choral groups, may be brought into the institution from the outside community on a regular basis, at the discretion of the Superintendent.

(b) Inmates may be permitted to utilize their talents by participating in dramatic skits, variety shows and other similar activities.

#### 10A:17-8.15 Community entertainment

(a) Inmates assigned to institutions within the Division of Adult Institutions shall not be permitted to participate in any community based trip.

(b) Inmate paraprofessionals under the jurisdiction of the Division of Adult Institutions, who are assigned to work in a juvenile correctional facility, shall not be permitted to participate in any community based trip, except the paraprofessionals that have been approved by the Deputy Commissioner to accompany athletic teams to athletic activities held by high schools or other correctional facilities.

(c) Juvenile inmates may be permitted to participate in recreation and leisure time activities in the community if their custody status and Department of Corrections policies and procedures permit the juveniles to leave the institution.

#### 10A:17-8.16 Staff reference area on recreation

(a) Each institution shall subscribe to several recreation and physical education journals and newsletters.

(b) Each institution shall provide a reference area where current books on recreation and physical education shall be available for use by recreation staff members.

#### 10A:17-8.17 Budget requests

The staff person responsible for the Recreation and Leisure Time Activities Program shall submit an annual budget request to the Superintendent or his or her designee which specifies the resources necessary to purchase materials, equipment and supplies to conduct the Recreation and Leisure Time Activities Program.

#### 10A:17-8.18 Report of major recreation and leisure time activities

At the end of each month, the staff person responsible for the Recreation and Leisure Time Activities Program shall submit a report to the Superintendent or his or her designee which indicates all major recreation and leisure time activities conducted that month and the number of inmates who participated in each activity.

## INSURANCE

### (a)

#### OFFICE OF THE COMMISSIONER

#### New Jersey Insurance Development Fund FAIR Plan Surcharge

#### Adopted Amendment: N.J.A.C. 11:1-5.1

Proposed: July 3, 1989 at 21 N.J.R. 1816(a).

Adopted: August 11, 1989 by Kenneth D. Merin, Commissioner, Department of Insurance.

Filed: August 14, 1989 as R.1989 d.478, **without change.**

Authority: N.J.S.A. 17:1C-6(e) and 17:37A-18 through 21.

Effective Date: September 5, 1989.

Expiration Date: February 3, 1991.

#### Summary of Public Comments and Agency Responses:

**No comments received.**

**Full text** of the adoption follows.

#### 11:1-5.1 FAIR Plan Surcharge

(a) On August 3, 1988, the Commissioner of Insurance ascertained and determined that the net value of the New Jersey Insurance Development Fund, as of December 31, 1987, was more than five percent of the premiums written on basic property insurance in New Jersey in calendar year 1987. Accordingly, no further surcharge on said premiums and no further payments to said Fund shall be made.

(b) Application of surcharge when imposed by the Commissioner of Insurance shall be as follows:

1. A surcharge shall be imposed in an amount prescribed in an order of the Commissioner of Insurance on premiums of the following policies and endorsements effective on or after the date fixed by the Commissioner in his or her order.

i.-iv. (No change.)

2. The surcharge, if deemed necessary by the Commissioner of Insurance, shall apply to all new and renewal policies effective on or after the date fixed by the Commissioner in his or her order and to the additional premiums on all endorsements effective on or after that date.

3. Policies written for a term longer than one year with an effective date on or after the date fixed by the Commissioner in his or her order shall be charged, if deemed necessary by the Commissioner of Insurance, in accordance with this section.

4. Return of the surcharge, if any is charged by order of the Commissioner of Insurance, is permitted on policy activity such as endorsement decreasing premium and cancellations effective the date fixed by the Commissioner in his or her order.

5. For policies with an effective date on or after the date fixed by the Commissioner in his or her order, which are subject to audit, the surcharge, if any is charged by order of the Commissioner of Insurance, shall be based on the audited premium.

6. The surcharge, if deemed necessary by the Commissioner of Insurance, shall be charged in full. Rounding to the nearest whole dollar is not permitted.

7. If a surcharge is deemed necessary by the Commissioner of Insurance, commissions and premium taxes shall not be payable thereon, and the insurer is prohibited from absorbing such surcharge as an inducement for insurance or for any other reason.

(c) If a surcharge is deemed necessary by the Commissioner of Insurance, the surcharge shall be collected by each insurer and paid over to the State Treasurer of New Jersey, not later than March 1 and September 1 of each year.

(d) The method of billing shall be as follows:

1. If a surcharge is deemed necessary by the Commissioner of Insurance, the surcharge shall be a separate charge to the insured in addition to the premium to be paid and shall be shown separately or combined with the Guaranty Association charge.

2. If a surcharge is deemed necessary by the Commissioner of Insurance, when the surcharge is combined with the Guaranty As-

sociation charge, it shall be identified as "Surcharges," and when it is shown separately, it shall be identified as "Surcharge."

## LABOR

### (a)

#### BOARD OF REVIEW

##### Board of Review Rules

##### Readoption with Amendments: N.J.A.C. 12:20

Proposed: June 5, 1989 at 21 N.J.R. 1496(a).

Adopted: August 14, 1989 by Charles Serraino, Commissioner, Department of Labor.

Filed: August 14, 1989 as R.1989 d.473, **without change**.

Authority: N.J.S.A. 34:1-20, 34:1A-3(e), 43:21-6(d) and (e), 43:21-10 and 43:21-17.

Effective Date: August 14, 1989, Readoption; September 5, 1989, Amendments.

Expiration Date: August 14, 1994.

##### Summary of Public Comments and Agency Responses:

The Department received one public comment concerning the proposal. The commenter, a legal services corporation, objected to the amendment to N.J.A.C. 12:20-5.4(a) which permits nonattorneys to represent clients before the board of review or appeal tribunal. The commenter argued that such a practice would constitute an unauthorized practice of law.

The amendment to N.J.A.C. 12:20-5.4(a) was necessary to implement N.J.A.C. 43:21-17(b) which permits nonattorneys to represent clients before the board of review or appeal tribunal. The Department must follow the requirements of the statute. Thus, the amendment remains as proposed.

**Full text** of the readoption appears in the New Jersey Administrative Code at N.J.A.C. 12:20-1 through 5.

**Full text** of the amendments to the readoption follows.

##### 12:20-1.1 Membership

The Board of Review shall consist of three members appointed by the Director subject to the provisions of N.J.S.A. Title 11A, and the supplements and amendments thereto, from Department of Personnel eligible lists.

##### 12:20-1.3 Duties

(a)-(c) (No change.)

(d) The executive secretary of the Board of Review shall keep a record of proceedings at meetings of the Board of Review and shall prepare minutes to record all actions of the Board at each meeting. Said minutes shall be presented to the Board of Review for approval at its next meeting.

(e) The executive secretary may, with the consent of the Board of Review, issue subpoenas and shall sign all orders and other official documents issued in the name of the Board of Review and shall certify its decisions. The executive secretary shall maintain the permanent file of the approved minutes of Board of Review meetings and shall be charged with the supervision of all administrative work of the Board of Review.

##### 12:20-2.1 Membership

Appeal tribunals shall consist of a single member who shall be a salaried examiner appointed by the Director subject to the provisions of N.J.S.A. Title 11A, and the supplements and amendments thereto, from Department of Personnel lists.

##### 12:20-2.2 Duties

It shall be the duty of the appeal tribunals to hear and decide disputed benefit claims, including appeals from determinations with respect to demands for refunds of benefits under N.J.S.A. 42:21-16(d) of the Unemployment Compensation Law of New Jersey.

##### 12:20-2.3 Disqualification of members of appeal tribunals

(a) (No change.)

(b) Challenges to the interest of any member of an appeal tribunal may be heard and decided by the chief appeals examiner of the appeal tribunal, or, in his or her discretion, referred to the Board of Review.

##### 12:20-3.1 Presentation of appealed claims

(a) Any written statement, filed within the time for appeal allowed by law, which sets forth the fact that a party to a determination made by the Division of Employment Security is aggrieved thereby or dissatisfied therewith shall be deemed to be an appeal.

(b) Every appeal shall set forth the reasons alleged for disputing the determination or decision appealed from. The appellant shall not be required to use technical forms or language in setting forth the said reasons.

(c) In computing any period of time the day of the act or event after which the designated period begins to run is not to be included. The last day of the period so computed is to be included, unless it is a Saturday, Sunday or legal holiday, in which event the period runs until the end of the next day which is neither a Saturday, Sunday nor a legal holiday.

(d) (No change in text.)

(e) In cases involving a large number of claimants, a blanket notice of appeal may be filed on behalf of, or with respect to, such claimants, listing their full names and social security numbers, and the date of filing of such notice will be accepted as the date of filing of the individual appeals thereunder, provided, however, no case will be scheduled for hearing until an individual appeal on the prescribed appeal form has been filed with the appeal tribunal. Following the filing of the blanket appeal, a reasonable time will be allowed for preparation of the individual appeals.

(f) (No change in text.)

(g) Notice of appeal filed in the local office shall be transmitted immediately to the appeal tribunal. If, after an appeal has been filed, it is found that the matter may be adjusted to the satisfaction of the parties without further hearing, a request for dismissal of the appeal will be entertained and acted upon by the tribunal to which the case is referred.

##### 12:20-3.2 Conduct of hearings

(a) The proceedings shall be fair and impartial and shall be conducted in such manner as may be best suited to determine the claimant's benefit rights. Hearings shall, in the absence of a showing of sufficient cause for a closed hearing, be open to the public. The examiner shall open the hearing by ascertaining and summarizing the issue or issues involved in the appeal. The parties, their attorneys or representatives may examine or cross-examine witnesses, inspect documents, and explain or rebut any evidence. An opportunity to present argument shall be afforded the parties, which argument shall be made part of the record. Where a party is not represented, the tribunal shall give every assistance that does not interfere with the impartial discharge of its official duties. The tribunal may examine each party or witness to such extent as it deems necessary. All oral testimony shall be under oath or affirmation and shall be recorded.

(b)-(c) (No change.)

##### 12:20-3.3 Adjournment of hearing

(a) The appeal tribunal shall use their best judgment as to when adjournments of hearings shall be granted in order to secure all facts that are necessary and to be fair to the parties.

(b) (No change.)

##### 12:20-3.4 Decisions of appeal tribunals

(a) Copies of all decisions and the reasons therefor shall be mailed to the claimant and to all other parties to the appeal and shall be accompanied by a notice specifying the appeal rights of the parties. The notice of appeal rights shall state clearly the place and manner for taking an appeal from the decision and the period within which an appeal may be taken.

(b) The decision shall be in the following form:

1. The first section shall indicate the party appealing, the determination appealed, the date of the decision, and the date of the initiation of the appeal. The appearances shall be noted.

2.-3. (No change.)

4. The fourth section shall contain the "Decision." This shall be followed by the signature of the examiner. Each decision shall also indicate the dates of hearing and mailing.

(c) Every decision of an appeal tribunal shall, immediately upon issuance, be transmitted to the Executive Secretary of the Board of Review, who shall present it to the Board of Review for consideration. The Board shall forthwith determine whether or not the decision shall be allowed to stand. The Board may, by majority vote, set aside any decision of an appeal tribunal and may either remand the case to the same or another appeal tribunal for new hearing and decision or withdraw the case to itself. A case so withdrawn may be decided by the Board on the basis of the appeal tribunal record or may be remanded to the same or another appeal tribunal for the taking of evidence upon which the Board may act. The Board of Review may also, if it so desires, hold a new hearing itself in any such case.

(d) Whenever an appeal is scheduled for a hearing before an appeals examiner and such appeal results in an order of dismissal for nonappearance of the appellant, the chief appeals examiner shall, upon application made by such appellant, within six months after the making of such order or dismissal, and for good cause shown, set aside the order of dismissal and shall reschedule such cause of hearing in the usual manner.

#### 12:20-4.3 Presentation of appeals

(a)-(g) (No change.)

(h) Any party, including the appellant whose appeal resulted in any affirmation of the appeal tribunal decision on the record may by the appeal tribunal, may apply for reopening of the Board's decision. If such application is granted all parties will be notified if a new hearing is scheduled.

#### 12:20-4.5 Hearing appeals on own motion

(a) Within the legal time limit for appeal following a decision by an appeal tribunal and in the absence of the filing by any of the parties to the decision of the appeal tribunal of a notice of appeal, the Board of Review, on its own motion, may withdraw such decision to itself and may either decide the case on the record below or may remand the decision to the appeal tribunal or may schedule a hearing before the Board of Review or order the parties to appear before it for a hearing on the claim or any issue involved therein.

(b) (No change.)

#### 12:20-5.1 Issuance of subpoenas

Subpoenas to compel the attendance of witnesses and the production of records for any hearing on an appeal may be directed to be issued by a member of the Board of Review in cases appealed to the Board of Review, or by the appeal tribunal, in cases appealed to an appeal tribunal, only upon the showing of the necessity therefor by the party applying for the issuance for such subpoena.

#### 12:20-5.4 Representation

(a) In any proceeding before an appeal tribunal or before the Board of Review, the claimant or employer may appear pro se or employ an attorney or a nonattorney to represent him.

(b) In any proceeding on an appeal before an appeal tribunal or the Board of Review, all fees for persons representing claimants shall be approved by the Board of Review.

(c) The amount of fees awarded to counsel shall be discretionary with the Board of Review.

(d) The Board of Review or any appeal tribunal, in its discretion, may refuse to allow to appear before it any person who misconducts himself at a hearing or who intentionally or repeatedly fails to observe the provisions of the Unemployment Compensation Law of New Jersey, the rules and regulations of the division, or the rules of the Board of Review.

(a)

## DIVISION OF UNEMPLOYMENT AND TEMPORARY DISABILITY INSURANCE

### Board of Review and Appeal Tribunal Telephone Hearing Procedures

#### Adopted New Rules: N.J.A.C. 12:20-6

Proposed: June 19, 1989 at 21 N.J.R. 1644(a).

Adopted: August 14, 1989 by Charles Serraino, Commissioner, Department of Labor.

Filed: August 14, 1989 as R.1989 d.474, with technical changes not requiring additional public notice and comment (see N.J.A.C. 1:30-4.3).

Authority: N.J.S.A. 34:1-20, 34:1A-3(e), 43:21-6(d) and (e), 43:21-10.

Effective Date: September 5, 1989.

Expiration Date: August 14, 1994.

#### Summary of Public Comments and Agency Responses:

The Department did not receive any public comments on the proposed new rules.

The Department has made one minor editorial change to N.J.A.C. 12:20-6.5(b). The "Board of Tribunal" has been corrected to read "Board or Tribunal".

Full text of the adoption follows (additions indicated in boldface with asterisks \*thus\*; deletions indicated in brackets with asterisks \*[thus]\*).

## SUBCHAPTER 6. TELEPHONE HEARINGS

### 12:20-6.1 Purpose and scope

(a) The purpose of this subchapter is to set the procedures for appeal hearings by telephone.

(b) The procedures in this subchapter apply to appeals to the Board and Tribunal.

### 12:20-6.2 Definitions

The following words and terms, when used in this subchapter, shall have the following meanings unless the context clearly indicates otherwise.

"Board" means Board of Review established under N.J.S.A. 43:21-10(d).

"Hearing" means any in-person hearing or any telephone hearing before the Board or the Tribunal.

"Telephone hearing" means a hearing at which all parties, witnesses, representatives and attorneys appear via telephone.

"Tribunal" means Appeal Tribunal established under N.J.S.A. 43:21-6(d).

### 12:20-6.3 Authorization of telephone hearings

(a) A telephone hearing may be conducted at the initiation of the Board or the Tribunal or upon the request of any party with the consent of the Board or Tribunal. Telephone hearings shall be subject to the general rules governing hearings and appeals in N.J.A.C. 12:20-3 and 12:20-4 as well as the rules governing telephone hearings.

### 12:20-6.4 Telephone hearings scheduled by the Board or Tribunal

(a) The Board or Tribunal, in its discretion, may initiate or schedule a telephone hearing:

1. When it appears from the record that a party or necessary witness is located more than 50 miles from the location from which the Board or Tribunal will conduct the hearing; or

2. When a party or witness cannot appear in person because of a physical, medical or other compelling reason.

### 12:20-6.5 Telephone hearings requested by a party

(a) Any party to an appeal may request a telephone hearing by submitting, in writing, the reasons for the request to the Board or Tribunal no less than three days before the scheduled in-person hearing.

(b) The Board \*[of]\* \*or\* Tribunal shall exercise its discretion in granting or denying such requests and immediately notify the parties of its decision.

#### 12:20-6.6 Objections to a telephone hearing

(a) Any party may object to a telephone hearing. Objections shall:

1. Be in writing and received by the Board or Tribunal at least two days before the scheduled telephone hearing; and
2. Set forth the reasons supporting the objections.

(b) The hearing officer may reject a party's objection to a telephone hearing if the hearing officer determines any of the following:

1. That the objecting party's intent is to purposely inconvenience the other party or delay the proceeding;
2. That a party or witness is more than 50 miles away; or
3. That a person is unable to appear in person because of physical, medical or other compelling reason.

(c) If the hearing officer accepts a party's objections to a telephone hearing, the hearing shall be held at a location to be determined by the hearing officer.

#### 12:20-6.7 Telephone hearing notice and documentation

(a) The notice of telephone hearing shall contain the following:

1. That the parties have a right to object to a telephone hearing;
2. The circumstances under which the telephone hearing will be conducted; and
3. Written instructions as to how the telephone hearing will be conducted.

(b) Any party that intends to offer documentary or physical evidence at the telephone hearing shall submit a copy of that evidence to the Board or Tribunal at least five days prior to the hearing.

1. Any evidence not submitted as required in this subsection may be admitted only with the consent of all parties.

(c) When scheduling a telephone hearing, the Board or Tribunal shall enclose with the hearing notice copies of all documents that are to be offered into evidence.

#### 12:20-6.8 Conduct of telephone hearings

(a) The Board or Tribunal, at the inception of the hearing, shall advise all participants that the proceedings are being recorded.

(b) Any party who fails to appear at the scheduled telephone hearing shall meet the requirements of N.J.A.C. 12:20-3 or 12:20-4 before any reopening of the hearing shall be granted.

(c) The Board or Tribunal shall permit any party a reasonable opportunity to question any witness testifying via telephone for the purpose of verifying the identity of such witness.

### (a)

## DIVISION OF EMPLOYMENT AND TRAINING

### Job Training Partnership Act and New Jersey Jobs Training Act Non-Criminal Complaint/Grievance, Hearing and Review Procedures at the Employer, SDA, State and Federal Level

#### Adopted Amendments: N.J.A.C. 12:41

Proposed: June 5, 1989 at 21 N.J.R. 1498(a).

Adopted: August 14, 1989 by Charles Serraino, Commissioner, Department of Labor.

Filed: August 14, 1989 as R.1989 d.475, with technical changes not requiring additional public notice and comment (see N.J.A.C. 1:30-4.3).

Authority: N.J.S.A. 34:1-20, 34:1A-3(e), 29 U.S.C.A. §1554, 20 CFR §629.51 et seq., and N.J.S.A. 34:15B-26.

Effective Date: September 5, 1989.

Expiration Date: January 17, 1994.

Summary of Public Comments and Agency Responses:

The Department did not receive any public comments on the proposed amendments.

The Department has made a minor editorial change to N.J.A.C. 12:41-1.6(b)7xii. The phrase "and/or NJJTA" has been deleted from the last clause because Federal review is not appropriate for complaints under NJJTA.

Full text of the adoption follows (additions indicated in boldface with asterisks \*thus\*; deletions indicated in brackets with asterisks \*[thus]\*).

## CHAPTER 41

### DIVISION OF EMPLOYMENT AND TRAINING

#### SUBCHAPTER 1. JOB TRAINING PARTNERSHIP ACT (JTPA) AND NEW JERSEY JOBS TRAINING ACT (NJJTA): NON-CRIMINAL COMPLAINT/GRIEVANCE, HEARING AND REVIEW PROCEDURES AT EMPLOYER, SDA, STATE AND FEDERAL LEVEL

##### 12:41-1.1 Purpose

(a) The purpose of this subchapter is to set forth the grievance, hearing and review procedures required under the Job Training Partnership Act (JTPA) at 29 U.S.C.A. §1554 and the regulations that implement the JTPA at 20 CFR §629.51 et seq.

(b) This subchapter also sets forth the grievance, hearing and review procedures for the New Jersey Jobs Training Act (NJJTA) as required by the Commissioner pursuant to N.J.S.A. 34:15B-26.

##### 12:41-1.2 Scope

(a) Employers of JTPA and/or NJJTA participants shall follow the grievance and hearing requirements set forth at N.J.A.C. 12:41-1.5. The employer grievance and hearing procedures shall apply to any JTPA and/or NJJTA participant aggrieved by his or her employer.

(b) Each SDA shall follow, at a minimum, the grievance and hearing requirements set forth at N.J.A.C. 12:41-1.6. The SDA grievance and hearing procedures shall apply to the following:

1. JTPA and/or NJJTA participant appeals from decisions at the employer level;
2. JTPA and/or NJJTA participant complaints;
3. Subgrantee complaints (schools; and employers with on-the-job training contracts; and consultants); and
4. Complaints from other interested persons.

(c) The State review procedures set forth at N.J.A.C. 12:41-1.7 shall apply to the following:

1. JTPA and/or NJJTA participant appeals from decisions at the SDA level;
2. Subgrantee appeals from decisions at the SDA level; and
3. Appeals by other interested persons from decisions at the SDA level.

(d)-(f) (No change.)

##### 12:41-1.3 Definitions

The following terms, when used in this subchapter, shall have the following meanings, unless the context clearly indicates otherwise:

"Grantee/contractor/subrecipient" means any person or government department, agency or establishment (private-for-profit/non-profit) that receives Federal JTPA and/or NJJTA funds to carry out JTPA and/or NJJTA programs through a State or local government but does not include an individual who is a beneficiary of such a program.

"NJJTA" means New Jersey Jobs Training Act, N.J.S.A. 34:15B-11 et seq.

"Participant" means any individual who has been determined eligible for participation upon intake, and has started receiving employment, training, or services (except post-termination services) funded under the JTPA and/or NJJTA, following intake. Individuals who receive only outreach and/or intake and assessment services or postprogram followup are excluded.

"SDA grant recipient" means the entity that receives JTPA and/or NJJTA funds for a SDA directly from the State.

...

## 12:41-1.4 (No change.)

## 12:41-1.5 Grievance and hearing procedures at the employer level

(a) Each employer, including private-for-profit employers under the JTPA and/or NJJTA, shall maintain a grievance and hearing procedure relating to the terms and conditions of employment available to its participants.

1. (No change.)

(b) (No change.)

## 12:41-1.6 Grievance and hearing procedures at the SDA level

(a) Each SDA shall establish and maintain grievance and hearing procedures for grievances or complaints about its programs and activities from participants, subgrantees, subcontractors and other interested persons. The procedures shall include the resolution of complaints alleging a violation of the JTPA and/or NJJTA, regulations, grant or other agreements under the JTPA and/or NJJTA.

(b) The grievance and hearing procedures shall contain, at a minimum, the following requirements:

1. Upon enrollment into a JTPA and/or NJJTA program, the SDA shall provide participants with a written description of the grievance procedures which shall include the requirements set forth in (b) 4 through 7 below. The SDA shall also provide subcontractors and subgrantees with these procedures no later than the date of execution of the contract between the SDA and the subcontractor.

2. (No change.)

3. The grievance and hearing procedures shall provide that the identity of any person who has furnished information relating to, or assisting in, an investigation of a possible violation of the JTPA and/or NJJTA shall be kept confidential to the extent possible, consistent with a fair determination of the issues.

4.-6. (No change.)

7. At a minimum, the SDA shall also provide participants and subcontractors with the following:

i.-xi. (No change.)

xii. Written notice that the complainant has a right to request a review by the Secretary for JTPA complaints and by the Commissioner pursuant to the Administrative Procedure Act, N.J.S.A. 52:14B-1 et seq.,\* for NJJTA complaints if the State does not render a decision, and that the Federal review is confined to allegations of violations of law under the JTPA \*[and/or NJJTA]\*; and

xiii. (No change.)

8. (No change.)

## 12:41-1.7 Review procedures at the State level

(a)-(b) (No change.)

(c) Upon filing the request for review, the complainant shall simultaneously submit the following:

1.-4. (No change.)

5. If applicable, citations to the provisions of the JTPA and/or NJJTA or other agreements under the Act believed to have been violated;

6.-7. (No change.)

(d)-(e) (No change.)

(f) If the Director fails to issue a decision at the State level, the complainant or appellant may request a review at the Federal level for JTPA complaints or a hearing pursuant to the Administrative Procedure Act for NJJTA complaints.

## 12:41-1.8 Hearing procedures at the State level

(a)-(e) (No change.)

(f) If the Commissioner fails to issue a written decision within 30 days of the hearing, the complainant or respondent may appeal to the Secretary utilizing the procedures set forth in N.J.A.C. 12:41-1.9 for JTPA complaints. For NJJTA complaints, the complainant may request a hearing pursuant to the Administrative Procedure Act.

(g) (No change.)

## 12:41-1.9 (No change.)

## 12:41-1.10 Protection of complainants

(a) No recipient shall discriminate against or unlawfully deny JTPA and/or NJJTA benefits to any participant or individual con-

nected with the administration of the program who has filed a complaint or instituted or caused to be instituted any proceeding related to the JTPA and/or NJJTA, or has testified or is about to testify in any such proceeding or investigation under or related to the JTPA and/or NJJTA.

(b) The Secretary or Commissioner shall, within 30 days, take such action or order such corrective measures, as necessary, with respect to the recipient or the aggrieved individual, or both.

## (a)

## DIVISION OF WORKPLACE STANDARDS

**Safety and Health Standards for Public Employees  
Hazardous Waste Operations and Emergency  
Response**
**Adopted Amendments: N.J.A.C. 12:100-4.2 and 5.2**

Proposed: June 19, 1989 at 21 N.J.R. 1646(a).

Adopted: August 14, 1989 by Charles Serraino, Commissioner,  
Department of Labor.

Filed: August 14, 1989 as R.1989 d.476, **without change.**

Authority: N.J.S.A. 34:1-20, 34:1A-3(e) and 34:6A-25 et seq.,  
specifically 34:6A-30.

Effective Date: September 5, 1989.

Expiration Date: November 5, 1989.

**Summary of Public Comments and Agency Responses:**

**No comments received.**

**Full text of the adoption follows.**

## 12:100-4.2 Adoption by reference

(a) The standards contained in 29 CFR Part 1910, General Industry Standards with the amendments published in the Federal Register through March 6, 1989 with certain exceptions noted in (b) and (c) below are adopted as occupational safety and health standards and shall include:

1.-19. (No change.)

(b)-(c) (No change.)

## 12:100-5.2 Adoption by reference

(a) The standards contained in 29 CFR Part 1926, Construction Industry Standards with the amendments published in the Federal Register through June 16, 1988, are adopted as occupational safety and health standards and shall include:

1.-14. (No change.)

15. Subpart Q—Concrete and masonry construction;

16.-22. (No change.)

(b)-(c) (No change.)

## (b)

## DIVISION OF WORKPLACE STANDARDS

**Safety and Health Standards for Public Employees  
Work in Confined Spaces**
**Adopted Amendment: N.J.A.C. 12:100-9.2**

Proposed: June 19, 1989 at 21 N.J.R. 1647(a).

Adopted: August 14, 1989 by Charles Serraino, Commissioner,  
Department of Labor.

Filed: August 14, 1989 as R.1989 d.477, **without change.**

Authority: N.J.S.A. 34:1-20, 34:1A-3(e) and 34:6A-25 et seq.,  
specifically 34:6A-30.

Effective Date: September 5, 1989.

Expiration Date: November 5, 1989.

**Summary of Public Comments and Agency Responses:**

**No comments received.**

**Full text of the adoption follows.**

12:100-9.2 Definitions

The following words and terms, when used in this subchapter, shall have the following meanings unless the context clearly indicates otherwise.

"Hazardous atmosphere" means an atmosphere presenting a potential for death, disablement, injury, or acute illness from one or more of the following causes.

1.-3. (No change.)

4. An atmosphere concentration of any toxic or hazardous substance above the permissible exposure limits pursuant to 29 CFR §1910.1000 and N.J.A.C. 12:100-4.2, Air contaminant exposure limits;

5.-6. (No change.)

**LAW AND PUBLIC SAFETY**

**(a)**

**BOARD OF DENTISTRY**

**Resumption of Active Practice by Inactive Dental Hygienists**

**Adopted New Rule: N.J.A.C. 13:30-2.19**

Proposed: June 5, 1989 at 21 N.J.R. 1500(c).

Adopted: July 6, 1989 by the Board of Dentistry, Samuel Furman, D.D.S., President.

Filed: August 7, 1989 as R.1989 d.460, **without change.**

Authority: N.J.S.A. 45:6-3.

Effective Date: September 5, 1989.

Expiration Date: April 15, 1990.

**Summary of Public Comments and Agency Responses:**

Two comments were received in support of the amendment, from the New Jersey Dental Hygienists Association and the New Jersey Dental Association.

Full text of the adoption follows.

13:30-2.19 Resumption of active practice by inactive dental hygienists

(a) The minimum standards which must be met by applicants who have been on the inactive status list for five or more years and who want to resume the practice of dental hygiene are as follows:

1. The individual must apply to the Board for a current biennial certificate of registration and pay the prescribed registration fee.

2. An individual licensed and practicing in another state must furnish the Board with a certification from the other state that the license to practice dental hygiene is in good standing.

3. An individual who has not practiced for five or more years must:

i. Pass the Northeast Regional Board (N.E.R.B.) examination in dental hygiene; or

ii. Complete satisfactorily a Board approved clinical refresher course provided by an institution accredited by the American Dental Association Commission on Dental Accreditation.

4. An individual who has not practiced for more than 10 years must pass the N.E.R.B. examination in dental hygiene.

**(b)**

**BOARD OF PSYCHOLOGICAL EXAMINERS**

**Examination Fees**

**Adopted Amendment: N.J.A.C. 13:42-1.2**

Proposed: June 19, 1989 at 21 N.J.R. 1649(a).

Adopted: July 24, 1989 by the State Board of Psychological Examiners, Stephen Patterson, Ph.D., Chairman.

Filed: August 11, 1989 as R.1989 d.467, **without change.**

Authority: N.J.S.A. 45:14B-13.

Effective Date: September 5, 1989.

Expiration Date: October 31, 1993.

**Summary of Public Comments and Agency Responses:**

**No comments received.**

Full text of the adoption follows.

13:42-1.2 Fees

(a) Charges for examinations, licensure and other services are:

1. (No change.)

2. Examination fee: \$200.00 written, \$75.00 oral

i. Re-examination fee: \$200.00 written, \$75.00 oral

3.-12. (No change.)

(b) (No change.)

**(c)**

**BOARD OF VETERINARY MEDICAL EXAMINERS**

**State Board of Veterinary Medical Examiners Rules**

**Readoption: N.J.A.C. 13:44**

Proposed: June 5, 1989 at 21 N.J.R. 1501(a).

Adopted: July 24, 1989 by the Board of Veterinary Medical Examiners, Jean M. Buist, D.V.M., President.

Filed: August 7, 1989 as R.1989 d.459, **without change.**

Authority: N.J.S.A. 45:16-3.

Effective Date: August 7, 1989.

Expiration Date: August 7, 1994.

**Summary of Public Comments and Agency Responses:**

**No comments received.**

Full text of the readoption may be found in the New Jersey Administrative Code at N.J.A.C. 13:44.

**PUBLIC UTILITIES**

**(d)**

**BOARD OF PUBLIC UTILITIES**

**Telephone**

**Regulation of Alternative Operator Service (AOS) Providers**

**Adopted New Rules: N.J.A.C. 14:10-6**

Proposed: December 19, 1988 at 20 N.J.R. 3115(a).

Adopted: August 4, 1989 by the Board of Public Utilities, Christine Todd Whitman, President.

Filed: August 9, 1989 as R.1989 d.463, with substantive and technical changes not requiring additional public notice and comment (see N.J.A.C. 1:30-4.3).

Authority: N.J.S.A. 48:2-13 et seq.

Effective Date: September 5, 1989.

Expiration Date: September 5, 1991.

**Summary of Public Comments and Agency Responses:**

COMMENT: New Jersey Bell Telephone Co. (NJB), AT&T, Operator Assistance Network (OAN), National Telephone Services (NTS), and International Telecharge, Inc. (ITI) suggest that N.J.A.C. 14:10-6.6 be amended to delete any reference to "00" dialed calls, since these calls have been assigned for use by interexchange carrier (IC) operator services. The comments suggest that "00" has been reserved for ICs as part of the North American Numbering Plan and that the proposed rules would cause confusion as well as extensive and expensive central office changes.

RESPONSE: The Board agrees with this comment and will change the wording of N.J.A.C. 14:10-6.6 accordingly. NJB began providing operator service in July 1988 (operator take-back), for intraLATA calling, which includes "0-" dialed calls. Under this arrangement, dialing "00" provides a connection to an IC for calls requiring a live operator. The

original intent of including "00" as part of the rules was to assure that all emergency calls would be handled properly, even those that may be misdialed. The comments suggest, and the Board agrees, that an end user is not likely to dial "00" for a local emergency. The Board has approved IC operator services where callers who inadvertently dial "00" for a local emergency, are instructed to hang-up and re-dial "0" to reach the local exchange company (LEC) operator. This procedure should be extended to the AOS providers as well. The wording of N.J.A.C. 14:10-6.6 will therefore be changed and the following language inserted: "End users who reach an AOS operator by inadvertently dialing "00" while attempting to reach a LEC operator for an emergency call shall be instructed to hang-up and dial zero (0)." This word change satisfies the original intent of the rule without causing the technical problem cited by commenters.

COMMENT: Telesphere International, Inc. (Telesphere), NY COM, Inc. (NYCOM), NTS and ITI argue that an AOS should not be required to connect end users to their carrier of choice. Commenters argue that it is not technically feasible to provide direct connections to every IC providing service in New Jersey. They suggest that free access to other carriers is appropriate and that they should be permitted to instruct callers to hang-up and re-dial the preferred carrier's access code. Commenters imply that this is the standard industry practice.

RESPONSE: The Board agrees in concept with the commenters' suggestion that an AOS provider be permitted the option of instructing the end user to hang-up and re-dial their preferred carrier's access code. This may create a situation where carriers would market their services and access codes, affording end users an even greater choice of carriers. N.J.A.C. 14:10-6.5 provides end users with the choice of operator service providers by prohibiting the blocking of access to other carriers. This is accomplished by requiring that free access to such carriers be provided. The Board does not wish to create a situation which is not technically feasible or reasonable to achieve by requiring a direct connection to every IC. A recent Federal Communications Commission (FCC) decision answering complaints against five AOS providers, effectively requires similar treatment by precluding certain AOS companies from call blocking or from splashing calls, where technically possible. See *In the Matter of Telecommunications Research and Action Center and Consumer Action v. Central Corporation; International Telecharge, Inc.; National Telephone Services, Inc.; Payline Systems, Inc.; and Telesphere Network, Inc.*, DA 89-237 (F.C.C. released February 27, 1989).

The Board notes here that the problem of "splashing" should be more clearly addressed in the proposed rules. Splashing occurs when an AOS provider transfers a call to another carrier at a foreign location and the caller's bill reflects a call originating from that foreign location which is unfamiliar to the caller. Although the practice of permitting AOS providers to instruct end users to hang-up and re-dial the preferred carrier's access code would replace the transferring of calls and the associated possibility of splashing, the Board believes it is necessary to completely eliminate the possibility of splashing. AT&T suggests the addition of the following language in an attempt to satisfy this concern: "In addition, upon request, the AOS will connect end users to their carrier of choice at the point of origination of the call." The Board agrees in concept with this language and will allow the AOS the option of connecting the end user to its carrier of choice, but only from the point of origination of the call, or requesting that the end user hang-up and re-dial. This change in language satisfies both the issues raised by the commenters as well as the Board's splashing concerns while not changing the intent of the rule.

COMMENT: Telesphere, NYCOM, NTS and ITI, all AOS providers, urge the Board to eliminate any differentiation between AOS providers and that of any other operator service provider. The commenters argue that any distinction between traditional and non-traditional and facilities-based and non-facilities-based carriers is anti-competitive, discriminatory and gives the traditional facilities-based carriers a competitive advantage. This competitive advantage, according to the comments, would benefit the "dominant" provider at the expense of the AOS provider even though both offer virtually the same services. The comments also suggest that the same rules should apply equally to all operator service providers including AT&T and NJB and the term AOS should be changed to "Operator Service Provider."

RESPONSE: The Board disagrees with this argument and will make no changes to N.J.A.C. 14:10-6.1 and N.J.A.C. 14:10-6.3. The Board is satisfied that sufficient protection is afforded end users of facilities-based carrier operator services through Board approved tariffs. AOS providers will be permitted to operate with as few restrictions as necessary as proposed herein, and will not be considered the same as traditional

carriers as described above. Therefore, the designation AOS will remain unchanged.

COMMENT: NYCOM and ITI have filed comments opposing N.J.A.C. 14:10-6.4(e) and (f), which holds the AOS provider responsible for placing dialing instructions and carrier notification on each instrument connected to the services of the AOS provider. In addition, ITI argues that N.J.A.C. 14:10-6.4(d) should only apply to the AOS provider with respect to regulations over which it has control. Commenters argue that their responsibility should be limited to supplying stickers and tent cards and claim that they do not have the ability to police every telephone connected to their network and that the burden of affixing and maintaining the stickers and tent cards on or near the instruments should be imposed directly upon the premises owner and pay telephone provider.

RESPONSE: The Board disagrees with this proposal and will make no changes to N.J.A.C. 14:10-6.4(d), (e) or (f). The AOS provider shall be responsible for all aspects of the provision of its service as a prerequisite to providing operator service in New Jersey. This requirement is not unique to the provision of AOS service in New Jersey, and is in conformance with similar regulations recently adopted by the FCC in the complaint proceeding against five AOS companies previously cited. In its decision, the FCC ordered the five defendants to comply with the following notification requirement: "First, the defendant AOS companies must provide consumer information to their customers in the form of tent cards, phone stickers, or some other form of printed documentation that can be placed on, or in close proximity to, all presubscribed phones." The Order further stated that: "Contracts with call aggregators must contain provisions requiring aggregators to display these materials on, or in close proximity to, all presubscribed telephones. In addition, the defendants must amend existing contracts with call aggregators to reflect this requirement. The defendants will bear primary responsibility for the implementation of the above-specified form of notice, and must make reasonable efforts to assure such implementation within sixty (60) days of the effective date of this Order."

COMMENT: AT&T has suggested that N.J.A.C. 14:10-6.9, which requires that a statement be placed on the end users bill stating that the AOS is not affiliated with the LEC supplying the bill, should include a similar disclaimer with respect to the customer's presubscribed long distance carrier. An AOS provider, ITI, argues that the requirement should not only apply to AOS providers, but to all IC's that provide operator service.

RESPONSE: The Board disagrees with these proposals and will make no changes to N.J.A.C. 14:10-6.9. The intent of this rule was to make a clear distinction between the AOS and the LEC, which is generally the billing agent. When a customer receives a bill from an unknown carrier or a bill that contains unknown charges, the customer associates the billing agent (LEC) with the billing charges (AOS charges). The proposed rule simply makes a clear delineation of these two entities. To include IC's in this disclaimer serves no purpose.

COMMENT: N.J.A.C. 14:10-6.4(f), which requires "branding", should be further clarified to require identification at the beginning of all operator assisted calls.

RESPONSE: The Board agrees with this comment and will clarify N.J.A.C. 14:10-6.4(f) to require that an AOS provider brand, or identify, itself at the beginning of, and prior to, the billing for all AOS handled calls. The Board believes it is essential that an AOS identify itself to the end user at the beginning of the call, that is, prior to the connection of the call and the implementation of billing. The intention of this rule is to inform end users which carrier they are dealing with, thus affording them the opportunity to decide whether to use that carrier or some other carrier prior to incurring any charges. If identification is made at the end of the call, or after the billing has been implemented, the intent of the rule would be defeated.

COMMENT: NJB argues that the definition of an AOS contained in N.J.A.C. 14:10-6.8(a) should be replaced with the definition of an AOS contained in N.J.A.C. 14:10-6.3. Their comments further state that an AOS provider does not necessarily apply to NJB for service, particularly intrastate interLATA service. For this reason, it suggests that the Board use the AOS definition contained in N.J.A.C. 14:10-6.3, for AOS Acknowledgement Forms as well.

RESPONSE: The Board disagrees and this definition will remain as published. This rule is intended to utilize NJB as the receiver of all Acknowledgement Forms for AOS service within the State of New Jersey, regardless of where the service is provided or whether the AOS provides interLATA or intraLATA service. The Board intends to ensure centralized administration of such forms and the language in N.J.A.C.

14:10-6.8(a) accomplishes that. Therefore, no change will be made to N.J.A.C. 14:10-6.8(a).

COMMENT: ITI seeks clarification of the Board's distinction between AOS providers and resellers contained in N.J.A.C. 14:10-6.4(c). The proposed rule specifically states that AOS providers are not considered resellers. ITI suggests that since it is dependent upon the facilities of others for switching and transmission within New Jersey, they should be considered a reseller.

RESPONSE: The Board rejects this comment. N.J.A.C. 14:10-6.4(c) distinguishes AOS providers from both resellers and facilities-based carriers as they are viewed as a separate and distinct service provider. From a network standpoint, it is true that AOS's provision their services in a fashion similar to that of a reseller. However, the current resale regulations do not adequately protect the public interest with respect to the provision of AOS. Therefore, rather than augmenting the resale regulations, the proposed rules were specifically designed for the AOS industry.

COMMENT: The Board should revisit the intraLATA ban during the 24 month period the AOS rules would be in effect. N.J.A.C. 14:10-6.2 states that the adopted rules are to remain in effect for 24 months at which time the Board will revisit any or all issues contained therein. ITI has requested that the Board reconsider the prohibition on intraLATA call completion contained in N.J.A.C. 14:10-6.4(a).

RESPONSE: The Board takes note of this request but will not pre-judge any aspect of these rules before the 24 months have elapsed.

COMMENT: ITI argues that AOS Acknowledgement Forms should be filed with the Board, rather than NJB. ITI argues that N.J.A.C. 14:10-6.8, by requiring the registration form to be filed with NJB, establishes NJB as both regulator and enforcer in a potentially competitive industry.

RESPONSE: The Board disagrees and will require that these forms be filed with NJB as proposed in the rules. N.J.A.C. 14:10-6.8 provides only that registration forms must be filed with NJB. No certification or registration approval is granted. NJB will simply collect and compile these forms and shall not have any "enforcement" or "policing" responsibilities. NJB similarly collects forms from resellers and private pay telephone owners. In those instances, NJB provides service to these providers and to date the Board has received no complaint alleging improper activity by NJB. AOS providers will not purchase such service from NJB, unless they are a reseller of intraLATA service, and the Board therefore does not anticipate any complaints with regard to AOS Acknowledgement Forms.

Full text of the adoption follows (additions to proposal indicated in boldface with asterisks \*thus\*; deletions from proposal indicated in brackets with asterisks \*[thus]\*).

## SUBCHAPTER 6. REGULATION OF ALTERNATIVE OPERATOR SERVICE (AOS) PROVIDERS

### 14:10-6.1 Scope

(a) The rules contained in this subchapter shall apply to the provision of Alternative Operator Service (AOS) as defined in N.J.A.C. 14:10-6.3, for any AOS provider or its agent in New Jersey other than a transmission or distribution facilities-based carrier.

(b) Federal regulatory policy in the telecommunications industry, as evidenced by the AT&T divestiture and other FCC decisions, has fostered competition in many segments of the telecommunications industry. New companies and technologies have arisen which were not contemplated when existing utility statutes and regulations were set in place. The Board has authorized competition in areas where it believes the benefits of competition will be flowed through to customers in New Jersey. A new area in which competition has recently arisen is in the provision of operator assistance. These rules may allow the benefits of the competitive marketplace to be more quickly flowed to consumers while ensuring that appropriate Board oversight and regulation is maintained.

### 14:10-6.2 Construction and amendment

This subchapter shall remain in effect for 24 months. The Board will revisit the matter at the end of 24 months to review and evaluate the effectiveness of these rules to determine if they should be continued, or to make any changes as are deemed necessary, including more stringent regulation.

### 14:10-6.3 Definitions

The following words and terms, when used in this subchapter, shall have the following meanings, unless the context indicates otherwise:

"Alternative Operator Service Provider" or "AOS" means any non-traditional telephone company operator service provider. This does not include AT&T, New Jersey Bell or any other tariffed transmission or distribution facilities-based carrier.

"Board" means the New Jersey Board of Public Utilities.

"LEC" means local exchange company.

### 14:10-6.4 Board regulation of AOS providers

(a) AOS providers may complete intrastate interLATA operator assisted calls over their network.

(b) AOS providers shall be subject to Board regulation on the basis of complaints from their customers. The Board or its staff may investigate the conduct of any AOS provider and take appropriate action as required.

(c) AOS providers and their agents shall not be considered resellers, except for AOS competitors providing intraLATA service in accordance with the provisions of this subchapter. In those instances, AOS providers are, in addition to the requirements of this subchapter, also subject to all the provisions contained in the Board's Orders in Docket Nos. 8112-1051 and 823-242.

(d) The AOS provider or its agent is responsible for conformance with all rules and regulations that apply to the provision of this service and the Board may take action against the AOS provider or its agent as is necessary to rectify any non-conformance with such rules, or to protect the general public interest. The Board's actions may include any necessary restrictions concerning billing and collection activities subject to its regulation.

(e) The AOS provider must place dialing instructions on instruments to which they provide service which detail AOS dialing procedures. These dialing instructions must include and be located in close proximity to dialing instructions for access to the local exchange company (LEC) operator.

(f) The AOS provider is responsible for including written notification of the carrier on or in close proximity to the telephone instrument, and branding must be provided **\*[for]\* \*at the beginning of\* all operator assisted calls \*prior to connecting the call and the implementation of billing\*.**

### 14:10-6.5 Access to AOS and other operator service providers

Free access to all other operator service providers must be made available from all instruments connected to an AOS. 10XXX access is to be made available from all Customer Provided Pay Telephone Service (CPPTS) instruments as well as other instruments, where technically capable. Otherwise, other reasonable access codes will be acceptable. **\*[In addition, the AOS will connect end users to their carrier of choice upon request.]\* \*The AOS shall have the option of connecting the end user to their carrier of choice at the point of origination of the call, or requesting that the end user hang-up and re-dial.\***

### 14:10-6.6 Emergency call handling

All "0-" calls, that is, calls originated by dialing "0" and no other digits within 4 seconds, **\*[and "00" dialed calls,]\*** are to be sent promptly and directly to the LEC operator serving that area. **\*End users who reach an AOS operator by inadvertently dialing "00" while attempting to reach an LEC operator for an emergency call shall be instructed to hang-up and dial zero (0).\*** In addition, an AOS provider may petition the Board to provide emergency call completion. If an individual AOS can certify that it is capable of handling emergency calls, following a petition to the Board detailing how the service will be provided, it shall be granted permission to do so. Each petition will be reviewed separately on its merits.

### 14:10-6.7 Completion of intraLATA calls

Completion of intraLATA calls is prohibited unless accomplished by a reseller of intraLATA LEC facilities, and completed entirely over resold intraLATA LEC facilities alone.

### 14:10-6.8 AOS Acknowledgment Forms

(a) An AOS Acknowledgment Form, similar to that completed by resellers, must be filed with New Jersey Bell (Company). This form

shall contain all the rules contained in this subchapter as well as the following statements:

—Authorized Alternate Operator Services (AOS) Provider— Denotes a communications competitor who has applied to the Company, and advises the Company of its intention to provide operator services in the State of New Jersey and via this signed "Letter of Acknowledgment" agrees to abide by the regulations set forth in such "Letter".

—The AOS shall acknowledge that only proper call measurement procedures will be used and that calls will be billed consistent with existing Company practice, that is, calls which are not completed are not billed.

—The AOS shall acknowledge that penalties for violations of the conditions of AOS may result in the imposition of penalties as stated in N.J.S.A. 48:2-42. The law provides that any person who willfully violates a Board of Public Utilities Order shall be guilty of a misdemeanor.

—The AOS shall notify the Company when it is no longer an intrastate AOS provider.

(b) The Company shall formulate an AOS Acknowledgment Form containing all AOS rules contained in this subchapter as outlined in (a) above.

#### 14:10-6.9 Customer billing

LECs that provide billing and collection services to AOS providers shall include a statement on the AOS portion of each customer's bill advising the customer that the competitive operator service provider is not affiliated with the LEC and the charges contained on the pages are not regulated by the Board.

## TRANSPORTATION

### (a)

#### DESIGN AND RIGHT OF WAY DIVISION OF TRAFFIC ENGINEERING AND LOCAL AID

##### Bureau of Electrical Engineering Release of Traffic Signal Information

##### Adopted New Rules: N.J.A.C. 16:26-1 Adopted Repeals: N.J.A.C. 16:26-2 and 3

Proposed: June 19, 1989 at 21 N.J.R. 1653(b).  
Adopted: July 25, 1989 by Robert A. Innocenzi, Acting  
Commissioner, Department of Transportation.  
Filed: August 7, 1989 as R.1989 d.458, **without change**.  
Authority: N.J.S.A. 27:1A-5 and 6.  
Effective Date: September 5, 1989.  
Expiration Date: September 5, 1994.

##### Summary of Public Comments and Agency Responses:

###### No comments received.

N.J.A.C. 16:26 expired on August 6, 1989 pursuant to Executive Order No. 66(1978). As the readoption of N.J.A.C. 16:26-1, was not filed with the Office of Administrative Law until August 7, 1989, that subchapter with amendments is adopted as new rules, in accordance with N.J.A.C. 1:30-4.4(f).

Full text of the adopted new rules follows.

#### CHAPTER 26 ELECTRICAL ENGINEERING

##### SUBCHAPTER 1. RELEASE OF TRAFFIC SIGNAL INFORMATION

###### 16:26-1.1 Requirements

(a) All requests for information concerning the operation or maintenance of traffic signals shall be referred to the Bureau of Electrical Engineering for processing.

(b) Requests for such information must be submitted in writing, accompanied by a check or money order for \$100.00 made payable to the New Jersey Department of Transportation.

(c) (No change.)

###### 16:26-1.2 Authorization

The Manager, Bureau of Electrical Engineering, may furnish information on traffic signals only if the requirements of N.J.A.C. 16:26-1.1 are observed. These requirements may be waived if the information is for official use of government agencies.

### (b)

#### NEW JERSEY TRANSIT CORPORATION Examination and Duplication of NJ TRANSIT Records

##### Adopted New Rules: N.J.A.C. 16:82

Proposed: February 6, 1989 at 21 N.J.R. 284(b).  
Adopted: July 27, 1989 by S. Thomas Gagliano, Executive  
Director, New Jersey Transit Corporation.  
Filed: August 8, 1989 as R.1989 d.462 **with substantive changes**  
not requiring additional public notice and comment (see  
N.J.A.C. 1:30-4.3).

Authority: N.J.S.A. 47:1A-2 and 27:25-20.

Effective Date: September 5, 1989.

Expiration Date: September 5, 1994.

##### Summary of Public Comments and Agency Responses:

COMMENT: The New Jersey Press Association (NJPA) requests that a public hearing be held prior to the promulgation of the proposed rules.

RESPONSE: The only comments received were from NJPA. Because there is no requirement for a hearing (N.J.S.A. 52:14B-4(a)(3)) and staff has met and discussed with NJPA their concerns, NJ TRANSIT does not believe a public hearing is necessary.

COMMENT: NJPA has grave concerns and strongly objects to the portion of the proposed rules that allows NJ TRANSIT to refuse to release certain information.

RESPONSE: NJ TRANSIT is a responsive open public agency which recognizes its obligations to the public. However, the "Right to Know Law", court decisions and the "Open Public Meeting Law" recognize that there are valid reasons for a public agency not to allow inspection and copying of certain of its records under certain circumstances. The intent of N.J.A.C. 16:82-2.2 is to set forth such records and circumstances. In addition, the Freedom of Information Act which governs the release of records kept by the Federal government also recognizes nine separate exemptions, some of which are similar to the NJ TRANSIT proposals. In reality, much of this information, depending upon the circumstances and the timing of the request, will be released. The procedure is the same as the New Jersey Department of Transportation's (NJDOT) set forth at N.J.A.C. 16:1-2.2(c) which has been in existence since 1969.

COMMENT: Future construction projects in terms of specific amounts, locations, or design criteria. This is information of vital concern to all members of the public who have every right to know what kinds of projects are planned by any public body and how much they are going to cost. If you were merely a member of the public, wouldn't you want to know if NJ TRANSIT planned to put a \$10 million five story bus station on your street?

RESPONSE: This exclusion is similar to NJDOT's (N.J.A.C. 16:1-2.2(c)1) and is designed to protect the public interest from the premature disclosure of future projects until they are ready for review by the public. Premature release of the specific amounts or type of a construction project could negatively impact the bidding to the public's detriment. Premature release of locations could impact the cost of real estate necessary for the project. Because of the nature of NJ TRANSIT's project approval and grant process, a major capital project simply cannot be constructed without adequate notice to affected members of the public and fair opportunity to comment.

COMMENT: Qualifications and classifications of contractors, consultants and appraisers. NJPA believes the public has every right to know the qualifications of persons hired by NJ TRANSIT. To preclude such information from the public cannot help but make one wonder if those being hired are not qualified.

**RESPONSE:** This exclusion is designed to protect and encourage vendors or potential vendors to qualify to bid on NJ TRANSIT's projects and thereby encourage competition. Certain of the information may be considered proprietary by such vendors who may not seek to qualify and bid if such information is available to the public. A contractor's pre-qualification classification will be released upon request.

**COMMENT:** Research and tests required in the development of materials, design and construction. Frankly, NJPA does not understand what NJ TRANSIT means in this section and believes this section needs to be more specific. This is an item that should be discussed and explained at a public hearing.

**RESPONSE:** This exclusion is designed to encourage research, development and tests which may not be undertaken if subject to premature public disclosure. It is also designed to safeguard proprietary information which may be developed or made available during the research and development process. At the completion of any such project, the results will be made available upon request.

**COMMENT:** Consultants' draft and final reports, NJ TRANSIT draft and final preliminary planning and engineering studies prior to disclosure at a public hearing. These are precisely the kinds of things that should be available prior to a public hearing, especially in the final preliminary stages so that those interested can decide whether or not to attend the public meeting and when they do, be able to discuss with NJ TRANSIT. Can one imagine, for example, attending a public hearing on a proposed school budget without having had an opportunity to review the budget (which must be published) prior to the hearing.

**RESPONSE:** This is the same as NJDOT's exclusion (N.J.A.C. 16:1-2.2(c)(4)). It is intended to prevent the premature disclosure of reports and studies until they are finalized internally. Once a report is finalized and a public hearing scheduled, the material will be made available to the public at least 30 days prior to the hearing as is the practice currently.

**COMMENT:** Engineering cost estimates. This needs to be more specific especially as to a time frame. NJPA can agree that NJ TRANSIT would not want to reveal these estimates prior to bidding but certainly after the bids are received, there should be no problem revealing the estimates.

**RESPONSE:** This information will not be released until after the award of a particular contract because it could immensely influence the bidding process. Such estimates will be released upon request after the award of a contract.

**COMMENT:** Proprietary information developed by NJ TRANSIT or submitted by vendors and bidders/proposers. Again, NJPA needs to be more specific and have this explained in more detail at a public hearing as to what kinds of proprietary information is needed to be kept confidential. What is proprietary and who decides and even if it is "proprietary" but has some danger to the public, shouldn't some of this information be public?

**RESPONSE:** Under certain circumstances such as single bid or sole source contracts, it is necessary for NJ TRANSIT to receive proprietary information from the bidder, in order to ensure either that it will get bids or that it is getting a fair price. If such information is subject to public disclosure, these vendors may be unwilling to bid or provide the information necessary to award a contract. Proprietary information includes but is not limited to such things as patents, copyrights, manufacturing or other processes and financial information.

**COMMENT:** Current and prior labor negotiation documents. This needs further explanation and elaboration. NJPA certainly would not want to force NJ TRANSIT to "show its hand" during labor negotiations but at some point, might not some of these documents be available after settlement? NJ TRANSIT may, in this case, have good and valid reasons but NJPA would think they should be heard at a public hearing.

**RESPONSE:** Final labor contracts are matters of public record and will be released upon request. NJ TRANSIT believes it is not in the public interest to release documents prepared for negotiations because of their possible negative impact on future negotiations and relations. This exclusion is consistent with the provisions of the Open Public Meetings Law which allows discussion of labor negotiations in closed session.

**COMMENT:** All negotiation documents pertaining to real estate transactions, procurement, change order, or other contract negotiations. Same question as above. NJ TRANSIT need not "show its hand" but certainly the final settlement should be public, which assumes it will be because this section discusses only negotiations.

**RESPONSE:** Final real estate and other contracts and change orders are public records and will be released upon request. Other documents

prepared for negotiations should not be released because of the possible negative impact on future negotiations. Real estate appraisals will be released upon request after a project has been finalized.

**COMMENT:** All accident and safety investigation reports. This section is of grave concern to NJPA. It would seem that these are precisely the kinds of reports that should be public especially to members of the public who ride NJ TRANSIT trains and buses. If, for example, an investigation report reveals that a train crashed because effective brakes failed and prior to the crash the problem was reported to maintenance but was ignored, or that an engineer was stone cold drunk when he crashed, the public is entitled to this information and the entire report to prevent even the appearance of selective disclosure.

(NJPA hopes that there are safeguards and the examples cited are so rare that they never will exist and by using them, NJPA is not suggesting or implying this is a situation at NJ TRANSIT. NJPA uses them only to make the point.)

**RESPONSE:** NJDOT excludes the release of preliminary aeronautical accident investigative reports (N.J.A.C. 16:1-2.2(c)(5)) as well as police and driver reports of accidents (N.J.A.C. 16:1-2.2(c)). The "Right to Know Law" (N.J.S.A. 47A-3) specifically provides that records of an investigation in progress may be denied if the release is deemed inimical to the public interest. The Open Public Meeting Law (N.J.S.A. 104-6) allows for the discussion in executive session of any tactics and techniques utilized in protecting the safety and property of the public or any investigations of violations or potential violations of the law. NJ TRANSIT believes that the proposed exclusion will encourage those involved in the investigations to be totally truthful and thereby provide information necessary to avoid future occurrences. NJ TRANSIT also recognizes the public's need to know the circumstances surrounding such investigations. Therefore, such reports or portions thereof may be released when finalized depending upon the facts and circumstances of each accident, the timing of each request and the identity of the requestor. Accident reports required by Federal or State law will be released upon request when authorized and finalized.

**COMMENT:** Personnel and pension records. To the information which can be disclosed, NJPA would add address (at the very least the town), and employment history.

**RESPONSE:** NJ TRANSIT agrees to add the town an employee lives in and employment history to the information that will be disclosed.

**COMMENT:** All records pertaining to workers' compensation, temporary disability and federal employer liability act matters. NJPA must defer to its attorneys on this point and this section may be okay except that the public may be entitled to know amounts of compensation and for what reasons.

**RESPONSE:** Depending upon the circumstances and timing of a request for such information, NJ TRANSIT may believe that an employee's right to privacy (medical records) and the agency's rights to keep claims and litigation matters confidential should take precedence over the public's right to know the details of such cases. Such an exclusion is consistent with the Open Public Meeting Act's provisions which allow discussion of claims and litigation and personnel matters in executive session. The final results in such cases will be made available upon request.

**COMMENT:** All records which are part of any workpapers, memoranda, or reports which are made, maintained, or kept by the Office of Internal Audit in NJ TRANSIT, including audit reports made by outside auditors, but not for the final audit or report required by N.J.S.A. 27-25-20(d). There may be valid reasons for keeping some confidential material secret but this section appears to be overboard and certain reports concerning financial operations of NJ TRANSIT in its conduct of the public's business should be deemed to be public records and available to the public and the press. It falls in the public area, especially those which may not be included in the public annual audit report. Further clarification and an explanation are necessary.

**RESPONSE:** This exclusion is also similar to NJDOT's (N.J.A.C. 16:1-22(c)9 and 12). The purpose of audits is to improve the way NJ TRANSIT runs its business. Therefore, this exclusion is designed to continue to encourage NJ TRANSIT to conduct audits and investigations and encourage employees to cooperate with such investigations or audits. Fears of premature and inappropriate disclosure of such information could result in a lack of cooperation from employees and worse could inhibit management's desire to audit and improve.

**COMMENT:** Research documents pertaining to ongoing studies for the operational areas of NJ TRANSIT prior to disclosure to the public. This seems to be a timing situation but the obvious question and concern is: will the documents and studies be closed and then because of an

arbitrary decision in the agency never be disclosed to the public? This is much too loose.

RESPONSE: This exclusion is designed to encourage research and to prevent the premature disclosure that may inhibit the research process.

COMMENT: All material, procedures and related documents regarding security of employees, the public, and NJ TRANSIT property and funds. This includes, but is not limited to, documents pertaining to the collection and deposit of farebox revenue. NJPA agrees that certain security matters need to be kept confidential for the protection of all above, especially the money, but NJPA thinks the public has a right to know that adequate security measures are being taken on their behalf, and should be able, through public disclosure, to substantiate that such matters as security guards on trains or buses and in train stations or bus stations or bus terminals, are adequate and competent.

RESPONSE: NJ TRANSIT collects over \$300 million in revenue a year in all kinds of ways and at all kinds of locations. In addition, the security of employees and riders is a priority which calls for certain investigative and security techniques which require confidentiality under certain circumstances. This exclusion is consistent with the provisions of the Open Public Meetings Law that allows for discussions in executive session of tactics and techniques utilized in protecting the safety and property of NJ TRANSIT.

COMMENT: Disadvantaged business enterprises and women's business enterprises classification questionnaires submitted as part of Federal and State goal and set aside programs. NJPA is frank to admit not knowing much if anything about these programs but absent very good reasons for doing so, why should they not be public?

RESPONSE: This exclusion is designed to protect and encourage vendors or potential vendors to qualify to bid on NJ TRANSIT projects in order to encourage competition. Certain of the information may be considered proprietary by such vendors who may not seek to qualify and bid if such information is available to the public. The fact that a particular firm is or is not a qualified Disadvantaged Business Enterprise or Women Business Enterprise will be made public.

COMMENT: Board items contained in the minutes of closed executive sessions and all materials forming the background from such board items, may be withheld from disclosure until the reason for discussing the item in closed session no longer exists. This sounds like a violation of both the spirit, if not the letter, of the open public records and open public meetings laws. As NJ TRANSIT probably knows, the open public meetings law requires that minutes be made promptly available to the public upon request.

RESPONSE: This provision is consistent and in accordance with the statutory provisions of the Open Public Meetings Law governing closed executive sessions (N.J.S.A. 10:4-12 and 13).

COMMENT: Administrative fees most certainly are permitted but they should be as low as possible and closely relate to the actual costs of copying documents. NJ TRANSIT might want to consider even lower prices perhaps starting at 25 cents for the first through 10th page and then drop to five cents for all pages over 20. NJPA has never known of a worker/hour charge for public records and submit that there be no charge for all reasonable and normal requests.

RESPONSE: The prices per copy set forth in N.J.A.C. 16:82-2.3(b) are the same as those authorized by N.J.S.A. 47:1A-2 which fees have been in existence since 1963. N.J.A.C. 16:82-2.3(d) is designed to compensate the agency for requests which require a significant amount of research and investigation and not just inspection and copying. If someone is going to make such requests, they should be willing to pay the full cost of providing the information.

COMMENT: Proposed N.J.A.C. 16:82-2.1(a) conditions access to records which are admittedly public records under the provision of N.J.S.A. 47:1A1 et seq. upon an "appointment" with the Assistant Executive Director for Labor Relations and Legal Affairs. NJPA can find nothing in N.J.S.A. 47:1A-1 et seq. which conditions access upon the making of an appointment. Indeed, N.J.S.A. 47:1A-2 expressly provides that "every citizen of this State, during the regular business hours maintained by the custodian of any such records, shall have the right to inspect such records." Thus, the only statutory requirement is that the access be exercised during regular business hours.

RESPONSE: NJ TRANSIT and its subsidiaries have offices and records at numerous locations throughout New Jersey. N.J.A.C. 16:82-2.1(a) is designed solely to ensure that the public access to NJ TRANSIT's public records is facilitated and handled in an orderly and organized way. While NJ TRANSIT believes a centralized contact will be more convenient, any member of the public will be shown during regular business hours any public records required to be made, main-

tained or kept on file by law at that location. The adopted rules provide that there is no requirement to make such an appointment.

COMMENT: N.J.A.C. 16:82-2.1(a) also indicates that the Assistant Executive Director for Labor Relations and Legal Affairs will "... determine the appropriate office where the records may be examined or obtained". NJPA is not sure the import of this sentence but to the extent that the designated officer may determine an examination shall occur at an office other than where the records are maintained, NJPA would submit such provision is inappropriate.

RESPONSE: Obviously members of the public may examine or obtain public records at the office where they are maintained. However, because NJ TRANSIT is actually composed of four separate entities with offices throughout New Jersey and the records requested may come from more than one entity or location, NJ TRANSIT believes the proposed rule is a more reasonable approach.

COMMENT: N.J.A.C. 16:82-2.2 contains a listing of 15 classifications of records which are "... not considered NJ TRANSIT public records". NJPA questions the classification of such records as not public records within the provisions of N.J.S.A. 47:1A-1 particularly in view of the fact that many of those records appear to be records "required by law to be made, maintained or kept on file ..." and thus, public records under the provisions of N.J.S.A. 47:1A-1.

RESPONSE: NJ TRANSIT has responded specifically to all of the NJPA's specific comments regarding the classification of records not considered public records.

Full text of the adoption follows (additions to proposal indicated in boldface with asterisks \*thus\*; deletions from proposal indicated in brackets with asterisks \*[thus]\*).

## CHAPTER 82 EXAMINATION AND DUPLICATION OF NJ TRANSIT RECORDS

### SUBCHAPTER 1. GENERAL PROVISIONS

#### 16:82-1.1 Purpose

The New Jersey Transit Corporation (NJ TRANSIT) and its subsidiaries are responsible for provision of rail and bus services in the State of New Jersey. As a State instrumentality, NJ TRANSIT must make its public records available, for examination and duplication, to requesting members of the public. This chapter governs the issuance and sale of copies of NJ TRANSIT public records.

#### 16:82-1.2 Definitions

The following words and terms, as used in this chapter, shall have the following meanings unless the context clearly indicates otherwise.

"Fee" means the assessment of administrative costs plus any applicable costs of record duplication.

"NJ TRANSIT" means the New Jersey Transit Corporation or any of its subsidiaries.

"NJ TRANSIT public records" means "public records" as defined in N.J.S.A. 47:1A-2 and N.J.S.A. 27:25-20, except as excluded in N.J.A.C. 16:82-2.2 maintained by NJ TRANSIT.

### SUBCHAPTER 2. REQUIREMENTS

#### 16:82-2.1 Examination of NJ TRANSIT public records

(a) All NJ TRANSIT public records may be examined by members of the public\*[,]\* **\*either\*** by appointment\*[,]\* during the regular business hours of the Assistant Executive Director for Labor Relations and Legal Affairs**\*or by demanding the right to inspect such records during the regular business hours maintained by a particular custodian of any such records\***. Every citizen of the State also has the right to purchase copies of these public records. The Assistant Executive Director for Labor Relations and Legal Affairs will determine the appropriate office where the records may be examined or obtained **\*unless the member of the public demands that the records be made available at the exact location where the records are maintained\***.

(b) The right of examination of public records pursuant to N.J.S.A. 47:1A-3 may be denied in cases where the records being sought for examination pertain to any investigation by NJ TRANSIT in progress, if the inspection, copying, or publication of these records is not in the best interest of the public.

## 16:82-2.2 Non-public records

(a) Certain records are not considered "NJ TRANSIT public records", and may be made available for examination and purchase only by an individual who demonstrates to the Assistant Executive Director for Labor Relations and Legal Affairs that the person has a legitimate beneficial interest in such a record or the protection of his or her property rights or the protection of any interest the citizen may have in any matter affecting the citizen to which said record is relevant. Such non-public records include those pertaining to:

1. Future construction projects in terms of specific amounts, locations, or design criteria.

2. Qualifications and classifications\*, questionnaires and other documentation required\* of contractors, consultants, and appraisers. \*The actual qualification or classification will be made available.\*

3. Research and tests required in the development of materials, design and construction. \*At the completion of any such project, the results except for proprietary information will be made available upon request.\*

4. Consultants' draft and final reports, NJ TRANSIT draft and final preliminary planning and engineering studies prior to disclosure at public hearing.

5. Engineering cost estimates \*prior to contract execution\*.

6. Proprietary information developed by NJ TRANSIT or submitted by vendors and bidders/proposers.

7. Current and prior labor negotiation documents. \*Final labor contracts will be made available upon request.\*

8. All negotiation documents pertaining to real estate transactions, procurement, change order, or other contract negotiations. \*Final agreements and change orders will be made available upon request.\*

9. \*[All]\* \*Preliminary\* accident and safety investigation reports. \*All accident reports required by agencies regulating NJ TRANSIT shall be made available when final and if not prohibited by the regulatory agency.\*

10. Personnel and pension records, except that the following can be made "public":

i. An individual's name, \*town of residence,\* title, position, salary, payroll record, length of service, \*employment history,\* date of separation from agency, and the amount and type of pension the individual is receiving.

ii. Data which disclose conformity with specific experimental, educational or medical qualifications required for agency employment or receipt of a public pension, but under no circumstances will detailed medical or psychological information be released.

11. All records pertaining to Worker's Compensation, Temporary Disability, and Federal Employer Liability Act matters.

12. All records which are part of any workpapers, memoranda, or reports which are made, maintained or kept by the Office of Internal Audit in NJ TRANSIT, including audits or reports made by outside auditors.\* \* [but not for the] \* \*The\* audit or report required by N.J.S.A. 27:25-20(d) \*shall be made available upon request\*.

13. Research documents pertaining to ongoing studies for the operational areas of NJ TRANSIT prior to disclosure to the public.

14. All materials, procedures, and related documents regarding the security of employees, the public, and NJ TRANSIT property and funds. This includes, but is not limited to, documents pertaining to the collection and deposit of fare-box revenue.

15. Disadvantaged Business Enterprises and Women's Business Enterprises classification questionnaires submitted as part of Federal and State goal and set-aside programs. \*Any document indicating that a particular company is or is not a Disadvantaged Business Enterprise or Women's Business Enterprise will be made available.\*

(b) The records listed below are also not considered NJ TRANSIT public records and are subject to the provisions of N.J.S.A. 20:3-12(c) and (d) and the New Jersey Court Rules.

1. Estimates, appraisals and costs of acquiring property prior to the completion of a project.

2. For the preservation of the "attorney-client privilege," all records which are part of any case file maintained by a Deputy Attorney General or Special Counsel representing NJ TRANSIT.

(c) Board items contained in the minutes of closed executive sessions, and all material forming the background for such board

items, may be withheld from disclosure until the reason for discussing the item in closed session no longer exists.

(d) Portions of "non-public" records may be made available for examination or copying at the discretion of the Assistant Executive Director for Labor Relations and Legal Affairs where the interests of NJ TRANSIT \*or its employees\* are not otherwise negatively affected by such disclosure.

## 16:82-2.3 Administrative fees

(a) The citizen requesting to examine NJ TRANSIT public records shall pay fees established by NJ TRANSIT as set forth in this section.

(b) Costs are as follows:

1. For copies of 8½ inch by 11 inch and 11 inch by 14 inch

i. First page to 10th page, \$0.50 per page.

ii. Eleventh page to 20th page, \$0.25 per page.

iii. All pages over 20, \$0.10 per page.

2. For magnetic tapes, computer-sized paper, maps, charts, etc., costs are vendor's charge, that is, fees charged by an outside firm to make copies.

(c) If the Assistant Executive Director for Labor Relations and Legal Affairs finds that there is no risk of damage, mutilation, or loss of such records, and that it will not be incompatible with the economic and efficient operation of NJ TRANSIT and the transaction of its public business, he or she may permit any citizen who is seeking the copy more than 100 pages of records to use his or her own photographic process, approved by the Assistant Executive Director for Labor Relations and Legal Affairs, upon the payment of a reasonable fee, considering the equipment and the time involved, of not less than \$5.00 or more than \$25.00 per day.

(d) When the Assistant Executive Director for Labor Relations and Legal Affairs makes available records that involve a significant amount of research and investigation, additional charges may be imposed to reimburse NJ TRANSIT for the cost of conducting this research and investigation. Cost will be calculated on a worker/hour basis. These charges will be in addition to the charges in (b) and (c) above.

## 16:82-2.4 Procedure for copy request or record examination

A private citizen may request a copy of a NJ TRANSIT public record, or make an appointment to examine such a record, by contacting:

Assistant Executive Director  
for Labor Relations and Legal Affairs  
NJ TRANSIT  
P.O. Box 10009  
Newark, NJ 07101  
Telephone (201) 643-7130.

## TREASURY-GENERAL

## (a)

## DIVISION OF PENSIONS

## State Health Benefits Program

## Effective Dates; Coverage

## Adopted Repeals and New Rules: N.J.A.C. 17:9-2.6 and 2.7

Proposed: June 5, 1989 at 21 N.J.R. 1503(a).

Adopted: August 10, 1989 by the State Health Benefits

Commission, Patricia Mastrocola, Acting Secretary.

Filed: August 14, 1989 as R.1989 d.469, **without change.**

Authority: N.J.S.A. 52:14-17.27.

Effective Date: September 5, 1989.

Expiration Date: October 3, 1993.

## Summary of Public Comments and Agency Responses:

**No comments received.**

**Full text of the adoption follows.**

17:9-2.6 Effective date; State employees and dependents

For State employees and their dependents for whom an enrollment application has been filed with the Division of Pensions, coverage is effective on the first day of the fifth payroll period of employment for a sub-group which reports on a bi-weekly basis, or the first day following the completion of two months of continuous service for a sub-group which reports on a monthly basis. If employee deductions are required for HMO coverage, deductions begin on the first day of the third payroll period of employment for bi-weekly sub-groups and approximately one month prior to the effective date of coverage for monthly sub-groups.

17:9-2.7 Effective date; local employees and dependents

For local employees and their dependents for whom an enrollment application has been filed with the Division of Pensions, coverage is effective on the first day following the completion of two months of continuous service. If employee deductions are required for HMO or dependent coverage, deductions begin approximately one month prior to the effective date of coverage.

**(a)**

**STATE INVESTMENT COUNCIL**

**Common and Preferred Stocks and Issues  
Convertible into Common Stock**

**Adopted Amendment: N.J.A.C. 17:16-17.3**

Proposed: July 3, 1989 at 21 N.J.R. 1821(b).

Adopted: August 10, 1989 by Roland M. Machold, Director,  
Division of Investment.

Filed: August 10, 1989 as R.1989 d.466, **without change**.

Authority: N.J.S.A. 52:18A-91.

Effective Date: September 5, 1989.

Expiration Date: December 2, 1990.

**Summary of Public Comments and Agency Responses:**

**No comments received.**

**Full text of the adoption follows.**

17:16-17.3 Limitations

(a) The book value of total investments in common and preferred stock for any one of the funds listed in N.J.A.C. 17:16-17.2 shall not exceed 40 percent of the book value of such fund, with the exception of Common Pension Fund A.

(b)-(c) (No change.)

**OTHER AGENCIES**

**(b)**

**PUBLIC EMPLOYMENT RELATIONS COMMISSION**

**Petitions for Rulemaking by Interested Persons**

**Adopted New Rule: N.J.A.C. 19:10-6.1**

Proposed: May 2, 1989 at 21 N.J.R. 1505(a).

Adopted: July 31, 1989 by the Public Employment Relations  
Commission, James W. Mastriani, Chairman.

Filed: August 8, 1989 as R.1989 d.461, **without change**.

Authority: N.J.S.A. 34:13A-5.9, 52:14B-4(f) and N.J.A.C.  
1:30-3.6.

Effective Date: September 5, 1989.

Expiration Date: September 5, 1994.

**Summary of Public Comments and Agency Responses:**

**No comments received.**

**Full text of the adoption follows.**

**SUBCHAPTER 6 RULEMAKING PETITIONS FILED BY  
INTERESTED PERSONS**

19:10-6.1 Rulemaking petition procedures

(a) Any interested person may petition the Commission to make, amend or repeal any rule. The petition must be written and signed by the petitioner.

(b) The petition shall state the following clearly and concisely:

1. The name of the person making the request;
2. That person's interest in the request, including any relevant organizational affiliation;
3. The substance or nature of the rulemaking requested;
4. The proposed text of the rule;
5. The reasons for the request;
6. The statutory authority for the Commission to take the requested action; and
7. Any existing State or Federal law or regulation which may be pertinent.

(c) Requests shall be addressed to:

Chairman  
Public Employment Relations Commission  
CN 429  
495 West State Street  
Trenton, NJ 08625-0429

(d) Within 15 days of receiving the petition, the Commission shall file with the Office of Administrative Law the notice of petition required by N.J.A.C. 1:30-3.6(a).

(e) The petition shall be provided to the Commission at the next monthly meeting after filing.

(f) Within 30 days of receiving that petition, the Commission shall mail to the petitioner, and file with the Office of Administrative Law for publication, the notice of action on the petition required by N.J.S.A. 52:14B-4(f) and by N.J.A.C. 1:30-3.6(b) and (c).

**(c)**

**CASINO CONTROL COMMISSION**

**Accounting and Internal Controls  
Licensee's System of Internal Controls**

**Adopted Amendment: N.J.A.C. 19:45-1.3**

Proposed: June 5, 1989 at 21 N.J.R. 1506(a).

Adopted: August 2, 1989 by the Casino Control Commission,  
Walter N. Read, Chair.

Filed: August 3, 1989 as R.1989 d.457, **without change**.

Authority: N.J.S.A. 5:12-63(c), 99(a) and 99(b).

Effective Date: September 5, 1989.

Expiration Date: March 24, 1993.

**Summary of Public Comments and Agency Responses:**

**COMMENT:** The Division of Gaming Enforcement supports the proposed amendment to N.J.A.C. 19:45-1.3.

**RESPONSE:** Accepted.

**Full text of the adoption follows.**

19:45-1.3 Licensee's system of internal control

(a) Each casino licensee shall submit to the Commission and Division a description of its system of internal procedures and administrative and accounting controls as part of the requirement of Section 99 of the Casino Control Act. Such submission shall be made at least 120 days before gaming operations are to commence, unless otherwise directed by the Commission. Each such submission shall contain both narrative and diagrammatic representations of the internal control system to be utilized by the licensee.

(b) (No change.)

(c) Each casino licensee shall submit to the Commission and the Division any changes to the system of internal procedures and administrative and accounting controls previously determined by the Commission in (b) above to be adequate in all respects at least 90 days before the changes are to become effective, unless otherwise directed

## ADOPTIONS

by the Commission. The proposed changes shall be submitted to the Commission and such changes may be approved or disapproved by the Chairman unless any Commissioner indicates the changes should be considered by the entire Commission in which case such changes shall be so considered. No casino licensee shall alter its internal controls unless and until such changes are approved. However, the Commission shall make a determination concerning a submission for

## OTHER AGENCIES

changes in previously submitted control plans no later than 90 days following receipt of the submission unless the Commission and the casino licensee agree to extend the period for making such a determination. If there is no determination made within 90 days and there is no agreement to extend the period for making such a determination, then the submission shall be deemed to be approved.  
(d) (No change.)

---

# EMERGENCY ADOPTIONS

## TREASURY-GENERAL

(a)

### COMMERCE, ENERGY & ECONOMIC DEVELOPMENT

#### DIVISION OF PURCHASE AND PROPERTY, PURCHASE BUREAU

#### DIVISION OF BUILDING AND CONSTRUCTION DIVISION OF DEVELOPMENT FOR SMALL BUSINESS, AND WOMEN AND MINORITY BUSINESS

#### Purchase Bureau

#### Goods and Services Contracts for Small Businesses, Urban Development Enterprises and Micro Businesses

#### Minority and Female Subcontractor Participation in State Construction Contracts

#### Adopted Emergency Readoption with Amendments and Concurrent Proposed Readoption with Amendments: N.J.A.C. 17:12 and 12A:10-1

#### Adopted Joint Emergency Readoption and Recodification with Amendments and Concurrent Proposed Joint Readoption and Recodification with Amendments: N.J.A.C. 17:12-6 to 17:13

#### Adopted Joint Emergency New Rules and Concurrent Proposed Joint New Rules: N.J.A.C. 17:14 and 12A:10-2

Emergency Readoptions, Recodification and New Rules Adopted: August 14, 1989 by Feather O'Connor, State Treasurer, and Edward J. Trawinski, Acting Commissioner, Department of Commerce, Energy and Economic Development.

Authority: N.J.S.A. 52:18A-30(d), 52:25, 52:34-6 et seq., 52:32-17 et seq., 52:27H-6(f), 52:34-12(d), 10:5-36(k) and (o), 52:34-13, Executive Orders No. 34 (1976) and No. 189 (1988).

Gubernatorial Approval (see N.J.S.A. 52:14B-4(c)): August 14, 1989.

Emergency Readoptions, Recodification and New Rules Filed: August 14, 1989 as R.1989 d. 481.

Emergency Readoptions, Recodification and New Rules Effective Date: August 14, 1989.

Emergency Readoptions, Recodification and New Rules Expiration Date: October 13, 1989.

Concurrent Proposal Number: PRN 1989-473.

Submit comments regarding N.J.A.C. 17:12 by October 5, 1989 to: James J. Rosenberg, Director  
Division of Purchase and Property  
Department of the Treasury  
135 West Hanover Street, CN 230  
Trenton, New Jersey 08625

Submit comments regarding N.J.A.C. 17:13 and 14 and 12A:10-1 and 2 by October 5, 1989 jointly to:

Bernard McBride, Executive Assistant  
to the Commissioner's Office  
Department of Commerce, Energy and Economic Development  
20 West State Street, CN 820  
Trenton, New Jersey 08625

Lana T. Sims, Assistant State Treasurer  
Office of the Treasurer  
Department of the Treasury  
125 West State Street, CN 002  
Trenton, New Jersey 08625

The agency proposal follows:

#### Summary

In accordance with the "Sunset" and other provisions of Executive Order No. 66 (1978), N.J.A.C. 17:12 and 12A:10 are due to expire on August 15, 1989. The Department of the Treasury proposes to readopt with amendments N.J.A.C. 17:12 concerning the procedures for bidding for supplies and services necessary for the administration of State Government. The State Treasury, with the Department of Commerce, Energy and Economic Development, also proposes to readopt with amendments N.J.A.C. 17:12-6 (to be separately recodified at N.J.A.C. 17:13 and 17:14), which governs the awarding of State agency purchase and construction contracts to small businesses, female-owned and minority-owned businesses. The Department of Commerce, Energy and Economic Development proposes to readopt with amendments N.J.A.C. 12A:10-1, which is identical to N.J.A.C. 17:13 as herein proposed, and to adopt as new rules N.J.A.C. 12A:10-2, which is identical to proposed new rules N.J.A.C. 17:14. These proposed readoptions with amendments are necessary to permit the business of the State to continue without interruption.

These rules implement the various bidding and award requirements imposed on State purchasing contracts by State law. The requirements have remained basically unchanged; however, recent statutory changes and judicial decisions require the proposed readoption with amendments. Some of the proposed amendments are technical in nature; some are substantive. A summary of the text of N.J.A.C. 17:12, 17:13 and 17:14 follows:

N.J.A.C. 17:12-1 describes the organization of the Purchase Bureau, which has primary responsibility for State purchasing. This subchapter has been amended to comply with a statutory change regarding the aggregate amount of a contract which would permit it to be waived without public advertisement. This subchapter also allows the Director of the Division of Purchase and Property to authorize the award of contracts on the basis of line item, term contract, multi-source contract and waiver of advertisement. Definitions of "multi source contracts", "day" and "waiver of advertisement" have been added.

N.J.A.C. 17:12-2 describes the bidding procedures. It has been amended to require that the Division provide at least five working days notice in advance of the bid opening date and time if there is any modification to any of the terms, conditions or requirements of a request for proposal. It will permit the submission of an irrevocable letter of credit in lieu of other forms of security, permit stipulated awards to be made by the Director of the Division of Purchase and Property in certain cases, and clarifies what constitutes a bona fide signature on a bid document. This subchapter has been amended to include telephone, telegraph and telefacsimile bids as causes for automatic bid rejections, and clarifies the procedures for handling bid pricing errors and bid openings. In fiscal year 1988, the Purchase Bureau awarded approximately \$930 million in total purchases for State agencies.

N.J.A.C. 17:12-3 describes the hearing procedures wherein interested bidders may protest the intent to award a proposed contract. The hearings are conducted through the Office of the Director of the Division of Purchase and Property. This subchapter has been amended to allow the Director to waive an informal hearing and publish a final decision. Approximately 90 hearings are held per year.

N.J.A.C. 17:12-4 describes the agency complaints procedures, whereby State agencies may seek remedies for contract violations and contract performance problems. The Purchase Bureau receives approximately 300 complaints per year.

N.J.A.C. 17:12-5 describes cooperative purchasing and the participation in State contracts by political subdivisions and independent institutions of higher education. This subchapter has been amended to include volunteer fire departments, volunteer first aid or rescue squads, county colleges, State colleges, quasi-State agencies and independent authorities. There are approximately 712 subscribers to this program.

N.J.A.C. 17:12-6 is being jointly proposed by the Department of the Treasury and the Department of Commerce, Energy and Economic Development, with amendments and recodified at N.J.A.C. 17:13, Procurement and in new rules N.J.A.C. 17:14, Construction. The text of Chapters

13 and 14 are being separately adopted herein by the Department of Commerce, Energy and Economic Development at N.J.A.C. 12A:10. N.J.A.C. 17:12-6 presently establishes set asides for State procurement and construction contracts for small businesses, women and minorities, implementing N.J.S.A. 52:32-21 et seq.

In *City of Richmond v. J.A. Croson Company*, 488 U.S. \_\_\_, 109 S.Ct. 706, 102 L.Ed. 2d 854 (1989), the United States Supreme Court held that a minority set aside program administered by the City of Richmond violated the 14th Amendment. Upon review of *City of Richmond*, the Attorney General has advised that those provisions of N.J.S.A. 52:32-21 and N.J.A.C. 17:12-6 establishing set asides based on race lack the necessary evidentiary predicate establishing a compelling State interest in eradicating prior discrimination, and are not a sufficiently narrowly tailored remedy for actual identified discrimination. The Attorney General has likewise determined that the gender-based set aside established by N.J.S.A. 52:32-21 et seq. and N.J.A.C. 17:12-6 are similarly invalid when justified by the existing factual record.

The amendments proposed at N.J.A.C. 17:13 establish a set aside program for purchase contracts based on race- and gender-neutral categories. The previous rules described the procedures for businesses to qualify for bidding on contracts set aside for small businesses, minority businesses, and female businesses; established goals of 15 percent, seven percent, and three percent for each category respectively; and described the procedures State agencies must follow in implementing the set aside program. The proposed amendments delete the minority and female business categories of set asides, and establish two new categories of businesses, urban development enterprises and micro businesses, leaving undisturbed the small business category. The rules establish a seven percent goal for urban development enterprises and a three percent goal for micro businesses. The small business portion of these rules is not impacted by the proposed changes.

Urban development enterprises are defined as independently owned and operated businesses having no more than 50 full-time employees whose principal place of business is located in a municipality qualified under the Urban Development Corporation Act. A micro business is defined as an independently owned and operated business having no more than 20 full-time employees.

The rules proposed at N.J.A.C. 17:14 establish a procedure to guarantee that State construction contractors engage in market outreach efforts and do not presently discriminate against minority and female businesses in the awarding of construction subcontracts. They do not seek to remedy past discrimination and do not assume that any contractor is engaged in unlawful discrimination. The proposed rules establish that the criteria for determining the responsibility of a bidder include nondiscrimination in the selection of subcontractors and engaging in market outreach efforts.

Each construction contract will be reviewed and target levels set for female and minority subcontractor utilization for the particular contract. In addition, reasonable market outreach efforts will be identified for the contract. The subcontractor target levels will not function as goals but rather as screening devices to identify those bidders whose subcontracting practices will be subject to further scrutiny. Bidders who achieve the subcontractor target participation levels will not be subject to further review of their subcontracting practices. The subcontracting practices of bidders failing to meet target levels shall be reviewed to determine whether minority and/or female-owned firms were treated in a nondiscriminatory manner. If said review reveals discriminatory subcontracting practices by the bidder or if the bidder fails to engage in reasonable market outreach efforts the bidder will be disqualified from bidding on the particular contract.

The proposed rules describe eligibility standards for minority and female construction contractors; registration and approval procedures for minority and female businesses; procedures for challenging a registered business; obligations to provide information; and establish the requirement for an annual review of the operation and continuing need for the program.

N.J.A.C. 17:12-7 describes the procedures for suspension, disbarment and disqualification of vendors for various causes. Suspensions are processed by the Office of the Attorney General, and debarments are heard as contested cases at the Office of Administrative Law. Debarments are authorized by Executive Order No. 34 (1976) and No. 189 (1988). This subchapter has been amended to comply with Executive Order No. 189 which provides standards proscribing conflicts of interest on the part of present and prospective State vendors. Approximately five vendors are suspended or debarred each year.

### Social Impact

The readoption with amendments and recodification of N.J.A.C. 7:12 and 12A:10 will have a significant beneficial social impact upon the general public. N.J.A.C. 17:12-1, 2, 3, 4, 5, and 7 implement the basic statutory purposes of N.J.S.A. 52:34-6 et seq. of getting the best possible product at the best possible price for the State as expeditiously and efficiently as possible while treating all vendors equally and fairly, and guarding against favoritism, improvidence, extravagance and corruption.

The amendments proposed at N.J.A.C. 17:13 and 12A:10-1 recognize the State's interest in the vitality of all sectors of the economy and the importance of encouraging growth and competitiveness in the small entrepreneurial sector. Stimulating the growth of small business located in the urban centers complements the overall redevelopment effort and should help to alleviate the economic decline and social problems associated with urban areas.

The rules proposed at N.J.A.C. 17:14 and 12A:10-2 recognize the State's interest in eliminating unlawful discrimination based on race and gender and encouraging affirmative action in the construction contracting area. The elimination or reduction of discrimination along with the provision of outreach measures has a positive social impact and fosters equal opportunity.

### Economic Impact

The rules affected by this proposal will enhance the efficiency and cost effectiveness of operating State government and political subdivisions, thus resulting in a positive economic impact for the State. In Fiscal Year 1988, the Division of Purchase and Property awarded purchase contracts totalling approximately \$930 million, consisting of an estimated 3,500 term contracts and over 3,000 line item procurements. The Purchase Bureau has a significant effect on State government budget and on the economy of the whole State. Most of these contracts are awarded through competitive bidding. These rules assist in the implementation of cost saving measures through the competitive process and attempt to reconcile the State government's purchasing process with the State government's needs and the operation of the general economy.

The amendments proposed at N.J.A.C. 17:13 will contribute to the long-term economic growth of the State and help support the State's redevelopment initiatives. The growth potential of the businesses taking part in the set-aside program should be enhanced, thereby creating job opportunities and generating additional tax revenue.

The adoption of N.J.A.C. 17:14 will help ensure equal opportunity for minority and female businesses in securing construction contracts. This will improve the growth potential of such firms, thereby creating job opportunities and generating additional tax revenue.

### Regulatory Flexibility Analysis

The proposed readoption with amendments of N.J.A.C. 17:12 affects all persons and entities that bid for contracts with the State for supplies and services. Many such bidders are small businesses as defined under the Regulatory Flexibility Act, N.J.S.A. 52:14B-16 et seq. No reporting or record keeping requirements are imposed by the rules. The bidding procedure compliance requirements are necessary in order to insure a fair, competitive system for State purchases. Besides the bid and performance security requirements, necessary both as sound business practice and to protect the expenditure of public funds, the rules should impose no capital costs upon bidders beyond those normally incurred in the course of contracting in their respective business areas. No need for the engagement of professional services in the bidding process is anticipated. Special provisions for certain small businesses are set forth in proposed N.J.A.C. 17:13 and 14 and 12A-10.

Proposed N.J.A.C. 17:13 will have a positive impact on small businesses employing 100 or fewer people. There are no additional paperwork requirements for those businesses already registered as small businesses or those wishing to register. Businesses currently registered with the Department of Commerce as set aside vendors in categories other than small will have minimal paperwork to complete. Minority and female businesses wishing to become eligible in the newly established categories will have substantially less difficulty in registering.

Proposed N.J.A.C. 17:14 establishes additional paperwork requirements for construction firms bidding on State contracts. Bidders will be required to submit a minimum of two additional forms listing minority and female companies whose price quotes are included in the bid and the market outreach efforts undertaken. Bidders who fail to meet target levels will be required to submit an additional form detailing their solicitation of price quotes from minority and female subcontractors and suppliers. It is anticipated that the additional time and cost of this

required paperwork will be minimal and, in any event, will be far outweighed by the substantial public benefits generated by this program.

Full text of the proposed readoptions can be found in the New Jersey Administrative Code at N.J.A.C. 17:12 and 12A:10-1.

Full text of the amendments to the readoption and new rules follows (additions indicated in boldface thus; deletions indicated in brackets [thus]).

17:12-1.1 General [cause] **course** and method of operation

(a) (No change.)

(b) The Purchase Bureau is under the direct supervision of the Director of the Division of Purchase and Property, who is charged with the responsibility of making contracts or agreements and writing orders, the price of which is to be paid with or out of State funds. If the aggregate amount involved does not exceed [\$2,500] **the threshold established pursuant to N.J.S.A. 52:34-7**, any purchase, contract, or agreement may be made, negotiated or awarded by the Director without advertising in any manner which he may deem effective and practicable to permit full and free competition.

(c) When the aggregate amount exceeds [\$2,500] **the threshold established pursuant to N.J.S.A. 52:34-7**, specifications and invitations for bid shall permit such full and free competition as is consistent with the procurement of supplies and services necessary to meet the requirements of the using agency. Any such purchase, contract or agreement where the cost or contract price exceeds [\$2,500] **the threshold referenced above** may, with the written approval of the State Treasurer, be made, negotiated, or awarded by the Director of the Division of Purchase and Property without advertising when the subject matter thereon is that described in N.J.S.A. 52:34-9 and 52:34-10.

(d) (No change.)

(e) **When deemed to be in the best interest of the State, the Director may authorize the award of contracts on the following basis:**

1. **Line item;**
2. **Term contract;**
3. **Multi source contract; or**
4. **Waiver of Advertising.**

17:12-1.2 Source for public information

(a) The public may receive information concerning the State purchase program and invitations to bid by contacting the Director of the Division of Purchase and Property, [State House] **135 West Hanover Street, Room 112**, Trenton, New Jersey 08625.

(b) **Subsequent to bid opening, all bid documents are considered public information, notwithstanding any other disclaimers submitted by the bidder to the contrary.**

17:12-1.3 Definitions

These words and terms, when used in this subchapter, shall have the following meanings unless the context clearly indicates otherwise.

- ... **"Day"** means working day unless specifically noted otherwise.
- ... **"Multi source contracts"** means a commodity or service awarded to two or more bidders required to meet the needs of agencies in accordance with the provisions of N.J.S.A. 52:34-12.1. The Director shall take into consideration such factors as delivery and pickup locations, quantities, compatibility and cost, etc.
- ... **"Waiver of advertising"** means a contract awarded without public advertisement pursuant to the provisions of N.J.S.A. 52:34-9 and 52:34-10.

17:12-2.1 Advertised bids

(a) When advertising is required, the advertisement for bids shall be placed in such newspaper or newspapers selected by the Director, Division of Purchase and Property as will give best notice thereof to bidders. Advertisements shall be made a minimum of 10 working days in advance of the bid opening in order to permit competitive bidding.

(b) **If during the course of a purchase advertised pursuant to (a) above, it becomes necessary to alter any of the terms, conditions, or requirements of the request for proposal, such amendments shall be advertised a minimum of five working days in advance of the bid opening date and time.**

17:12-2.2 Bid [bonds] security

(a) The Director or his designee may require [in writing a bid deposit or bid bond prior to bid solicitation] **bid security** where, in his or her opinion, it is determined that security is warranted, based upon a review of market conditions and an evaluation of potential risk to the State.

(b) Bid security, in such an amount as the Director or his designee deems necessary, shall consist of a certified or cashier check drawn to the order of the Treasurer of the State of New Jersey, an individual or annual bid bond issued by an insurance or security company authorized to do business in the State of New Jersey, **or an irrevocable letter of credit shall be drawn naming the State Treasurer, State of New Jersey as beneficiary issued by a Federally insured financial institution.**

17:12-2.3 Performance [bond] security

(a) Performance security may be required by the Director, Division of Purchase and Property **or his designee in such an amount** on any award for a term contract or line item purchase in which the Director **or his designee, [in] at his discretion, feels that such security is warranted.** [Performance] **The performance security shall consist of a certified or cashier's check drawn to the order of the Treasurer of the State of New Jersey [or], an individual or annual performance bond [insured] issued by an insurance or security company authorized to do business in the State of New Jersey, or an irrevocable letter of credit shall be drawn naming the State Treasurer, State of New Jersey as beneficiary issued by a Federally insured financial institution.**

(b) **Failure to submit the required performance security may be sufficient cause for the Director to cancel the contract and assess the contractor for any costs incurred by the State.**

17:12-2.4 Information in bidding

(a) (No change.)

(b) **The Director may make a stipulated award to a bidder when deemed to be in the best interest of the State, considering terms, conditions, specifications and cost. However, in no case shall the stipulated award be used to correct a deficient bid proposal.**

17:12-2.5 Cause for automatic rejection of bids

(a) Pursuant to N.J.S.A. 52:34-12, the State Treasurer has determined that it is in the public interest to establish grounds for automatic rejection of bids which fail to conform with the requirements of the request for proposal in the following respects:

1. No signature in the bid document: If the vendor has not affixed his signature anywhere in the bid document, that is, on any of the documents he returns in response to a request for proposal. Signature on an enclosed bid deposit check (where security is required) will not suffice, since bid security is not considered part of the bid document. **Signatures on the Stockholders Disclosure Form and the Affirmative Action Affidavit do not constitute a bid signature;**
2. Bid not received on or before the time and date, **and at the place specified on the bid request form;**
3. (No change.)
4. Failure to provide bid security when it is required **and in the amount specified in the bid;**
5. (No change.)
6. Failure to initial price alterations: If a unit price in the bid has been altered, the vendor's initials must appear adjacent to the alteration. Examples of alterations include, but are not limited to, crossouts [and], erasures, etc., with reentered prices. If the alteration has not been so initialed, that particular item only in the bid will be automatically rejected, except as follows: If the extended price is correct and does not contain alterations, it shall be considered the bid price. If the extended total price does not contain alterations and the altered unit price is not initialed, the extended total price is considered as the bid price. In the event of an automatic rejection, and when the bid contains multiple items, the remainder of the bid will be evaluated;
- 7-8. (No change.)
9. **Telephone, telefacsimile or telegraph bids will not be accepted for publicly advertised bid requirements which specify sealed bid submissions.**

17:12-2.7 Bid errors

(a)-(d) (No change.)

(e) **If a pricing error is discovered after bid opening between the unit price and the total extended price, the unit price shall prevail.**

[(e)] (f) (No change in text.)

17:12-2.8 Bid openings

(a)-(b) (No change.)

(c) **If a bid is received by the Purchase Bureau prior to the time and date of the bid opening, but through error has not been opened and read publicly at the specified time, date and place, the Director shall notify all bidders and schedule a bid opening date, time and place for that bid or bids only.**

## 7:12-2.9 Response to bid invitation; result of failure

If a bidder does not respond to three consecutive [bids] opportunities to bid for the same product or service, the Director may remove [him] the bidder from the bidder's list for that product or service. [All vendors will be notified after the second consecutive failure to respond, that failure to respond on the next bid will result in their removal from the list.]

## 7:12-3.3 Request for hearings; hearing procedures; time limitations

(a) Any [vendor or] interested bidder requesting a hearing:

1. Must make written request to the Director, Division of Purchase and Property setting forth the specific grounds for challenging the award. The notice must be submitted within 10 working days after receipt of written notification that his bid has not been accepted or that an award of the contract has been made. If no written notice of award is provided, the request for hearing must be made within a reasonable time.

2. Hearings which are not under the jurisdiction of the Office of Administrative Law shall be informal and held, where feasible, within 4 days. Hearings will be heard, where practicable, by an impartial hearing officer. The hearing officer shall prepare a report to the Director within 10 days of the conclusion of the hearing unless, due to the circumstances of the hearing, a greater time is required. The hearing report shall be advisory in nature and is not binding on the Director. All parties shall receive a copy of the hearing officer's report and have 10 days to provide written comments or exceptions to the Director. Subsequent to the 10 day period for exceptions, the Director, Division of Purchase and Property, shall make a final judgment on the matter:

i. Such informal hearings as convened under these rules are fact finding for the benefit of the Director. The Director may determine that sufficient information already exists in the record so that a decision can be made without an informal hearing. The Director may waive the informal hearing and publish a final decision accordingly.

3.-4. (No change.)

## 7:12-3.4 Necessary parties to the hearing

(a) In those instances where a hearing is requested by [a vendor or] an interested bidder, the Director, Division of Purchase and Property, shall extend invitations to all interested vendors who bid on the matter in question. The extent of the participation of these parties shall be limited to those matters in question as expressed by the complaining parties. The Director, Division of Purchase and Property, has discretionary authority to exclude invitations to bidders in those cases where such bidders have no potential interest in the outcome of the hearing.

(b)-(c) (No change.)

## 17:12-5.1 Subscription fees

(a) The Director, Division of Purchase and Property, may establish a subscription fee for the dissemination of State contract and specification information to the local governments, **volunteer fire departments and volunteer first aid or rescue squads**, school districts, **county colleges, State colleges, quasi-State agencies and independent authorities** and independent institutions of higher education of this State. That fee shall be chargeable on an annual basis, and shall be structured to include direct State costs of personnel, printing and mailing of notices of award and other procurement information to the local governments, **volunteer fire departments and volunteer first aid or rescue squads**, school districts, **county colleges, State colleges, quasi-State agencies and independent authorities** and independent institutions of higher education.

AGENCY NOTE: N.J.A.C. 17:12-6 is recodified as N.J.A.C. 7:13.

## SUBCHAPTER [7] 6. DEBARMENT, SUSPENSION AND DISQUALIFICATION OF A PERSON(S)

## 17:12-7.2 Causes for debarment of a person(s)

(a) In the public interest, Division of Purchase and Property shall debar a person for any of the following causes:

1.-13. (No change.)

14. Any offer or agreement to pay or to make payment either directly or indirectly, any fee, commission, compensation, gift, gratuity, or other thing of value of any kind to any State officer or employee or special State officer or employee, as defined by N.J.S.A. 52:13D-13b and e, in the Department of the Treasury or any other agency with which such vendor transacts or offers or proposes to transact business, or to any member of the immediate family as defined by N.J.S.A. 52:13D-13i, of any such officer or employee, or any partnership, firm, or corporation with which they are employed or associated, or in which such officer or employee has an interest within the meaning of N.J.S.A. 52:13D-13g;

15. Failure by a vendor to report to the Attorney General and to the Executive Commission on Ethical Standards in writing forthwith the solicitation of any fee, commission, compensation, gift, gratuity or other thing of value by any State officer or employee or special State officer or employee;

16. Failure by a vendor to report in writing forthwith or failure to obtain a waiver from the Executive Commission on Ethical Standards, who may undertake, directly or indirectly, any private business, commercial or entrepreneurial relationship with, whether or not pursuant to employment, contract or other agreement, express or implied, or sell any interest in such vendor to, any State officer or employee or special State officer or employee having any duties or responsibilities in connection with the purchase, acquisition or sale of any property or services by or to any State agency or any instrumentality thereof, or with any person, firm or entity with which he is employed or associated or in which he has an interest within the meaning of N.J.S.A. 52:13D-13g;

17. Influence or attempt to influence or cause to be influenced, any State officer or employee or special State officer or employee in his official capacity in any manner which might tend to impair the objectivity or independence of judgment of said officer or employee;

18. Cause or influence or attempt to cause or influence, any State officer or employee or special State officer or employee to use, or attempt to use, his official position to secure unwarranted privileges or advantages for the vendor or any other person.

## CHAPTER 13

## GOODS AND SERVICES CONTRACTS FOR SMALL BUSINESSES, URBAN DEVELOPMENT ENTERPRISES AND MICRO BUSINESSES

## SUBCHAPTER [6.] 1. GOODS AND SERVICES CONTRACTS FOR SMALL BUSINESSES, [FEMALE AND MINORITY BUSINESSES] URBAN DEVELOPMENT ENTERPRISES AND MICRO BUSINESSES

## 17:[12-6.1]13-1.1 Applicability and scope

(a) The rules in this [subchapter] chapter are jointly promulgated by the Department of Commerce, Energy and Economic Development (hereinafter, "Department of Commerce") and the Department of Treasury to implement the Small Business Set-Aside Act, P.L. 1983, c.482, as amended and renamed the Set-Aside Act for Small Businesses, Female Businesses and Minority Businesses, P.L. 1985, c.384, N.J.S.A. 52:32-17 et seq. [The Act establishes a goal of awarding no less than 25 percent of State agency contracts to small businesses, female-owned businesses and minority owned businesses. Specifically, the Act sets goals of 15 percent of State contracts for small businesses, seven percent of State contracts for minority businesses and three percent of State contracts for female businesses.] **These rules establish goals of 15 percent of State contracts for small business, seven percent of State contracts for urban development enterprise and three percent of State contracts for micro business, exclusive of those contracts governed by N.J.S.A. 17:14-1 et seq.**

(b) [The Act] **These rules** require[s] the Department of Commerce to establish and implement standards and procedures for registering vendors as small business[es], [minority and female businesses] **urban development enterprise and micro business**. [The Act] **These rules** require[s] the Department of Treasury to establish contracting and purchasing procedures for implementing the goals of [the Act] **these rules**.

(c) These rules are divided into two major parts. The first part, N.J.A.C. 17:[12-6.3]13-1.3 to N.J.A.C. 17:[12-6.8]13-1.8, describes the procedures for businesses to qualify under [the Act] **these rules** and the penalties for filing false information under [the Act] **these rules**. The second part, N.J.A.C. 17:[12-6.9]13-1.9 to N.J.A.C. 17:[12-6.16]13-1.16, describe the procedures for State agencies to implement [the Act] **these rules**.

(d) Applications and questions regarding eligibility as a small business, [minority and/or female business] **urban development enterprise and/or micro business** should be addressed to:

[Certification and Approvals Unit  
Department of Commerce  
1 West State Street  
CN 823

Trenton, New Jersey 08625]

[Questions concerning eligibility under the Act of small businesses should be directed to:]

[Office of Small Business Assistance]  
**Division of Development for Small Businesses  
and Women and Minority Businesses**

Department of Commerce, **Energy and Economic Development**  
[1] 20 West State Street  
CN [823] 835

Trenton, New Jersey 08625

[Questions concerning eligibility under the Act of minority businesses should be directed to:

Office of Minority Business Enterprise  
Department of Commerce  
1 West State Street  
CN 823

Trenton, New Jersey 08625]

[Questions concerning eligibility under the Act of female businesses should be directed to:

Office of Women Business Enterprise  
Department of Commerce  
1 West State Street  
CN 823

Trenton, New Jersey 08625]

Questions concerning the award of contracts under [the Act] **these rules** should be directed to:

Department of the Treasury  
General Services Administration  
Division of Purchase and Property  
Attention: Purchase Bureau  
135 W. Hanover St.  
CN 230

Trenton, New Jersey 08625

(e) [The Act applies] **These rules apply** to every State agency with purchasing authority or contracting authority. The rules in this [subchapter] **chapter** apply to all contracts for the purchase of goods and services which are awarded by the State's various contracting agencies. The State contracting agencies whose purchases are governed by these rules include the following **except where expressly inconsistent with statutory law**:

1. DEPARTMENTS:

- Agriculture
- Banking
- Personnel
- Commerce, **Energy** and Economic Development
- Community Affairs
- Corrections
- [Defense]
- Education
- [Energy]
- Environmental Protection
- Health
- Higher Education
- Human Services
- Insurance
- Labor
- Law and Public Safety

**Military and Veterans Affairs**

Public Advocate

State

Transportation

Treasury

2-4. (No change.)

17:[12-6.2]13-1.2 Definitions

(a) The words and terms used in this [subchapter] **chapter** shall have the following meanings unless the context clearly indicates otherwise.

...  
"Cooperative purchasing" means an award made by the Division of Purchase and Property for the use of either local governing authorities, pursuant to N.J.S.A. 52:25-16.1 et seq., **volunteer fire departments, volunteer first aid squads and rescue squads, pursuant to N.J.S.A. 52:25-16.2, county colleges, pursuant to N.J.S.A. 18A:64A-25.9(b), State colleges, pursuant to N.J.S.A. 18A:64-60**, or quasi-State agencies, pursuant to N.J.S.A. 52:27B-56.1. Such an award is made as an adjunct to an award of a contract for State agency purchases.

"Delegated Purchase Authority" means[: ] [1. The] **the** authority of a State agency to award contracts on its own pursuant to authority delegated by the Director, Division of Purchase and Property. (See N.J.S.A. 52:25-23.)

[2. The authority of a State agency to award contracts on its own pursuant to authority delegated by the Director, Division of Building and Construction. (See N.J.S.A. 52:18A-78.11.)]

"Direct purchasing" means the issuance of a purchase order by a State agency for a specific item of goods or service, for which a contract either has already been awarded or is simultaneously being awarded. The [terms] **term** is generally applied when a State agency issues a purchase order for goods or services available under either a contract awarded by the State agency pursuant to its own statutory contracting authority, a term contract awarded by the Division of Purchase and Property, or a line-item contract awarded by the State agency pursuant to purchasing authority delegated from the Division of Purchase and Property. (For line-item contracts awarded by the Division of Purchase and Property, a purchase order is issued by the Division of Purchase and Property.)

["Division of Building and Construction" means the State agency within the Department of Treasury which provides a centralized contracting service for other State agencies, pursuant to N.J.S.A. 52:18A-151, 162.]

...  
["Multiple award] **Multi source** contract" means a term contract awarded by the Division of Purchase and Property or other contracting agency wherein more than one vendor is awarded a contract. The term is applicable in two situations, when defined in conjunction with the Division of Purchase and Property (see N.J.S.A. 52:34-12.1):

1. Where the volume of business is so large or the geographical distances are so great that more than one vendor is necessary to serve the State's needs; or

2. Where the differences between various vendors' versions of a product are so significant that it is useful to have a contract with a vendor of each product.

...  
"Request for Proposals" or "RFP" means the document issued by the Purchase Bureau of the Division of Purchase and Property[; Division of Building and Construction] or any other contracting agency which forms the basis of an advertised bidding and award process conducted by the contracting agency. The RFP defines the contract's basic terms and conditions, the specifications, and other requirements, such as a set-aside requirement (restricting the bidding to businesses qualified as small **business**, [minority or female businesses] **urban development enterprise or micro business**). RFP's are usually of two types, those for term contracts and those for line-item contracts.

"Set-aside contract" means a contract [or subcontract] specifically designated by a contracting agency as being for small business[es, minority and/or female businesses] **urban development enterprise and/or micro business**.

"Term contract" means an award made by a contracting agency in which a source of supply for a product is established for a specific period of time. A term contract is generally applied when a State agency:

1. Establishes a fixed, unit price or discount for items to be purchased thereunder;
2. Provides for some estimated dollar volume or minimum quantities to be purchased; or
3. Provides for the rebidding of any single purchase which exceeds specified maximum amount.

"Using agency" means the State agency for which a contract or purchase of goods or services is being made.

["Vendors with the Division of Building and Construction" means construction contractors, architects, engineers, professionals, and all other vendors for which DBC contracts.]

"Waiver" means an award process authorized by N.J.S.A. 52:34-8] 9 and 52:34-10, which does not require public advertisement and which is approved by the State Treasurer. Whenever possible competition is sought prior to issuance of a waiver of advertising.

7:[12-6.3]13-1.3 Standards of eligibility for small [business] businesses, [minority and female businesses] urban development enterprises and micro businesses

(a) A business may be eligible as a small business, [a minority business, a female business] an urban development enterprise, a micro business, or [any] a combination of the three.

(b) In order to be eligible [under the Act] as a small business, minority business or female business, a business must [both have its principal place of business in New Jersey and] be independently owned and operated.

1. For purposes of these rules, a business shall be deemed [to have its principal place of business in New Jersey:] to be independently owned and operated if its management is responsible for both its daily and long term operation, and if its management owns at least 51 percent interest in the business.

(c) In order to be eligible as a small business, a business must have its principal place of business in New Jersey.

1. For purposes of these rules, a business shall be deemed to have its principal place of business in New Jersey:

- i. When it has been either incorporated or registered to do business in New Jersey; and
- ii. When either 51 percent or more of its employees work in New Jersey, as evidenced by the payment of New Jersey unemployment taxes, or 51 percent or more of its business activities take place in New Jersey, as evidenced by its payment of income or business taxes.

[2. For purposes of these rules, a business shall be deemed independently owned and operated, if its management is responsible for both its daily and its long term operation, and if its management owns at least 51 percent interest in the business.]

[(c)](d) In order to be eligible as a small business, a business must be a sole proprietorship, partnership or corporation with 100 or fewer employees in full-time positions.

1. In determining its number of full-time employees, a business shall not include:

- i. Seasonal and part-time employees employed for less than 90 days, if seasonal and casual part-time employment are common to that industry; and
- ii. Consultants employed under other contracts not related to the goods or services which are the subject of the specific contract the business wants to be eligible as a small business.

[(d)] In order to be eligible as a minority business, a business must be a sole proprietorship, partnership or corporation at least 51 percent of which is owned and controlled by persons who are Black, Hispanic, Portuguese, Asian American, American Indian or Alaskan natives, which are defined as follows:

1. Black American: having origins in any of the black racial groups of Africa.
2. Hispanic American: a person of Mexican, Puerto Rican, Cuban, Central or South American or other Spanish culture or origin, regardless of race.

3. Asian American: a person having origins in any of the original people of the Far East, Southeast Asia, and Indian subcontinent, Hawaii or the Pacific Islands.

4. American Indian or Alaskan native: a person having origins in any of the original peoples of North America and who maintains cultural identification through tribal affiliation or community recognition.

5. Portuguese: a person of Portuguese, Brazilian, or other Portuguese culture or origin, regardless of race.

(e) In order to be eligible as a female business, a business must be a sole proprietorship, partnership or corporation at least 51 percent of which is owned and controlled by women.]

(e) In order to be eligible as an urban development enterprise (UDE), a business must be independently owned and operated.

1. For purposes of these rules, a business shall be deemed to be independently owned and operated if its management is responsible for both its daily and long term operation, and if its management owns at least 51 percent interest in the business.

(f) In order to be eligible as an urban development enterprise, a business must have its principal place of business in a municipality designated as being qualified under the New Jersey Urban Development Corporation Act pursuant to N.J.S.A. 55:19-3(f).

1. For purposes of these rules, a business shall be deemed to have its principal place of business in a municipality designated as qualified under the New Jersey Urban Development Corporation Act:

- i. When its incorporation or registration papers or latest New Jersey State Income Tax Form indicates a postal zip code assigned to a UDC qualified municipality; and
- ii. When either 51 percent or more of its employees work in a UDC qualified municipality as evidenced by the payment of unemployment taxes, or 51 percent or more of its business activities take place in a UDC qualified municipality as evidenced by its payment of business taxes.

(g) In order to be eligible as an urban development enterprise, a business must be a sole proprietorship, partnership or corporation with 50 or fewer employees in full-time positions.

1. In determining its number of full-time employees, a business shall not include:

- i. Seasonal and part-time employees employed for less than 90 days, if seasonal and casual part-time employment are common to that industry; and
- ii. Consultants employed under other contracts not related to the goods or services which are the subject of the specific contract the business wants to be eligible as an urban development enterprise.

(h) In order to be eligible as a micro business, a business must be independently owned and operated.

1. For purposes of these rules, a business shall be deemed to be independently owned and operated if its management is responsible for both its daily and long term operation, and if its management owns at least 51 percent interest in the business.

(i) In order to be eligible as a micro business, a business must be a sole proprietorship, partnership or corporation with 20 or fewer employees in full-time positions.

1. In determining its number of full-time employees, a business shall not include:

- i. Seasonal and part-time employees employed for less than 90 days, if seasonal and casual part-time employment are common to that industry; and
- ii. Consultants employed under other contracts not related to the goods or services which are the subject of the specific contract the business wants to be eligible as a micro business.

17:[12-6.4]13-1.4 Registration procedures for small businesses, [minority businesses and female businesses] urban development enterprises and micro businesses

(a) Any business which seeks to register under [the Act] these rules as a small business, [minority business and or female business] urban development enterprise and/or micro business must apply to the Department of Commerce. For these purposes, the Department of Commerce shall prepare a Vendor Registration Form. This form shall be available from the Department of Commerce, the Division of Purchase and Property and the State's other contracting agencies.

(b) As part of its application to the Department of Commerce, a business shall reasonably document its principal place of business and independent status, and, as appropriate, the number of its employees [and the character of its ownership]. Where available, this documentation should include appropriate forms or reports otherwise submitted to or issued by State and Federal agencies, such as [employee or affirmative action reports filed with the New Jersey Department of Labor or] certificates of incorporation issued by the New Jersey Department of State.

1. If an applicant fails to complete fully the Vendor Registration Form or to document its application, the application may be delayed or rejected.

2. If an applicant knowingly supplies incomplete or inaccurate information, the applicant shall be disqualified under these rules and may be subject to other penalties described in N.J.A.C. 17:[12-6.8] 13-1.8.

(c) In order to be registered under [the Act] **these rules**, a business must also comply with any pre-approvals or other eligibility requirements legitimately established by the contracting agency for whose contracts the business intends to bid.

17:[12-6.5]13-1.5 Acceptance as a small business, [minority or female business] **urban development enterprise or micro business**

(a) **When a business is accepted as a small business, urban development enterprise and/or micro business, that business may bid on RFPs which are specifically set aside under these rules.**

[(a)](b) When a business is accepted by the Department of Commerce as a small business, [minority business or female business] **urban development enterprise or micro business**, the business will be added by the Department of Commerce onto the set-aside vendors lists. **These lists [which] shall be used in determining whether the contracting agencies have fulfilled their contracting goals under [the Act,] these rules and shall be used by contracting agencies in soliciting bids or contracts set aside for small business[es, minority and/or female businesses] urban development enterprise and/or micro business and other purchasing and contracting situations.** (See N.J.A.C. 17:[12-6.9]13-1.9 and 17:[12-6.12]13-1.12) There will be no limits to the number of businesses on the various Small Business, [Minority Business and Female Business] **Urban Development Enterprise and Micro Business** bidders list. Each eligible applicant will be placed on that list or those lists for which it is qualified.

[(b) When a business is accepted as a small business, minority business and/or female business, that business may bid on RFPs which are specifically set aside under the Set-Aside Act.]

17:[12-6.6]13-1.6 Time for application to register as a small business, [minority business or female business] **urban development enterprise or micro business**

(a) A business may apply to the Department of Commerce at any time to be registered under [the Set-Aside Act] **these rules** as a small business, [minority business or female business] **urban development enterprise or micro business** and to be placed on appropriate set-aside vendors lists.

(b) Where a contract has been specifically set aside under [the Act] **these rules** for small business[es], [minority business and/or female business] **urban development enterprise and/or micro business**, a business may apply to the Department of Commerce for purposes of registration as a set-aside business so as[,] to bid on that specific contract no later than the bid opening date for that contract, and shall include the name of the contracting agency, the RFP number and the bid opening date along with its application to the Department of Commerce.

17:[12-6.7]13-1.7 Procedures for challenging a business registered as a small business, [minority business or female business] **urban development enterprise or micro business**

(a) The qualification under these rules of a business on a bidders list as a small business, [minority business or female business] **urban development enterprise or micro business** may be challenged by any other business on the State bidders list or any of the State departments or agencies covered under [the Act] **these rules**. The qualifi-

cation of a business to bid on a contract set aside for small **business**, [minority and/or female businesses] **urban development enterprise and/or micro business** may be challenged by any other bidder [on] for the contract on the State bidders list.

1. A registration challenge shall be made in writing to the Department of Commerce with copies to the challenged business and to the appropriate contracting agency [where] when a specific contract is at issue.

2. A registration challenge to the Department of Commerce may concern only the qualification of a business under these rules as a small business, [minority business or female business] **urban development enterprise or micro business**. Any challenge to a business' qualifications to perform a contract shall be referred to the appropriate contracting agency.

3. The written challenge shall be accompanied and supported by documentation in support of its charges.

(b) In the case of a challenge to a bidder on a set-aside contract, except where emergent circumstances disclosed to the Department of Commerce and the bidders require the immediate implementation of an award, the State **contracting agency** making the award shall be notified and shall withhold the final award of the set-aside contract for 10 days from the date of the issuance of any intent to award or proposed award, so that the Department may conduct a hearing if warranted.

1.-3. (No change.)

4. The right to challenge a bidder's registration under these rules is in addition to any protest hearing rights which are afforded by a contracting agency, such as those provided by the Division of Purchase and Property in N.J.A.C. 17:12-3 [and the Division of Building and Construction in N.J.A.C. 17:19-2].

(c) (No change.)

17:[12-6.8]13-1.8 Obligation to provide information and penalties for failure to provide complete and accurate information

(a) Applicants under these rules shall accurately and honestly supply all information required by the Department of Commerce.

(b) When a business has been approved as an eligible small business, [minority business or female business] **urban development enterprise or micro business** on the basis of false information knowingly supplied by the business and the business has been awarded a set-aside contract, the Commissioner of the Department of Commerce, after notice and opportunity for a contested case hearing pursuant to N.J.S.A. 52:14B-10 and N.J.A.C. 1:1, may:

1.-3. (No change.)

(c) Any business approved by the Department of Commerce as a small business, [minority business and/or female business] **urban development enterprise and/or micro business** shall immediately apprise the Department of any circumstances which might disqualify the participation of the business under these rules.

(d) The failure of a business to report any such changed circumstances, or the intentional reporting of false information, shall disqualify the business for inclusion on any bidders list under these rules and may subject the business to adverse action by the contracting [agencies] **agency**. (See N.J.A.C. 17:12-[2(e)]7.5 and N.J.A.C. 17:12-7.2)

17:[12-6.9]13-1.9 Purchase goals

(a) [N.J.S.A. 52:32-17] **These rules** establish[es] goals for contracting [agency] **agencies** of awarding 15 percent of [its] **their** contracts to small business[es], seven percent of its contracts to minority businesses and three percent of its contracts to female businesses], **seven percent of their contracts to urban development enterprise and three percent of their contracts to micro business**.

(b) In determining compliance with the goals, an agency may consider only businesses duly approved by the Department of Commerce as small business[es], minority businesses and female businesses], **urban development enterprise and micro business**.

(c) In determining compliance with the goals, the Division of Purchase and Property, and any other contracting agency whose primary function is to award contracts for use by other agencies, may consider the total number of contracts it has awarded and the number

t has awarded to small **business**, [minority and female businesses] **urban development enterprise and micro business**. For those purposes, t may count the number of [term contract it has awarded] **awards made under term contracts**, in addition to the number of line-item contracts it has awarded[. In so doing, the Division and other similarly situated contracting agencies may also consider each award under a multiple award contract as a separate contract. Therefore, in computing the total number of contracts awarded by the Division or other contracting agency, the agency may count each separate line-item contract, each award of a multiple award contract and each other term contract. Notwithstanding], **notwithstanding** the dollar amounts of the contracts, and the number of purchase orders issued by using agencies under the contracts.

(d) In determining compliance with the goals, other contracting agencies, using agencies issuing purchase orders under contracts otherwise awarded and agencies awarding contracts under delegated purchasing authority shall consider separately the number and the dollar amount of purchase orders issued. In setting its goals, the agency shall compute the total number of purchase orders issued and the total dollar amount expended by the agency through purchase orders. The agency shall attempt both to issue the appropriate percentage of purchase orders to businesses approved under these rules and to spend an appropriate percentage of money on these purchases.

(e) In determining the purchase goals, an agency shall not include any contract or purchase for which the application of the set-aside preferences, in-state preferences or other procedures established by [the Act] **these rules** would jeopardize the State's participation in a program from which the State receives Federal funds or other benefits.

(f) Where an agency is otherwise unable to fulfill the goals under [the Act] **these rules**, the agency shall make a good faith effort to achieve its goals through specifically setting aside contracts and purchases for small business[es, minority businesses and/or female businesses], **urban development enterprise and/or micro business**. A set-aside contract must be competitively awarded and may be awarded only after the receipt of bids from three qualified bidders.

(g) In determining compliance with the goals, the award of a contract or purchase order may be counted toward only one goal. For example, the award of a contract to a small business [owned by a black woman] **located in a municipality designated as being qualified under the New Jersey Urban Development Corporation Act and having no more than 20 full-time employees** may be counted toward either the small business goal, [minority business goal or female business goal] **urban development enterprise goal or micro business goal**, but not towards more than one goal.

#### 17:[12-6.10]13-1.10 Set-aside plans

(a) On or before [June] **August 1** of each year, each contracting agency and using agency shall prepare and submit to the Department of Commerce a set-aside plan for meeting the purchase goals for the [next] **current** fiscal year.

(b) The set-aside plan shall include:

1. A general list and explanation of the goods and services and/or types of goods and services which are deemed appropriate for meeting the purchasing goals;

2. A consideration of the estimated dollar amounts and numbers of purchase orders expected for various contracts and types of contracts;

3. A list of those contracts and/or purchase orders it expects to award to small business[es, minority businesses and female businesses], **urban development enterprise and micro business**, [including] **identifying** those contracts it intends to set aside.

(c) After consultation with the Department of Commerce, the contracting agency or using agency shall begin implementing the [next] **current** year's set-aside plan no later than [July] **October 1**. However:

1. The agency and the Department shall periodically review the plan's implementation and shall develop any revisions which may be necessary to achieve the goals; and

2. Where the agency and the Department disagree about the agency's plan or its implementation, the matter shall be submitted immediately for prompt resolution by the Commissioner of the Depart-

ment of Commerce, **Energy** and Economic Development and the State Treasurer, or their designees.

#### 17:[12-6.11]13-1.11 Factors in establishing purchasing plans

(a) The following factors are to be considered by contracting and using agencies in determining whether a contract or purchase is appropriate for meeting the agencies' goals [if the contract is in an area wherein]:

1. Small business[es, female or minority businesses], **urban development enterprise or micro business** do not currently obtain a significant percentage of State contracts, but wherein the price, quality of product and responsibility of small business[es, female businesses or minority businesses], **urban development enterprise or micro business** are competitive with the general business community; or

2. The normal bidding process creates unnecessary obstacles against small business[es, female and minority], **urban development enterprise and micro business** irrespective of any actual ability of these businesses to perform the contracts or fulfill the State's needs; or

3. Small business[es, female and minority businesses], **urban development enterprise and micro business** are not competitive with the general business community, but wherein the State would not suffer any disadvantage if a percentage of contracts and purchases were awarded to those businesses; or

4. The State's long term best interests in purchasing lie in developing small business[es, female and minority], **urban development enterprise and micro business** in competition with the general business community; or

5. The State's long term best **economic and social** interests [economically and socially] lie in developing small business[es, female and minority businesses], **urban development enterprise and micro business**; or

6. The practices of the contracting or using agency create unnecessary obstacles to the award of contracts to small business[es, female and minority businesses], **urban development enterprise and micro business**; or

7. Potential emergency conditions, public health and safety considerations, or the continued operation of vital State services, preclude setting the contract aside for bidding exclusively by small business[es, female or minority business], **urban development enterprise and micro business**.

#### 17:[12-6.12]13-1.12 Bidders lists

(a) With the cooperation and coordination of the Department of Commerce, contracting agencies and using agencies shall maintain lists of small business bidders, [minority business bidders and female business bidders] **urban development enterprise bidders and micro business bidders**.

(b) (No change.)

(c) On or about October 1 of each year, each contracting agency and using agency maintaining small **business**, [female and/or minority business] **urban development enterprise and/or micro business** vendors lists shall submit such lists for review and approval to the Department of Commerce. The Department shall respond by December 15.

1. Unless and until disapproved by the Department, a State agency may continue to use any existing small **business**, [female and minority business] **urban development enterprise and micro business** bidders lists.

2. Unless and until disapproved by the Department, the State agency may continue to count towards its purchasing goals contracts awarded to any business previously approved for inclusion on a designated bidders list.

3. Where a contract is specifically set aside for small **business**, [female and/or minority businesses] **urban development enterprise and/or micro business**, and where no approved list is available from the Department, an agency may issue RFPs or other solicitations to businesses on any otherwise appropriate list of bidders so long as the RFPs and solicitations specify that only approved small **business**, [female-owned and/or minority-owned businesses] **urban development enterprise and micro business**, as appropriate, may bid on the contract. The agency shall also include a New Jersey Vendor Registration Form with the RFP or other solicitation and shall include instruc-

tions on how to apply to the Department of Commerce for appropriate approval.

(d) (No change.)

17:[12-6.13]13-1.13 Set-aside contracts

(a) Any contract specifically set aside for small business, [minority and/or female businesses] **urban development enterprise and micro business** must be competitively bid, either through public advertising or through informal bidding, and may be awarded only if responsive bids from at least three qualified bidders are received.

(b) The RFP for a set-aside contract shall clearly and conspicuously state that an award may go only to a business duly approved by the Department of Commerce.

1. The RFP shall further state that a bidder who is not already approved, may submit a bid but then must apply to the Department of Commerce for approval as a small business, [minority or female business] **urban development enterprise or micro business**, as appropriate, no later than the bid opening date and, in order to be eligible for an award under that RFP, must be approved by the Department no later than five working days after the bid opening date. The RFP shall state that if for whatever reason, the contracting agency does not receive approval of that bidder from the Department of Commerce no later than five working days from the bid opening date, the agency shall reject that bid without any obligation or recourse to the bidder.

(c) All bids may be rejected on a set-aside contract and the contract may be rebid as an ordinary contract where:

1. In evaluating the small business, [female and/or minority business] **urban development enterprise and/or micro business** bids, the agency determines that acceptance of any of the bids would subject the State to an unreasonable expense, or to a contract otherwise unacceptable pursuant to that agency's contracting and purchasing laws and rules; or

2. The agency does not receive at least three bids from qualified vendors approved as small business, [female and/or minority businesses] **urban development enterprise and/or micro business**, as appropriate; and

3. The agency notifies the bidders and the Department of Commerce of the reasons for its action, and the agency maintains its records of the bidding process for seven years from the bid opening date.

(d) Immediately after rejecting all bids, the agency may, without any delay, rebid the contract as an ordinary award. Small business, [female and minority businesses] **urban development enterprise and micro business** bidders may participate in this rebidding process.

17:[12-6.14]13-1.14 Purchasing and contracting reports

(a) (No change.)

(b) The report shall include:

1. The total number of contracts awarded and/or purchase orders issued by the contracting or using agency.

2. The estimated total dollar amounts of contracts and/or purchase orders awarded by the contracting or using agency.

3. The number of set-aside contracts and/or purchase orders awarded by the contracting agency and by its using agencies.

4. The estimated dollar amounts of contracts and/or purchase orders awarded to small business, [minority and female businesses] **urban development enterprise and micro business** by the contracting or using agency.

5. A breakdown of the types of contracts and/or purchase orders awarded generally and awarded to small business, [minority and female businesses] **urban development enterprise and micro business** by the contracting or using agency.

6. An analysis of whether and how the previous year's goals were achieved by the contracting or using agency.

17:[12-6.15]13-1.15 Consultation with industry

(a) The Department of Commerce shall conduct no less than two consultation sessions each year with bidders, vendors and industry representatives for the purpose of soliciting information and suggestions on implementing the [various] goals in [the Act and] these rules.

(b) The consultation dates and times will be incorporated into a plan developed by the Department for each fiscal year.

(c) Bidders, vendors and industry representatives may call the [Office of Small Business Assistance] **Division of Development for Small Business and Women and Minority Businesses** [or, in the case of a minority business, the Office of Minority Business Enterprise or in the case of a woman business the Office of Women Business Enterprise,] for the exact time, date and location of these sessions.

(d)-(g) (No change.)

(h) Notice that the sessions have been held will be included in the annual reports of Departments on the implementation of [the Set-Aside Act for Small Businesses, Female Businesses, and Minority Businesses] **these rules for small business, urban development enterprise and micro business**.

17:[12-6.16]13-1.16 Delegation of Treasurer's authority

For purposes of implementing [the Set-Aside Act for Small Business, Female Businesses and Minority Businesses] **these rules**, the authority of the Treasurer under [the Act] **these rules** is delegated to the Administrator of the General Services Administration.

CHAPTER 14

MINORITY AND FEMALE SUBCONTRACTOR PARTICIPATION IN STATE CONSTRUCTION CONTRACTS

SUBCHAPTER 1. MINORITY AND FEMALE SUBCONTRACTOR PARTICIPATION IN STATE CONSTRUCTION CONTRACTS

17:14-1.1 Definitions

The following words and terms, when used in this subchapter, shall have the following meanings unless the context clearly indicates otherwise.

"Commissioner" means the Commissioner of the Department of Commerce, Energy and Economic Development or his or her designee.

"Construction contract" means any contract to which the State or any State contracting agency is a party involving any construction, renovation, reconstruction, rehabilitation, alteration, conversion, extension, demolition, repair or other changes or improvements of any kind whatsoever of any public structure or facility. The term also includes the supervision, inspection and other on-site functions incidental to actual construction.

"Contractor" means any party performing or offering to perform a prime contract and any supplier of materials or goods used to perform a construction contract with the State of New Jersey or any board, commission, committee, authority or agency of the State.

"Division of Building and Construction" means the State agency within the Department of Treasury which provides a centralized purchasing service for other State agencies pursuant to N.J.S.A. 52:18A-151 and 162.

"Female business" means a business which is a sole proprietorship, partnership or corporation at least 51 percent of which is owned and controlled by women.

"Minority business" means a business which is a sole proprietorship, partnership or corporation at least 51 percent of which is owned by persons who are Black, Hispanic, Portuguese, Asian American, American Indian or Alaskan natives, defined as follows:

1. Black American: having origins in any of the black racial groups of Africa.

2. Hispanic American: a person of Mexican, Puerto Rican, Cuban, Central or South American or other Spanish culture or origin, regardless of race.

3. Asian American: a person having origins in any of the original people of the Far East, southeast Asia, and Indian subcontinent, Hawaii or the Pacific Islands.

4. American Indian or Alaskan native: a person having origins in any of the original peoples of North America and who maintains cultural identification through tribal affiliation or community recognition.

5. Portuguese: a person of Portuguese, Brazilian, or other Portuguese culture or origin, regardless of race.

"State contracting agency" means any board, commission, committee, authority or agency of the State which possesses the legal authority to award and make contracts and includes the following except where expressly inconsistent with statutory authority:

1. DEPARTMENTS:

- Agriculture
- Banking
- Personnel
- Commerce, Energy and Economic Development
- Community Affairs
- Corrections
- Military and Veterans Affairs
- Education
- Environmental Protection
- Health
- Higher Education
- Human Services
- Insurance
- Labor
- Law and Public Safety
- Public Advocate
- State
- Transportation
- Treasury

2. COLLEGES:

- Edison College
- Glassboro State College
- Jersey City State College
- Kean College
- Montclair State College
- N.J. Institute of Technology
- Ramapo College
- Rutgers University
- Stockton State College
- Trenton State College
- University of Medicine and Dentistry
- William Paterson College

3. AUTHORITIES:

- Board of Public Utilities
- Casino Redevelopment Authority
- Development Authority for Small Businesses, Minorities and Women's Enterprises
- Expressway Authority
- Health Care Facilities Financing Authority
- Highway Authority
- N.J. Economic Development Authority
- N.J. Educational Facilities Authority
- N.J. Health Care Facilities Financing Authority
- N.J. Housing & Mortgage Finance Agency
- N.J. Transit Corp.
- N.J. Water Supply Authority
- Public Broadcasting Authority
- Sports and Exposition Authority
- Turnpike Authority
- Urban Development Corporation

4. COMMISSIONS

- Beach Erosion Commission
- Casino Control Commission
- County and Municipal Government Study Commission
- Election Law Enforcement Commission
- Executive Commission on Ethical Standards
- Hackensack Meadowlands Development Commission
- N.J. Commission on Capital Budgeting & Planning
- N.J. Racing Commission
- North Jersey Water Supply Commission
- Passaic Valley Sewer Commission
- Pinelands Commission
- State Commission of Investigation
- Commission of Science and Technology and all other departments, colleges, authorities and commissions as may be established in the future.

"Subcontractor" means a third party that is engaged by a contractor to perform under a subcontract all or part of the work included in a contract.

"Treasurer" means the Treasurer of the State of New Jersey or his or her designee.

17:14-1.2 Applicability and scope

(a) The rules in this subchapter are jointly promulgated by the Department of Commerce, Energy and Economic Development (hereinafter, "Department of Commerce") and the Department of Treasury to implement N.J.S.A. 52:34-12(f) which provides that a publicly bid contract is to be awarded to the responsible bidder whose bid will be most advantageous to the State, price and other factors considered. The statute further provides that any and all bids may be rejected when it is in the public interest to do so. These rules also implement N.J.S.A. 10:5-32 which provides that public works contracts shall provide for equality in opportunity by any contractor engaged in a public works project.

(b) The Treasurer and the Commissioner have determined that a "responsible" bidder does not engage in unlawful race or sex discrimination in its awarding of subcontracts and does make reasonable efforts to solicit and award subcontracts to minority and female businesses. These rules, therefore, presume that contractors who have attained or exceeded specified target levels for minority and female subcontractor participation on particular State construction contracts are not currently engaging in unlawful race or sex discrimination and have engaged in reasonable outreach efforts. A contractor who is unable to attain or exceed such target levels may have its subcontracting practices examined by the Department of Treasury to determine if it is engaging in unlawful race or sex discrimination in its selection of subcontractors or has failed to engage in reasonable outreach efforts. These rules are designed to assure that bidders receiving State construction contracts are not engaging in such unlawful discrimination and make reasonable outreach efforts.

(c) These rules apply only to State construction contracts and are not applicable to the award of State contracts for the purchase of goods and services.

(d) Applications and questions regarding eligibility as a minority business and/or female business should be addressed to:

Certification and Approvals Unit  
 Department of Commerce, Energy and  
 Economic Development  
 20 West State Street  
 CN 823  
 Trenton, New Jersey 08625

Questions concerning eligibility under this subchapter of minority businesses should be directed to:

Office of Minority Business Enterprise  
 Department of Commerce, Energy and  
 Economic Development  
 20 West State Street  
 CN 823  
 Trenton, New Jersey 08625

Questions concerning eligibility under this subchapter of female businesses should be directed to:

Office of Women Business Enterprise  
 Department of Commerce, Energy and  
 Economic Development  
 20 West State Street  
 CN 823  
 Trenton, New Jersey 08625

17:14-1.3 Standards of eligibility for minority business and female business

(a) A business may be eligible for designation as a minority business, a female business, or both.

(b) In order to be eligible as a minority business or a female business, a business must be independently owned and operated.

1. For purposes of these rules, a business shall be deemed independently owned and operated, if its management is responsible for both its daily and its long term operation, and if its management owns at least 51 percent interest in the business.

(c) In order to be eligible as a minority business, a business must satisfy the definition of minority business in 17:14-1.1

17:14-1.4 Registration procedures for minority businesses and female businesses

(a) Any business which seeks to register as a minority business and/or female business must apply to the Department of Commerce.

For these purposes, the Department of Commerce shall prepare a Vendor Registration Form. This form shall be available from the Department of Commerce, the Division of Purchase and Property and the State's other contracting agencies.

(b) As part of its application to the Department of Commerce, a business shall reasonably document its independent status, and, as appropriate, the number of its employees and the character of its ownership. Where available, this documentation should include appropriate forms or reports otherwise submitted to or issued by State and Federal agencies, such as employee or affirmative action reports filed with the New Jersey Department of Labor or certificates of incorporation issued by the New Jersey Department of State.

1. If an applicant fails to complete fully the Vendor Registration Form or to document its application, the application may be delayed or rejected.

2. If an applicant knowingly supplies incomplete or inaccurate information, the applicant shall be disqualified under these rules.

(c) In order to be registered under these rules, a business must also comply with any pre-approvals or other eligibility requirements legitimately established by the contracting agency for whose contracts the business intends to bid.

#### 17:14-1.5 Approval as a minority business or female business

(a) When a business is approved by the Department of Commerce as a minority business or female business, the business will be added by the Department of Commerce, onto the female or minority vendors lists which shall be used in determining whether bidders for State construction contracts have complied with N.J.A.C. 17:14-1.9.

(b) There shall be no limit to the number of businesses on the female and minority vendors lists. Every qualified applicant will be placed on that list or those lists for which it is qualified.

#### 17:14-1.6 Time for application to register as a minority business or female business

(a) A business may apply to the Department of Commerce at any time to be registered as a minority business or female business and to be placed on the appropriate vendors list.

(b) If a business is to be considered as a minority business or female business subcontractor on a specific contract for purposes of these rules, it must have applied to the Department of Commerce for purposes of registration no later than one day prior to the deadline for bids being received and opened by the Division of Building and Construction except as noted in (c) below.

(c) If a business is to be considered as a minority business or female business subcontractor on a contract funded by the "Correctional Facilities Construction Bond Act of 1987" for purposes of these regulations, it must meet the pre-qualification requirements of N.J.S.A. 32-2.3(b)(2) in addition to having applied to the Department of Commerce for purposes of registration no later than one day prior to the deadline for bids being received and opened by the Division of Building and Construction.

#### 17:14-1.7 Procedures for challenging a business registered as a minority business or female business

(a) The qualification under these rules of a business on a vendors list as a minority business or female business may be challenged by any other business on that State vendors list or any of the State departments, agencies, boards, commissions, committees, and authorities covered under these rules.

1. A registration challenge shall be made in writing to the Department of Commerce with copies to the challenged business and to the appropriate contracting agency where a specific contract is at issue.

2. A registration challenge to the Department of Commerce may concern only the qualification of a business under these rules as a minority business or female business. Any challenge to a business' qualifications to perform a contract shall be referred to the appropriate contracting agency.

(b) When the Department of Commerce receives a challenge, upon request of the business whose designation is at issue, the Department shall conduct a hearing on the matter as follows:

1. The Department shall notify all interested parties of the time and place of the hearing, and of the right to attend and be represented at the hearing.

2. The burden of proof lies with the challenger. However, the Department may use its own resources to ascertain the validity of a challenge and the status of a business.

3. The hearing will be conducted by the designee of the Commissioner of the Department of Commerce. This designee will issue a written report to the Commissioner within four working days of the close of the hearing.

4. Where time permits, participants at the hearing will be permitted to file written exceptions to the hearing officer's report no later than two working days from the issuance of the report.

5. Thereafter, the Commissioner shall issue a final decision on the challenge and notify the parties by certified letter.

6. A challenge to a vendor's eligibility shall not stay the contract award process.

#### 17:14-1.8 Obligation to provide information and penalties for failure to provide complete and accurate information

(a) Applicants under these rules shall accurately and honestly supply all information required by the Department of Commerce.

(b) When a business has been approved as an eligible female business or minority business on the basis of false information knowingly supplied by the business and the business has been awarded a State construction contract, the Commissioner of the Department of Commerce, after notice and opportunity for a contested case hearing pursuant to N.J.S.A. 52:14B-10 and N.J.A.C. 1:1, may:

1. Assess the business a penalty in an amount of not more than 10 percent of the amount of the contract involved; and

2. Order the business ineligible to transact any business with the State for a period of not less than three months and not more than 24 months.

(c) Any business approved by the Department of Commerce as a minority business and/or female business shall immediately apprise the Department of any circumstances which might affect the eligibility of the business under these rules.

(d) The failure of a business to report any such changed circumstances, or the intentional reporting of false information, shall disqualify the business for inclusion on any vendors list under these rules and may subject the business to adverse action by contracting agencies.

#### 17:14-1.9 Subcontracting targets

(a) The Division of Building and Construction, in consultation with the Department of Commerce, shall set target levels for the participation of minority businesses and female businesses as subcontractors for each construction contract awarded through the public bidding process. These target levels shall be set on an individual basis for each construction contract and shall be based upon the number of minority and female businesses qualified to participate as subcontractors for such contract.

(b) If the target levels are satisfied by a bidder, the bidder will be presumed not to be engaging in unlawful race and sex discrimination in the selection of subcontractors and will be presumed to have engaged in reasonable outreach efforts.

(c) If the target levels are not satisfied by a bidder, the Department of Treasury shall review the subcontracting practices of the bidder to determine if it is engaging in unlawful race or sex discrimination in the selection of subcontractors and to determine if it has engaged in reasonable outreach efforts. If said review does not indicate that the bidder is engaging in unlawful race or sex discrimination and does indicate that reasonable outreach efforts have been undertaken, the bidder will not be disqualified from bidding on that particular contract on the grounds that it discriminates in IPS selection of subcontractors and/or has not engaged in reasonable outreach efforts.

(d) In determining whether a bidder has satisfied the target levels, the award of a subcontract may count toward only one target. For example, the award of a subcontract to a business owned by a black woman may be counted either toward the minority business target or the female business target.

#### 17:14-1.10 Submission of subcontracting information

Each contractor submitting a bid for a construction contract shall include bid information, in a format determined by the Department of Treasury, as to the number and dollar value of subcontracts whose price quotes have been incorporated into the prime contractors' bid as having

## EMERGENCY ADOPTIONS

## TREASURY-GENERAL

been committed to minority and female businesses and the identity of such businesses. The bid shall include such other information as the Department of Treasury deems necessary to comply with this subchapter.

### 17:14-1.11 Severability

If any section, subsection, provision, clause or portion of this subchapter is adjudged unconstitutional or invalid by a court of compe-

tent jurisdiction, the remainder of this subchapter shall not be affected thereby.

### 17:14-1.12 Review

The operation of the construction subcontract target level program contained in this subchapter and the need for its continuation shall be reviewed by the Treasurer and the Commissioner on an annual basis.

# PUBLIC NOTICES

## EDUCATION

(a)

### STATE BOARD OF EDUCATION

#### Notice of Public Testimony Session September 20, 1989

Take notice that the following agenda items are scheduled for Notice of Proposal in the September 18, 1989 New Jersey Register and are, therefore, subject to public comment. Pursuant to the policy of the New Jersey State Board of Education, a public testimony session will be held for the purpose of receiving public comment on Wednesday, September 20, 1989 from 4:00 P.M. to 6:00 P.M. in the State Board Conference Room, Department of Education, 225 West State Street, Trenton, New Jersey.

To reserve time to speak, call Joan Boggs at (609) 292-0739 by 12:00 noon Friday, September 15, 1989.

#### RULE PROPOSALS:

- N.J.A.C. 6:11-5 and 7, Provisional Certification of First Year Teachers.
- N.J.A.C. 6:3-1.18 and 6:11-10.4, School Business Administrator Certificate.
- N.J.A.C. 6:20-2 and 2A, Bookkeeping and Accounting and Double Entry Bookkeeping and GAAP Accounting in Local Districts.
- N.J.A.C. 6:11-3 through 8, Certification of Bilingual/ESL Teachers.

## ENVIRONMENTAL PROTECTION

(b)

### DIVISION OF WATER RESOURCES

#### Amendment to the Monmouth County Water Quality Management Plan

#### Public Notice

Take notice that an amendment to the Monmouth County Water Quality Management (WQM) Plan has been submitted for approval. A Wastewater Management Plan (WMP) has been prepared for Wall Township. The WMP delineates existing sewer service areas and proposed service areas for the Township of Neptune Sewerage Authority, the South Monmouth Regional Sewerage Authority and the Manasquan River Regional Sewerage Authority/Ocean County Utilities Authority. The remainder of the township is shown as served by individual subsurface sewage disposal systems.

This notice is being given to inform the public that a plan amendment has been developed for the Monmouth County WQM Plan. All information dealing with the aforesaid WQM Plan and the proposed amendment is located at the office of NJDEP, Division of Water Resources, Bureau of Water Quality Planning, 401 East State Street, 3rd Floor, CN-029, Trenton, New Jersey 08625. It is available for inspection between 8:30 A.M. and 4:00 P.M., Monday through Friday.

Interested persons may submit written comments on the amendment to Mr. Barry Chalofsky, Bureau of Water Quality Planning, at the NJDEP address cited above. All comments must be submitted within 30 days of the date of this public notice. All comments submitted by interested persons in response to this notice, within the time limit, shall be considered by the NJDEP with respect to the amendment request.

Any interested person may request in writing that NJDEP hold a nonadversarial public hearing on the amendment. This request must state the nature of the issues to be raised at the proposed hearing and must be submitted within 30 days of the date of this public notice to Mr. Chalofsky at the NJDEP address cited above. If a public hearing is held, the public comment period in this notice shall be extended 15 days after the close of the public hearing.

## HUMAN SERVICES

(c)

### CHILDREN'S TRUST FUND

#### Notice of Availability of Grant Funds Children's Trust Fund: Prevention of Child Abuse Community Based Programs

Take notice that in compliance with N.J.S.A. 52:14-34.4 through 34.6, (P.L. 1987, c.7) the Child Life Protection Commission, the governing authority of the Children's Trust Fund, announces the following availability of funds:

- A. Name of the grant program:  
Children's Trust Fund.
- B. Purpose for which the grant program funds shall be used:  
To fund child abuse and neglect prevention programs at the community level.
- C. Amount of money in the grant program:  
Up to approximately \$500,000 dependent upon receipt of a Federal Challenge Grant award.
- D. Groups or entities which may apply for the grant program:  
Public or private agencies with 501(c)3 status for the purpose of child abuse and neglect prevention programs.
- E. Qualifications needed by an applicant to be considered for the grant program:  
An applicant must have a Federal income tax number in support of the 501(c)3 status, if a corporation—a list of trustees.
- F. Procedure for eligible entities to apply for grant funds:  
Directives and an Application will be mailed by the Children's Trust Fund upon receipt of a letter of inquiry sent to the address listed below. The completed application is to be returned to the Trust Fund for consideration.
- G. Address of division, office or official receiving application:  
Sharon L. Ahern  
Children's Trust Fund  
CN 711  
Trenton, NJ 08625
- H. Deadline by which applications must be submitting to that division, office or official:  
October 16, 1989.
- I. Date by which applicants shall be notified whether they will receive funds under the grant program:  
January 15, 1990.

## INSURANCE

(d)

### THE COMMISSIONER

#### Notice of Cancellation and Nonrenewal of Fire and Casualty Coverage

#### Public Notice

Take notice that Kenneth D. Merin, Commissioner of Insurance, pursuant to the provisions of N.J.S.A. 17:29C-3, has recertified to the Legislature the need for continuation of the notice of cancellation and nonrenewal requirement applicable to fire and casualty insurance policies, excluding accident and health policies for the fiscal year commencing July 1, 1989. The notice of cancellation and nonrenewal requirement is set forth at N.J.A.C. 11:1-5.2, which rule continues in full force and effect.

This notice is published as a matter of public information.

(a)

**THE COMMISSIONER**

**Listing of New Jersey Municipalities That Have Adopted Ordinances Pursuant to P.L. 1978, c.184, as Amended by P.L. 1979, c.369**

**Public Notice**

Take notice that Kenneth D. Merin, Commissioner of Insurance, in accordance with the provisions of N.J.S.A. 17:36-9, announces the publication of New Jersey municipalities that have adopted ordinances pursuant to the aforementioned statute. Those municipalities, if any, which have adopted said ordinances since the previous date of publication shall be designated by asterisk.

**LIST OF MUNICIPALITIES REQUIRING PAYMENT OF LIENS BY COMPANIES WRITING FIRE INSURANCE**

The following is a list of municipalities that have passed an ordinance requiring companies writing fire insurance on risks located in that municipality to pay unpaid liens out of any claimed payments in excess of \$2,500.

|   | Date Filed with the<br>Department of Insurance |
|---|--|
| Aberdeen, Township of 07747 (Monmouth County)         | September 8, 1980                              |
| Absecon, City of 08201 (Atlantic County)              | July 5, 1983                                   |
| Alloway, Township of 08079 (Salem County)             | December 20, 1984                              |
| Asbury Park, City of 07712 (Monmouth County)          | May 25, 1979                                   |
| Atlantic City, City of 08401 (Atlantic County)        | March 19, 1979                                 |
| Barrington, Borough of 08007 (Camden County)          | September 17, 1982                             |
| Bayonne, City of 07002 (Hudson County)                | March 12, 1979                                 |
| Belmar, Borough of 07719 (Monmouth County)            | March 5, 1982                                  |
| Berkeley, Township of 08721 (Ocean County)            | May 22, 1979                                   |
| Berlin, Borough of 08009 (Camden County)              | October 18, 1979                               |
| Berlin, Township of 08091 (Camden County)             | March 20, 1980                                 |
| Bloomfield, Town of 07003 (Essex County)              | March 26, 1979                                 |
| Brick, Township of 08723 (Ocean County)               | May 2, 1980                                    |
| Bridgeton, City of 08302 (Cumberland County)          | April 30, 1979                                 |
| Brigantine, City of 08203 (Atlantic County)           | October 14, 1982                               |
| Buena, Borough of 08341 (Atlantic County)             | November 1, 1982                               |
| Burlington, City of 08016 (Burlington County)         | December 9, 1986                               |
| Butler, Borough of 07405 (Morris County)              | November 14, 1980                              |
| Byram, Township of 07860 (Sussex County)              | October 9, 1980                                |
| Camden, City of 08101 (Camden County)                 | May 4, 1979                                    |
| Cape May, City of 08204 (Cape May County)             | May 22, 1979                                   |
| Carneys Point, Township of 08069 (Salem County)       | July 2, 1979                                   |
| Cedar Grove, Township of 07009 (Essex County)         | August 10, 1979                                |
| Chatham, Township of 07928 (Morris County)            | June 4, 1986                                   |
| Cinnaminson, Township of 08077 (Burlington County)    | August 30, 1979                                |
| Clinton, Township of 08801 (Hunterdon County)         | December 10, 1981                              |
| Delran, Township of 08075 (Burlington County)         | August 30, 1979                                |
| Dover, Town of 07801 (Morris County)                  | April 16, 1980                                 |
| Dover, Township of 08753 (Ocean County)               | September 26, 1979                             |
| East Orange, City of 07019 (Essex County)             | February 20, 1979                              |
| Eatontown, Borough of 07724 (Monmouth County)         | March 23, 1979                                 |
| Edgewater Park, Township of 08010 (Burlington County) | July 24, 1979                                  |
| Egg Harbor, Township of 08221 (Atlantic County)       | September 24, 1979                             |
| Egg Harbor, City of 08215 (Atlantic County)           | May 21, 1981                                   |
| Elizabeth, City of 07201 (Union County)               | April 30, 1979                                 |
| Ewing, Township of 08618 (Mercer County)              | November 10, 1981                              |
| Fairfield, Township of 07006 (Essex County)           | August 21, 1980                                |
| Fair View, Borough of 07022 (Bergen County)           | September 5, 1979                              |
| Fanwood, Borough of 07023 (Union County)              | June 29, 1979                                  |
| Farmingdale, Borough of 07727 (Union County)          | May 18, 1981                                   |
| Florham Park, Borough of 07932 (Morris County)        | April 25, 1979                                 |
| Fort Lee, Borough of 07024 (Bergen County)            | August 27, 1979                                |
| Franklin, Township of 07826 (Somerset County)         | June 20, 1980                                  |
| Gloucester, City of 08030 (Camden County)             | January 24, 1989                               |
| Fredon, Township of 07860 (Sussex County)             | October 28, 1980                               |
| Green, Township of 07821 (Sussex County)              | July 20, 1982                                  |
| Hackensack, City of 07602 (Bergen County)             | April 22, 1980                                 |
| Hamilton, Township of 08330 (Atlantic County)         | November 18, 1982                              |
| Hammonton, Town of 08037 (Atlantic County)            | August 3, 1979                                 |
| Hanover, Township of 07981 (Morris County)            | January 7, 1986                                |

|  |                    |
|--|--------------------|
| Hightstown, Borough of 08520 (Mercer County)         | September 3, 1980  |
| Hillside, Township of 07205 (Union County)           | June 4, 1979       |
| Hoboken, City of 07030 (Hudson County)               | October 15, 1979   |
| Holmdel, Township of 07733 (Monmouth County)         | October 20, 1987   |
| Hopewell, Township of 08302 (Cumberland County)      | September 26, 1979 |
| Howell, Township of 07731 (Monmouth County)          | March 23, 1979     |
| Irvington, Town of 07111 (Essex County)              | March 20, 1979     |
| Irvington, Township of 07111 (Essex County)          | July 1, 1985       |
| Jackson, Township of 08257 (Ocean County)            | March 7, 1979      |
| Jamesburg, Borough of 08831 (Middlesex County)       | March 2, 1983      |
| Jefferson, Township of 07981 (Morris County)         | April 19, 1983     |
| Jersey City, City of 07302 (Hudson County)           | February 23, 1979  |
| Keansburg, Township of 07734 (Monmouth County)       | April 5, 1984      |
| Kearny, Town of 07032 (Hudson County)                | August 26, 1980    |
| Keyport, Borough of 07735 (Monmouth County)          | August 15, 1979    |
| Kinnelon, Borough of 07405 (Morris County)           | June 4, 1986       |
| Lacey, Township of 08731 (Ocean County)              | August 18, 1981    |
| Lavallette, Borough of 08735 (Ocean County)          | December 11, 1979  |
| Lawrence, Township of 08648 (Mercer County)          | April 24, 1979     |
| Little Silver, Borough of 07739 (Monmouth County)    | April 5, 1984      |
| Long Branch, City of 07740 (Monmouth County)         | December 4, 1987   |
| Loptacong, Township of 08865 (Warren County)         | August 30, 1979    |
| Lower, Township of 08024 (Cape May County)           | June 5, 1979       |
| Manchester, Township of 08733 (Ocean County)         | September 21, 1982 |
| Mannington, Township of 08079 (Salem County)         | May 17, 1979       |
| Maple Shade, Township of 08052 (Burlington County)   | July 18, 1980      |
| Maplewood, Township of 07040 (Essex County)          | April 4, 1979      |
| Matawan, Borough of 07747 (Monmouth County)          | June 19, 1981      |
| Maurice River, Township of 08332 (Cumberland County) | September 26, 1980 |
| Mendham, Township of 07949 (Morris County)           | January 16, 1985   |
| Millburn, Township of 07041 (Essex County)           | May 19, 1981       |
| Millville, City of 08332 (Cumberland County)         | April 10, 1979     |
| Millstone, Township of 07726 (Monmouth County)       | January 14, 1988   |
| Montclair, Town of 07042 (Essex County)              | April 5, 1979      |
| Mount Holly, Township of 08060 (Burlington County)   | January 29, 1980   |
| Mount Laurel, Township of 08054 (Burlington County)  | May 27, 1980       |
| Neptune, Township of 07753 (Monmouth County)         | January 4, 1982    |
| Neptune City, Borough of 07712 (Monmouth County)     | December 2, 1982   |
| Newark, City of 07102 (Essex County)                 | March 16, 1979     |
| New Brunswick, City of 08903 (Middlesex County)      | January 30, 1986   |
| North Plainfield, Borough of 07060 (Somerset County) | July 1, 1985       |
| North Wildwood, City of 08260 (Cape May County)      | August 24, 1979    |
| Ocean, Township of 07755 (Monmouth County)           | November 27, 1979  |
| Ocean, Township of 08758 (Ocean County)              | May 29, 1985       |
| Orange, City of 07050 (Essex County)                 | July 2, 1979       |
| Passaic, City of 07055 (Passaic County)              | September 4, 1980  |
| Paterson, City of 07050 (Passaic County)             | February 16, 1979  |
| Paulsboro, Borough of 08066 (Gloucester County)      | May 7, 1981        |
| Penns Grove, Borough of 08069 (Salem County)         | July 9, 1979       |
| Phillipsburg, Town of 08865 (Warren County)          | July 13, 1979      |
| Pine Hill, Borough of 08021 (Camden County)          | March 2, 1982      |
| Piscataway, Township of 08854 (Middlesex County)     | March 20, 1981     |
| Plainfield, City of 07061 (Union County)             | April 5, 1979      |
| Pleasantville, City of 08232 (Atlantic County)       | December 27, 1979  |
| Pohatcong, Township of 08865 (Warren County)         | July 20, 1979      |
| Princeton, Borough of 08540 (Mercer County)          | July 16, 1980      |
| Princeton, Township of 08540 (Mercer County)         | September 25, 1980 |
| Rahway, City of 07065 (Union County)                 | December 18, 1979  |
| Randolph, Township of 07801 (Morris County)          | May 10, 1979       |
| Readington, Township of 08889 (Hunterdon County)     | June 23, 1980      |
| Red Bank, Borough of 07701 (Monmouth County)         | September 9, 1980  |
| Riverside, Township of 08075 (Burlington County)     | May 10, 1979       |
| Roselle, Borough of 07203 (Union County)             | August 8, 1979     |
| Roselle Park, Borough of 07204 (Union County)        | March 5, 1981      |
| Runnemede, Borough of 08078 (Camden County)          | May 6, 1982        |
| Salem, City of 08079 (Salem County)                  | June 20, 1979      |

|   |                    |
|---|--------------------|
| Sayreville, Borough of 08872 (Middlesex County)         | September 19, 1979 |
| Scotch Plains, Township of 07076 (Union County)         | August 22, 1979    |
| Sea Bright, Borough of 07760 (Monmouth County)          | April 10, 1979     |
| Secaucus, Town of 07094 (Hudson County)                 | March 5, 1980      |
| Somerdale, Borough of 08083 (Camden County)             | July 28, 1982      |
| Somerville, Borough of 08876 (Somerset County)          | March 23, 1979     |
| South Amboy, City of 08879 (Middlesex County)           | July 12, 1984      |
| South Harrison, Township of 08039 (Gloucester County)   | December 29, 1988  |
| South Orange Village, Township of 07079 (Essex County)  | August 19, 1980    |
| South Plainfield, Borough of 07080 (Middlesex County)   | September 26, 1980 |
| South River, Borough of 08882 (Middlesex County)        | March 16, 1979     |
| Spotswood, Borough of 08884 (Middlesex County)          | June 19, 1981      |
| Stafford, Township of 08050 (Ocean County)              | May 2, 1985        |
| Sussex, Borough of 07461 (Sussex County)                | October 24, 1979   |
| Tenafly, Borough of 07670 (Bergen County)               | June 17, 1980      |
| Tinton Falls, Township of 07724 (Monmouth County)       | June 20, 1980      |
| Trenton, City of 08608 (Mercer County)                  | June 12, 1980      |
| Tuckerton, Borough of 08087 (Ocean County)              | February 2, 1989   |
| Union City, City of 07087 (Hudson County)               | April 23, 1979     |
| Upper Deerfield, Township of 08302 (Cumberland County)* | May 19, 1989       |
| Upper Pittsgrove, Township of 08318 (Salem County)      | October 15, 1979   |
| Ventnor City, City of 08401 (Atlantic County)           | March 30, 1982     |
| Verona, Borough of, Township of 07044 (Essex County)    | February 23, 1984  |
| Victory Gardens, Borough of 07801 (Morris County)       | August 15, 1979    |
| Vineland, City of 08360 (Cumberland County)             | July 6, 1979       |
| Washington, Borough of 07882 (Warren County)            | June 24, 1986      |
| Washington, Township of 08214 (Burlington County)       | March 12, 1979     |
| Washington, Township of 07853 (Morris County)           | May 30, 1979       |
| Waterford, Township of 08004 (Camden County)            | July 9, 1984       |
| Wayne, Township of 07470 (Passaic County)               | October 6, 1986    |
| Weehawken, Township of 07087 (Hudson County)            | August 14, 1986    |
| Wenonah, Borough of 08090 (Gloucester County)           | July 1, 1985       |
| West Deptford, Township of 08086 (Gloucester County)    | November 14, 1988  |
| Westhampton, Township of 08060 (Burlington County)      | June 4, 1979       |
| West New York, Town of 07093 (Hudson County)            | March 16, 1979     |
| Westville, Borough of 08093 (Gloucester County)         | March 18, 1988     |
| West Orange, Town of 07052 (Essex County)               | February 26, 1979  |
| Wildwood, City of 08260 (Cape May County)               | December 5, 1984   |
| Willingboro, Township of 08046 (Burlington County)      | April 17, 1980     |
| Winslow, Township of 08037 (Camden County)              | November 13, 1980  |
| Woodbury, City of 08086 (Gloucester County)             | January 7, 1986    |
| Woodlynne, Borough of 08107 (Camden County)             | June 7, 1982       |
| Woodridge, Borough of 07075 (Bergen County)             | July 9, 1984       |
| Woodstown, Borough of 08079 (Salem County)              | September 8, 1983  |

## LAW AND PUBLIC SAFETY

### (a)

#### STATE BOARD OF MEDICAL EXAMINERS

##### Petition for Rulemaking Physician Assistants

##### N.J.A.C. 13:35

Petitioner: New Jersey State Society of Physician Assistants.

Authority: N.J.S.A. 52:14B-4(f).

**Take notice** that on July 11, 1989, petitioner filed a petition with the State Board of Medical Examiners requesting the Board to promulgate rules and regulations to authorize the practice of physician assistants within the State of New Jersey.

The petition follows:

1. Petitioner New Jersey State Society of Physician Assistants, a member of the American Academy of Physician Assistants, and a group of accredited practitioners with its principal address at P.O. Box 1282, Piscataway, N.J. 08855-1282, respectfully petitions the New Jersey Board of Medical Examiners, pursuant to N.J.S.A. 52:14B-4(f), to promulgate rules and regulations to authorize the practice of physician assistants within the State of New Jersey.

2. The New Jersey Board of Medical Examiners has the authority to promulgate these regulations pursuant to its enabling statute, N.J.S.A. 45:9-1 et seq. Attached hereto as Exhibits A and B respectively are a June 2, 1986 letter from Petitioner's counsel and a June 7, 1989 letter from Attorney General Peter N. Perretti which recite the basis for the Board's authority to take the requested action.

3. The reasons for the request are as follows:

A. Physician assistants practice currently in 49 states and the District of Columbia. Authorization of their practice in this State could substantially improve health care in New Jersey and act as a significant constraint on rising health care costs. Physician assistants would not supplant any existing health care professionals but would enhance a team medical care approach, facilitate communication and provide the nursing staff with reliable support.

B. By performing routine medical procedures, physician assistants could free overworked doctors to tackle complex and challenging problems, while simultaneously lowering health care costs due to their much lower compensation rate. Moreover, physician assistants are a cost-effective solution to the problem of understaffing at hospitals that the state-wide decrease in the number of, and enrollment in, residency programs has caused.

C. The practice of physician assistants is ideally suited to target some of the problem areas of health care in New Jersey today. As the State with the fourth largest number of AIDS patients, there is a real need in New Jersey for physician assistants whose practice in this area can improve patient care, reduce costs and lessen the burden on overworked physicians.

D. The growing number of elderly patients in New Jersey and the shortage of doctors in nursing homes has put a great strain on the few available doctors. Utilization of physician assistants to perform routine medical procedures under physician supervision could greatly reduce the workload of these doctors and improve patient care.

E. The practice of physician assistants in New Jersey could provide a cost effective method of improving health care in underserved rural and urban areas, reducing the workload of the few physicians present and possibly, by reducing the strenuous workload and making practice more pleasant, attracting more physicians to these areas.

F. Not only is there a great need in New Jersey for physician assistants, but one of the best physician assistant training programs in the country is located in New Jersey. Since 1975 the University of Medicine and Dentistry and Rutgers University have operated an accredited physician assistant training program, graduating over 175 physician assistants. The scores of these graduates on national examinations have placed the program among the top five schools nationally. However, as the Board of Medical Examiners has not formulated regulations these bright young practitioners have been forced to practice out of state.

4. In January 1987 the Cardiac Services Task Force of the State Department of Health endorsed the utilization of physician assistants in New Jersey cardiac care units because of their cost effectiveness and quality of service.

5. After a September 16, 1987 public hearing by its Plan Development and Implementation Committee, the State Health Coordinating Council voted to endorse physician assistants' practice in this State.

6. Based upon the aforesaid authority and for the reasons herein set forth, petitioner respectfully petitions the New Jersey Board of Medical Examiners to authorize in New Jersey the practice of physician assistants and to promulgate regulations therefor. The Attorney General has opined that these regulations should at a minimum specify with particularity the necessary training and experience required to be a physician assistant, the procedures physician assistants may undertake, the degree of physician supervision required for each allowed procedure, and the recordkeeping requirements to be followed. The summaries of the regulations of our bordering states, New York and Pennsylvania, have been attached as suggested models for the New Jersey regulations (Exhibits "C" and "D").

WHEREFORE, Petitioner requests that the New Jersey Board of Medical Examiners promulgate rules authorizing the practice of physician

assistants and providing regulations for the governance of this practice within 30 days pursuant to N.J.S.A. 52:14B-4(f).

After due notice, this petition will be considered by the State Board of Medical Examiners in accordance with the provisions of N.J.S.A. 52:14B-4(f).

---

(a)

## STATE BOARD OF MORTUARY SCIENCE

### Petition for Rulemaking

### Prohibition on Funeral Directors Making Removals Prior to Pronouncement

#### N.J.A.C. 13:36

Petitioners: New Jersey State Funeral Directors Association.

Authority: N.J.S.A. 52:14B-4(f); N.J.A.C. 1:30-3.6.

**Take notice** that on July 31, 1989, petitioners, on behalf of 729 members, filed a petition with the State Board of Mortuary Science requesting a new rule to prohibit all licensees of the State Board of Mortuary Science from making removals of human remains prior to an official pronouncement of death.

Petitioners suggest the following specific language for the new rule:

No practitioner of mortuary science, embalmer, funeral director, funeral home employee, agent of a funeral home or licensee shall remove a person from the place of death until a pronouncement of death is made

by a licensed physician, a licensed registered nurse or a paramedic certified by the Board of Medical Examiners; except that a body may be removed before a pronouncement when the person making such removal is acting as an agent of, and at the direction of, the medical examiner.

Petitioners state that: "The need for this amendment to the Administrative Code is the result of an amendment proposed by the State Board of Medical Examiners at 21 N.J.R. 1969(b), PRN 1989-369, wherein in adjusting various procedures and requirements for physicians with respect to their obligations to make pronouncements at the scene of a death, they are proposing the regularized removal of human remains from the scene of death prior to pronouncement, to locations more suitable to the attending physician. This will impose requests, obligations and pressures on funeral directors to make removals prior to pronouncements, an act which is not in their best interest or that of the public. Funeral directors are not qualified to make judgments about the appropriateness of such moves because a pronouncement is a medical determination. There are repeated cases of persons being removed from scenes who are 'presumed' dead but who are not in fact. Moving such remains will dramatically increase funeral director liability and exposure, while it reduces physician and medical examiner obligations. It will also lead to situations where potential threats will be made against funeral directors by persons at a scene such that 'if they don't remove the remains' prior to pronouncement, they will advise the family of a funeral director who will."

After due notice, this petition will be considered by the State Board of Mortuary Science in accordance with the provisions of N.J.S.A. 52:14B-4(f).

---

# EXECUTIVE ORDER NO. 66(1978) EXPIRATION DATES

Pursuant to N.J.A.C. 1:30-4.4, all expiration dates are now affixed at the chapter level. The following table is a complete listing of all current New Jersey Administrative Code expiration dates by Title and Chapter. If a chapter is not cited, then it does not have an expiration date. In some instances, however, exceptions occur to the chapter-level assignment. These variations do appear in the listing along with the appropriate chapter citation, and are noted either as an exemption from Executive Order No. 66(1978) or as a subchapter-level date differing from the chapter date.

Current expiration dates may also be found in the loose-leaf volumes of the Administrative Code under the Title Table of Contents for each executive department or agency and on the Subtitle page for each group of chapters in a Title. Please disregard all expiration dates appearing elsewhere in a Title volume.

This listing is revised monthly and appears in the first issue of each month.

## OFFICE OF ADMINISTRATIVE LAW—TITLE 1

| N.J.A.C. | Expiration Date |
|----------|-----------------|
| 1:1      | 5/4/92          |
| 1:5      | 10/20/91        |
| 1:6      | 5/4/92          |
| 1:6A     | 5/4/92          |
| 1:7      | 5/4/92          |
| 1:10     | 5/4/92          |
| 1:10A    | 5/4/92          |
| 1:10B    | 10/6/91         |
| 1:11     | 5/4/92          |
| 1:13     | 5/4/92          |
| 1:13A    | 4/3/94          |
| 1:20     | 5/4/92          |
| 1:21     | 5/4/92          |
| 1:30     | 2/14/91         |
| 1:31     | 6/17/92         |

| N.J.A.C. | Expiration Date |
|----------|-----------------|
| 3:21     | 2/2/92          |
| 3:22     | 5/12/94         |
| 3:23     | 7/6/92          |
| 3:24     | 8/20/89         |
| 3:25     | 8/17/92         |
| 3:26     | 12/31/90        |
| 3:27     | 9/16/90         |
| 3:28     | 12/17/89        |
| 3:30     | 10/17/88        |
| 3:32     | 10/1/93         |
| 3:38     | 10/5/92         |
| 3:41     | 10/16/90        |
| 3:42     | 4/4/93          |

## AGRICULTURE—TITLE 2

| N.J.A.C. | Expiration Date                                   |
|----------|---|
| 2:1      | 9/3/90  |
| 2:2      | 1/17/94   |
| 2:3      | 8/21/94   |
| 2:5      | 8/21/94   |
| 2:6      | 9/3/90  |
| 2:9      | 7/7/91  |
| 2:16     | 5/7/90  |
| 2:22     | 7/6/92  |
| 2:23     | 7/18/93   |
| 2:24     | 2/11/90   |
| 2:32     | 6/1/92  |
| 2:33     | 3/6/94  |
| 2:48     | 11/27/90  |
| 2:50     | 5/1/92  |
| 2:52     | 6/7/90  |
| 2:53     | 3/3/91  |
| 2:54     | Exempt<br>(7 U.S.C. 601 et seq.<br>7 C.F.R. 1004) |
| 2:68     | 11/7/93   |
| 2:69     | 11/7/93   |
| 2:70     | 5/7/90  |
| 2:71     | 7/8/93  |
| 2:72     | 7/8/93  |
| 2:73     | 7/8/93  |
| 2:74     | 7/8/93  |
| 2:76     | 7/31/94   |
| 2:90     | 6/24/90   |

## PERSONNEL (CIVIL SERVICE)—TITLE 4/4A

| N.J.A.C. | Expiration Date |
|----------|-----------------|
| 4:1      | 1/28/90         |
| 4:2      | 1/28/90         |
| 4:3      | 6/4/89          |
| 4:4      | 12/5/91         |
| 4:6      | 5/5/91          |
| 4A:1     | 10/5/92         |
| 4A:2     | 10/5/92         |
| 4A:3     | 9/6/93          |
| 4A:4     | 6/6/93          |
| 4A:5     | 10/5/92         |
| 4A:6     | 1/4/93          |
| 4A:7     | 10/5/92         |
| 4A:9     | 10/5/92         |
| 4A:10    | 11/2/92         |

## COMMUNITY AFFAIRS—TITLE 5

| N.J.A.C. | Expiration Date |
|----------|-----------------|
| 5:2      | 4/10/94         |
| 5:3      | 9/1/93          |
| 5:4      | 10/5/92         |
| 5:10     | 11/17/93        |
| 5:11     | 3/10/94         |
| 5:12     | 1/1/90          |
| 5:13     | 12/24/92        |
| 5:14     | 12/1/90         |
| 5:15     | 5/1/94          |
| 5:17     | 6/1/89          |
| 5:18     | 2/1/90          |
| 5:18A    | 2/1/90          |
| 5:18B    | 2/1/90          |
| 5:19     | 2/1/93          |
| 5:22     | 12/1/90         |
| 5:23     | 3/1/93          |
| 5:24     | 9/1/90          |
| 5:25     | 3/1/91          |
| 5:26     | 3/1/91          |
| 5:27     | 6/1/90          |
| 5:28     | 12/20/90        |
| 5:29     | 6/18/91         |
| 5:30     | 6/29/93         |
| 5:31     | 12/1/89         |
| 5:37     | 11/18/90        |
| 5:38     | 10/27/93        |
| 5:51     | 9/1/93          |

## BANKING—TITLE 3

| N.J.A.C. | Expiration Date |
|----------|-----------------|
| 3:1      | 1/6/91          |
| 3:2      | 4/15/90         |
| 3:6      | 3/3/91          |
| 3:7      | 9/16/90         |
| 3:11     | 5/1/94          |
| 3:13     | 11/17/91        |
| 3:17     | 6/18/91         |
| 3:18     | 1/19/93         |
| 3:19     | 3/17/91         |

| N.J.A.C. | Expiration Date |
|----------|-----------------|
| 5:70     | 7/9/92          |
| 5:71     | 3/1/90          |
| 5:80     | 5/20/90         |
| 5:91     | 6/16/91         |
| 5:92     | 6/16/91         |
| 5:100    | 5/5/94          |

| N.J.A.C. | Expiration Date |
|----------|-----------------|
| 7:19     | 4/15/90         |
| 7:19A    | 2/19/90         |
| 7:19B    | 2/19/90         |
| 7:20     | 5/6/90          |
| 7:20A    | 12/16/93        |
| 7:22     | 1/5/92          |
| 7:23     | 6/9/94          |
| 7:24     | 5/19/91         |
| 7:25     | 2/18/91         |
| 7:25A    | 5/6/90          |
| 7:26     | 11/4/90         |
| 7:26B    | 12/21/92        |
| 7:27     | Exempt          |
| 7:27B-3  | Exempt          |
| 7:28     | 10/7/90         |
| 7:29     | 3/18/90         |
| 7:29B    | 2/1/93          |
| 7:30     | 12/4/92         |
| 7:31     | 6/20/93         |
| 7:36     | 11/21/93        |
| 7:37     | Exempt          |
| 7:38     | 9/18/90         |
| 7:45     | 2/6/94          |

**DEPARTMENT OF MILITARY AND VETERANS' AFFAIRS—TITLE 5A**

| N.J.A.C. | Expiration Date |
|----------|-----------------|
| 5A:2     | 5/20/90         |

**EDUCATION—TITLE 6**

| N.J.A.C. | Expiration Date |
|----------|-----------------|
| 6:2      | 2/6/94          |
| 6:3      | 7/8/93          |
| 6:8      | 1/5/92          |
| 6:11     | 12/12/90        |
| 6:12     | 4/2/91          |
| 6:20     | 8/9/90          |
| 6:21     | 8/9/90          |
| 6:22     | 9/3/90          |
| 6:22A    | 12/19/93        |
| 6:24     | 4/2/91          |
| 6:26     | 1/24/90         |
| 6:27     | 1/24/90         |
| 6:28     | 4/10/94         |
| 6:29     | 3/25/90         |
| 6:30     | 7/5/93          |
| 6:31     | 1/24/90         |
| 6:39     | 8/14/94         |
| 6:43     | 4/7/91          |
| 6:46     | 10/5/92         |
| 6:53     | 7/7/92          |
| 6:64     | 1/11/93         |
| 6:68     | 4/12/90         |
| 6:69     | 6/4/91          |
| 6:70     | 1/25/90         |
| 6:78     | 11/7/93         |
| 6:79     | 11/25/92        |

**ENVIRONMENTAL PROTECTION—TITLE 7**

| N.J.A.C. | Expiration Date |
|----------|-----------------|
| 7:1      | 9/16/90         |
| 7:1A     | 6/5/92          |
| 7:1C     | 6/17/90         |
| 7:1D     | 11/28/93        |
| 7:1E     | 7/15/90         |
| 7:1F     | 4/20/92         |
| 7:1G     | 10/1/89         |
| 7:1H     | 7/24/90         |
| 7:1I     | 7/18/93         |
| 7:2      | 6/24/93         |
| 7:3      | 3/21/93         |
| 7:6      | 6/9/94          |
| 7:7      | 5/12/94         |
| 7:7A     | 6/6/93          |
| 7:7E     | 7/24/90         |
| 7:7F     | 1/19/93         |
| 7:8      | 2/5/93          |
| 7:9      | 1/21/91         |
| 7:9A     | 8/21/94         |
| 7:10     | 9/4/89          |
| 7:11     | 5/13/93         |
| 7:12     | 4/11/93         |
| 7:13     | 7/14/94         |
| 7:14     | 4/27/94         |
| 7:14A    | 6/2/94          |
| 7:14B    | 12/21/92        |
| 7:15     | 4/2/89          |
| 7:17     | 4/7/91          |
| 7:18     | 8/6/91          |

**HEALTH—TITLE 8**

| N.J.A.C. | Expiration Date |
|----------|-----------------|
| 8:7      | 9/16/90         |
| 8:8      | 4/12/94         |
| 8:9      | 2/18/91         |
| 8:13     | 9/8/92          |
| 8:19     | 6/28/90         |
| 8:20     | 3/4/90          |
| 8:21     | 11/18/90        |
| 8:21A    | 4/1/90          |
| 8:22     | 8/4/91          |
| 8:23     | 12/17/89        |
| 8:24     | 5/2/93          |
| 8:25     | 5/19/93         |
| 8:26     | 8/4/91          |
| 8:31     | 11/5/89         |
| 8:31A    | 3/18/90         |
| 8:31B    | 10/15/90        |
| 8:31C    | 1/20/92         |
| 8:33     | 10/7/90         |
| 8:33A    | 4/15/90         |
| 8:33B    | 10/7/90         |
| 8:33C    | 7/17/91         |
| 8:33E    | 6/23/92         |
| 8:33F    | 1/14/90         |
| 8:33G    | 7/17/94         |
| 8:33H    | 7/19/90         |
| 8:33I    | 9/15/91         |
| 8:33J    | 4/24/94         |
| 8:33K    | 3/27/94         |
| 8:33M    | 7/17/94         |
| 8:33N    | 5/15/94         |
| 8:34     | 11/15/93        |
| 8:39     | 6/20/93         |
| 8:40     | 4/15/90         |
| 8:41     | 2/17/92         |
| 8:42     | 8/17/92         |
| 8:42A    | 6/19/94         |
| 8:42B    | 7/18/93         |
| 8:43     | 1/21/91         |
| 8:43A    | 9/3/90          |
| 8:43B    | 1/21/91         |
| 8:43E    | 12/11/92        |
| 8:43F    | 3/18/90         |
| 8:43G    | 9/8/91          |
| 8:43H    | 8/21/94         |
| 8:43I    | 3/21/93         |
| 8:44     | 11/2/93         |
| 8:45     | 5/20/90         |
| 8:48     | 8/20/89         |
| 8:51     | 9/16/90         |

| N.J.A.C. | Expiration Date |
|----------|-----------------|
| 8:52     | 12/15/91        |
| 8:53     | 8/4/91          |
| 8:57     | 6/18/90         |
| 8:59     | 10/1/89         |
| 8:60     | 5/3/90          |
| 8:61     | 10/6/91         |
| 8:65     | 12/2/90         |
| 8:70     | 8/19/93         |
| 8:71     | 2/17/94         |

| N.J.A.C. | Expiration Date |
|----------|-----------------|
| 10:69B   | 11/21/93        |
| 10:70    | 6/16/91         |
| 10:71    | 1/6/91          |
| 10:72    | 8/27/92         |
| 10:80    | 5/19/94         |
| 10:81    | 10/15/89        |
| 10:82    | 10/29/89        |
| 10:83    | 1/19/94         |
| 10:85    | 1/30/90         |
| 10:87    | 1/27/94         |
| 10:89    | 9/11/90         |
| 10:90    | 10/14/92        |
| 10:94    | 1/6/91          |
| 10:95    | 8/23/89         |
| 10:97    | 5/15/94         |
| 10:99    | 2/19/90         |
| 10:109   | 3/17/91         |
| 10:112   | 2/17/89         |
| 10:120   | 8/21/91         |
| 10:121   | 3/13/89         |
| 10:121A  | 12/7/92         |
| 10:122   | 5/15/94         |
| 10:122A  | Exempt          |
| 10:122B  | 9/10/89         |
| 10:123   | 7/29/90         |
| 10:124   | 12/7/92         |
| 10:125   | 7/16/89         |
| 10:126   | 11/7/93         |
| 10:127   | 8/26/93         |
| 10:129   | 10/11/89        |
| 10:130   | 9/19/88         |
| 10:131   | 12/7/92         |
| 10:132   | 1/5/92          |
| 10:141   | 2/7/94          |

### HIGHER EDUCATION—TITLE 9

| N.J.A.C. | Expiration Date |
|----------|-----------------|
| 9:1      | 2/21/94         |
| 9:2      | 6/17/90         |
| 9:3      | 9/27/93         |
| 9:4      | 10/30/91        |
| 9:5      | 1/21/91         |
| 9:6      | 5/20/90         |
| 9:6A     | 1/4/93          |
| 9:7      | 2/28/93         |
| 9:8      | 11/4/90         |
| 9:9      | 10/3/93         |
| 9:11     | 4/17/94         |
| 9:12     | 4/17/94         |
| 9:14     | 5/20/90         |
| 9:15     | 8/21/94         |

### HUMAN SERVICES—TITLE 10

| N.J.A.C. | Expiration Date |
|----------|-----------------|
| 10:1     | 11/7/93         |
| 10:2     | 1/5/92          |
| 10:3     | 11/21/93        |
| 10:4     | 1/3/88          |
| 10:6     | 2/21/89         |
| 10:12    | 1/5/92          |
| 10:13    | 7/18/93         |
| 10:14    | 5/16/93         |
| 10:31    | 6/5/94          |
| 10:36    | 8/18/91         |
| 10:37    | 11/4/90         |
| 10:38    | 5/28/91         |
| 10:39    | 2/21/94         |
| 10:40    | 5/11/94         |
| 10:41    | 3/20/94         |
| 10:42    | 8/18/91         |
| 10:43    | 8/21/94         |
| 10:44    | 10/3/88         |
| 10:44A   | 11/21/93        |
| 10:44B   | 4/15/90         |
| 10:45    | 9/19/88         |
| 10:47    | 11/4/90         |
| 10:48    | 1/21/91         |
| 10:49    | 8/12/90         |
| 10:50    | 3/3/91          |
| 10:51    | 10/28/90        |
| 10:52    | 2/19/90         |
| 10:53    | 4/29/90         |
| 10:54    | 3/3/91          |
| 10:55    | 3/11/90         |
| 10:56    | 8/26/91         |
| 10:57    | 3/3/91          |
| 10:58    | 3/3/91          |
| 10:59    | 3/3/91          |
| 10:60    | 8/27/90         |
| 10:61    | 3/3/91          |
| 10:62    | 3/3/91          |
| 10:63    | 11/29/89        |
| 10:64    | 3/3/91          |
| 10:65    | 11/5/89         |
| 10:66    | 12/15/93        |
| 10:67    | 3/3/91          |
| 10:68    | 7/7/91          |
| 10:69    | 6/6/93          |
| 10:69A   | 4/20/93         |

### CORRECTIONS—TITLE 10A

| N.J.A.C. | Expiration Date |
|----------|-----------------|
| 10A:1    | 7/6/92          |
| 10A:3    | 10/6/91         |
| 10A:4    | 7/21/91         |
| 10A:5    | 10/6/91         |
| 10A:6    | 11/2/92         |
| 10A:8    | 11/16/92        |
| 10A:9    | 1/20/92         |
| 10A:10-6 | 8/17/92         |
| 10A:16   | 4/6/92          |
| 10A:17   | 12/15/91        |
| 10A:18   | 7/6/92          |
| 10A:19   | 8/21/94         |
| 10A:22   | 7/5/93          |
| 10A:31   | 2/4/90          |
| 10A:32   | 3/4/90          |
| 10A:33   | 5/2/94          |
| 10A:34   | 4/6/92          |
| 10A:70   | Exempt          |
| 10A:71   | 4/15/90         |

### INSURANCE—TITLE 11

| N.J.A.C. | Expiration Date |
|----------|-----------------|
| 11:1     | 2/3/91          |
| 11:1-20  | 6/24/90         |
| 11:1-22  | 6/24/90         |
| 11:2     | 12/2/90         |
| 11:3     | 1/6/91          |
| 11:4     | 12/2/90         |
| 11:5     | 10/28/93        |
| 11:7     | 10/19/92        |
| 11:10    | 7/15/90         |
| 11:12    | 10/27/91        |
| 11:13    | 11/12/92        |
| 11:15    | 12/3/89         |
| 11:16    | 2/3/91          |
| 11:17    | 4/18/93         |

**LABOR—TITLE 12**

| N.J.A.C. | Expiration Date |
|----------|-----------------|
| 12:3     | 12/19/93        |
| 12:5     | 9/19/93         |
| 12:6     | 10/17/93        |
| 12:15    | 8/19/90         |
| 12:16    | 4/1/90          |
| 12:17    | 1/6/91          |
| 12:18    | 3/7/93          |
| 12:20    | 8/14/94         |
| 12:35    | 8/5/90          |
| 12:41    | 1/17/94         |
| 12:45    | 5/2/93          |
| 12:46    | 5/2/93          |
| 12:47    | 5/2/93          |
| 12:48    | 5/2/93          |
| 12:49    | 5/2/93          |
| 12:51    | 6/30/91         |
| 12:56    | 9/26/90         |
| 12:57    | 9/26/90         |
| 12:58    | 9/26/90         |
| 12:60    | 3/21/93         |
| 12:90    | 12/17/89        |
| 12:100   | 11/5/89         |
| 12:105   | 1/21/91         |
| 12:110   | 1/19/93         |
| 12:112   | 9/6/93          |
| 12:120   | 5/3/90          |
| 12:175   | 11/28/93        |
| 12:190   | 1/4/93          |
| 12:195   | 6/24/93         |
| 12:200   | 8/5/90          |
| 12:210   | 9/6/93          |
| 12:235   | 5/5/91          |

**N.J.A.C.**

|        |          |
|--------|----------|
| 13:32  | 10/23/92 |
| 13:33  | 3/18/90  |
| 13:34  | 10/26/93 |
| 13:35  | 11/19/89 |
| 13:36  | 11/19/89 |
| 13:37  | 2/11/90  |
| 13:38  | 10/7/90  |
| 13:39  | 6/19/94  |
| 13:39A | 7/7/91   |
| 13:40  | 9/3/90   |
| 13:41  | 9/3/90   |
| 13:42  | 10/31/93 |
| 13:43  | 9/1/93   |
| 13:44  | 8/7/94   |
| 13:44B | 11/2/92  |
| 13:44C | 7/18/93  |
| 13:44D | 8/7/94   |
| 13:45A | 12/16/90 |
| 13:45B | 4/17/94  |
| 13:46  | 6/3/90   |
| 13:47  | 2/2/92   |
| 13:47A | 10/5/92  |
| 13:47B | 2/21/94  |
| 13:47C | 6/9/94   |
| 13:48  | 1/21/91  |
| 13:49  | 12/16/93 |
| 13:51  | 4/27/92  |
| 13:54  | 10/5/91  |
| 13:58  | 9/7/89   |
| 13:59  | 9/16/90  |
| 13:60  | 1/20/92  |
| 13:70  | 2/25/90  |
| 13:71  | 2/25/90  |
| 13:75  | 6/5/94   |
| 13:76  | 6/27/93  |
| 13:77  | 2/1/93   |
| 13:78  | 3/20/94  |

**Expiration Date****COMMERCE, ENERGY, AND ECONOMIC DEVELOPMENT—TITLE 12A**

| N.J.A.C.  | Expiration Date |
|-----------|-----------------|
| 12A:9     | 3/7/93          |
| 12A:10-1  | 8/15/89         |
| 12A:11    | 9/21/92         |
| 12A:12    | 9/21/92         |
| 12A:50    | 8/15/93         |
| 12A:54    | 8/15/93         |
| 12A:60    | 11/21/93        |
| 12A:80    | 2/6/94          |
| 12A:81    | 2/6/94          |
| 12A:82    | 2/6/94          |
| 12A:100-1 | 9/8/91          |
| 12A:120   | 9/6/93          |
| 12A:121   | 12/5/93         |

**PUBLIC UTILITIES—TITLE 14**

| N.J.A.C. | Expiration Date |
|----------|-----------------|
| 14:1     | 12/16/90        |
| 14:3     | 5/6/90          |
| 14:5     | 12/16/90        |
| 14:6     | 3/3/91          |
| 14:9     | 4/15/90         |
| 14:10    | 9/8/91          |
| 14:10-6  | 9/5/91          |
| 14:11    | 1/27/92         |
| 14:17    | 4/24/94         |
| 14:18    | 7/29/90         |

**LAW AND PUBLIC SAFETY—TITLE 13**

| N.J.A.C. | Expiration Date |
|----------|-----------------|
| 13:1     | 7/5/93          |
| 13:2     | 8/5/90          |
| 13:3     | 4/25/93         |
| 13:4     | 1/21/91         |
| 13:10    | 3/27/94         |
| 13:13    | 6/17/90         |
| 13:18    | 4/1/90          |
| 13:19    | 8/23/89         |
| 13:20    | 12/18/90        |
| 13:21    | 12/16/90        |
| 13:22    | 1/7/90          |
| 13:23    | 5/26/94         |
| 13:24    | 11/5/89         |
| 13:25    | 3/18/90         |
| 13:26    | 9/26/93         |
| 13:27    | 4/1/90          |
| 13:28    | 5/16/93         |
| 13:29    | 6/3/90          |
| 13:30    | 4/15/90         |
| 13:31    | 12/12/91        |

**ENERGY—TITLE 14A**

| N.J.A.C. | Expiration Date |
|----------|-----------------|
| 14A:2    | 4/17/89         |
| 14A:3    | 10/7/90         |
| 14A:5    | 10/19/88        |
| 14A:6    | 8/6/89          |
| 14A:7    | 9/16/90         |
| 14A:8    | 9/20/89         |
| 14A:11   | 9/20/89         |
| 14A:13   | 2/2/92          |
| 14A:14   | 1/30/94         |
| 14A:20   | 2/3/91          |
| 14A:21   | 11/21/90        |
| 14A:22   | 6/4/89          |

**STATE—TITLE 15**

| N.J.A.C. | Expiration Date |
|----------|-----------------|
| 15:2     | 5/2/93          |
| 15:3     | 7/7/91          |
| 15:5     | 2/17/92         |
| 15:10    | 2/18/91         |

**TRANSPORTATION—TITLE 16**

| N.J.A.C. | Expiration Date |
|----------|-----------------|
| 16:1     | 8/5/90          |
| 16:1A    | 6/16/94         |
| 16:5     | 3/6/94          |
| 16:6     | 8/7/94          |
| 16:7     | 3/6/94          |
| 16:13    | 5/7/89          |
| 16:20A   | 12/17/89        |
| 16:20B   | 12/17/89        |
| 16:21    | 9/3/90          |
| 16:21A   | 8/20/89         |
| 16:22    | 2/3/91          |
| 16:25    | 8/15/93         |
| 16:25A   | 7/18/93         |
| 16:26    | 9/5/94          |
| 16:27    | 9/8/91          |
| 16:28    | 6/1/93          |
| 16:28A   | 6/1/93          |
| 16:29    | 6/1/93          |
| 16:30    | 6/1/93          |
| 16:31    | 6/1/93          |
| 16:31A   | 6/1/93          |
| 16:32    | 4/15/90         |
| 16:33    | 9/3/90          |
| 16:41    | 7/28/92         |
| 16:41A   | 2/19/90         |
| 16:41B   | 3/4/90          |
| 16:43    | 9/3/90          |
| 16:44    | 5/25/93         |
| 16:49    | 3/18/90         |
| 16:51    | 4/6/92          |
| 16:53    | 7/17/94         |
| 16:53A   | 4/15/90         |
| 16:53B   | 7/3/94          |
| 16:53C   | 6/16/93         |
| 16:53D   | 5/3/94          |
| 16:54    | 4/7/91          |
| 16:55    | 6/14/93         |
| 16:56    | 8/7/94          |
| 16:60    | 6/14/93         |
| 16:61    | 6/14/93         |
| 16:62    | 4/15/90         |
| 16:72    | 3/31/91         |
| 16:73    | 1/30/92         |
| 16:75    | 5/13/93         |
| 16:76    | 2/6/94          |
| 16:77    | 1/21/90         |
| 16:78    | 10/7/90         |
| 16:79    | 10/20/91        |
| 16:80    | 11/7/93         |
| 16:81    | 11/7/93         |
| 16:82    | 9/5/94          |

**TREASURY-GENERAL—TITLE 17**

| N.J.A.C. | Expiration Date |
|----------|-----------------|
| 17:1     | 5/6/93          |
| 17:2     | 12/17/89        |
| 17:3     | 8/15/93         |
| 17:4     | 7/1/90          |
| 17:5     | 12/2/90         |
| 17:6     | 11/22/93        |
| 17:7     | 12/19/93        |
| 17:8     | 6/27/90         |
| 17:9     | 10/3/93         |
| 17:10    | 5/6/93          |
| 17:12    | 8/15/89         |
| 17:16    | 12/2/90         |
| 17:19    | 3/18/90         |
| 17:20    | 9/26/93         |
| 17:25    | 5/26/94         |
| 17:27    | 10/7/93         |

| N.J.A.C. | Expiration Date |
|----------|-----------------|
| 17:28    | 9/13/90         |
| 17:29    | 10/18/90        |
| 17:30    | 5/4/92          |
| 17:32    | 3/21/93         |
| 17:33    | 4/17/94         |

**TREASURY-TAXATION—TITLE 18**

| N.J.A.C. | Expiration Date |
|----------|-----------------|
| 18:1     | 7/21/94         |
| 18:2     | 9/6/93          |
| 18:3     | 3/14/94         |
| 18:5     | 3/14/94         |
| 18:6     | 3/14/94         |
| 18:7     | 3/14/94         |
| 18:8     | 2/24/94         |
| 18:9     | 6/7/93          |
| 18:12    | 7/29/93         |
| 18:12A   | 7/29/93         |
| 18:14    | 7/29/93         |
| 18:15    | 7/29/93         |
| 18:16    | 7/29/93         |
| 18:17    | 7/29/93         |
| 18:18    | 3/14/94         |
| 18:19    | 3/14/94         |
| 18:22    | 2/24/94         |
| 18:23    | 2/24/94         |
| 18:23A   | 8/5/90          |
| 18:24    | 6/7/93          |
| 18:25    | 1/6/91          |
| 18:26    | 6/7/93          |
| 18:30    | 4/2/89          |
| 18:35    | 6/7/93          |
| 18:36    | 2/4/90          |
| 18:37    | 8/5/90          |
| 18:38    | 2/16/93         |
| 18:39    | 9/8/92          |

**OTHER AGENCIES—TITLE 19**

| N.J.A.C. | Expiration Date           |
|----------|---------------------------|
| 19:3     | 5/26/93                   |
| 19:3B    | Exempt (N.J.S.A. 13:17-1) |
| 19:4     | 5/26/93                   |
| 19:4A    | 6/20/93                   |
| 19:8     | 7/5/93                    |
| 19:9     | 10/17/93                  |
| 19:10    | 9/5/94                    |
| 19:12    | 8/7/91                    |
| 19:16    | 8/7/91                    |
| 19:17    | 6/8/93                    |
| 19:25    | 1/9/91                    |
| 19:30    | 10/7/90                   |
| 19:40    | 9/26/89                   |
| 19:41    | 5/12/93                   |
| 19:42    | 5/12/93                   |
| 19:43    | 4/27/94                   |
| 19:44    | 9/29/93                   |
| 19:45    | 3/24/93                   |
| 19:46    | 4/28/93                   |
| 19:47    | 4/28/93                   |
| 19:48    | 10/13/93                  |
| 19:49    | 3/24/93                   |
| 19:50    | 5/12/93                   |
| 19:51    | 8/14/91                   |
| 19:52    | 9/25/91                   |
| 19:53    | 4/28/93                   |
| 19:54    | 3/24/93                   |
| 19:61    | 7/7/91                    |
| 19:65    | 7/7/91                    |
| 19:75    | 1/13/94                   |

# REGISTER INDEX OF RULE PROPOSALS AND ADOPTIONS

The research supplement to the New Jersey Administrative Code

## A CUMULATIVE LISTING OF CURRENT PROPOSALS AND ADOPTIONS

The **Register Index of Rule Proposals and Adoptions** is a complete listing of all active rule proposals (with the exception of rule changes proposed in this Register) and all new rules and amendments promulgated since the most recent update to the Administrative Code. Rule proposals in this issue will be entered in the Index of the next issue of the Register. **Adoptions promulgated in this Register have already been noted in the Index by the addition of the Document Number and Adoption Notice N.J.R. Citation next to the appropriate proposal listing.**

Generally, the key to locating a particular rule change is to find, under the appropriate Administrative Code Title, the N.J.A.C. citation of the rule you are researching. If you do not know the exact citation, scan the column of rule descriptions for the subject of your research. To be sure that you have found all of the changes, either proposed or adopted, to a given rule, scan the citations above and below that rule to find any related entries.

At the bottom of the index listing for each Administrative Code Title is the Transmittal number and date of the latest looseleaf update to that Title. Updates are issued monthly and include the previous month's adoptions, which are subsequently deleted from the Index. To be certain that you have a copy of all recent promulgations not yet issued in a Code update, retain each Register beginning with the July 3, 1989 issue.

If you need to retain a copy of all currently proposed rules, you must save the last 12 months of Registers. A proposal may be adopted up to one year after its initial publication in the Register. Failure to adopt a proposed rule on a timely basis requires the proposing agency to resubmit the proposal and to comply with the notice and opportunity-to-be-heard requirements of the Administrative Procedure Act (N.J.S.A. 52:14B-1 et seq.), as implemented by the Rules for Agency Rulemaking (N.J.A.C. 1:30) of the Office of Administrative Law. If an agency allows a proposed rule to lapse, "Expired" will be inserted to the right of the Proposal Notice N.J.R. Citation in the next Register following expiration. Subsequently, the entire proposal entry will be deleted from the Index. See: N.J.A.C. 1:30-4.2(c).

### Terms and abbreviations used in this Index:

**N.J.A.C. Citation.** The New Jersey Administrative Code numerical designation for each proposed or adopted rule entry.

**Proposal Notice (N.J.R. Citation).** The New Jersey Register page number and item identification for the publication notice and text of a proposed amendment or new rule.

**Document Number.** The Registry number for each adopted amendment or new rule on file at the Office of Administrative Law, designating the year of adoption of the rule and its chronological ranking in the Registry. As an example, R.1989 d.1 means the first rule adopted in 1989.

**Adoption Notice (N.J.R. Citation).** The New Jersey Register page number and item identification for the publication notice and text of an adopted amendment or new rule.

**Transmittal.** A series number and supplement date certifying the currency of rules found in each Title of the New Jersey Administrative Code: Rule adoptions published in the Register after the Transmittal date indicated do not yet appear in the loose-leaf volumes of the Code.

**N.J.R. Citation Locator.** An issue-by-issue listing of first and last pages of the previous 12 months of Registers. Use the locator to find the issue of publication of a rule proposal or adoption.

---

**MOST RECENT UPDATE TO THE ADMINISTRATIVE CODE: SUPPLEMENT JUNE 19, 1989**

**NEXT UPDATE: SUPPLEMENT JULY 17, 1989**

**Note: If no changes have occurred in a Title during the previous month, no update will be issued for that Title.**

# N.J.R. CITATION LOCATOR

| If the N.J.R. citation is<br>between: | Then the rule<br>proposal or<br>adoption appears<br>in this issue<br>of the Register | If the N.J.R. citation is<br>between: | Then the rule<br>proposal or<br>adoption appears<br>in this issue<br>of the Register |
|---------------------------------------|--|---------------------------------------|--|
| 20 N.J.R. 2123 and 2350               | September 6, 1988  | 21 N.J.R. 659 and 810                 | March 20, 1989   |
| 20 N.J.R. 2351 and 2416               | September 19, 1988   | 21 N.J.R. 811 and 954                 | April 3, 1989  |
| 20 N.J.R. 2417 and 2498               | October 3, 1988  | 21 N.J.R. 955 and 1036                | April 17, 1989   |
| 20 N.J.R. 2499 and 2610               | October 17, 1988   | 21 N.J.R. 1037 and 1178               | May 1, 1989  |
| 20 N.J.R. 2611 and 2842               | November 7, 1988   | 21 N.J.R. 1179 and 1474               | May 15, 1989   |
| 20 N.J.R. 2843 and 2948               | November 21, 1988  | 21 N.J.R. 1475 and 1598               | June 5, 1989   |
| 20 N.J.R. 2949 and 3046               | December 5, 1988   | 21 N.J.R. 1599 and 1762               | June 19, 1989  |
| 20 N.J.R. 3047 and 3182               | December 19, 1988  | 21 N.J.R. 1763 and 1934               | July 3, 1989   |
| 21 N.J.R. 1 and 88                    | January 3, 1989  | 21 N.J.R. 1935 and 2148               | July 17, 1989  |
| 21 N.J.R. 89 and 224                  | January 17, 1989   | 21 N.J.R. 2149 and 2426               | August 7, 1989   |
| 21 N.J.R. 225 and 364                 | February 6, 1989   | 21 N.J.R. 2427 and 2690               | August 21, 1989  |
| 21 N.J.R. 365 and 588                 | February 21, 1989  | 21 N.J.R. 2691 and 2842               | September 5, 1989  |
| 21 N.J.R. 589 and 658                 | March 6, 1989  |                                       |  |

| N.J.A.C.<br>CITATION              |   | PROPOSAL NOTICE<br>(N.J.R. CITATION) | DOCUMENT<br>NUMBER | ADOPTION NOTICE<br>(N.J.R. CITATION) |
|-----------------------------------|---|--------------------------------------|--------------------|--------------------------------------|
| <b>ADMINISTRATIVE LAW—TITLE 1</b> |   |                                      |                    |                                      |
| 1:1-8.2                           | Transmission of contested cases to OAL              | 21 N.J.R. 1181(a)                    | R.1989 d.395       | 21 N.J.R. 2019(a)                    |
| 1:1-14.11                         | Transcripts of OAL proceedings: pre-proposal        | 21 N.J.R. 1181(b)                    |                    |                                      |
| 1:10                              | Public welfare hearing rules: administrative change |                                      |                    | 21 N.J.R. 2288(a)                    |

**Most recent update to Title 1: TRANSMITTAL 1989-3 (supplement April 17, 1989)**

|                            |   |                   |              |                   |
|----------------------------|---|-------------------|--------------|-------------------|
| <b>AGRICULTURE—TITLE 2</b> |   |                   |              |                   |
| 2:3                        | Livestock and poultry importations  | 21 N.J.R. 1477(a) | R.1989 d.455 | 21 N.J.R. 2470(a) |
| 2:5                        | Equine infectious anemia and avian influenza                              | 21 N.J.R. 1479(a) | R.1989 d.454 | 21 N.J.R. 2472(a) |
| 2:24-2.1                   | Over-wintering of bees  | 20 N.J.R. 2951(a) |              |                   |
| 2:34-2                     | Equine Advisory Board rules   | 21 N.J.R. 2151(a) |              |                   |
| 2:76                       | State Agricultural Development Committee rules                            | 21 N.J.R. 1601(a) | R.1989 d.453 | 21 N.J.R. 2472(b) |
| 2:76-3.12                  | Farmland preservation programs: deed restrictions                         | 21 N.J.R. 1183(a) | R.1989 d.451 | 21 N.J.R. 2472(c) |
| 2:76-4.11                  | Municipally-approved farmland preservation programs:<br>deed restrictions | 21 N.J.R. 1183(b) | R.1989 d.452 | 21 N.J.R. 2473(a) |
| 2:76-6.16                  | Farmland Preservation Program: easement purchase<br>evaluation criteria   | 21 N.J.R. 2152(a) |              |                   |

**Most recent update to Title 2: TRANSMITTAL 1989-6 (supplement June 19, 1989)**

|   |  |                               |              |                   |
|---|--|-------------------------------|--------------|-------------------|
| <b>BANKING—TITLE 3</b>                          |  |                               |              |                   |
| 3:1-2.25, 2.26                                  | Filing and application fees for banks, savings banks,<br>and savings and loan associations | 21 N.J.R. 1601(b)             | R.1989 d.449 | 21 N.J.R. 2473(b) |
| 3:1-2.25, 2.26                                  | DOB application fees   | Emergency (expires<br>9-1-89) | R.1989 d.406 | 21 N.J.R. 2397(a) |
| 3:1-6.1, 6.2, 7.1, 7.2,<br>7.4, 7.5, 9.6        | DOB fees for services  | Emergency (expires<br>9-1-89) | R.1989 d.407 | 21 N.J.R. 2398(a) |
| 3:6-13.3, 13.5, 14.1,<br>14.2                   | Filing and application fees for banks, savings banks,<br>and savings and loan associations | 21 N.J.R. 1601(b)             | R.1989 d.449 | 21 N.J.R. 2473(c) |
| 3:6-13.3, 13.5, 14.1,<br>14.2                   | DOB application fees   | Emergency (expires<br>9-1-89) | R.1989 d.406 | 21 N.J.R. 2397(a) |
| 3:11-5.1, 11.9                                  | Filing and application fees for banks, savings banks,<br>and savings and loan associations | 21 N.J.R. 1601(b)             | R.1989 d.449 | 21 N.J.R. 2473(c) |
| 3:11-5.1, 11.9                                  | DOB application fees   | Emergency (expires<br>9-1-89) | R.1989 d.406 | 21 N.J.R. 2397(a) |
| 3:13-3.2  | DOB fees for services  | Emergency (expires<br>9-1-89) | R.1989 d.407 | 21 N.J.R. 2398(a) |
| 3:17-2.1, 2.2, 3.9, 6.1,<br>6.2, 6.6, 6.10, 7.1 | Consumer Loan Act rules  | Emergency (expires<br>9-1-89) | R.1989 d.408 | 21 N.J.R. 2399(a) |
| 3:18-10.1                                       | License fees   | Emergency (expires<br>9-1-89) | R.1989 d.409 | 21 N.J.R. 2401(a) |
| 3:19-1.7  | DOB fees for services  | Emergency (expires<br>9-1-89) | R.1989 d.407 | 21 N.J.R. 2398(a) |
| 3:23-2.1  | License fees   | Emergency (expires<br>9-1-89) | R.1989 d.409 | 21 N.J.R. 2401(a) |
| 3:24  | Check cashing business standards   | 21 N.J.R. 1765(a)             |              |                   |
| 3:24-5.1  | Check cashing facilities: administrative correction  |                               |              | 21 N.J.R. 2784(a) |
| 3:33-1  | Proposed interstate acquisition: determination of<br>eligibility                           | 21 N.J.R. 814(a)              |              |                   |
| 3:38-1.1, 1.2                                   | License fees   | Emergency (expires<br>9-1-89) | R.1989 d.409 | 21 N.J.R. 2401(a) |

| N.J.A.C. CITATION |                       | PROPOSAL NOTICE (N.J.R. CITATION) | DOCUMENT NUMBER | ADOPTION NOTICE (N.J.R. CITATION) |
|-------------------|-----------------------|-----------------------------------|-----------------|-----------------------------------|
| 3:38-1.8          | DOB fees for services | Emergency (expires 9-1-89)        | R.1989 d.407    | 21 N.J.R. 2398(a)                 |

**Most recent update to Title 3: TRANSMITTAL 1989-3 (supplement June 19, 1989)**

**CIVIL SERVICE—TITLE 4**

|                       |   |                   |              |                   |
|-----------------------|---|-------------------|--------------|-------------------|
| 4:1-16.1-16.6, 24.2   | Repeal (see 4A:8)   | 20 N.J.R. 2955(b) |              |                   |
| 4:1-16.6, 16.15, 25.1 | Repeal rules  | 21 N.J.R. 1766(a) |              |                   |
| 4:2-7.7(c)            | Repeal (see 4A:3-4.11)  | 21 N.J.R. 1184(a) |              |                   |
| 4:2-16.1, 16.2        | Repeal (see 4A:8)   | 20 N.J.R. 2955(b) |              |                   |
| 4:2-16.6, 16.8        | Repeal rules  | 21 N.J.R. 1766(a) |              |                   |
| 4:3-16                | Layoffs in local service  | 21 N.J.R. 1185(a) | R.1989 d.369 | 21 N.J.R. 2019(b) |
| 4:3-16                | Layoffs in local service: waiver of Executive Order No. 66(1978) expiration provision | 21 N.J.R. 1480(a) |              |                   |
| 4:3-16.1, 16.2        | Repeal (see 4A:8)   | 20 N.J.R. 2955(b) |              |                   |

**Most recent update to Title 4: TRANSMITTAL 1988-3 (supplement September 19, 1988)**

**PERSONNEL—TITLE 4A**

|  |  |                   |       |                   |
|--|--|-------------------|-------|-------------------|
| 4A:1-4.1                               | Delegation approval in local service                       | 21 N.J.R. 1766(a) |       |                   |
| 4A:2-1.2, 1.4, 2.5, 2.7, 3.1, 3.7      | Appeals and discipline                                     | 21 N.J.R. 1766(a) |       |                   |
| 4A:3-2.2                               | Designation of SES positions: administrative correction    | _____             | _____ | 21 N.J.R. 1824(a) |
| 4A:3-4.11                              | State service: downward title reevaluation pay adjustments | 21 N.J.R. 1184(a) |       |                   |
| 4A:3-4.17, 4.21                        | Compensation: State service                                | 21 N.J.R. 2429(a) |       |                   |
| 4A:4-2.1, 2.15, 3.4, 5.5               | Promotional examinations; eligible lists                   | 21 N.J.R. 2429(a) |       |                   |
| 4A:4-2.3, 2.9, 2.15, 5.2, 6.3-6.6, 7.3 | Selection and appointment                                  | 21 N.J.R. 1766(a) |       |                   |
| 4A:6-1.5                               | Sick leave: State service                                  | 21 N.J.R. 2429(a) |       |                   |
| 4A:8                                   | Layoffs  | 20 N.J.R. 2955(b) |       |                   |
| 4A:8                                   | Layoffs: change of public hearing dates                    | 20 N.J.R. 3171(a) |       |                   |
| 4A:10-1.1                              | Information requested of appointing authority              | 21 N.J.R. 2429(a) |       |                   |
| 4A:10-2.2                              | Vacated position and permanent appointment                 | 21 N.J.R. 1766(a) |       |                   |

**Most recent update to Title 4A: TRANSMITTAL 1989-1 (supplement January 17, 1989)**

**COMMUNITY AFFAIRS—TITLE 5**

|   |   |                            |              |                   |
|---|---|----------------------------|--------------|-------------------|
| 5:11-8.5  | Recovery of relocation assistance costs   | 21 N.J.R. 1039(a)          | R.1989 d.402 | 21 N.J.R. 2288(b) |
| 5:14-4  | Neighborhood Preservation Balanced Housing Program: affordability controls                        | 21 N.J.R. 2153(a)          |              |                   |
| 5:15-3.1, 3.4   | Emergency shelters for homeless   | 21 N.J.R. 1509(a)          | R.1989 d.412 | 21 N.J.R. 2288(c) |
| 5:18-1.4, 1.5, 2.4A, 2.5, 2.7, 2.8, 4.1, 4.7, 4.9, 4.11, 4.13 | Uniform Fire Code inspection, safety and enforcement provisions                                   | 21 N.J.R. 2431(a)          |              |                   |
| 5:18-2.7  | Uniform Fire Code and Building Subcode: tents and tensioned membrane structures requiring permits | 21 N.J.R. 1654(a)          |              |                   |
| 5:18-2.8  | Uniform Fire Code: life hazard use registration fees and permit fees                              | Emergency (expires 9-1-89) | R.1989 d.404 | 21 N.J.R. 2126(a) |
| 5:18-2.8  | Uniform Fire Code: correction to fee schedule   | _____                      | _____        | 21 N.J.R. 2402(a) |
| 5:18A-2.6   | Fire Code Enforcement: fee collection remittance  | Emergency (expires 9-1-89) | R.1989 d.404 | 21 N.J.R. 2126(a) |
| 5:18A-3.3   | Duties of fire officials  | 21 N.J.R. 2431(a)          |              |                   |
| 5:18A-4   | Repeal (see 5:18C)  | 21 N.J.R. 1655(a)          |              |                   |
| 5:18C   | Uniform Fire Code: fire service training and certification  | 21 N.J.R. 1655(a)          |              |                   |
| 5:23-2.18A  | Utility load management devices: installation programs  | 21 N.J.R. 233(a)           |              |                   |
| 5:23-2.18A  | Utility load management devices: public hearing concerning installation programs                  | 21 N.J.R. 1185(b)          |              |                   |
| 5:23-3.14   | Uniform Fire Code and Building Subcode: tents and tensioned membrane structures requiring permits | 21 N.J.R. 1654(a)          |              |                   |
| 5:23-4.3  | Uniform Construction Code: assumption of local enforcement powers                                 | 20 N.J.R. 1764(a)          | R.1989 d.435 | 21 N.J.R. 2474(a) |
| 5:23-4.3  | UCC: assumption of local enforcement powers   | 21 N.J.R. 2436(a)          |              |                   |
| 5:23-4.17, 4.18, 4.19, 4.20                                   | Uniform Construction Code: municipal and departmental fees  | Emergency (expires 9-1-89) | R.1989 d.405 | 21 N.J.R. 2127(a) |
| 5:23-4.24A  | Uniform Construction Code: alternative plan review program for large projects                     | 21 N.J.R. 1770(a)          |              |                   |
| 5:23-8  | Asbestos Hazard Abatement Subcode   | 20 N.J.R. 1130(b)          | R.1989 d.342 | 21 N.J.R. 1844(b) |
| 5:26-2.3, 2.4   | Planned real estate development full disclosure: registration and exemption fees                  | Emergency (expires 9-1-89) | R.1989 d.405 | 21 N.J.R. 2127(a) |
| 5:27-3.3  | Rooming and boarding houses: emergency eviction of a resident                                     | 21 N.J.R. 93(a)            |              |                   |
| 5:52-1  | Volunteer coaches' safety orientation and training skills programs: minimum standards             | 21 N.J.R. 2159(a)          |              |                   |
| 5:70-6.3  | Congregate Housing Services Program: service subsidies formula                                    | 21 N.J.R. 816(a)           | R.1989 d.393 | 21 N.J.R. 2019(c) |

| N.J.A.C. CITATION           |  | PROPOSAL NOTICE (N.J.R. CITATION) | DOCUMENT NUMBER | ADOPTION NOTICE (N.J.R. CITATION) |
|-----------------------------|--|-----------------------------------|-----------------|-----------------------------------|
| 5:80-6.1, 6.5, 6.6          | Housing and Mortgage Finance Agency: sale of project by nonprofit sponsor to for-profit sponsor; use of DCE/CDE accounts | 21 N.J.R. 1509(b)                 |                 |                                   |
| 5:80-9.13                   | Housing and Mortgage Finance Agency: notice of rent increases  | 21 N.J.R. 2160(a)                 |                 |                                   |
| 5:91-1.2, 4.5, 6.2, 7.1-7.6 | Council on Affordable Housing: mediation and post mediation process  | 21 N.J.R. 1773(a)                 |                 |                                   |
| 5:92-1.3, 12                | Council on Affordable Housing: controls on affordability   | 21 N.J.R. 592(b)                  | R.1989 d.370    | 21 N.J.R. 2020(a)                 |
| 5:92-8.4                    | Council on Affordable Housing: developer agreements  | 21 N.J.R. 1185(c)                 |                 |                                   |
| 5:92-12.3                   | Option to buy sales units: administrative correction   | _____                             | _____           | 21 N.J.R. 2475(a)                 |
| 5:92-12 App.                | Uniform deed restrictions and lines: controls on affordability   | 21 N.J.R. 1988(a)                 |                 |                                   |
| 5:92-18                     | Council on Affordable Housing: municipal conformance with State Development and Redevelopment Plan                       | 21 N.J.R. 1186(a)                 |                 |                                   |
| 5:100                       | Ombudsman for institutionalized elderly: practice and procedure  | 21 N.J.R. 1510(a)                 |                 |                                   |
| 5:100                       | Ombudsman practice and procedure: extension of comment period  | 21 N.J.R. 1995(a)                 |                 |                                   |

Most recent update to Title 5: TRANSMITTAL 1989-6 (supplement June 19, 1989)

#### MILITARY AND VETERANS' AFFAIRS (formerly DEFENSE)—TITLE 5A

Most recent update to Title 5A: TRANSMITTAL 1 (supplement May 20, 1985)

#### EDUCATION—TITLE 6

|                         |   |                   |              |                   |
|-------------------------|---|-------------------|--------------|-------------------|
| 6:3-6                   | Enforcement of drug free school zones   | 21 N.J.R. 817(a)  | R.1989 d.354 | 21 N.J.R. 1824(b) |
| 6:8-9                   | Elementary and secondary school summer sessions                                 | 21 N.J.R. 2441(c) |              |                   |
| 6:11-3                  | Bilingual/ESL certification; basic communication skills certification           | 21 N.J.R. 95(a)   |              |                   |
| 6:24-5.4                | Tenure charges against persons within Human Services, Corrections and Education | 21 N.J.R. 1939(b) |              |                   |
| 6:26                    | Repeal (see 6:8-9)  | 21 N.J.R. 2441(c) |              |                   |
| 6:27                    | Repeal (see 6:8-9)  | 21 N.J.R. 2441(c) |              |                   |
| 6:28-4.5                | Special education home instruction: administrative correction                   | _____             | _____        | 21 N.J.R. 2288(d) |
| 6:29-9.2, 9.3, 9.5, 9.6 | Substance abuse control and education   | 21 N.J.R. 1603(a) | R.1989 d.480 | 21 N.J.R. 2784(b) |
| 6:30-1.7, 2.3, 2.6      | Adult education programs: monitoring and funding                                | 21 N.J.R. 1039(b) | R.1989 d.355 | 21 N.J.R. 1826(a) |
| 6:30-2.3                | Adult education: administrative correction                                      | _____             | _____        | 21 N.J.R. 2475(b) |
| 6:31                    | Bilingual education   | 21 N.J.R. 2443(a) |              |                   |
| 6:39-1                  | Statewide assessment of pupil proficiency in core studies                       | 21 N.J.R. 1605(a) | R.1989 d.479 | 21 N.J.R. 2786(a) |
| 6:70                    | Library network services  | 21 N.J.R. 1940(a) |              |                   |

Most recent update to Title 6: TRANSMITTAL 1989-5 (supplement May 15, 1989)

#### ENVIRONMENTAL PROTECTION—TITLE 7

|  |  |                   |              |                   |
|--|--|-------------------|--------------|-------------------|
| 7:0  | DEP rulemaking agenda  | _____             | _____        | 21 N.J.R. 1911(c) |
| 7:1-1.2                                    | Petition for rulemaking procedure  | 21 N.J.R. 102(a)  | R.1989 d.419 | 21 N.J.R. 2302(a) |
| 7:1-1.2                                    | Petition for rulemaking procedure: extension of comment period                       | 21 N.J.R. 1289(a) |              |                   |
| 7:1C-1.2-1.5, 1.7-1.9, 1.13, 1.14          | 90-day construction permits  | 21 N.J.R. 819(a)  | R.1989 d.436 | 21 N.J.R. 2530(a) |
| 7:1G                                       | Worker and Community Right to Know   | 21 N.J.R. 1944(a) |              |                   |
| 7:1I-3.3                                   | Sanitary Landfill Contingency Fund: appraisal of residential properties              | _____             | _____        | 21 N.J.R. 1911(b) |
| 7:2-11.12                                  | Natural Areas System: West Pine Plains   | 21 N.J.R. 1480(b) |              |                   |
| 7:2-11.12                                  | Designation of West Pine Plains to Natural Areas System: extension of comment period | 21 N.J.R. 2240(b) |              |                   |
| 7:4A                                       | Historic Preservation Grant Program  | 21 N.J.R. 958(c)  |              |                   |
| 7:6  | Boating rules  | 21 N.J.R. 1157(a) | R.1989 d.351 | 21 N.J.R. 1856(a) |
| 7:6-1.44, 4.7, 9                           | Lanyard cut-off switch; Greenwood Lake boating; personal watercraft                  | 21 N.J.R. 1157(b) | R.1989 d.352 | 21 N.J.R. 1856(b) |
| 7:7A-1.4, 2.5, 6, 7, 16.6, 16.7            | Freshwater wetlands transition areas   | 21 N.J.R. 596(a)  | R.1989 d.362 | 21 N.J.R. 1858(a) |
| 7:7A-9.2, 9.4                              | Freshwater wetlands protection: Statewide general permits for certain activities     | 20 N.J.R. 1327(a) | R.1989 d.373 | 21 N.J.R. 2024(a) |
| 7:7E-7.14                                  | High rise structures: administrative correction                                      | _____             | _____        | 21 N.J.R. 1857(a) |
| 7:9-2                                      | Repeal (see 7:9A)  | 20 N.J.R. 1790(a) | R.1989 d.450 | 21 N.J.R. 2534(a) |
| 7:9-4                                      | Surface water quality standards: public hearings                                     | 20 N.J.R. 1865(a) |              |                   |
| 7:9-4                                      | Surface water quality standards: extension of comment period                         | 20 N.J.R. 2427(a) |              |                   |
| 7:9-4.4, 4.5, 4.6, 4.14, 4.15, Indexes A-G | Surface water quality standards  | 20 N.J.R. 1597(a) | R.1989 d.420 | 21 N.J.R. 2302(b) |
| 7:9A                                       | Individual subsurface sewage disposal systems  | 20 N.J.R. 1790(a) | R.1989 d.450 | 21 N.J.R. 2534(a) |
| 7:9A                                       | Individual subsurface sewage disposal systems: extension of comment period           | 20 N.J.R. 2427(b) |              |                   |
| 7:10                                       | Safe Drinking Water Act  | 21 N.J.R. 1945(a) |              |                   |

| N.J.A.C. CITATION   |  | PROPOSAL NOTICE (N.J.R. CITATION) | DOCUMENT NUMBER | ADOPTION NOTICE (N.J.R. CITATION) |
|---|--|-----------------------------------|-----------------|-----------------------------------|
| 7:12-1.1, 2.1, 3.2, 4.1, 4.2, 5.1, 9.1, 9.7, 9.8, 9.9, 9.12                           | Shellfish-growing water classification   | 21 N.J.R. 1041(b)                 | R.1989 d.390    | 21 N.J.R. 2032(a)                 |
| 7:13  | Flood hazard area control  | 21 N.J.R. 371(a)                  | R.1989 d.415    | 21 N.J.R. 2350(a)                 |
| 7:13  | Flood hazard area control: extension of comment period                                 | 21 N.J.R. 1046(a)                 |                 |                                   |
| 7:13  | Flood Hazard Area Control: waiver of Executive Order No. 66(1978) expiration provision | 21 N.J.R. 1481(a)                 |                 |                                   |
| 7:13-7.1(d)   | Redelineation of Bound Brook within South Plainfield and Edison                        | 20 N.J.R. 3051(b)                 |                 |                                   |
| 7:13-7.1(d)   | Redelineation of West Branch Rahway River, West Orange                                 | 21 N.J.R. 605(a)                  | R.1989 d.445    | 21 N.J.R. 2672(a)                 |
| 7:13-7.1(d)   | Redelineation of Ramapo River in Mahwah  | 21 N.J.R. 1046(b)                 | R.1989 d.446    | 21 N.J.R. 2671(a)                 |
| 7:13-7.1(d)   | Redelineation of Ramapo River: extension of comment period                             | 21 N.J.R. 1482(a)                 |                 |                                   |
| 7:14A   | New Jersey Pollutant Discharge Elimination System (NJPDDES)                            | 21 N.J.R. 707(a)                  | R.1989 d.339    | 21 N.J.R. 1883(a)                 |
| 7:14A-4.7   | Hazardous waste management: polychlorinated biphenyls (PCBs)                           | 21 N.J.R. 1047(a)                 |                 |                                   |
| 7:14A-12.22, 12.23  | Sewer connection ban exemptions  | 21 N.J.R. 2240(c)                 |                 |                                   |
| 7:14B-1.3, 1.4, 1.6, 2.1-2.5, 2.7, 2.8, 3.1, 3.2, 3.4, 3.5, 4-12, 15                  | Underground storage tank systems   | 21 N.J.R. 2242(a)                 |                 |                                   |
| 7:14B-13  | Underground Storage Tank Improvement Fund loan program                                 | 21 N.J.R. 2265(a)                 |                 |                                   |
| 7:15  | Statewide water quality management planning  | 20 N.J.R. 2198(a)                 |                 |                                   |
| 7:15-3.4  | Correction to proposed new rule  | 20 N.J.R. 2478(a)                 |                 |                                   |
| 7:19-6.10(c), (d)2  | Reduction of privilege to withdraw water: notice of rule invalidity                    |                                   |                 | 21 N.J.R. 2786(b)                 |
| 7:22A-1, 2, 3, 6  | Sewage Infrastructure Improvement Act grants   | 21 N.J.R. 1948(a)                 |                 |                                   |
| 7:23  | Emergency flood control  | 21 N.J.R. 1051(a)                 | R.1989 d.348    | 21 N.J.R. 1903(a)                 |
| 7:25-1.5, 24  | Leasing of Atlantic Coast bottom for aquaculture                                       | 21 N.J.R. 1482(b)                 |                 |                                   |
| 7:25-5  | 1989-1990 Game Code  | 21 N.J.R. 1289(b)                 | R.1989 d.418    | 21 N.J.R. 2356(a)                 |
| 7:25-6  | 1990-1991 Fish Code  | 21 N.J.R. 1775(b)                 |                 |                                   |
| 7:25-22.1-22.4  | Harvesting Atlantic menhaden   | 21 N.J.R. 107(a)                  | R.1989 d.394    | 21 N.J.R. 2035(a)                 |
| 7:26-1.4, 7.4, 7.7, 8.2, 8.3, 8.4, 8.13, 9.1, 9.2, 10.6, 10.7, 10.8, 11.3, 11.4, 12.1 | Hazardous waste management: polychlorinated biphenyls (PCBs)                           | 21 N.J.R. 1047(a)                 |                 |                                   |
| 7:26-3A   | Regulated medical wastes   | Emergency (expires 8-25-89)       | R.1989 d.396    | 21 N.J.R. 2109(a)                 |
| 7:26-6.5  | Interdistrict and intradistrict solid waste flow: Bergen County                        | 21 N.J.R. 1486(b)                 |                 |                                   |
| 7:26-8.2, 12.3  | Radioactive mixed wastes   | 21 N.J.R. 1053(a)                 |                 |                                   |
| 7:26-9.10, 9.13, App. A   | Hazardous waste facility liability coverage: corporate guarantee option                | 21 N.J.R. 823(a)                  |                 |                                   |
| 7:26-10.6, 11.3   | Interim status hazardous waste facilities: closure and post-closure requirements       | 21 N.J.R. 1054(a)                 |                 |                                   |
| 7:26-16.5, 16.13  | Solid and hazardous waste operations: licensing of individuals                         | 21 N.J.R. 2275(a)                 |                 |                                   |
| 7:26B-1.3, 1.5, 1.6, 1.7, 1.8, 1.9, 3.3, 5.2, 7.5, 9.2, 10.1, 13.1                    | Environmental Cleanup Responsibility Act rules   | 21 N.J.R. 402(a)                  | R.1989 d.403    | 21 N.J.R. 2367(a)                 |
| 7:27-16.3   | Vapor control during marine transfer operations  | 21 N.J.R. 1960(a)                 |                 |                                   |
| 7:27-23.2, 23.3, 23.4, 23.5   | Volatile organic substances in consumer products                                       | 21 N.J.R. 1055(a)                 |                 |                                   |
| 7:27A-3   | Air pollution control: civil administrative penalties and adjudicatory hearings        | 21 N.J.R. 729(a)                  |                 |                                   |
| 7:28-25   | Radiation laboratory fee schedule  | 21 N.J.R. 826(a)                  | R.1989 d.349    | 21 N.J.R. 1904(a)                 |
| 7:45-1.2, 1.3, 2.6, 2.11, 4.1, 6, 9, 11.1-11.5  | Delaware and Raritan Canal State Park review zone rules                                | 21 N.J.R. 828(a)                  |                 |                                   |

Most recent update to Title 7: TRANSMITTAL 1989-6 (supplement June 19, 1989)

#### HEALTH—TITLE 8

|            |   |                   |              |                   |
|------------|---|-------------------|--------------|-------------------|
| 8:18       | Catastrophic Illness in Children Relief Fund Program                    | 21 N.J.R. 1781(a) |              |                   |
| 8:31-30    | Health care facility construction: plan review fee (recodify as 8:31-1) | 21 N.J.R. 2447(a) |              |                   |
| 8:31B-3.16 | Hospital reimbursement: labor cost component                            | 21 N.J.R. 661(b)  | R.1989 d.383 | 21 N.J.R. 2087(a) |

| <b>N.J.A.C. CITATION</b>  |   | <b>PROPOSAL NOTICE (N.J.R. CITATION)</b> | <b>DOCUMENT NUMBER</b> | <b>ADOPTION NOTICE (N.J.R. CITATION)</b> |
|---|---|--|------------------------|--|
| 8:31B-3.16, 3.22, 3.24, 3.26, 3.38, 3.51-3.55, 3.58, 3.59, 3.73, App. II, IX, 5.1-5.3 | Hospital reimbursement: extension of comment period for proposed changes published January 17, 1989               | 21 N.J.R. 606(a)                         |                        |  |
| 8:31B-3.16, 3.22, 3.24, 3.26, 3.38, 3.73, App. II, IX                                 | Hospital reimbursement: 1989 rate setting   | 21 N.J.R. 135(a)                         | R. 1989 d.387          | 21 N.J.R. 2058(a)                        |
| 8:31B-3.16, 3.22, 3.24, 3.26, 3.38, 3.73, App. II, IX                                 | 1989 hospital rate setting: correction to Summary statement   | 21 N.J.R. 413(a)                         |                        |  |
| 8:31B-3.22, 3.23, 3.24, App. XI   | Hospital reimbursement: graduate medical education  | 21 N.J.R. 1059(a)                        | R. 1989 d.388          | 21 N.J.R. 2082(a)                        |
| 8:31B-3.24  | Hospital reimbursement: administrative correction   | _____                                    | _____                  | 21 N.J.R. 2475(c)                        |
| 8:31B-3.27  | Capital facilities: administrative correction   | _____                                    | _____                  | 21 N.J.R. 1827(a)                        |
| 8:31B-3.51-3.55, 3.58, 3.59, 3.60   | Hospital reimbursement: appeals   | 21 N.J.R. 131(b)                         | R. 1989 d.385          | 21 N.J.R. 2073(a)                        |
| 8:31B-3.66  | Hospital reimbursement: adjusted admission fee ceiling  | 21 N.J.R. 1606(a)                        | R. 1989 d.472          | 21 N.J.R. 2787(a)                        |
| 8:31B-3.73  | Hospital reimbursement: rates adjustment and reconciliation   | 21 N.J.R. 1606(b)                        | R. 1989 d.471          | 21 N.J.R. 2787(b)                        |
| 8:31B-4.15  | Hospital reimbursement: uniform uncompensated care add-on   | 21 N.J.R. 1487(a)                        |                        |  |
| 8:31B-4.37, 7.3   | Reinsurance Program and charity care; Statewide uncompensated care add-on   | 21 N.J.R. 2448(a)                        |                        |  |
| 8:31B-4.38-4.40   | Hospital reimbursement: uncompensated care  | 21 N.J.R. 2449(a)                        |                        |  |
| 8:31B-4.62  | Hospital reimbursement: MICU services   | 21 N.J.R. 2453(a)                        |                        |  |
| 8:31B-5.1, 5.2, 5.3   | Hospital reimbursement: Diagnosis Related Groups  | 21 N.J.R. 138(a)                         | R. 1989 d.384          | 21 N.J.R. 2088(a)                        |
| 8:31B-5.3   | Hospital reimbursement: administrative correction   | _____                                    | _____                  | 21 N.J.R. 2476(a)                        |
| 8:31B-7.9   | Uncompensated Care Trust Fund cap   | 21 N.J.R. 1487(b)                        |                        |  |
| 8:31C-1.2, 1.3, 1.4, 1.6, 1.12, 1.17  | Residential alcoholism treatment facilities: rate setting and reimbursement                                       | 21 N.J.R. 2454(a)                        |                        |  |
| 8:33C   | Perinatal services: Certificate of Need review process  | 21 N.J.R. 1187(a)                        | R. 1989 d.417          | 21 N.J.R. 2289(a)                        |
| 8:33G   | Computerized tomography services: certificate of need process   | 21 N.J.R. 1061(a)                        | R. 1989 d.416          | 21 N.J.R. 2289(b)                        |
| 8:33L-1.2, 2.1, 2.2, 2.4, 2.6, 2.7  | Home health agency services   | 21 N.J.R. 2455(a)                        |                        |  |
| 8:33M   | Rehabilitation hospitals and comprehensive rehabilitation services: need review process                           | 21 N.J.R. 1062(a)                        | R. 1989 d.386          | 21 N.J.R. 2102(a)                        |
| 8:39-19.7   | Hot water temperature in long-term care facilities  | 21 N.J.R. 417(a)                         | R. 1989 d.389          | 21 N.J.R. 2107(a)                        |
| 8:39-29.4   | Licensed nursing homes: non-prescription medications  | 21 N.J.R. 1607(a)                        |                        |  |
| 8:43B-11.1, 11.3, 11.4  | Rehabilitation hospitals: standards for licensure   | 21 N.J.R. 1067(a)                        | R. 1989 d.432          | 21 N.J.R. 2476(b)                        |
| 8:43E-3   | Adult closed acute psychiatric beds: certification of need  | 21 N.J.R. 1785(a)                        |                        |  |
| 8:43E-4.5   | Child and adolescent acute psychiatric beds: need formula   | 21 N.J.R. 2459(a)                        |                        |  |
| 8:43G-3   | Hospital licensure: compliance with mandatory rules and advisory standards  | 21 N.J.R. 1608(a)                        |                        |  |
| 8:43G-4   | Hospital licensure: patient rights  | 21 N.J.R. 2160(a)                        |                        |  |
| 8:43G-7   | Hospital licensure: cardiac services  | 21 N.J.R. 2162(a)                        |                        |  |
| 8:43G-8   | Hospital licensure: central supply  | 21 N.J.R. 1609(a)                        |                        |  |
| 8:43G-9   | Hospital licensure: critical and intermediate care  | 21 N.J.R. 2167(a)                        |                        |  |
| 8:43G-10  | Hospital licensure: dietary standard  | 21 N.J.R. 1611(a)                        |                        |  |
| 8:43G-11  | Hospital licensure: discharge planning  | 21 N.J.R. 1612(a)                        |                        |  |
| 8:43G-12  | Hospital licensure: emergency department  | 21 N.J.R. 1613(a)                        |                        |  |
| 8:43G-13  | Hospital licensure: housekeeping and laundry  | 21 N.J.R. 1616(a)                        |                        |  |
| 8:43G-14  | Hospital licensure: infection control and sanitation  | 21 N.J.R. 1618(a)                        |                        |  |
| 8:43G-15  | Hospital licensure: medical records   | 21 N.J.R. 2171(a)                        |                        |  |
| 8:43G-16  | Hospital licensure: medical staff standard  | 21 N.J.R. 1621(a)                        |                        |  |
| 8:43G-17  | Hospital licensure: nurse staffing  | 21 N.J.R. 1623(a)                        |                        |  |
| 8:43G-18  | Hospital licensure: nursing care  | 21 N.J.R. 1624(a)                        |                        |  |
| 8:43G-20  | Hospital licensure: employee health   | 21 N.J.R. 2173(a)                        |                        |  |
| 8:43G-23  | Hospital licensure: pharmacy  | 21 N.J.R. 1626(a)                        |                        |  |
| 8:43G-25  | Hospital licensure: post mortem standard  | 21 N.J.R. 1628(a)                        |                        |  |
| 8:43G-27  | Hospital licensure: quality assurance   | 21 N.J.R. 1630(a)                        |                        |  |
| 8:43G-28  | Hospital licensure: radiology   | 21 N.J.R. 2174(a)                        |                        |  |
| 8:43G-32, 34  | Hospital licensure: same-day stay; surgery  | 21 N.J.R. 2177(a)                        |                        |  |
| 8:43G-33  | Hospital licensure: social work   | 21 N.J.R. 1631(a)                        |                        |  |
| 8:43H   | Rehabilitation hospitals: standards for licensure   | 21 N.J.R. 1067(a)                        | R. 1989 d.432          | 21 N.J.R. 2476(b)                        |
| 8:43H-23, 24  | Licensure of comprehensive rehabilitation hospitals: physical plant; functional requirements                      | 21 N.J.R. 1188(a)                        | R. 1989 d.433          | 21 N.J.R. 2494(a)                        |
| 8:59  | Worker and Community Right to Know Act rules  | 21 N.J.R. 1253(a)                        |                        |  |
| 8:59-App. A, B  | Worker and Community Right to Know: preproposed Hazardous Substance List and Special Health Hazard Substance List | 21 N.J.R. 1194(a)                        |                        |  |
| 8:70-1.5  | Interchangeable drug products: substitution of unlisted generics  | 20 N.J.R. 2623(a)                        |                        |  |

| N.J.A.C. CITATION |   | PROPOSAL NOTICE (N.J.R. CITATION) | DOCUMENT NUMBER | ADOPTION NOTICE (N.J.R. CITATION) |
|-------------------|---|-----------------------------------|-----------------|-----------------------------------|
| 8:71              | Interchangeable drug products (see 20 N.J.R. 2769(a); 21 N.J.R. 63(b), 756(b), 1430(a)) | 20 N.J.R. 1766(a)                 | R.1989 d.377    | 21 N.J.R. 2107(b)                 |
| 8:71              | Interchangeable drug products (see 21 N.J.R. 63(c), 756(a), 1429(c))                    | 20 N.J.R. 2356(a)                 | R.1989 d.380    | 21 N.J.R. 2108(b)                 |
| 8:71              | Interchangeable drug products (see 21 N.J.R. 755(b), 1429(b))                           | 20 N.J.R. 3078(a)                 | R.1989 d.379    | 21 N.J.R. 2108(a)                 |
| 8:71              | Interchangeable drug products   | 21 N.J.R. 662(a)                  | R.1989 d.378    | 21 N.J.R. 2107(c)                 |
| 8:71              | Interchangeable drug products   | 21 N.J.R. 1488(a)                 |                 |                                   |
| 8:71              | Interchangeable drug products   | 21 N.J.R. 1790(a)                 |                 |                                   |

**Most recent update to Title 8: TRANSMITTAL 1989-6 (supplement June 19, 1989)**

**HIGHER EDUCATION—TITLE 9**

|                                   |  |                   |              |                   |
|-----------------------------------|--|-------------------|--------------|-------------------|
| 9:1-5.1, 5.2, 5.4, 5.5, 5.8, 5.10 | Proprietary institutions and academic degree standards             | 21 N.J.R. 1632(a) | R.1989 d.443 | 21 N.J.R. 2498(a) |
| 9:2-4.1                           | Alternate benefit program: eligibility for enrollment              | 21 N.J.R. 1268(a) | R.1989 d.442 | 21 N.J.R. 2499(a) |
| 9:4-1.3, 1.9, 1.10, 2.1-2.15, 7.5 | County community colleges: governance and administration           | 21 N.J.R. 1269(a) |              |                   |
| 9:9-11                            | Stafford Loan Program: institution compliance standards            | 21 N.J.R. 963(a)  | R.1989 d.343 | 21 N.J.R. 1827(b) |
| 9:9-11.1                          | Guaranteed Student Loan Program: institution compliance            | 21 N.J.R. 1962(a) |              |                   |
| 9:11-1.5                          | Educational Opportunity Fund: eligibility for undergraduate grants | 21 N.J.R. 1489(a) | R.1989 d.468 | 21 N.J.R. 2788(a) |
| 9:11-1.8                          | Educational Opportunity Fund: duration of student eligibility      | 21 N.J.R. 1963(a) |              |                   |
| 9:15                              | Graduate medical education program                                 | 21 N.J.R. 1271(a) | R.1989 d.441 | 21 N.J.R. 2500(a) |

**Most recent update to Title 9: TRANSMITTAL 1989-2 (supplement April 17, 1989)**

**HUMAN SERVICES—TITLE 10**

|   |  |                   |              |                   |
|---|--|-------------------|--------------|-------------------|
| 10:38   | Interim Assistance Program for discharged psychiatric hospital clients           | 21 N.J.R. 2280(a) |              |                   |
| 10:39   | Community residences for mentally ill: licensure standards                       | 21 N.J.R. 1995(b) |              |                   |
| 10:43   | Guardians for developmentally disabled persons: determination of need            | 20 N.J.R. 2850(a) | R.1989 d.430 | 21 N.J.R. 2501(a) |
| 10:45   | Guardianship services for developmentally disabled persons                       | 21 N.J.R. 607(a)  |              |                   |
| 10:48-2   | Control of viral hepatitis B among developmentally disabled                      | 20 N.J.R. 2437(a) | R.1989 d.410 | 21 N.J.R. 2507(a) |
| 10:48-3   | Lead toxicity control among developmentally disabled                             | 20 N.J.R. 2555(a) | R.1989 d.347 | 21 N.J.R. 1905(a) |
| 10:48-3   | Lead Toxicity Control Program: comment period                                    | 20 N.J.R. 2688(a) |              |                   |
| 10:49-1.1   | Medicaid program: newborn care   | 21 N.J.R. 965(a)  | R.1989 d.397 | 21 N.J.R. 2383(a) |
| 10:49-1.1   | Medicaid eligibility: administrative correction                                  |                   |              | 21 N.J.R. 2789(a) |
| 10:49-1.1, 1.2  | New Jersey Care: presumptive eligibility for prenatal medical care               | 21 N.J.R. 1791(a) |              |                   |
| 10:49-1.1, 1.7-1.10, 1.14, 1.17, 1.19, 1.20, 1.22, 1.24, 1.26 | Medicaid Administration Manual   | 21 N.J.R. 417(b)  |              |                   |
| 10:52-1.2   | Bed reserve in long-term care facilities   | 21 N.J.R. 1634(a) |              |                   |
| 10:53-1.2   | Bed reserve in long-term care facilities   | 21 N.J.R. 1634(a) |              |                   |
| 10:63-1.13, 1.16  | Bed reserve in long-term care facilities   | 21 N.J.R. 1634(a) |              |                   |
| 10:63-3.9-3.12  | Reimbursement of long-term care facilities: fixed property and movable equipment | 20 N.J.R. 2560(a) |              |                   |
| 10:63-3.10  | Reimbursement of long-term care facilities under CARE Guidelines: correction     | 20 N.J.R. 2968(a) |              |                   |
| 10:63-3.21  | Long-term care facilities: Medicaid occupancy level supplemental payment         | 21 N.J.R. 1456(a) | R.1989 d.368 | 21 N.J.R. 2038(a) |
| 10:65   | Medical Day Care Program   | 21 N.J.R. 1794(a) |              |                   |
| 10:66-1.5   | Independent clinic providers: prior authorization for mental health services     | 21 N.J.R. 1794(b) |              |                   |
| 10:70-3.4   | Medicaid program: newborn care   | 21 N.J.R. 965(a)  |              |                   |
| 10:72-3.4   | Medicaid program: newborn care   | 21 N.J.R. 965(a)  |              |                   |
| 10:72-6.1, 6.3  | New Jersey Care: presumptive eligibility for prenatal medical care               | 21 N.J.R. 1791(a) |              |                   |
| 10:81   | Public Assistance Manual   | 21 N.J.R. 1795(a) |              |                   |
| 10:81-8.22, 8.23  | Public Assistance Manual: Medicaid coverage of newborn children                  | 21 N.J.R. 967(a)  | R.1989 d.448 | 21 N.J.R. 2513(a) |
| 10:81-11.4  | Direct child support payments to AFDC clients                                    | 21 N.J.R. 423(a)  | R.1989 d.337 | 21 N.J.R. 1908(a) |
| 10:81-11.6  | Child Support Program: incentive payment methodology                             | 21 N.J.R. 663(a)  | R.1989 d.465 | 21 N.J.R. 2789(b) |
| 10:81-14.5, 14.18   | REACH Program: post-AFDC child care  | 21 N.J.R. 1086(b) | R.1989 d.353 | 21 N.J.R. 1908(b) |
| 10:82   | Assistance Standards Handbook; AFDC Program                                      | 21 N.J.R. 1811(a) |              |                   |
| 10:85-3.2   | General Assistance: residency and municipal responsibility                       | 21 N.J.R. 835(a)  | R.1989 d.398 | 21 N.J.R. 2384(a) |

| N.J.A.C. CITATION                                      |  | PROPOSAL NOTICE (N.J.R. CITATION) | DOCUMENT NUMBER | ADOPTION NOTICE (N.J.R. CITATION) |
|--|--|-----------------------------------|-----------------|-----------------------------------|
| 10:85-3.3  | General Assistance: income and eligibility                                 | 21 N.J.R. 836(b)                  |                 |                                   |
| 10:87-2.13, 2.30, 2.33, 2.36, 2.37, 4.8, 5.9, 6.2, 9.7 | Food Stamp Program revisions   | 21 N.J.R. 1636(a)                 | R.1989 d.464    | 21 N.J.R. 2790(a)                 |
| 10:120   | Youth and Family Services hearings   | 20 N.J.R. 2742(a)                 | R.1989 d.300    | 21 N.J.R. 2513(b)                 |
| 10:120   | Youth and Family Services hearings: reopening of comment period            | 21 N.J.R. 1580(a)                 |                 |                                   |
| 10:122-3.3, 4.7  | Child care centers: administrative correction                              |                                   |                 | 21 N.J.R. 2385(a)                 |
| 10:123-1   | Financial eligibility for Social Services Program                          | 21 N.J.R. 2438(a)                 |                 |                                   |
| 10:125   | Youth and Family Services capital funding program                          | 21 N.J.R. 1514(a)                 |                 |                                   |
| 10:133   | Personal Attendant Services Program  | 21 N.J.R. 273(b)                  |                 |                                   |
| 10:141-1.4   | Charity Racing Days for Developmentally Disabled: distribution of proceeds | 21 N.J.R. 610(a)                  |                 |                                   |

**Most recent update to Title 10: TRANSMITTAL 1989-6 (supplement June 19, 1989)**

**CORRECTIONS—TITLE 10A**

|                              |   |                   |              |                   |
|------------------------------|---|-------------------|--------------|-------------------|
| 10A:16-2.9                   | Infirmity care  | 21 N.J.R. 969(a)  |              |                   |
| 10A:16-11                    | Special Medical Units   | 21 N.J.R. 111(a)  |              |                   |
| 10A:17-8                     | Recreation and leisure time activities                                      | 21 N.J.R. 665(a)  | R.1989 d.470 | 21 N.J.R. 2793(a) |
| 10A:18-2.6, 2.19, 2.20, 2.22 | Inmate correspondence   | 20 N.J.R. 2854(a) | R.1989 d.338 | 21 N.J.R. 1910(a) |
| 10A:19                       | Public information  | 21 N.J.R. 1490(a) | R.1989 d.440 | 21 N.J.R. 2517(a) |
| 10A:34-2.16, 2.20            | Municipal detention facilities: surveillance of detainees; reporting deaths | 21 N.J.R. 969(b)  | R.1989 d.401 | 21 N.J.R. 2385(a) |

**Most recent update to Title 10A: TRANSMITTAL 1989-5 (supplement June 19, 1989)**

**INSURANCE—TITLE 11**

|   |  |                   |              |                   |
|---|--|-------------------|--------------|-------------------|
| 11:1-3, 7, 8, 13                                | Repeal (see 11:17A, 17B, 17C, 17D)   | 21 N.J.R. 1317(a) |              |                   |
| 11:1-5.1  | FAIR Plan surcharge  | 21 N.J.R. 1816(a) | R.1989 d.478 | 21 N.J.R. 2796(a) |
| 11:1-26   | Insurer profitability information: annual publication  | 21 N.J.R. 2181(a) |              |                   |
| 11:1-27   | Insurer record retention and production for examination  | 21 N.J.R. 2210(a) |              |                   |
| 11:2-3  | Credit life and credit accident and health insurance: preproposal  | 20 N.J.R. 2969(b) |              |                   |
| 11:2-11.1, 11.6, 11.15, 11.18, 23.3, 23.5, 23.8 | Life and health insurance advertising: third-party endorsements  | 21 N.J.R. 970(a)  | R.1989 d.391 | 21 N.J.R. 2039(a) |
| 11:2-11.1, 11.6, 11.18, 23.3, 23.5, 23.8        | Life and health insurance advertising: administrative corrections  |                   |              | 21 N.J.R. 2289(c) |
| 11:2-23.8                                       | Life and health insurance advertising: administrative correction   |                   |              | 21 N.J.R. 2290(a) |
| 11:2-24   | High-risk investments by insurers  | 21 N.J.R. 838(a)  |              |                   |
| 11:3-8.2, 8.4                                   | Nonrenewal of automobile policies  | 21 N.J.R. 1306(a) |              |                   |
| 11:3-16   | Private passenger automobile rate filings  | 21 N.J.R. 2182(a) |              |                   |
| 11:3-18   | Review of rate filings for private passenger automobile coverage   | 21 N.J.R. 839(a)  |              |                   |
| 11:3-25.4                                       | Residual market equalization charges: suspension of certain changes to N.J.A.C. 11:3-25.4; new public comment period | 21 N.J.R. 2208(a) |              |                   |
| 11:3-29   | Automobile insurance personal injury protection: medical fee schedules   | 21 N.J.R. 842(b)  |              |                   |
| 11:4-9  | Life and health insurance: unfiled policy forms  | 21 N.J.R. 1492(a) |              |                   |
| 11:4-11.6                                       | Insurer record retention and production for examination  | 21 N.J.R. 2210(a) |              |                   |
| 11:4-32   | Health service corporations: notice of increased rates   | 21 N.J.R. 973(b)  |              |                   |
| 11:4-33   | Life insurers: excess interest reserve adjustment  | 21 N.J.R. 1308(a) |              |                   |
| 11:4-34   | Long-term care insurance   | 21 N.J.R. 1964(a) |              |                   |
| 11:5-1.10                                       | Real estate broker and salesperson employment agreement  | 21 N.J.R. 1308(b) | R.1989 d.424 | 21 N.J.R. 2519(a) |
| 11:5-1.10                                       | Real estate broker and salesperson employment agreement: correction to proposal summary                              | 21 N.J.R. 1494(a) |              |                   |
| 11:5-1.12                                       | Record maintenance by real estate brokers  | 21 N.J.R. 1310(a) | R.1989 d.425 | 21 N.J.R. 2520(a) |
| 11:5-1.14                                       | License lending by real estate licensees   | 21 N.J.R. 1311(a) | R.1989 d.426 | 21 N.J.R. 2522(a) |
| 11:5-1.15                                       | Advertising by licensed real estate brokers  | 21 N.J.R. 1312(a) | R.1989 d.447 | 21 N.J.R. 2522(b) |
| 11:5-1.16                                       | Real estate listing agreements   | 20 N.J.R. 2185(a) |              |                   |
| 11:5-1.16                                       | Real estate contracts: "agreement to honor" provision  | 21 N.J.R. 2438(b) |              |                   |
| 11:5-1.18                                       | Supervision of primary real estate offices   | 21 N.J.R. 1312(b) | R.1989 d.427 | 21 N.J.R. 2523(a) |
| 11:5-1.19                                       | Supervision of branch real estate offices  | 21 N.J.R. 1313(a) | R.1989 d.428 | 21 N.J.R. 2523(b) |
| 11:5-1.23                                       | Real estate offers and broker's obligations  | 20 N.J.R. 2186(a) |              |                   |
| 11:5-1.28                                       | Approval real estate schools: pre-proposal   | 21 N.J.R. 1641(a) |              |                   |
| 11:5-3, 4, 5                                    | Formal proceedings by Real Estate Commission   | 21 N.J.R. 1314(a) | R.1989 d.429 | 21 N.J.R. 2524(a) |
| 11:13-1.2, 1.3                                  | Farm-owners insurance  | 21 N.J.R. 1641(b) |              |                   |
| 11:15   | Hospital workers' compensation: group self-insurance   | 21 N.J.R. 1817(a) |              |                   |
| 11:15-2.2, 2.13, 2.21                           | Joint insurance funds for local government units   | 21 N.J.R. 1494(b) |              |                   |

| N.J.A.C. CITATION     |   | PROPOSAL NOTICE (N.J.R. CITATION) | DOCUMENT NUMBER | ADOPTION NOTICE (N.J.R. CITATION) |
|-----------------------|---|-----------------------------------|-----------------|-----------------------------------|
| 11:17A, 17B, 17C, 17D | Insurance producer conduct: marketing; commissions and fees; funds management; administrative penalties | 21 N.J.R. 1317(a)                 |                 |                                   |
| 11:18                 | Medical Malpractice Reinsurance Recovery Fund surcharge   | 21 N.J.R. 1642(a)                 |                 |                                   |
| 11:18                 | Medical Malpractice Reinsurance Recovery Fund surcharge: public hearing                                 | 21 N.J.R. 2213(a)                 |                 |                                   |

**Most recent update to Title 11: TRANSMITTAL 1989-6 (supplement June 19, 1989)**

#### LABOR—TITLE 12

|                         |  |                   |              |                   |
|-------------------------|--|-------------------|--------------|-------------------|
| 12:20                   | Board of Review: appeals of unemployment benefit determinations                      | 21 N.J.R. 1496(a) | R.1989 d.473 | 21 N.J.R. 2797(a) |
| 12:20-6                 | Unemployment and disability insurance appeals: telephone hearings                    | 21 N.J.R. 1644(a) | R.1989 d.474 | 21 N.J.R. 2798(a) |
| 12:41-1                 | Job Training Partnership Act/N.J. Jobs Training Act: grievance procedures            | 21 N.J.R. 1498(a) | R.1989 d.475 | 21 N.J.R. 2799(a) |
| 12:45-1                 | Vocational rehabilitation services   | 20 N.J.R. 3107(a) |              |                   |
| 12:45-3                 | Vocational rehabilitation services: vehicle modification requirements                | 21 N.J.R. 2213(b) |              |                   |
| 12:46-12:49             | Repeal (see 12:45-1)   | 20 N.J.R. 3107(a) |              |                   |
| 12:100                  | Safety and health standards for public employees                                     | 21 N.J.R. 2224(a) |              |                   |
| 12:100-4.2              | Public employee safety and health: air contaminant exposure limits                   | 21 N.J.R. 1089(a) | R.1989 d.358 | 21 N.J.R. 1829(a) |
| 12:100-4.2, 5.2         | Public employee safety and health: hazardous waste operations and emergency response | 21 N.J.R. 1646(a) | R.1989 d.476 | 21 N.J.R. 2800(a) |
| 12:100-4.2, 5.2, 6.2, 7 | Public employee safety and health: toxic and hazardous substances                    | 20 N.J.R. 2013(a) | Expired      |                   |
| 12:100-4.2, 10, 17      | Safety standards for firefighters  | 21 N.J.R. 1090(a) |              |                   |
| 12:100-4.2, 10, 17      | Safety standards for firefighters: public hearing                                    | 21 N.J.R. 1500(a) |              |                   |
| 12:100-8                | Public employee safety and health: indoor firing ranges                              | 21 N.J.R. 1094(a) | R.1989 d.357 | 21 N.J.R. 1829(b) |
| 12:100-9.2              | Public employee safety and health: work in confined spaces                           | 21 N.J.R. 1647(a) | R.1989 d.477 | 21 N.J.R. 2800(b) |
| 12:102-1                | Field sanitation for seasonal farm workers   | 21 N.J.R. 2224(b) |              |                   |

**Most recent update to Title 12: TRANSMITTAL 1989-5 (supplement June 19, 1989)**

#### COMMERCE, ENERGY, AND ECONOMIC DEVELOPMENT—TITLE 12A

|                            |  |                              |              |                   |
|----------------------------|--|------------------------------|--------------|-------------------|
| 12A:10-1, 2 (17:13, 17:14) | Small businesses, urban development enterprises; minority and female subcontractor participation | Emergency (expires 10-13-89) | R.1989 d.481 | 21 N.J.R. 2810(a) |
| 12A:55                     | Solar energy systems: criteria for sales and use tax exemption                                   | 21 N.J.R. 282(a)             |              |                   |
| 12A:55                     | Solar energy systems criteria for sales and use tax exemptions: extension of comment period      | 21 N.J.R. 1969(a)            |              |                   |
| 12A:61                     | Energy emergencies (formerly at 14A:2)   | 21 N.J.R. 1272(a)            |              |                   |
| 12A:120-2                  | Urban Enterprise Zone Program: certification for zone business benefits                          | 21 N.J.R. 693(a)             | R.1989 d.376 | 21 N.J.R. 2043(a) |

**Most recent update to Title 12A: TRANSMITTAL 1989-4 (supplement May 15, 1989)**

#### LAW AND PUBLIC SAFETY—TITLE 13

|  |   |                   |              |                   |
|--|---|-------------------|--------------|-------------------|
| 13:1-4.5   | Police Training Commission: instructor certification                | 21 N.J.R. 1647(b) |              |                   |
| 13:2-20  | Transportation of alcoholic beverages by licensees; insignia        | 21 N.J.R. 1300(a) | R.1989 d.372 | 21 N.J.R. 2045(a) |
| 13:2-20.2  | Transportation by retail licensee: administrative correction        | _____             | _____        | 21 N.J.R. 2385(c) |
| 13:2-21  | Transportation of alcoholic beverages into, through or out of State | 21 N.J.R. 1304(a) | R.1989 d.371 | 21 N.J.R. 2047(a) |
| 13:18-11   | Organization of the Division of Motor Vehicles                      | Exempt            | R.1989 d.365 | 21 N.J.R. 2048(a) |
| 13:19  | Driver control service  | 21 N.J.R. 1817(b) |              |                   |
| 13:19-13   | Supplemental motor vehicle insurance surcharges                     | 21 N.J.R. 1817(b) |              |                   |
| 13:20-1  | Division of Motor Vehicles: enforcement officer rules               | 21 N.J.R. 1500(b) |              |                   |
| 13:20-3  | Repeal (see 13:24)  | 21 N.J.R. 2460(a) |              |                   |
| 13:24  | Emergency vehicle equipment   | 21 N.J.R. 2460(a) |              |                   |
| 13:30-1.2, 2.18, 8.1                               | Board of Dentistry licensure and registration fees                  | 21 N.J.R. 2466(a) |              |                   |
| 13:30-1.5, 1.15, 1.16, 2.11, 2.12, 2.13, 6.9, 6.10 | Board of Dentistry: administrative corrections                      | _____             | _____        | 21 N.J.R. 2386(a) |
| 13:30-2.19   | Inactive dental hygienists: resumption of practice                  | 21 N.J.R. 1500(c) | R.1989 d.460 | 21 N.J.R. 2801(a) |
| 13:30-8.12   | Board of Dentistry: accuracy of dental insurance forms              | 21 N.J.R. 2226(a) |              |                   |
| 13:35  | Board of Medical Examiners rules                                    | 21 N.J.R. 2226(b) |              |                   |
| 13:35-6.2  | Pronouncement and certification of death                            | 21 N.J.R. 1969(b) |              |                   |
| 13:35-8.18   | Hearing aid dispensers: continuing education                        | 21 N.J.R. 1648(a) |              |                   |
| 13:36  | State Board of mortuary science                                     | 21 N.J.R. 1971(a) |              |                   |
| 13:36-2.1, 2.5, 4.8, 5.12, 5.13                    | Mortuary science: administrative corrections                        | _____             | _____        | 21 N.J.R. 1830(a) |
| 13:36-3.5, 3.6, 3.7                                | Mortuary science: examination requirements and review procedure     | 21 N.J.R. 1820(a) |              |                   |
| 13:37-2.3, 3.5, 4.4                                | Nursing practice: temporary permit holders                          | 21 N.J.R. 1648(b) |              |                   |

| <b>N.J.A.C. CITATION</b> |  | <b>PROPOSAL NOTICE (N.J.R. CITATION)</b> | <b>DOCUMENT NUMBER</b> | <b>ADOPTION NOTICE (N.J.R. CITATION)</b> |
|--------------------------|--|--|------------------------|--|
| 13:38-1.2                | Practice of optometry: unlawful advertising                                    | 21 N.J.R. 2467(a)                        |                        |  |
| 13:39A-3.2               | Unlawful practices and arrangements by physical therapists: preproposal        | 20 N.J.R. 2242(a)                        |                        |  |
| 13:39A-5.1               | Educational requirements for licensure as physical therapist                   | 20 N.J.R. 2243(a)                        |                        |  |
| 13:42-1.2                | Board of Psychological Examiners: written examination fee                      | 21 N.J.R. 1649(a)                        | R.1989 d.467           | 21 N.J.R. 2801(b)                        |
| 13:44                    | Board of Veterinary Medical Examiners  | 21 N.J.R. 1501(a)                        | R.1989 d.459           | 21 N.J.R. 2801(c)                        |
| 13:44D                   | Public movers and warehousemen   | 20 N.J.R. 2364(a)                        | R.1989 d.400           | 21 N.J.R. 2386(b)                        |
| 13:44D                   | Public movers and warehousemen: public hearing and extension of comment period | 20 N.J.R. 2681(a)                        |                        |  |
| 13:45A-11.1              | Advertising and sale of new merchandise  | 20 N.J.R. 2247(a)                        |                        |  |
| 13:45A-26.6              | Automotive dispute resolution: administrative correction                       | _____                                    | _____                  | 21 N.J.R. 1831(a)                        |
| 13:45B-4                 | Temporary help service firms   | 20 N.J.R. 2684(a)                        |                        |  |
| 13:47-2.8                | Legalized games of chance: organization ID numbers                             | 21 N.J.R. 698(a)                         | R.1989 d.399           | 21 N.J.R. 2396(b)                        |
| 13:47-7.1                | Bingo games  | 21 N.J.R. 698(b)                         | R.1989 d.431           | 21 N.J.R. 2526(a)                        |
| 13:47-14.3               | Rental or use of premises for bingo games                                      | 21 N.J.R. 2233(a)                        |                        |  |
| 13:47C                   | Weights and measures: general commodities                                      | 21 N.J.R. 1096(a)                        | R.1989 d.350           | 21 N.J.R. 1832(a)                        |
| 13:70-3.40               | Horse racing: admittance of children to race track                             | 21 N.J.R. 1972(a)                        |                        |  |
| 13:71-5.18               | Harness racing: admittance of children to race track                           | 21 N.J.R. 1972(b)                        |                        |  |
| 13:75                    | Practice and procedure before Violent Crimes Compensation Board                | 21 N.J.R. 881(b)                         | R.1989 d.340           | 21 N.J.R. 1832(b)                        |

**Most recent update to Title 13: TRANSMITTAL 1989-6 (supplement June 19, 1989)**

#### **PUBLIC UTILITIES—TITLE 14**

|                |  |                   |              |                   |
|----------------|--|-------------------|--------------|-------------------|
| 14:0           | Telecommunications for deaf: pre-proposal concerning Statewide 24-hour dual party relay center | 21 N.J.R. 1653(a) |              |                   |
| 14:3-3.2       | Customer's proof of identity   | 21 N.J.R. 2004(a) |              |                   |
| 14:3-3.6       | Utility service discontinuance   | 21 N.J.R. 1650(a) |              |                   |
| 14:3-4.5, 4.10 | Billing disputes and meter test options  | 21 N.J.R. 1650(b) |              |                   |
| 14:3-4.7       | Water meter accuracy and billing adjustments   | 21 N.J.R. 1651(a) |              |                   |
| 14:3-7.5       | Return of customer deposits  | 21 N.J.R. 1652(a) |              |                   |
| 14:3-7.13      | Late payment charges   | 21 N.J.R. 1652(b) |              |                   |
| 14:3-10.15     | Annual filing of customer lists by solid waste collectors; annual reports                      | 20 N.J.R. 2629(a) |              |                   |
| 14:3-11        | Earned return analysis of utility rates  | 21 N.J.R. 2003(a) |              |                   |
| 14:9-3.3       | Water meter accuracy and billing adjustments   | 21 N.J.R. 1651(a) |              |                   |
| 14:10-6        | Telecommunications: Alternative Operator Service (AOS) providers                               | 20 N.J.R. 3115(a) | R.1989 d.463 | 21 N.J.R. 2801(d) |

**Most recent update to Title 14: TRANSMITTAL 1989-2 (supplement May 15, 1989)**

#### **ENERGY—TITLE 14A**

|            |   |                   |              |                   |
|------------|---|-------------------|--------------|-------------------|
| 14A:2      | Energy emergencies (expired rules to be adopted as new at 12A:61) | 21 N.J.R. 1272(a) |              |                   |
| 14A:6-2    | Business Energy Improvement Program                               | 21 N.J.R. 2005(a) |              |                   |
| 14A:8      | Energy Facility Review Board                                      | 21 N.J.R. 2009(a) |              |                   |
| 14A:11     | Reporting by energy industries of energy information              | 21 N.J.R. 2009(b) |              |                   |
| 14A:14-2.1 | Definition of electric facility                                   | 21 N.J.R. 882(a)  | R.1989 d.364 | 21 N.J.R. 2048(a) |
| 14A:22     | Commercial and Apartment Conservation Service Program             | 21 N.J.R. 2010(a) |              |                   |

**Most recent update to Title 14A: TRANSMITTAL 1989-1 (supplement February 21, 1989)**

#### **STATE—TITLE 15**

**Most recent update to Title 15: TRANSMITTAL 1989-1 (supplement February 21, 1989)**

#### **PUBLIC ADVOCATE—TITLE 15A**

**Most recent update to Title 15A: TRANSMITTAL 1987-1 (supplement April 20, 1987)**

#### **TRANSPORTATION—TITLE 16**

|                             |  |                   |              |                   |
|-----------------------------|--|-------------------|--------------|-------------------|
| 16:1A                       | Organization of the Department of Transportation   | Exempt            | R.1989 d.366 | 21 N.J.R. 2049(a) |
| 16:1A-1.3                   | Filing of rulemaking petitions   | 21 N.J.R. 2233(b) |              |                   |
| 16:6                        | Right-of-way acquisitions and relocation assistance  | 21 N.J.R. 1273(a) | R.1989 d.421 | 21 N.J.R. 2290(b) |
| 16:14, 15, 18               | State aid road system; county operations; construction equipment damage program  | 21 N.J.R. 1282(a) | R.1989 d.367 | 21 N.J.R. 2050(a) |
| 16:14, 15, 18               | State aid road system; county operations; construction equipment damage program: correction to proposal summary                    | 21 N.J.R. 2234(a) |              |                   |
| 16:25-1.1, 1.7, 2.2, 7A, 13 | Installation of fiber optic cable along limited access highways  | 21 N.J.R. 2234(b) |              |                   |
| 16:26-1, 2, 3               | Bureau of Electrical Engineering: release of traffic signal information; drawbridge operations; reimbursed highway safety lighting | 21 N.J.R. 1653(b) | R.1989 d.458 | 21 N.J.R. 2804(a) |
| 16:28-1.49                  | Speed limits along Route 35 in Woodbridge  | 21 N.J.R. 1097(a) | R.1989 d.344 | 21 N.J.R. 1832(c) |

| N.J.A.C. CITATION  |   | PROPOSAL NOTICE (N.J.R. CITATION) | DOCUMENT NUMBER | ADOPTION NOTICE (N.J.R. CITATION) |
|--|---|-----------------------------------|-----------------|-----------------------------------|
| 16:28-1.72, 1.77   | School and speed limit zones along U.S. 206 in Hamilton and Route 29 in Stockton  | 21 N.J.R. 1501(b)                 | R.1989 d.411    | 21 N.J.R. 2299(a)                 |
| 16:28A-1.1, 1.21, 1.24, 1.38   | Parking and stopping restrictions along U.S. 1 in Plainsboro, U.S. 30 in Somerdale, Route 34 in Old Bridge, and Route 71 in Asbury Park | 21 N.J.R. 1283(a)                 | R.1989 d.374    | 21 N.J.R. 2050(b)                 |
| 16:28A-1.7   | Bus stop zone along U.S. 9 in Old Bridge  | 21 N.J.R. 1284(a)                 | R.1989 d.375    | 21 N.J.R. 2051(a)                 |
| 16:28A-1.21  | Bus stop zones along U.S. 30 in Lindenwold  | 21 N.J.R. 1097(b)                 | R.1989 d.345    | 21 N.J.R. 1832(d)                 |
| 16:33  | Repeal (see 16:45)  | 21 N.J.R. 1972(c)                 |                 |                                   |
| 16:41A-1.1, 2.2, 2.4, 2.5, 2.9, 2.10, 2.11, 3.1, 3.2, 3.3, 3.15, 3.19, 3.20, 4.2, 4.4, 5.2, 5.4, 6.1, 6.4, 7.1 | Outdoor Advertising Tax Act rules   | 21 N.J.R. 2237(a)                 |                 |                                   |
| 16:44-1.1  | Contract administration: prequalification committee   | 21 N.J.R. 2240(a)                 |                 |                                   |
| 16:44-1.2, 1.4   | Classification of prospective bidders   | 21 N.J.R. 1023(a)                 | R.1989 d.346    | 21 N.J.R. 1833(a)                 |
| 16:44-5.5  | Contract administration: verification of bid calculations   | 21 N.J.R. 2239(a)                 |                 |                                   |
| 16:45  | Construction control: contractor claims; substantial completion   | 21 N.J.R. 1972(c)                 |                 |                                   |
| 16:46-1, 2   | Drawbridge operations; reimbursed highway safety lighting   | 21 N.J.R. 2468(a)                 |                 |                                   |
| 16:53  | Autobus specifications and inspection fees  | 21 N.J.R. 1098(a)                 | R.1989 d.392    | 21 N.J.R. 2051(b)                 |
| 16:53B   | Jurisdictional assignments for railroad overhead bridges  | 21 N.J.R. 1103(a)                 | R.1989 d.356    | 21 N.J.R. 1833(b)                 |
| 16:56  | Airport Safety Improvement Aid  | 21 N.J.R. 1502(a)                 | R.1989 d.413    | 21 N.J.R. 2299(b)                 |
| 16:82  | NJ TRANSIT: availability of public records  | 21 N.J.R. 284(b)                  | R.1989 d.462    | 21 N.J.R. 2804(b)                 |

**Most recent update to Title 16: TRANSMITTAL 1989-6 (supplement June 19, 1989)**

**TREASURY-GENERAL—TITLE 17**

|                  |   |                              |              |                   |
|------------------|---|------------------------------|--------------|-------------------|
| 17:2             | Public Employees' Retirement System   | 21 N.J.R. 2429(a)            |              |                   |
| 17:2-4.3         | Public Employees' Retirement System: school year members  | 21 N.J.R. 979(a)             | R.1989 d.423 | 21 N.J.R. 2300(a) |
| 17:2-5.13        | Public Employees' Retirement System: lump-sum service purchases                                       | 21 N.J.R. 1820(b)            |              |                   |
| 17:2-6.27        | Public Employees' Retirement System: benefit coverage during work-related travel                      | 21 N.J.R. 1285(a)            | R.1989 d.422 | 21 N.J.R. 2300(b) |
| 17:3-4.3         | Teachers' Pension and Annuity Fund: school year members   | 21 N.J.R. 980(a)             | R.1989 d.359 | 21 N.J.R. 2055(a) |
| 17:3-5.9         | Teachers' Pension and Annuity Fund: lump-sum purchases  | 21 N.J.R. 980(b)             | R.1989 d.360 | 21 N.J.R. 2055(b) |
| 17:4-5.7         | Police and Firemen's Retirement System: lump-sum service purchases                                    | 21 N.J.R. 1821(a)            |              |                   |
| 17:9-2.4, 5.11   | State Health Benefits Program: enrollment of dependents of 10-month employees                         | 21 N.J.R. 886(a)             | R.1989 d.335 | 21 N.J.R. 1836(a) |
| 17:9-2.6, 2.7    | State Health Benefits Program: effective date of coverage   | 21 N.J.R. 1503(a)            | R.1989 d.469 | 21 N.J.R. 2807(a) |
| 17:9-2.18, 3.1   | State Health Benefits Program: continuation of coverage for disabled children                         | 21 N.J.R. 885(a)             |              |                   |
| 17:9-7.2         | State Health Benefits Program: reenrollment after termination of covered public employment            | 21 N.J.R. 886(b)             | R.1989 d.336 | 21 N.J.R. 1836(b) |
| 17:12            | Purchase Bureau rules   | Emergency (expires 10-13-89) | R.1989 d.481 | 21 N.J.R. 2810(a) |
| 17:13 (12A:10-1) | Goods and services contracts for small businesses, urban development enterprises and micro businesses | Emergency (expires 10-13-89) | R.1989 d.481 | 21 N.J.R. 2810(a) |
| 17:14 (12A:10-2) | Minority and female subcontractor participation in State construction contracts                       | Emergency (expires 10-13-89) | R.1989 d.481 | 21 N.J.R. 2810(a) |
| 17:16-17.3       | Common Pension Fund A: investment limitations   | 21 N.J.R. 1821(b)            | R.1989 d.466 | 21 N.J.R. 2808(a) |
| 17:20-8.1        | Lottery vendors' code of ethics   | 21 N.J.R. 631(a)             | R.1989 d.381 | 21 N.J.R. 2055(c) |

**Most recent update to Title 17: TRANSMITTAL 1989-5 (supplement June 19, 1989)**

**TREASURY-TAXATION—TITLE 18**

|                       |   |                   |              |                   |
|-----------------------|---|-------------------|--------------|-------------------|
| 18:1-1.1, 1.2         | Organization of Division of Taxation  | Exempt            | R.1989 d.437 | 21 N.J.R. 2526(b) |
| 18:7-8.10             | Corporation Business Tax: sales of certain services to a regulated investment company | 21 N.J.R. 1106(a) | R.1989 d.439 | 21 N.J.R. 2527(a) |
| 18:7-11.8, 13.3, 13.8 | Corporation Business Tax: refund procedures   | 21 N.J.R. 1503(b) |              |                   |
| 18:7-14.20            | Tax Clearance Certificate   | Exempt            | R.1989 d.437 | 21 N.J.R. 2526(b) |
| 18:24-1.4, 12.5       | Sales and Use Tax: receipts   | 21 N.J.R. 1107(a) |              |                   |
| 18:24-5.11            | Fabricator/contractor sales and use tax liability                                     | 21 N.J.R. 439(a)  | R.1989 d.438 | 21 N.J.R. 2528(a) |
| 18:26-2.12            | Transfer Inheritance and Estate Tax: renunciation or disclaimer                       | 21 N.J.R. 1822(a) |              |                   |

**Most recent update to Title 18: TRANSMITTAL 1989-4 (supplement June 19, 1989)**

**TITLE 19—OTHER AGENCIES**

|           |   |                   |  |  |
|-----------|---|-------------------|--|--|
| 19:8-1.12 | Garden State Parkway: transportation of hazardous materials | 21 N.J.R. 1974(a) |  |  |
|-----------|---|-------------------|--|--|

| N.J.A.C. CITATION  |   | PROPOSAL NOTICE (N.J.R. CITATION) | DOCUMENT NUMBER | ADOPTION NOTICE (N.J.R. CITATION) |
|--------------------|---|-----------------------------------|-----------------|-----------------------------------|
| 19:8-8.1           | Garden State Parkway: special permits for oversize vehicles               | 21 N.J.R. 1974(b)                 |                 |                                   |
| 19:8-11            | Highway Authority organizational rules                                    | Exempt                            | R.1989 d.361    | 21 N.J.R. 2056(a)                 |
| 19:8-12            | Garden State Parkway: petitions for rules                                 | 21 N.J.R. 1975(a)                 |                 |                                   |
| 19:9-6             | Turnpike Authority: petitions for rules                                   | 21 N.J.R. 2440(a)                 |                 |                                   |
| 19:9-7             | Organization of Turnpike Authority  | Exempt                            | R.1989 d.444    | 21 N.J.R. 2528(b)                 |
| 19:10-6.1          | PERC: rulemaking petitions  | 21 N.J.R. 1505(a)                 | R.1989 d.461    | 21 N.J.R. 2808(b)                 |
| 19:20-2            | Use of authority facilities   | 21 N.J.R. 887(b)                  |                 |                                   |
| 19:25-15           | Public financing of general election for Governor                         | 21 N.J.R. 1109(a)                 | R.1989 d.341    | 21 N.J.R. 1837(a)                 |
| 19:25-15.29        | Coordinated expenditures in general election for Governor                 | Emergency (expires 10-2-89)       | R.1989 d.456    | 21 N.J.R. 2673(a)                 |
| 19:25-15.29, 16.30 | Public financing of gubernatorial elections: coordinated expenditures     | 21 N.J.R. 1286(a)                 | R.1989 d.382    | 21 N.J.R. 2056(b)                 |
| 19:25-15.48        | Candidate statement of qualification: administrative correction           | _____                             | _____           | 21 N.J.R. 2530(a)                 |
| 19:61-3.2          | Executive Commission on Ethical Standards: subpoena for witnesses         | 21 N.J.R. 1507(b)                 |                 |                                   |
| 19:61-3.2, 5.5     | Subpoena for witnesses; rulemaking petitions: extension of comment period | 21 N.J.R. 2441(b)                 |                 |                                   |
| 19:61-5.5          | Rulemaking petitions  | 21 N.J.R. 1508(a)                 |                 |                                   |

**Most recent update to Title 19: TRANSMITTAL 1989-5 (supplement May 15, 1989)**

**TITLE 19 SUBTITLE K—CASINO CONTROL COMMISSION/CASINO REINVESTMENT DEVELOPMENT AUTHORITY**

|                     |  |                   |              |                   |
|---------------------|--|-------------------|--------------|-------------------|
| 19:40               | Commission operations and procedures                                       | 21 N.J.R. 1975(b) |              |                   |
| 19:41-7.2B          | Reporting of proposed foreign gaming operations                            | 21 N.J.R. 129(b)  |              |                   |
| 19:41-8             | Receipt and processing of applications                                     | 21 N.J.R. 1975(b) |              |                   |
| 19:41-8.6           | Withdrawal of application for licensure                                    | 21 N.J.R. 130(a)  |              |                   |
| 19:41-10            | Professional practice (recodify to 19:40-5)                                | 21 N.J.R. 1975(b) |              |                   |
| 19:42-8.1           | Hearings on rules  | 21 N.J.R. 1975(b) |              |                   |
| 19:45-1.3           | Section 99 submissions   | 21 N.J.R. 1506(a) | R.1989 d.457 | 21 N.J.R. 2808(c) |
| 19:45-1.28          | Deposit of checks from gaming patrons                                      | 21 N.J.R. 1288(a) | R.1989 d.434 | 21 N.J.R. 2530(b) |
| 19:47-2.6, 2.9      | Insurance wagers in blackjack  | 21 N.J.R. 2441(a) |              |                   |
| 19:49-3.1, 3.2, 3.3 | Junket reporting requirements  | 20 N.J.R. 2648(b) |              |                   |
| 19:52-1.3           | Musical entertainment  | 20 N.J.R. 2649(a) |              |                   |
| 19:53-1.5           | Employment of minority and female workers                                  | 21 N.J.R. 1823(a) |              |                   |
| 19:53-2.7           | Casino business with minority and women's enterprises: quarterly reporting | 21 N.J.R. 1507(a) | R.1989 d.414 | 21 N.J.R. 2301(a) |

**Most recent update to Title 19K: TRANSMITTAL 1989-6 (supplement June 19, 1989)**

**RULEMAKING IN THIS ISSUE—Continued**

| Filing Deadlines  |              | November 6 issue:  |       |
|-------------------|--------------|--------------------|-------|
| October 2 issue:  |              | Proposals .....    | Octob |
| Adoptions .....   | September 11 | Adoptions .....    | Octob |
| October 16 issue: |              | November 20 issue: |       |
| Proposals .....   | September 15 | Proposals .....    | Octob |
| Adoptions .....   | September 22 | Adoptions .....    | Octob |