

**CHAPTER 20
ENFORCEMENT SERVICE**

Authority

N.J.S.A. 39:2-3, 39:3-10, 39:3-11, 39:3-27.14, 39:3-27.39, 39:3-33.3, 39:3-33.7, 39:3-33.9, 39:3-43, 39:3-75, 39:3-77, 39:3-81, 39:3-84a(10), 39:4-208, 39:5-30, 39:8-1, 39:8-2, 39:8-4, 39:8-4.1, 39:8-23 and 39:10-4.

Source and Effective Date

R.1991 d.20, effective December 13, 1990.
See: 22 N.J.R. 3307(a), 23 N.J.R. 207(b).

Executive Order No. 66(1978) Expiration Date

Chapter 20, Enforcement Service, will expire on December 13, 1995.

Chapter Historical Note

Pursuant to Executive Order No. 66(1978), Chapter 20 was readopted as R.1991 d.20. See: Source and Effective Date.

See Subchapter and section annotations for specific rulemaking activity.

CHAPTER TABLE OF CONTENTS

SUBCHAPTER 1. (RESERVED)

SUBCHAPTER 2. VEHICLE CONSTRUCTION

- 13:20-2.1 Vehicle construction and load
- 13:20-2.2 Direction signals approval

SUBCHAPTER 3. (RESERVED)

SUBCHAPTER 4. POWER STEERING INSTALLATION

- 13:20-4.1 Permitted power steering device
- 13:20-4.2 Equipment approval

SUBCHAPTER 5. MANUAL DOOR EQUIPMENT

- 13:20-5.1 Purpose
- 13:20-5.2 Manual opening of doors
- 13:20-5.3 Exceptions

SUBCHAPTER 6. MUFFLER DEVICES

- 13:20-6.1 Prohibitory muffler devices

SUBCHAPTER 7. VEHICLE INSPECTION

- 13:20-7.1 Adjustments, corrections or repairs
- 13:20-7.2 Immediate repairs
- 13:20-7.3 (Reserved)
- 13:20-7.4 Inspection period of passenger vehicles
- 13:20-7.5 Temporary authorization certificate; form
- 13:20-7.6 Inspection period
- 13:20-7.7 Initial passenger vehicle inspection procedure
- 13:20-7.8 Initial inspection certificate data
- 13:20-7.9 Definitions
- 13:20-7.10 Inspection procedure
- 13:20-7.11 New vehicle purchaser procedure
- 13:20-7.12 Motor vehicle tires
- 13:20-7.13 Expired inspection certificates

SUBCHAPTER 8. MOTOR VEHICLES TRANSPORTING FLAMMABLE LIQUIDS

- 13:20-8.1 Scope and purpose
- 13:20-8.2 Definitions
- 13:20-8.3 General provisions
- 13:20-8.4 Existing tank vehicles continuing in service; specification tanks of tank vehicles
- 13:20-8.5 Existing nonspecification tanks of tank vehicles
- 13:20-8.6 New tank vehicles
- 13:20-8.7 Novel tanks of tank motor vehicles
- 13:20-8.8 Accident to vehicle; warning: no sparks or flame
- 13:20-8.9 Prevent leakage from spreading
- 13:20-8.10 Disposition of contents of cargo tank when unsafe to continue
- 13:20-8.11 Transfer of flammable liquids en route
- 13:20-8.12 Transportation of leaking cargo tanks
- 13:20-8.13 Smoking by tank vehicle drivers
- 13:20-8.14 Basic design
- 13:20-8.15 Cargo tanks, piping and connections designed for flammable liquids having a vapor pressure of 18 psia or over at 100 degrees Fahrenheit
- 13:20-8.16 Cargo tanks, piping and connections designed for flammable liquids having a vapor pressure under 18 psia at 100 degrees Fahrenheit
- 13:20-8.17 Cargo tanks constructed of mild steel
- 13:20-8.18 Bulkhead, baffle and shell sheets
- 13:20-8.19 Cargo tanks constructed of low alloy low carbon (high tensile) steel and stainless steel
- 13:20-8.20 Cargo tanks constructed of aluminum alloys for high strength welded construction
- 13:20-8.21 Joints
- 13:20-8.22 Combination steel sheets
- 13:20-8.23 Welded aluminum joints
- 13:20-8.24 Compartmentalized cargo tanks
- 13:20-8.25 Test leaks
- 13:20-8.26 Tank outlets
- 13:20-8.27 Drawoff valves
- 13:20-8.28 Vents
- 13:20-8.29 Manholes
- 13:20-8.30 Shutoff valves
- 13:20-8.31 Overflow protection
- 13:20-8.32 Marking tank vehicles
- 13:20-8.33 Construction and equipment of tank vehicle chassis assembly and appurtenances
- 13:20-8.34 Fuel system
- 13:20-8.35 Exhaust system
- 13:20-8.36 Full trailers and semi-trailers
- 13:20-8.37 Fire extinguishers
- 13:20-8.38 Auxiliary internal combustion engines
- 13:20-8.39 Auxiliary electric generators and motors
- 13:20-8.40 Operation of tank vehicles
- 13:20-8.41 Protection against intermixing

SUBCHAPTER 9. SPECIAL VEHICLE IDENTIFICATION CARD

- 13:20-9.1 Identification card requirements
- 13:20-9.2 Medical evidence by amputees
- 13:20-9.3 State driver's license or registration qualification
- 13:20-9.4 Limitation on number of certificates
- 13:20-9.5 Passenger vehicles
- 13:20-9.6 Temporary certificates
- 13:20-9.7 Immediate family members

SUBCHAPTER 10. AUTOMATIC VEHICLE IDENTIFICATION SYSTEMS

- 13:20-10.1 Definitions
- 13:20-10.2 Application
- 13:20-10.3 Placement

SUBCHAPTER 11. SCHOOL BUS WARNING LAMPS

- 13:20-11.1 General requirements

- 13:20-11.2 Color specifications
- 13:20-11.3 Aiming pads
- 13:20-11.4 Tests
- 13:20-11.5 Lamp housing
- 13:20-11.6 Wiring
- 13:20-11.7 Flashers; tests
- 13:20-11.8 Approval
- 13:20-11.9 Verification test
- 13:20-11.10 Installation
- 13:20-11.11 Start-up tests; repairs
- 13:20-11.12 Approved lamps, switches and relays
- 13:20-11.13 Compliance

SUBCHAPTER 12. ACCIDENT PREVENTION CLINIC

- 13:20-12.1 Definitions
- 13:20-12.2 Recexamination; categories
- 13:20-12.3 Vision examination

SUBCHAPTER 13. (RESERVED)

SUBCHAPTER 14. PARKING ON STATE PROPERTY

- 13:20-14.1 Vehicle registration and parking permit
- 13:20-14.2 Application
- 13:20-14.3 Affixing permit
- 13:20-14.4 Infringement on reserved spaces
- 13:20-14.5 Duration of parking privilege
- 13:20-14.6 Suspension
- 13:20-14.7 Penalty

SUBCHAPTER 15. STUD TIRES

- 13:20-15.1 Definitions
- 13:20-15.2 Federal requirements
- 13:20-15.3 Application for product approval
- 13:20-15.4 Provisional certificate

SUBCHAPTER 16. CONCRETE READY-MIX TRANSIT VEHICLES

- 13:20-16.1 Lighting exceptions

SUBCHAPTER 17. DRIVER IMPROVEMENT SCHOOLS

- 13:20-17.1 Purpose
- 13:20-17.2 Attendance
- 13:20-17.3 Amount of fee
- 13:20-17.4 Manner of payment
- 13:20-17.5 Penalty

SUBCHAPTER 18. FLASHING WARNING SIGNALS

- 13:20-18.1 Switching approval
- 13:20-18.2 Vehicular hazard warning signal defined
- 13:20-18.3 Electrical components
- 13:20-18.4 Independent or combination unit
- 13:20-18.5 Operation independent of ignition
- 13:20-18.6 Operating motion
- 13:20-18.7 Actuation of switches
- 13:20-18.8 Wiring
- 13:20-18.9 Contact points
- 13:20-18.10 Printed circuit
- 13:20-18.11 Pilot indicators
- 13:20-18.12 Flashers
- 13:20-18.13 Fuse
- 13:20-18.14 Application for product approval
- 13:20-18.15 Temporary certificate
- 13:20-18.16 Approval
- 13:20-18.17 Identification
- 13:20-18.18 Installation instructions
- 13:20-18.19 Operating instructions
- 13:20-18.20 Samples for inspection and testing
- 13:20-18.21 Laboratory testing requirements
- 13:20-18.22 Verification

SUBCHAPTER 19. SEAT BELTS

- 13:20-19.1 General requirements
- 13:20-19.2 Application for product approval
- 13:20-19.3 Certificate of approval

SUBCHAPTER 20. NEW TIRES

- 13:20-20.1 Adoption of Vehicle Equipment Safety Commission regulation
- 13:20-20.2 Approval
- 13:20-20.3 Requirements for product approval
- 13:20-20.4 Procedure for securing approval
- 13:20-20.5 Certificate of approval
- 13:20-20.6 Revocation of approval
- 13:20-20.7 Scope
- 13:20-20.8 Definitions
- 13:20-20.9 Preparation of tire for endurance test
- 13:20-20.10 Equipment
- 13:20-20.11 Procedure
- 13:20-20.12 Test results
- 13:20-20.13 Preparation of tire for breaking energy test
- 13:20-20.14 Breaking energy test equipment
- 13:20-20.15 Procedure
- 13:20-20.16 Preparation of tire for high speed test
- 13:20-20.17 High speed test equipment
- 13:20-20.18 Procedure
- 13:20-20.19 High speed test results
- 13:20-20.20 Preparation of tire-wheel assembly for bead unseating test
- 13:20-20.21 Bead unseating test equipment
- 13:20-20.22 Bead unseating test procedure
- 13:20-20.23 Resistance to bead unseating
- 13:20-20.24 Identification
- 13:20-20.25 Report
- 13:20-20.26 Table 1
- 13:20-20.27 Table 2
- 13:20-20.28 Figure 1
- 13:20-20.29 Figure 2
- 13:20-20.30 Figure 3

SUBCHAPTER 21. RETREAD TIRES

- 13:20-21.1 Regrooved and recut tires
- 13:20-21.2 Approval
- 13:20-21.3 Approval procedure
- 13:20-21.4 Waiver
- 13:20-21.5 Notice of approval
- 13:20-21.6 Withdrawal of approval

SUBCHAPTER 22. BRAKE LININGS

- 13:20-22.1 Standards and specifications
- 13:20-22.2 Approval
- 13:20-22.3 Requirements for product approval
- 13:20-22.4 Procedure for securing approval
- 13:20-22.5 Notice of approval
- 13:20-22.6 Withdrawal of approval
- 13:20-22.7 Brake linings manufactured prior to effective date

SUBCHAPTER 23. FASTENING LOADS ON COMMERCIAL FLAT BED VEHICLES

- 13:20-23.1 Definitions
- 13:20-23.2 Cargo securely fastened
- 13:20-23.3 Wood composition devices
- 13:20-23.4 Cables
- 13:20-23.5 High tension bands or wires
- 13:20-23.6 Fasteners
- 13:20-23.7 Working capacity; wear
- 13:20-23.8 Tiedown materials
- 13:20-23.9 Cargo shifting in transit
- 13:20-23.10 Cargo tipping in transit
- 13:20-23.11 Large materials
- 13:20-23.12 Center of gravity loading

ENFORCEMENT SERVICE

SUBCHAPTER 24. MOTORCYCLES

- 13:20-24.1 Approval of goggles
- 13:20-24.2 Goggles test procedure
- 13:20-24.3 Goggle approval requirements
- 13:20-24.4 Mark on goggles
- 13:20-24.5 Test procedure for face shields
- 13:20-24.6 Face shield approval requirements
- 13:20-24.7 Identification mark on face shield
- 13:20-24.8 Windscreen approval requirements
- 13:20-24.9 Mark on windscreen
- 13:20-24.10 Approval of helmets
- 13:20-24.11 Helmet approval specifications
- 13:20-24.12 Reflectorized surface on helmets
- 13:20-24.13 Identification label on helmets
- 13:20-24.14 Helmet straps
- 13:20-24.15 Test reports
- 13:20-24.16 Samples
- 13:20-24.17 Notice of approval
- 13:20-24.18 Temporary approval
- 13:20-24.19 Withdrawal of approval
- 13:20-24.20 Inspection of motorcycles
- 13:20-24.21 Motorcycle license plates and tabs

SUBCHAPTER 25. SAFETY GLAZING MATERIAL; OTHER EQUIPMENT

- 13:20-25.1 Letter requesting approval
- 13:20-25.2 Application for approval; report
- 13:20-25.3 Samples
- 13:20-25.4 Determination of approval
- 13:20-25.5 Safety glazing material approval procedure

SUBCHAPTER 26. SELF-INSPECTION OF CERTAIN CLASSES OF MOTOR VEHICLES

- 13:20-26.1 Applicability
- 13:20-26.2 Definitions
- 13:20-26.3 Inspection and maintenance
- 13:20-26.4 Unsafe operations
- 13:20-26.5 Inspection of motor vehicles
- 13:20-26.6 Motor vehicles declared "out-of-service"
- 13:20-26.7 Notice to owner or lessee
- 13:20-26.8 Damaged vehicles inspection
- 13:20-26.9 Vehicle condition report
- 13:20-26.10 Recommended forms
- 13:20-26.11 Required inspection and maintenance
- 13:20-26.12 Standards of inspection
- 13:20-26.13 Certification
- 13:20-26.14 Additional inspection
- 13:20-26.15 Penalties
- 13:20-26.16 State inspection required; time for inspection

SUBCHAPTER 27. (RESERVED)

SUBCHAPTER 28. INSPECTION OF NEW MOTOR VEHICLES

- 13:20-28.1 Purpose
- 13:20-28.2 Applicability
- 13:20-28.3 Definitions
- 13:20-28.4 Manufacturers' new vehicle inspection procedure
- 13:20-28.5 United States Transportation Department standards
- 13:20-28.6 Decal
- 13:20-28.7 Compliance
- 13:20-28.8 Evidence of compliance
- 13:20-28.9 Recommended practices and forms
- 13:20-28.10 Additional inspection
- 13:20-28.11 Determination of compliance by Director
- 13:20-28.12 Violation

SUBCHAPTER 29. MOBILE INSPECTION UNIT

- 13:20-29.1 Mobile Inspection Unit
- 13:20-29.2 Procedures
- 13:20-29.3 Penalty

SUBCHAPTER 30. SUPPLEMENTAL INSPECTION OF SCHOOL BUSES

- 13:20-30.1 Applicability
- 13:20-30.2 Definitions
- 13:20-30.3 Inspection and maintenance
- 13:20-30.4 Unsafe operations forbidden
- 13:20-30.5 Inspection of school buses in operation
- 13:20-30.6 Damaged vehicles inspection
- 13:20-30.7 Vehicle condition report by driver
- 13:20-30.8 Required practices
- 13:20-30.9 Standards; alteration of standards
- 13:20-30.10 Certification
- 13:20-30.11 Penalties

SUBCHAPTER 31. PRIVATE INSPECTION CENTER LICENSING

- 13:20-31.1 Restriction of initial licensing

SUBCHAPTER 32. MOTOR VEHICLE REINSPECTION CENTERS

- 13:20-32.1 License required; license classes
- 13:20-32.2 Service limits
- 13:20-32.3 Facilities and equipment
- 13:20-32.4 Applicant qualifications
- 13:20-32.5 Insurance required
- 13:20-32.6 License application, form, content and fee
- 13:20-32.7 License, display of; content
- 13:20-32.8 Identifying mark; reinspection center
- 13:20-32.9 Reinspection approval stickers
- 13:20-32.10 Records
- 13:20-32.11 Certification for reinspection
- 13:20-32.12 Denial, suspension and revocation of license
- 13:20-32.13 Advertising
- 13:20-32.14 Mechanic qualifications
- 13:20-32.15 Course requirements

SUBCHAPTER 33. ENFORCEMENT SERVICE; STANDARDS AND PROCEDURES TO BE USED BY LICENSED REINSPECTION CENTERS

- 13:20-33.1 General provisions; Classes I and II licensees
- 13:20-33.2 Credentials; Classes I and II licensees
- 13:20-33.3 License plates (identification marks); Classes I and II licensee
- 13:20-33.4 Steering and suspension and wheel alignment; Classes I and II licensees
- 13:20-33.5 Front parking lights; Classes I and II licensees
- 13:20-33.6 Glazing; Classes I and II licensees
- 13:20-33.7 Obstruction to driver's view; Classes I and II licensees
- 13:20-33.8 Horn; Classes I and II licensees
- 13:20-33.9 Windshield wipers; Classes I and II licensees
- 13:20-33.10 Clearance lights; Classes I and II licensees
- 13:20-33.11 Turn signals (direction signals) and hazard warning signals; Classes I and II licensees
- 13:20-33.12 Reflectors; Classes I and II licensees
- 13:20-33.13 Identification lights; Classes I and II licensees
- 13:20-33.14 Side-marker lights; Classes I and II licensees
- 13:20-33.15 Taillights (red rear lights) and plate light; Classes I and II licensees
- 13:20-33.16 Stoplights; Classes I and II licensees
- 13:20-33.17 Wheels; Classes I and II licensees
- 13:20-33.18 Tires; Classes I and II licensees
- 13:20-33.19 Exhaust system; Classes I and II licensees
- 13:20-33.20 Definitions; engine emissions terms; Classes I and II licensees
- 13:20-33.21 Prescribed vehicle emission reinspection test procedure; Classes I and II licensees
- 13:20-33.22 Equipment calibration; Classes I and II licensees
- 13:20-33.23 Engine repairs and diagnosis; Classes I and II licensees
- 13:20-33.24 Headlights; Classes I and II licensees
- 13:20-33.25 Rear view mirrors; Classes I and II licensees

- 13:20-33.26 Miscellaneous lights; Classes I and II licensees
- 13:20-32.27 Wiring and switching; Classes I and II licensees
- 13:20-33.28 Headlight beam indicator lights; Classes I and II licensees
- 13:20-33.29 Turn signal and hazard warning signal indicator lights; Classes I and II licensees
- 13:20-33.30 Antenna; Classes I and II licensees
- 13:20-33.31 Body; Classes I and II licensees
- 13:20-33.32 Bumpers; Classes I and II licensees
- 13:20-33.33 Doors; Classes I and II licensees
- 13:20-33.34 Fenders and fender flaps; Classes I and II licensees
- 13:20-33.35 Fuel system; Classes I and II licensees
- 13:20-33.36 Hood; Classes I and II licensees
- 13:20-33.37 Lettering; Classes I and II licensees
- 13:20-33.38 Ornaments; Classes I and II licensees
- 13:20-33.39 Pedals; Classes I and II licensees
- 13:20-33.40 Racks or carriers; Classes I and II licensees
- 13:20-33.41 Reflective tape; Classes I and II licensees
- 13:20-33.42 Seats; Classes I and II licensees
- 13:20-33.43 Seat belts; Classes I and II licensees
- 13:20-33.44 Shift indicator; Classes I and II licensees
- 13:20-33.45 Transmission; Classes I and II licensees
- 13:20-33.46 Television; Classes I and II licensees
- 13:20-33.47 Trunk lid; Classes I and II licensees
- 13:20-33.48 Service brakes (including equalization and pedal reserve); Classes I and II licensees
- 13:20-33.49 Parking brake; Classes I and II licensees
- 13:20-33.50 General information; Class III licensees
- 13:20-33.51 Credentials; Class III licensees
- 13:20-33.52 License plate (identification mark); Class III licensees
- 13:20-33.53 Steering, handlebars and suspension; Class III licensees
- 13:20-33.54 Windscreen, glazing and obstruction to vision; Class III licensees
- 13:20-33.55 Horn; Class III licensees
- 13:20-33.56 Windshield wipers; Class III licensees
- 13:20-33.57 Clearance lights; Class III licensees
- 13:20-33.58 Taillight (red rear light) and reflector and license plate light; Class III licensees
- 13:20-33.59 Stoplight; Class III licensees
- 13:20-33.60 Headlights; Class III licensees
- 13:20-33.61 Exhaust system; Class III licensees
- 13:20-33.62 Rear view mirrors; Class III licensees
- 13:20-33.63 Miscellaneous lights; Class III licensees
- 13:20-33.64 Wiring, switching and electrical equipment; Class III licensees
- 13:20-33.65 Beam indicator lights; Class III licensees
- 13:20-33.66 Miscellaneous items; Class III licensees
- 13:20-33.67 Tires; Class III licensees
- 13:20-33.68 Brakes (including pedal reserve, service brake equalization and parking brakes on three wheel motorcycles); Class III licensees
- 13:20-33.69 Helmets; Class III licensees
- 13:20-33.70 Goggles or face shields; Class III licensees
- 13:20-33.71 Seats; Class III licensees
- 13:20-33.72 (Reserved)
- 13:20-33.73 Foot rests; Class III licensees

SUBCHAPTER 34. IDENTIFYING MARKS

- 13:20-34.1 Definitions
- 13:20-34.2 Registration numbers reserved
- 13:20-34.3 Registration numbers excluded
- 13:20-34.4 Denials, suspension or revocation
- 13:20-34.5 Fees
- 13:20-34.6 Transfers to survivor
- 13:20-34.7 Reissue

SUBCHAPTER 35. INSPECTION OF STATE-OWNED VEHICLES BY THE CENTRAL MOTOR POOL

- 13:20-35.1 Application of subchapter
- 13:20-35.2 Inspection by the central motor pool
- 13:20-35.3 Inspection standards and frequency
- 13:20-35.4 Inspection decal
- 13:20-35.5 Facilities

- 13:20-35.6 Instruction of mechanics
- 13:20-35.7 Certification

SUBCHAPTER 36. SPECIAL NATIONAL GUARD PLATES

- 13:20-36.1 Application; certification; fees
- 13:20-36.2 Surrender of special plates

SUBCHAPTER 37. STANDARDS FOR MOTOR VEHICLES WITH MODIFIED CHASSIS HEIGHT

- 13:20-37.1 Modification of height of motor vehicle restricted; approval of the director
- 13:20-37.2 Requirements for motor vehicle approval
- 13:20-37.3 Standards for vehicles with modified height
- 13:20-37.4 Testing
- 13:20-37.5 Procedure for testing modified vehicles
- 13:20-37.6 Certificate of approval
- 13:20-37.7 Denied or revocation of approval

SUBCHAPTER 38. DIMENSIONAL STANDARDS FOR AUTOMOBILE TRANSPORTERS

- 13:20-38.1 Purpose
- 13:20-38.2 Definitions
- 13:20-38.3 Vehicle combination lengths; traditional automobile transporters; stinger-steered combination
- 13:20-38.4 Automobile transporter; load overhang
- 13:20-38.5 Drive-away saddlemount vehicle transporter combinations; drive-away saddlemount with fullmount vehicle transporter combinations; overall length
- 13:20-38.6 Application of Department of Transportation standards for 102-inch standard trucks to automobile transporters

SUBCHAPTER 39. SPECIAL REGISTRATION PLATES FOR NON-PROFIT ORGANIZATIONS

- 13:20-39.1 Purpose
- 13:20-39.2 Definitions
- 13:20-39.3 Qualifications for organization approval; final decision; right to suspend approval
- 13:20-39.4 Appointment of organization liaison
- 13:20-39.5 Certification of membership
- 13:20-39.6 Non-profit status
- 13:20-39.7 Notification of organization approval
- 13:20-39.8 Plate design
- 13:20-39.9 Fees; plate ordering; authenticity of membership
- 13:20-39.10 Denial, suspension or revocation

SUBCHAPTER 40. REFLECTORIZED REGISTRATION PLATES

- 13:20-40.1 Additional annual fee

SUBCHAPTER 41. PERSIAN GULF WAR COMMEMORATIVE LICENSE PLATES

- 13:20-41.1 Definition
- 13:20-41.2 Fees
- 13:20-41.3 Display
- 13:20-41.4 Complaints; investigations

SUBCHAPTER 42. PURPLE HEART EMBLEMS ON LICENSE PLATES

- 13:20-42.1 Use
- 13:20-42.2 Design
- 13:20-42.3 Materials
- 13:20-42.4 Placement

SUBCHAPTER 43. ENHANCED MOTOR VEHICLE INSPECTION AND MAINTENANCE PROGRAM

- 13:20-43.1 Definitions

- 13:20-43.2 Inspection requirements for motor vehicles; exempt motor vehicles; designation of collector motor vehicles
- 13:20-43.3 Inspection facilities
- 13:20-43.4 Federal motor vehicles
- 13:20-43.5 Motor vehicles registered in other states
- 13:20-43.6 Fleet motor vehicles
- 13:20-43.7 Test frequency
- 13:20-43.8 Tests for emissions
- 13:20-43.9 Inspection reports; emission-related repair forms
- 13:20-43.10 Reinspections
- 13:20-43.11 Inspection certificates of approval; inspection rejection stickers
- 13:20-43.12 Inspection extensions
- 13:20-43.13 Waivers; criteria for issuance; denial of warranty form; repair receipt form; waiver valid for inspection cycle; waiver issuance
- 13:20-43.14 On-road inspections; scope; inspection procedures; criteria for selecting vehicles; procedures upon inspection failure
- 13:20-43.15 Recall compliance procedures; purpose; applicability; notice to owner; recall compliance form; transfer of ownership; denial and suspension of registration
- 13:20-43.16 Registration denial; suspension of registration; motor vehicles not inspected by registration expiration date; motor vehicles which have failed inspection and have not been presented for reinspection
- 13:20-43.17 Inspector training and licensing; training administration; testing; application process; license fee; renewal of license; refresher training and testing; conflicts of interest
- 13:20-43.18 Suspension or revocation of inspector license; retraining and retesting; suspension pending hearing; schedule of penalties
- 13:20-43.19 Quality assurance; auditor training

SUBCHAPTER 44. PRIVATE INSPECTION FACILITY LICENSING

- 13:20-44.1 Purpose
- 13:20-44.2 Definitions
- 13:20-44.3 Scope; license required; vehicle classes; inspection services; fleet facilities
- 13:20-44.4 Initial application for a license
- 13:20-44.5 Applicant qualifications
- 13:20-44.6 Application and license fees
- 13:20-44.7 License renewals
- 13:20-44.8 Surrender of license
- 13:20-44.9 Facilities and equipment
- 13:20-44.10 Inspection certificates of approval
- 13:20-44.11 Responsibility of licensees
- 13:20-44.12 Notice and recordkeeping requirements
- 13:20-44.13 Records; inspection reports
- 13:20-44.14 Certification of inspection
- 13:20-44.15 Advertising
- 13:20-44.16 Storage rates
- 13:20-44.17 Additional violations
- 13:20-44.18 Emission inspector
- 13:20-44.19 Mechanic qualifications
- 13:20-44.20 Additional penalties; schedule of penalties
- 13:20-44.21 Investigations
- 13:20-44.22 Written notice of suspension or revocation or refusal to grant or renew license
- 13:20-44.23 Request for hearing
- 13:20-44.24 Hearing procedures
- 13:20-44.25 Limitations on issuance of license after suspension, revocation or refusal to grant or renew
- 13:20-44.26 License restoration

SUBCHAPTER 45. MOTOR VEHICLE EMISSION REPAIR FACILITY REGISTRATION

- 13:20-45.1 Purpose
- 13:20-45.2 Scope
- 13:20-45.3 Definitions
- 13:20-45.4 Initial application for registration

- 13:20-45.5 Applicant qualification
- 13:20-45.6 Registration fee
- 13:20-45.7 Registration renewals
- 13:20-45.8 Surrender of registration
- 13:20-45.9 Responsibility of registrants
- 13:20-45.10 Deceptive practices concerning emission-related repairs
- 13:20-45.11 Notice and recordkeeping requirements
- 13:20-45.12 Advertising
- 13:20-45.13 Storage rates
- 13:20-45.14 Additional violations
- 13:20-45.15 Mechanic qualifications
- 13:20-45.16 Repair technician; certification
- 13:20-45.17 Additional penalties
- 13:20-45.18 Investigations
- 13:20-45.19 Written notice of suspension or revocation or refusal to grant or renew registration
- 13:20-45.20 Request for hearing
- 13:20-45.21 Hearing procedures
- 13:20-45.22 Limitations on issuance of registration after suspension, revocation or refusal to renew
- 13:20-45.23 Registration restoration

SUBCHAPTER 1. (RESERVED)

Subchapter Historical Note

Subchapter 1, Enforcement Officer, was repealed by R.1989 d.518, effective October 2, 1989. See: 21 N.J.R. 1500(b), 21 N.J.R. 2176(a)

SUBCHAPTER 2. VEHICLE CONSTRUCTION

13:20-2.1 Vehicle construction and load

Pursuant to the provisions of N.J.S.A. 39:3-43 and 39:4-126, it is hereby declared that a vehicle is so constructed or loaded as to prevent the hand and arm signal from being visible, both to the front and rear, when the distance from the center of the top of the steering post to the left outside limit (or right in the case of a right-hand drive vehicle) of the body, cab or load exceeds 24 inches, or when the distance from the center of the top of the steering post to the rear limit of the body or load exceeds 14 feet. The latter measurement shall apply not only to a single vehicle, but also to any combination of vehicles.

13:20-2.2 Direction signals approval

By virtue of the provisions of N.J.S.A. 39:4-126, any vehicle or combination of vehicles constructed, loaded or capable of being loaded so as to exceed the dimensions set forth in N.J.A.C. 13:20-2.1 above shall be equipped with direction signals of a type approved by the Director of the Division of Motor Vehicles and said signals shall be in good working condition.

SUBCHAPTER 3. (RESERVED)

Subchapter Historical Note

Subchapter 3, Identification Lights, was filed and became effective prior to September 1, 1969. Subchapter 3 was repealed by R.1989 d.542, effective October 16, 1989. See: 21 N.J.R. 2460(a), 21 N.J.R. 3299(c). N.J.A.C. 13:24-5, Blue Emergency Warning Lights, was adopted as a new rule by R.1989 d.542, and regards the same subject matter as repealed 13:20, Subchapter 3.

SUBCHAPTER 4. POWER STEERING
INSTALLATION**Authority**

Unless otherwise expressly noted, all provisions of this Subchapter 4 of Chapter 20 were adopted by the Director, Division of Motor Vehicles, Department of Law and Public Safety, pursuant to authority delegated at N.J.S.A. 39:3-43.

13:20-4.1 Permitted power steering device

Any power steering device installed in a motor vehicle, offered for sale, sold or registered in the State of New Jersey, shall be of a type which will permit the continued use of the power steering mechanism under manual control in the event of the failure of the power unit.

13:20-4.2 Equipment approval

(a) All power steering equipment on motor vehicles offered for sale, sold or registered in the State of New Jersey, must be approved by the Director.

(b) A certificate of approval will be issued on presentation of satisfactory evidence that the equipment is of a type which can be used manually in the event of failure of the power unit. (Affidavits or statements from new car manufacturers to the above effect will be acceptable.)

SUBCHAPTER 5. MANUAL DOOR EQUIPMENT

Authority

Unless otherwise expressly noted, all provisions of this Subchapter 5 of Chapter 20 were adopted by the Director, Division of Motor Vehicles, Department of Law and Public Safety, pursuant to authority delegated at N.J.S.A. 39:3-43.

13:20-5.1 Purpose

The provisions of this Subchapter are promulgated for the purpose of preventing the entrapment of persons in motor vehicles.

13:20-5.2 Manual opening of doors

All vehicles registered in New Jersey must be equipped with some means of opening the doors manually from within the vehicle and vehicles must be equipped with outside door handles or equivalent devices.

13:20-5.3 Exceptions

This Subchapter shall not apply to vehicles used for the transportation of persons in the custody of law enforcement officers; provided, however, that in such cases, in addition to the driver, there is on duty in the vehicle at least one other person capable of opening the doors in the event of accident.

SUBCHAPTER 6. MUFFLER DEVICES

13:20-6.1 Prohibitory muffler devices

Pursuant to the provisions of N.J.S.A. 39:3-43, the use upon any motor vehicle of a straight exhaust pipe, or a muffler or mufflers lacking interior baffle plates or other effective muffling devices is expressly prohibited.

SUBCHAPTER 7. VEHICLE INSPECTION

Authority

Unless otherwise expressly noted, all provisions of this Subchapter 7 of Chapter 20 were adopted by the Director, Division of Motor Vehicles, Department of Law and Public Safety, pursuant to authority delegated at N.J.S.A. 39:8-2 and 39:8-4.

13:20-7.1 Adjustments, corrections or repairs

If inspections as required by N.J.S.A. 39:8-1 disclose the necessity of adjustments, corrections or repairs, it shall be incumbent upon the owner of such vehicle to have such adjustments, corrections or repairs made within 30 days.

As amended, R.1974 d.28, eff. February 1, 1974.

See: 6 N.J.R. 119(b).

As amended, R.1975 d.335, eff. November 3, 1975.

See: 7 N.J.R. 470(a), 7 N.J.R. 571(a)

13:20-7.2 Immediate repairs

When the nature of the defects found is such as in the judgment of the inspecting authority to require immediate repairs, such repairs shall be made within 48 hours.

13:20-7.3 (Reserved)

As amended, R.1982 d.364, eff. October 1, 1982.

See: 14 N.J.R. 918(a), 14 N.J.R. 1162(e).

Originally filed as an emergency adoption (R.1982 d.267) on August 2, 1982. Readopted as R.1982 d.364. Repealed period of commercial vehicle inspection.

13:20-7.4 Inspection period of passenger vehicles

The expiration of the windshield inspection sticker of each passenger vehicle shall be the last day of the month in which the vehicle registration expires. Each such vehicle shall be presented for inspection after registration has been renewed and prior to the expiration date shown on the windshield inspection sticker.

As amended, R.1982 d.364, eff. October 1, 1982.
See: 14 N.J.R. 918(a), 14 N.J.R. 1162(e).

Original filed as an emergency adoption (R.1982 d.267) on August 2, 1982. Readopted as R.1982 d.364. Deleted old text and added new text concerning "odd-even" inspection.

As amended, R.1983 d.294, eff. July 7, 1983.
See: 15 N.J.R. 1261(a).

Filed as emergency adoption on July 7, 1983. Repealed old odd-even system of motor vehicle inspection declared invalid by the Federal court and adopted prior rule.

As amended, R.1984 d.83, eff. April 12, 1984.
See: 15 N.J.R. 1261(a), 16 N.J.R. 738(a).

13:20-7.5 Temporary authorization certificate; form

(a) When a person registers a motor vehicle for the first time in New Jersey, whether new or used, and when a vehicle, new or used, is registered by a particular owner for the first time, the motor vehicle agent will issue to the registered owner a temporary authorization certificate.

(b) This certificate will be approximately postcard size, on postcard stock, and suitable for installing in the vehicle behind the windshield.

(c) It will read as follows:

STATE OF NEW JERSEY
DEPARTMENT OF LAW AND PUBLIC SAFETY
DIVISION OF MOTOR VEHICLES

INSPECTION
NOTICE

LICENSE PLATE NO	MAKE OF VEHICLE
------------------	-----------------

THIS VEHICLE MUST BE INSPECTED WITHIN 14 DAYS OF

DISPLAY THIS NOTICE IN LOWER RIGHT HAND CORNER OF WINDSHIELD

EPSL 8-7788 0 By _____ Agent

13:20-7.6 Inspection period

(a) The motor vehicle agent will fill in the registration number, the date on which the validation ends and will stamp his facsimile signature.

(b) The agent will then advise the owner that he must report for inspection within 14 days from the date of registration.

(c) Upon reporting for inspection, the validation certificate will be collected by the examiner at the inspection station and the proper sticker will be affixed to the windshield of the vehicle; provided, however, that the vehicle passes all New Jersey inspection requirements.

1. The vehicle shall be inspected and a sticker, which corresponds to the expiration date of the registration, shall be affixed to the vehicle provided, however, that the vehicle passes all New Jersey inspection requirements.

2. If the registration certificate for the vehicle has six months or less to run before the expiration date, a certificate shall be issued to the owner or driver of the vehicle, at the Station completing the initial inspection.

3. Presentation of such a certificate at an Inspection Station shall normally waive lane reinspection when accompanied by the vehicle and its renewed registration.

13:20-7.7 Initial passenger vehicle inspection procedure

(a) When a passenger vehicle, registered for the first time, is presented for the initial inspection, the following procedures will apply:

13:20-7.8 Initial inspection certificate data

The certificate will be approximately post card size, on post card stock, and will read as follows:

VI-24 (R5/71)

STATE OF NEW JERSEY
DEPARTMENT OF LAW & PUBLIC SAFETY
DIVISION OF MOTOR VEHICLES

Instructions Covering Registrations Expiring Within Six Months

TO the operator of vehicle bearing License Plate No.
Your vehicle has been inspected and approved. The windshield sticker shows the month that your registration expires and your vehicle must be presented for a new inspection.

Immediately after you renew your registration, please return to the EXIT end of the inspection station with the vehicle and the renewed registration where upon presentation of this certificate a new sticker will be affixed without further lane inspection. Obvious defects or damage shall be cause for the Station Supervisor to cancel this certificate and require a full lane inspection. The new sticker will show the number of the month in which the vehicle is next due for inspection.

NEW STICKER NO. Raphael J. Marini
DATE ISSUED Director

JP37529 BSC

13:20-7.9 Definitions

The following words and terms, as used in this Subchapter, shall have the following meanings, unless the context clearly indicates otherwise.

“Dealer” means the agent, distributor or authorized dealer of the manufacturer of the new motor vehicle, who has an established place of business under license issued by the Director.

“New motor vehicle” means only a newly manufactured motor vehicle, not previously registered, and bearing a Federal “Manufacturer’s Suggested Retail Price Label.”

13:20-7.10 Inspection procedure

(a) A dealer may present any new motor vehicle from his stock to a State Inspection Station to have such motor vehicle inspected with respect to mechanism, brakes and equipment.

(b) In the event that defects are found the periods for correction shall be as provided in Subchapter 7 of this Chapter.

(c) Approval stickers issued for dealer’s new vehicle shall be validated for a period of 90 days.

13:20-7.11 New vehicle purchaser procedure

(a) Within 14 days of the date of purchase and registration and within the 90-day validation period of the dealer approval sticker, the owner (registrant) of the vehicle may present the vehicle at the exit end of a State Inspection Station.

(b) The dealer approval sticker shall be replaced by an approval sticker corresponding with the expiration of the owner’s registration.

(c) No lane reinspection shall be required unless obvious defects or damage require cancellation of the reinspection waiver.

(d) A dealer approval sticker showing evidence of mutilation or tampering will not be honored.

13:20-7.12 Motor vehicle tires

(a) A tire shall be considered unsafe and shall be rejected for the following reasons:

1. Worn to the point where any part of the ply or cord is exposed (cracks, cuts, scuffs or snags deep enough to expose the cords or fabric are causes for rejection);
2. Any bump, bulge, knot or separation affecting the tire structure;
3. Any break repaired with a boot or patch;
4. Worn so that the tread wear indicators contact the road in any two adjacent major grooves, at three locations spaced approximately equally around the outside of the tire. Passenger car tires are constructed so that the tread wear indicators will not contact the road until the tread depth is less than 2/32 of an inch. It is also permissible to determine whether a passenger car tire has the minimum safe tread depth of 2/32 of an inch at the locations specified by using a tread depth gauge of a type calibrated in thirty-seconds of an inch and following the instructions furnished with such gauges.

(b) This provision shall take effect immediately.

R.1970 d.122, eff. Oct. 13, 1970.
See: 2 N.J.R. 67(d), 2 N.J.R. 94(a).

13:20-7.13 Expired inspection certificates

(a) The Director of the Division of Motor Vehicles may authorize and issue letters of extension to registered owners of New Jersey vehicles who are unable to complete the required vehicle inspection prior to the expiration of the current inspection period for:

1. Vehicles which have been temporarily out-of-State and which are now returning to New Jersey;
2. Vehicles which have been stored and not operated;
3. Vehicles which need major repairs which repairs cannot be completed during inspection period;
4. Vehicles which are unable to be inspected within the time required due to the licensee's health;
5. Vehicles which, for any other reason deemed valid by the Director, are unable to be inspected within the required period of time.

(b) Such extension is not intended for the purpose of allowing the operation of unsafe vehicles. This letter will permit the vehicle to be operated to a repair facility for correction of any defects or to the inspection station, or in the case of a person whose vehicle has been temporarily out of this State, to allow such person sufficient time within which to have that vehicle inspected at a New Jersey facility.

R.1972 d.136, eff. July 1, 1972.

See: 4 N.J.R. 130(b), 4 N.J.R. 196(b).

SUBCHAPTER 8. MOTOR VEHICLES TRANSPORTING FLAMMABLE LIQUIDS

Authority

Unless otherwise expressly noted, all provisions of this Subchapter 8 of Chapter 20 were adopted by the Director, Division of Motor Vehicles, Department of Law and Public Safety, pursuant to authority delegated at N.J.S.A. 39:3-43.

13:20-8.1 Scope and purpose

(a) These rules and regulations shall apply to all tank motor vehicles that are used for the transportation of normally stable flammable liquids or asphalt. It is intended to provide minimum requirements for the design, construction and operation of tank motor vehicles, their appurtenances, and certain features of tank motor vehicle chassis.

Note: Normally stable materials are those having the relative capacity to resist changes in their chemical composition which would produce violent reactions or detonations despite exposure to air, water, heat, including the normal range of conditions encountered in handling, storage or transportation. Unstable (reactive) flammable liquid shall mean a liquid which in the pure state or as commercially produced or transported will vigorously polymerize, decompose, condense or will become self-reactive under conditions of shock, pressure or temperature.

(b) Additional safeguards may be necessary for tank vehicles used for the transportation of flammable liquids having characteristics introducing additional factors such as high rates of expansion, instability, corrosiveness and toxicity.

(c) Attention is directed to the fact that cutback asphalts can have flash points in the range of Class I or Class II flammable liquids. Also liquids having a flash point higher than 200 degrees Fahrenheit, such as asphalt, may assume the characteristics of lower flash point liquids when heated. Under such conditions it shall be appropriate to apply the provisions of these standards otherwise specifically exempted.

(d) The requirements for aircraft fuel servicing tank vehicles are those contained in NFPA No. 407, Fueling Aircraft on the Ground.

13:20-8.2 Definitions

The following words and terms, when used in this Subchapter, shall have the following meanings unless the context clearly indicates otherwise.

“Approved” means approved by the Director of the Division of Motor Vehicles, Department of Law and Public Safety.

“Asphalt” includes other materials having similar characteristics when heated above ambient temperatures. (See N.J.A.C. 13:20-1.1(d).)

“Automotive service station” means that portion of a property where flammable liquids used as motor fuels are stored and dispensed from fixed equipment into the fuel tanks of motor vehicles.

“Baffle” means a perforated transverse partition of a cargo tank.

“Cargo tank” means any container having a liquid capacity in excess of 100 gallons used for carrying of flammable liquids or asphalt and mounted permanently or otherwise upon a tank vehicle. The term “cargo tank” does not apply to any container used solely for the purpose of supplying fuel for the propulsion of the tank vehicle upon which it is mounted.

“Compartment” means a liquid-tight division of a cargo tank.

“Director” means the Director of the Division of Motor Vehicles, Department of Law and Public Safety, or his authorized representative.

“Effective date” means the date upon which these rules and regulations become effective, fixed by law as the date of receipt for filing in the records of the Secretary of State.

“Flammable liquids” means liquids having a flash point below 200 degrees Fahrenheit and a vapor pressure not exceeding 40 psi absolute at 100 degrees Fahrenheit which, for the purpose of this specification shall be divided into three classes:

1. Class I shall include those having flash points at or below 20 degrees Fahrenheit.
2. Class II shall include those having flash points above 20 degrees Fahrenheit but at or below 70 degrees Fahrenheit.
3. Class III shall include those having flash points above 70 degrees Fahrenheit.

The flash point of flammable liquids having a flash point below 175 degrees Fahrenheit (79 degrees centigrade) shall be determined by the Standard Method of Test for Flash Point by means of the Tag Closed Tester, of the American Society for Testing Materials (A.S.T.M. D56-56).

The flash point of flammable liquids having a flash point of 175 degrees Fahrenheit or higher shall be determined by the Standard Method of Test for Flash Point by means of the Pensky-Martens Closed Tester of the American Society for Testing Materials (A.S.T.M. D93-52).

Vapor pressure shall be determined by the Standard Method of Test for Vapor Pressure of Petroleum Products (Reid Method) of the American Society for Testing Materials (A.S.T.M. D323-56).

“Head and bulkhead” means a liquid-tight transverse closure at the end of a cargo tank or between compartments of a cargo tank.

“Marine service station” means that portion of a property where flammable liquids used as motor fuels are stored and dispensed from fixed equipment on shore, piers, wharves, or floating docks into the fuel tanks of motor craft, and shall include all facilities used in connection.

“Tank vehicle” means any tank truck, tank full trailer or motor tractor and tank semitrailer combination.

“Tank truck” means any single self-propelled motor vehicle equipped with a cargo tank mounted thereon, and used for the transportation of flammable liquids or asphalt.

“Tank full trailer” means any vehicle with or without auxiliary motive power equipped with a cargo tank mounted thereon or built as an integral part thereof and used for the transportation of flammable liquids or asphalt and so constructed that practically all of its weight and load rests on its own wheels.

“Tank semitrailer” means any vehicle with or without auxiliary motive power, equipped with a cargo tank mounted thereon or built as an integral part thereof, and used for the transportation of flammable liquids or asphalt, and so constructed that, when drawn by a tractor by means of a fifth wheel connection, some part of its load and weight rests upon the towing vehicle.

Singular, plural may be used interchangeably and shall be so construed.

13:20-8.3 General provisions

Subject to the exceptions appearing in these regulations, no tank vehicle used for the transportation of flammable liquids may be operated unless the owner thereof has indicated his compliance with these regulations by securing a safety permit which will be issued only after the owner has made an affidavit to the effect that his vehicle complies with the following minimum requirements for the construction and operation of tank vehicles used for the transportation of flammable liquids.

13:20-8.4 Existing tank vehicles continuing in service; specification tanks of tank vehicles

Tanks of tank vehicles used for the transportation of flammable liquids which have been in service prior to the effective date hereof may be continued in service; provided, however, that they have been designed and constructed in accordance with the requirements of Specification No. 1001, 1937 edition, of the American Petroleum Institute, or in accordance with the requirements of specifications of the National Fire Protection Association, 1929 or 1933 edition, or with specifications MC 300, MC 301, MC 302 and MC 303 as contained in Motor Carrier Tariff No. 7 Interstate Commerce Commission Regulations.

13:20-8.5 Existing nonspecification tanks of tank vehicles

Tanks of tank vehicles used for the transportation of flammable liquids not meeting the requirements set forth in Section 8.4 of this Chapter, which shall have been in service prior to the effective date hereof, may be continued in service, provided that they fulfill the requirements as specified herein as to construction and that they be provided with the accessories as specified herein.

13:20-8.6 New tank vehicles

Except as provided in Section 8.7 (Novel tanks of tank motor vehicles) of this Chapter, every new tank of a tank vehicle acquired by a motor carrier on or after the effective date hereof, for the transportation of flammable liquids shall comply with the requirements set forth herein. A certificate from the manufacturer of the cargo tank, or from a competent testing agency, certifying that each such tank is designed and constructed in accordance with the requirements of the specifications shall be procured, and such certificate shall be retained in the files of the carrier during the time that such tank vehicle is employed in the transportation of flammable liquids by him. In lieu of this certificate, if the motor carrier himself elects to ascertain if any such tank fulfills the requirements of the specifications by his own test, he shall similarly retain the test data.

13:20-8.7 Novel tanks of tank motor vehicles

The Director of Motor Vehicles may, upon written request for authorization by a motor carrier, authorize the use of limited numbers, and for limited times, of new tank vehicles which fail to meet the requirements of specifications set forth herein; provided, however, that the design thereof has been approved by a nationally recognized authority such as National Bureau of Standards, National Fire Protection Association, Underwriters' Laboratories, or equal. The carrier shall also furnish satisfactory evidence that the construction of the vehicle conforms to the approved design.

13:20-8.8 Accident to vehicle; warning; no sparks or flame

In the event of an accident involving any motor vehicle transporting any flammable liquid every available means shall be employed to prevent individuals, other than those employed in the protection of persons or property or in the removal of hazards of wreckage, from congregating in the vicinity. Such means shall be employed to prevent smoking, to keep fires or flames away, to safeguard against the hazard present, and to warn other users of the highway.

13:20-8.9 Prevent leakage from spreading

Whenever any flammable liquid is escaping from a container, all practical means shall be taken to prevent such liquid from spreading over a wide area, from flowing into sewers and streams, and from becoming ignited.

13:20-8.10 Disposition of contents of cargo tank when unsafe to continue

In the event of a leak in a cargo tank of such character as to make further transportation unsafe, the leaking vehicle should be removed from the traveled portion of the highway; and every available means employed for the safe disposal of the leaking liquid by preventing, so far as practicable, its spread over a wide area, such as by digging trenches to drain to a hole or depression in the ground, diverting the liquid away from streams or sewers if possible, or catching the liquid in containers if practicable. Smoking and the lighting of cigarettes, cigars, or pipes in the vicinity is prohibited, and fires or flames in the vicinity of leaking cargo tank must be extinguished.

13:20-8.11 Transfer of flammable liquids en route

No flammable liquid shall be transferred from one container to another, or from one motor vehicle to another vehicle, or from another vehicle to a motor vehicle, on any public highway, street, or road, except in case of emergency. In such cases approved warning signals shall be set out in the manner prescribed for disabled or stopped motor vehicles by motor vehicle regulations. In any event, all practicable means, in addition to those hereinbefore prescribed, shall be taken to protect and warn other users of the highway against the hazard involved in any such transfer, or against the hazard occasioned by the emergency making such transfer necessary. Nothing contained in this Section

shall be so construed as to prohibit the fueling of machinery or vehicles used in road construction and maintenance.

13:20-8.12 Transportation of leaking cargo tanks

A leaking cargo tank may only be transported the minimum distance necessary to reach a place where the contents of the tank or compartment may be disposed of with safety. Every available means must be utilized to prevent the leakage or spillage of the liquid upon the highway.

13:20-8.13 Smoking by tank vehicle drivers

Smoking by tank vehicle drivers or their helpers is prohibited while they are driving, making deliveries, filling, or making any repairs to tank vehicles.

13:20-8.14 Basic design

(a) Design of the tank vehicle shall give engineering consideration to the structural relationship between the cargo tank, the propulsion equipment and the supporting members if any, with due regard to the weight and temperature of the cargo, road performance, braking and required ruggedness. The metal thicknesses specified in this Section are minimum thicknesses dictated by the structure of the tank itself, and it may be necessary that these thicknesses be increased where the tank shell is to be subjected to additional stress.

(b) Any tank vehicle designed or used for transporting materials at liquid temperatures above ambient temperature shall have a red warning sign permanently attached to the vehicle containing at least the following:

"Maximum allowable cargo temperature is ___ degrees F."

This maximum allowable cargo temperature shall be specified by the manufacturer of the vehicle.

(c) Cargo tanks used for transporting flammable liquids with a vapor pressure of 18 psia or over at 100 degrees Fahrenheit shall be constructed in accordance with provisions of Sections 8.15 (Cargo tanks, piping and connections designed for flammable liquids having a vapor pressure of 18 psia or over at 100 degrees Fahrenheit) or 8.16 (Cargo tanks, piping and connections designed for flammable liquids having a vapor pressure under 18 psia at 100 degrees Fahrenheit) of this Chapter.

(d) Cargo tanks used for transporting flammable liquids with a vapor pressure under 18 psia at 100 degrees Fahrenheit shall be constructed in accordance with the provisions of Section 8.15 (Cargo tanks, piping and connections designed for flammable liquids having a vapor pressure of 18 psia or over at 100 degrees Fahrenheit).

(e) The material used in the construction of the cargo tanks shall be compatible with the chemical characteristics of the flammable liquid to be transported.

Note: In case of doubt, the supplier or producer of the flammable liquid or other competent authority should be consulted as to the suitability of the material of construction to be used.

13:20-8.15 Cargo tanks, piping and connections designed for flammable liquids having a vapor pressure of 18 psia or over at 100 degrees Fahrenheit

Cargo tanks, piping and connections designed for flammable liquids having a vapor pressure of 18 psia or over at 100 degrees Fahrenheit shall be built in accordance with Specification MC 304 or MC 330 of Part 78 of Title 49, Code of Federal Regulations (Regulations of the Interstate Commerce Commission) or in accordance with Division III of the Standard for the Storage and Handling of Liquefied Petroleum Gases, NFPA No. 53.

13:20-8.16 Cargo tanks, piping and connections designed for flammable liquids having a vapor pressure under 18 psia at 100 degrees Fahrenheit

Cargo tanks, piping and connections designed for flammable liquids having a vapor pressure under 18 psia at 100 degrees Fahrenheit shall be built in accordance with the following specifications of Sections 8.17 through 8.20 of this Chapter.

13:20-8.17 Cargo tanks constructed of mild steel

(a) All sheets for such cargo tanks shall be of mild steel to meet the following requirements:

1. Yield Point, minimum 25,000 pounds per square inch;
2. Ultimate Strength, minimum 45,000 pounds per square inch;
3. Minimum Elongation, standard two-inch sample 20 per cent.

(b) The minimum thickness of tank sheets shall be limited by the volume capacity of the tank expressed in terms of gallons per inch of length, and by the distance between bulkheads, baffles, or other shell stiffeners, as well as by the radius of shell curvature in case of shell sheets. Thickness of exterior head sheets shall never be less than the maximum requirements for shell sheets in any specific unit.

13:20-8.18 Bulkhead, baffle and shell sheets

MINIMUM THICKNESS OF HEAD, BULKHEAD AND BAFFLE SHEETS

Heads, Bulkheads, or Baffles Volume Capacity of Tank in Gallons Per Inch of Length Manufacturers Std. Gage No.	Mild Steel (Dished, Corrugated, Reinforced or Rolled)			
	10 or Less	Over 10 to 14	Over 14 to 18	Over 18
	14	13	12	11

MINIMUM THICKNESS OF SHELL SHEETS

Volume Capacity of Tank in Gallons Per Inch of Length	Mild Steel Distance Between Attachments of Bulkheads, Baffles or Other Shell Stiffeners					
	36 inches or less		Over 36 inches to 54 inches		Over 54 inches	
	Gage* No.	Approx. Thick. Deci- mals of in.	Gage* No.	Approx. Thick. Deci- mals of in.	Gage* No.	Approx. Thick. Deci- mals of in.
Maximum Shell Radius of less than 70 inches:						
10 gallons or less	14	0.0747	14	0.0747	14	0.0747
Over 10 to 14 gallons	14	0.0747	14	0.0747	13	0.0897
Over 14 to 18 gallons	14	0.0747	13	0.0897	12	0.1046
Over 18 gallons	13	0.0897	12	0.1046	11	0.1196
Maximum Shell Radius of 70 inches or more, but less than 90 inches:						
10 gallons or less	14	0.0747	14	0.0747	13	0.0897
Over 10 to 14 gallons	14	0.0747	13	0.0897	12	0.1046
Over 14 to 18 gallons	13	0.0897	12	0.1046	11	0.1196
Over 18 gallons	12	0.1046	11	0.1196	10	0.1345
Maximum Shell Radius of 80 inches or more, but less than 125 inches:						
10 gallons or less	14	0.0747	13	0.0897	12	0.1046
Over 10 to 14 gallons	13	0.0897	12	0.1046	11	0.1196
Over 14 to 18 gallons	12	0.1046	11	0.1196	10	0.1345
Over 18 gallons	11	0.1196	10	0.1345	9	0.1495
Maximum Shell Radius of 125 inches or more:						
10 gallons or less	13	0.0897	12	0.1046	11	0.1196
Over 10 to 14 gallons	12	0.1046	11	0.1196	10	0.1345
Over 14 to 18 gallons	11	0.1196	10	0.1345	9	0.1495
Over 18 gallons	10	0.1345	9	0.1495	8	0.1685

*Manufacturers Standard Gage and approximate equivalent thickness in decimals of inch.

13:20-8.19 Cargo tanks constructed of low alloy low carbon (high tensile) steel and stainless steel

(a) All low alloy low carbon (high tensile) steel sheets for such cargo tanks shall meet the following requirements:

1. Yield Point, minimum 45,000 pounds per square inch;
2. Ultimate Strength, minimum 60,000 pounds per square inch;
3. Minimum Elongation, standard two-inch sample 25 per cent.

(b) All stainless steel sheets for such cargo tanks shall meet the following minimum requirements:

1. Yield Point, minimum 32,000 pounds per square inch;
2. Ultimate Strength, minimum 75,000 pounds per square inch;
3. Minimum Elongation, standard two-inch sample 20 per cent.

(c) Thickness of high tensile and stainless steel sheets.

The minimum thickness of high tensile and stainless steel tank sheets shall be limited by the volume capacity of the tank expressed in terms of gallons per inch of length; and by the distance between bulkheads, baffles, or other shell sheets; as follows:

Low Alloy Low Carbon (High Tensile) Steel and Stainless Steel Sheets

MINIMUM THICKNESS OF HEAD, BULKHEAD AND BAFFLE SHEETS

MINIMUM THICKNESS OF HEAD, BULKHEAD AND BAFFLE SHEETS

Heads, Bulkheads, or Baffles Volume Capacity of Tank in Gallons Per Inch of Length Manufacturers Std. Gage No.	(Dished, Corrugated, Reinforced or Rolled)			
	10 or Less	Over 10 to 14	Over 14 to 18	Over 18
	15	14	13	12

MINIMUM THICKNESS OF SHELL SHEETS
Low Alloy Low Carbon (High Tensile) Steel and Stainless Steel

Volume Capacity of Tank in Gallons Per Inch of Length	Distance Between Attachments of Bulkheads, Baffles or Other Shell Stiffeners					
	36 inches or less		Over 36 inches to 54 inches		Over 54 inches	
	Gage** No.	Approx. Thick. Decimals of in.	Gage** No.	Approx. Thick. Decimals of in.	Gage** No.	Approx. Thick. Decimals of in.
Maximum Shell Radius of less than 70 inches:*						
10 gallons or less	16	0.0588	16	0.0588	15	0.0673
Over 10 to 14 gallons	16	0.0588	15	0.0673	14	0.0747
Over 14 to 18 gallons	15	0.0673	14	0.0747	13	0.0897
Over 18 gallons	14	0.0747	13	0.0897	12	0.1046
Maximum Shell Radius of 70 inches or more, but less than 90 inches:*						
10 gallons or less	16	0.0588	15	0.0673	14	0.0747
Over 10 to 14 gallons	15	0.0673	14	0.0747	13	0.0897
Over 14 to 18 gallons	14	0.0747	13	0.0897	12	0.1046
Over 18 gallons	13	0.0897	12	0.1046	11	0.1196
Maximum Shell Radius of 90 inches or more, but less than 125 inches:*						
10 gallons or less	15	0.0673	14	0.0747	13	0.0897
Over 10 to 14 gallons	14	0.0747	13	0.0897	12	0.1046
Over 14 to 18 gallons	13	0.0897	12	0.1046	11	0.1196
Over 18 gallons	12	0.1046	11	0.1196	10	0.1345
Maximum Shell Radius of 125 inches or more:*						
10 gallons or less	14	0.0747	13	0.0897	12	0.1046
Over 10 to 14 gallons	13	0.0897	12	0.1046	11	0.1196
Over 14 to 18 gallons	12	0.1046	11	0.1196	10	0.1345
Over 18 gallons	11	0.1196	10	0.1345	9	0.1495

*If other than circular cross section, the radius used shall be the maximum for that portion of the cross section under consideration.

**Manufacturers Standard Gage and approximate equivalent thickness in decimals of inch.

13:20-8.20 Cargo tanks constructed of aluminum alloys for high strength welded construction

(a) All sheets for shell, heads and bulkheads of such cargo tanks shall be of aluminum alloys GR20A (5052 commercial designation), GM31A (5454 commercial designation), GR40A (5154 commercial designation) or GM40A (5086 commercial designation), conforming to American Society for Testing Materials Specification B209-57T.

(b) All heads, bulkheads, baffles and other shell stiffeners may use 0 temper (annealed) or stronger tempers. All shells shall be of H32 temper or 334 temper except that when shell thicknesses of 0.250 inch or thicker are used, the H112 temper is additionally permitted.

(c) The minimum nominal thicknesses of tank sheets shall be limited by the volume capacity of the tank, expressed in terms of gallons per inch of length; and by the distance between bulkheads, baffles, or other shell stiffeners, as well as by the radius of shell curvature in the case of shell sheets. Thickness of exterior head sheets shall never be less than the maximum requirements for shell sheets.

(d) When aluminum is used for cargo tanks intended to transport cargoes at liquid temperatures above 250 degrees Fahrenheit the minimum thicknesses in the following tables shall be increased by one per cent for each 10 degree Fahrenheit or portion thereof above 250 degrees Fahrenheit. When the liquid temperatures are above 500 degrees Fahrenheit there shall be an additional one per cent for each 10 degrees Fahrenheit or portion thereof above 500 degrees Fahrenheit. Aluminum shall not be used for cargo tanks transporting cargoes at temperatures above 550 degrees Fahrenheit.

MINIMUM THICKNESS OF HEAD
BULKHEAD AND BAFFLE SHEETS

MINIMUM THICKNESS OF HEAD, BULKHEAD
AND BAFFLE SHEETS

Aluminum Alloys GR20A, GM31A, GR40A, and GM40A

Heads, Bulkheads, or Baffles Volume Capacity of Tank in Gallons per Inch of Length Thickness in Decimals of Inch	10 or Less	Over 10 to 14	Over 14 to 18	Over 18
	.096	.109	.130	.151

MINIMUM THICKNESS OF SHELL SHEETS

Aluminum Alloys GR20A, GM31A, GR40A and GM40A

Distance Between Attachments of Bulkheads,
Baffles or Other Shell Stiffeners

Volume Capacity of Tank in Gallons Per Inch of Length	36 inches or Less	Over 36 inches to 54 inches	Over 54 inches
Inch Decimal Thickness for Maximum Shell Radius of Less than 70 inches:			
10 gallons or less	.087	.087	.096
Over 10 to 14 gallons	.087	.096	.109
Over 14 to 18 gallons	.096	.109	.130
Over 18 gallons	.109	.130	.151
Inch Decimal Thickness for Maximum Shell Radius of 70 inches or more, but less than 90 inches:			
10 gallons or less	.087	.096	.109
Over 10 to 14 gallons	.096	.109	.130
Over 14 to 18 gallons	.109	.130	.151
Over 18 gallons	.130	.151	.173
Inch Decimal Thickness for Maximum Shell Radius of 90 inches or more, but less than 125 inches:			
10 gallons or less	.096	.109	.130
Over 10 to 14 gallons	.109	.130	.151
Over 14 to 18 gallons	.130	.151	.173
Over 18 gallons	.151	.173	.194
Inch Decimal Thickness for Maximum Shell Radius of 125 inches or more:			
10 gallons or less	.109	.130	.151
Over 10 to 14 gallons	.130	.151	.173
Over 14 to 18 gallons	.151	.173	.194
Over 18 gallons	.173	.194	.216

13:20-8.21 Joints

Joints shall be welded in accordance with recognized good practice and the efficiency of any joint shall be not less than 85 per cent of that of the adjacent metal in the tank.

13:20-8.22 Combination steel sheets

Mild steel sheets as specified in Section 8.17 (Cargo tanks constructed of mild steel) of this Chapter may be used in combination with high tensile steel sheets or stainless steel sheets as specified in Section 8.18 (Bulkhead, baffle and shell sheets) of this Chapter in the construction of a single tank, provided each material, where used, shall comply with the minimum requirements for the material used in the construction of that section of the tank. Whenever stainless

steel sheets are used in combination with sheets of other types of steel, joints made by welding shall be formed by the use of stainless steel electrodes or filler rods on condition that the stainless steel electrodes or filler rods used in the welding be suitable for use with the grade of stainless steel concerned, according to the recommendations of the manufacturer of the stainless steel electrodes or filler rods.

13:20-8.23 Welded aluminum joints

In cargo tanks constructed of aluminum alloys, all joints in and to tank shells, heads and bulkheads shall be welded. All welded aluminum joints shall be made in accordance with recognized good practice, and the efficiency of a joint shall not be less than 85 per cent of the annealed properties

of the material in question. Aluminum alloys for high strength welded construction shall be joined by an inert gas arc welding process using filler metals R-GR40A, E-GR40A (5154 alloy) and R-GM50A, E-GM50A (5356 alloy) as conforming to American Society for Testing Materials Specification No. B285-57T (American Welding Society Specification No. A5. 10-57).

13:20-8.24 Compartmentalized cargo tanks

(a) Every cargo tank having a total capacity in excess of 3000 gallons and used for the distribution of Class I and Class II flammable liquids to automotive and marine service stations to which the public is invited shall be divided into compartments, no one of which shall exceed 2500 gallons. A design tolerance of ten percent shall be allowed for capacities of individual compartments or tanks.

(b) Bulkheads or compartments shall not be required in any cargo tank used for transportation service, regardless of total capacity, provided such cargo tank is not used for the delivery of flammable liquids to service stations or other premises to which the public is invited. Bulkheads or compartments shall not be required in any cargo tank used for asphalt service.

(c) Every cargo tank, and every compartment over 90 inches in length, except those used in asphalt service, shall be provided with baffles, the number of which shall be such that the linear distance between any two adjacent baffles, or between any tank head or bulkhead and the baffles nearest it, shall in no case exceed 60 inches.

(d) The cross-sectional area of each baffle shall be not less than 80 per cent of the cross-sectional area of the tank and the thickness of such baffle shall be not less than that required for heads and bulkheads of the cargo tank in which installed.

(e) Cargo tanks with compartments carrying flammable liquids of different classes shall be provided with an air space between compartments and this air space shall be equipped and maintained with drainage facilities operative at all times.

13:20-8.25 Test leaks

At the time of manufacture every cargo tank shall be tested by a minimum air or hydrostatic pressure of three pounds per square inch applied to each compartment, or to the whole tank if it be not divided into compartments. Such pressure shall be maintained for a period of at least five minutes, during which, if the test is by air pressure, the entire exterior surface of all the joints shall be coated with a solution of soap and water, heavy oil or other material suitable for the purpose, foaming or bubbling of which will indicate the presence of leaks. Hydrostatic pressure, if used, shall be gaged at the top of the tank; and the tank shall be inspected at the joints for the issuance of liquid to indicate leaks. Any leakage discovered by either of the methods above described, or by any other method shall be deemed as evidence of failure to meet the requirements of this specification.

13:20-8.26 Tank outlets

Outlets shall be substantially made and so attached to the tank.

13:20-8.27 Drawoff valves

Drawoff valves and faucets shall have discharge ends threaded, or they shall be so designed as to permit being tightly connected to hose extending to fill pipe.

13:20-8.28 Vents

(a) Each cargo tank or compartment, except those used in asphalt service, shall be provided with a vacuum and pressure-operated vent with a minimum effective opening of 0.44 square inch, and shall also be provided with an emergency venting facility so constructed as to provide a minimum free-venting opening having a net area in square inches equal to 1.25 plus 0.0025 times the capacity of the cargo tank or compartments in gallons. If the emergency venting facility operates in response to elevated temperatures, the critical temperature for such operation shall not exceed 200 degrees Fahrenheit.

(b) Each cargo tank used in asphalt service shall be provided with a vent having an effective opening at least equivalent to a nominal two-inch pipe.

13:20-8.29 Manholes

Each cargo tank for asphalt service shall be provided with a manhole at least 16 inches in diameter designed to relieve internal pressure at between two and three pounds per square inch gage or an equivalent relief device.

13:20-8.30 Shutoff valves

(a) The outlets of each cargo tank or compartment used for transportation of Class I and Class II flammable liquids, and trucks constructed hereafter for transportation of Class III flammable liquids having a viscosity less than 45 seconds Saybolt Universal at 100 degrees Fahrenheit, shall be equipped with a reliable and efficient shutoff valve located inside the shell; or in the sump when it is an integral part of the shell; and designed so that the valve must be kept closed except during loading and unloading operations.

Note: The 45-second viscosity limit is included for the purposes of requiring internal valves when transporting free-flowing distillate oils, such as kerosene, diesel oil and domestic heating oil, and of excluding this requirement when transporting viscous oils such as residual fuel oil, bunker fuel oil, and asphalt products.

(b) The operating mechanism for the valve shall be provided with a secondary control, remote from the fill openings and discharge faucets, for use in the event of accidents or fire during delivery operations.

(c) The control mechanism shall be provided with a fusible section which will permit valves to close automatically in case of fire.

(d) In every case there shall be provided, between the shutoff valve seat and discharge faucet, a shear section which will break under strain unless the discharge piping is so arranged as to afford the same protection and leave the shutoff valve seat intact.

(e) The outlets of each cargo tank used for the transportation of liquids having a viscosity equal to or greater than 45 seconds Saybolt Universal at 100 degrees Fahrenheit shall be equipped with a suitable shutoff valve, located internally, designed so that the valve will remain operable if the external connection is sheared off or a front or rear-head mounted valve securely reinforced and protected against shock or road hazards.

13:20-8.31 Overflow protection

Overflow protection for asphalt tank vehicles shall be provided in the form of reservoirs or flashing around fill and vent pipes. Overflow and drain pipes shall have thicknesses heavier than the tank shell and shall be designed so that hot asphalt will not spill onto tires, brakes, burner equipment or vehicle's exhaust system.

13:20-8.32 Marking tank vehicles

(a) Every tank vehicle used for the transportation of any flammable liquid, regardless of the quantity being transported, or whether loaded or empty, shall be conspicuously and legibly marked on each side and the rear thereof, in letters at least three inches high on a background of sharply contrasting color, optionally, as follows:

1. With a sign or lettering on the vehicle with the word "FLAMMABLE"; or,
2. With the common name of the flammable liquid being transported; or,
3. With the name of the carrier or his trademark when and only when such name or mark plainly indicates the flammable nature of the cargo.

(b) Every sign or lettering required by Subsection (a) of this Section shall be removed from or covered on any vehicle to which it is attached or affixed when such vehicle is not transporting the flammable liquid for which the sign is appropriate, except that no such sign or lettering is required to be removed or covered when such vehicle is used exclusively in the transportation of any flammable liquid for which the sign or lettering is appropriate.

13:20-8.33 Construction and equipment of tank vehicle chassis assembly and appurtenances

(a) Tires. All tank motor vehicles shall be equipped with rubber tires on all wheels, and tank trucks and tank trailers,

excepting tank semitrailers, shall be operated on a minimum of four wheels.

(b) Assembly. Every cargo tank shall be adequately supported upon and securely attached to or be a part of the tank vehicle upon which it is carried.

(c) Static protection. Cargo tanks, and vehicle chassis, shall be electrically bonded. Provisions shall be made in the tank structure of the vehicle for the bonding of vehicle to the fill pipe during truck loading operations.

(d) Protection against collision. Draw-off valves or faucets projecting beyond the frame at the rear of a tank vehicle shall be adequately protected against collision by bumpers or similar means.

(e) Overturn protection. All closures for filling openings, shall be protected from damage in the event of overturning of the motor vehicle, by being enclosed within the body of the tank or a dome attached thereto, or by the use of suitable metal guards securely attached to the tank or frame of the motor vehicle.

(f) Lighting. No lighting device other than electric lights shall be used on tank vehicles. Lighting circuits shall have suitable over-current protection (fuses or automatic circuit breakers). The wiring shall have sufficient carrying capacity and mechanical strength, and shall be secured, insulated, and protected against physical damage, in keeping with recognized good practice.

13:20-8.34 Fuel system

(a) Fuel tanks. Fuel tanks shall be so designed, constructed, and installed as to present no unusual hazard, and shall be so arranged as to vent during filling operations and permit drainage without removal from their mountings.

(b) Fuel tanks for the vehicle engine and fuel tanks for the burners on asphalt trucks shall be located remotely from the burner or protected by a noncombustible shield from the burner to prevent flashback.

(c) Fuel-feed systems. All portions of the fuel-feed system, including carburetor, pumps, and all auxiliary mechanisms and connections shall be constructed and installed in a workmanlike manner, and so constructed and located as to minimize the fire hazard, with no readily combustible materials used therein, and shall, except for diesel fuel connections, be well separated from the engine exhaust system. A pressure-release device shall be provided where necessary. The fuel feed lines shall be made of materials not adversely affected by the fuel to be used or by other materials likely to be encountered, of adequate strength for their purpose, well secured to avoid chafing or undue vibration, having a readily accessible and reliable shut-off valve or stop-cock. Joints depending upon solder for mechanical strength and liquid tightness shall not be used in the fuel system at or near the engine, or its accessories, unless the solder has a melting

point of not less than 340 degrees Fahrenheit, or unless a self-closing, thermally controlled valve set to operate at not exceeding 300 degrees Fahrenheit, or other equivalent automatic device, shall be installed in the fuel line on the fuel-tank side of such joint.

13:20-8.35 Exhaust system

(a) The exhaust system, including muffler (or silencer) and exhaust line shall have ample clearance from the fuel system and combustible materials, and shall not be exposed to accumulations of grease, oil or gasoline.

(b) The exhaust system, including all units, shall be constructed and installed in a workmanlike manner. A muffler (or silencer) cut-out shall not be used.

13:20-8.36 Full trailers and semi-trailers

(a) Trailers shall be firmly and securely attached to the vehicle drawing them in a manner conforming with recognized good practice.

(b) Every tank vehicle shall be equipped with brakes on all wheels. All brakes on a combination of tank vehicles shall be controlled by the driver of the drawing vehicle. Every tank trailer and tank semi-trailer shall be equipped with brakes of such a character as to be automatically applied upon break-away from the towing vehicle and shall be designed to stop and hold such vehicle for a reasonable period of time after breakaway. In any combination of tank vehicles the brakes shall be of such design that the brakes on the towed vehicles may be applied in approximate synchronism or previous to the brakes on the towing vehicle.

(c) Trailer connections shall be such as to prevent the towed vehicle from whipping or swerving from side to side dangerously or unreasonably and shall cause the trailer to follow substantially in the path of the towing vehicle.

13:20-8.37 Fire extinguishers

(a) Each tank vehicle shall be provided with at least one portable fire extinguisher having at least a 12-B,C rating or when more than one is provided, each extinguisher shall have at least a 6-B rating. Ratings shall be in accordance with the standard for Installation, Maintenance and Use of Portable Fire Extinguishers, No. 10.

(b) Fire extinguishers shall be kept in good operating condition at all times, and they shall be located in an accessible place on each tank vehicle.

13:20-8.38 Auxiliary internal combustion engines

(a) Internal combustion engines, other than those providing propulsive power, installed or carried upon a tank vehicle transporting Class I and Class II flammable liquids for the purpose of providing power for the operation of pumps or other devices, shall meet the following requirements:

1. The engine air intake shall be equipped with an effective flame arrester, or an air cleaner having effective flame arrester characteristics, substantially installed and capable of preventing emission of flame from the intake side of the engine in event of backfiring.

2. The fuel system shall be so located or constructed as to minimize the fire hazard. If the fuel tank is located above or immediately adjacent to the engine, suitable shielding shall be provided to prevent spillage during the filling operation, or leakage from the tank or fuel system, from coming in contact with the engine or any parts of the ignition and exhaust systems. All parts of the fuel system shall be constructed and installed in a workmanlike manner.

3. Pumps and other appurtenances carrying or containing flammable liquids shall be so located in relation to the engine that spillage or leakage from such parts shall be prevented from coming in contact with the engine or any parts of the ignition and exhaust system, or adequate shielding shall be provided to attain the same purpose. The engine cooling fan shall be so positioned, rotated or shielded as to minimize the possibility of drawing flammable vapors toward the engine.

4. When the engine is located in a position where spillage from the cargo tank or its appurtenances or from side racks might constitute a hazard, suitable shielding shall be provided to prevent such spillage from contacting the engine or engine exhaust system and for draining such spillage away from the vicinity of the engine.

5. Where the engine is carried within an enclosed space adequate provision shall be made for air circulation at all times, to prevent accumulation of explosive vapors and to avoid overheating.

6. The exhaust system shall be substantially constructed and installed and free from leaks. The exhaust line and muffler shall have adequate clearance from combustible materials and the exhaust gases shall be discharged at a location which will not constitute a hazard. When engines are carried within an enclosed space (paragraph 5 of this Section) the exhaust gases shall be discharged outside of each closed space.

7. The ignition wiring shall be substantially installed with firm connections and spark plug and all other terminals shall be suitably insulated, to prevent sparking in event of contact with conductive materials. The ignition switch shall be of the enclosed type.

13:20-8.39 Auxiliary electric generators and motors

(a) Electrical equipment installed or carried upon a tank vehicle transporting Class I and Class II flammable liquids, for the operation of pumps or other devices used for the handling of product and operating product handling accessories shall meet the following requirements:

1. Generators which are mounted on the engine providing propulsive power for the vehicle or an auxiliary engine, or located in the immediate vicinity of such engine or its exhaust system, may have general purpose enclosure. Generators located elsewhere shall be provided with explosion-proof enclosure.

2. Motors having sparking contacts shall be provided with explosion-proof enclosures.

3. Wiring shall be adequate for maximum loads to be carried, and shall be installed so as to be protected from physical damage and contact with possible product spill either by location or by being enclosed in metal conduit or other oil-resistant protective covering. Junction boxes shall be sealed.

4. Switches, overload protection devices and other sparking equipment shall be located and enclosed as provided for generators in paragraph 1 of this subsection.

5. Where the generator or motor is located within an enclosed space adequate provision shall be made for air circulation to prevent possible overheating and possible accumulation of explosive vapor.

(b) Burner and burner tubes for asphalt tank vehicles shall be properly installed and maintained.

(c) The bottom of internal burner tubes shall be located as low in the tank as proper design and functioning will permit.

(d) Instructions for the proper method of operating the burner equipment and the pumping equipment, if so equipped, shall be provided. These instructions shall accompany the vehicle at all times.

(e) A legible red warning sign shall be permanently attached near the burners of any tank vehicle equipped with burners and shall contain at least the following information:

“WARNING”

This burner equipment must not be operated while the vehicle is being loaded or is in transit, or when the burner tubes are not completely submerged.

13:20-8.40 Operation of tank vehicles

(a) Drivers shall be thoroughly instructed in the proper method of operating tank vehicles.

(b) Tank vehicles shall not be operated unless they are in proper repair, devoid of accumulation of grease, oil or other flammables, and free of leaks.

(c) Dome covers shall be closed and latched while the tank vehicle is in transit.

(d) No tank vehicle shall be operated with a cargo temperature above the maximum allowable cargo temperature

specified on the warning sign required by Section 8.14(b) (Basic design) of this Chapter.

(e) No material shall be loaded into or transported in a tank vehicle at a temperature above its ignition temperature, unless properly safeguarded in a manner approved by the authority having jurisdiction.

(f) Flammable liquids with a vapor pressure of 18 psia or over at 100 degrees Fahrenheit shall be loaded only into cargo tanks constructed in accordance with Section 8.15 (Cargo tanks, piping and connections designed for flammable liquids having a vapor pressure of 18 psia or over at 100 degrees Fahrenheit) of this Chapter.

(g) Flammable liquids shall be loaded only into cargo tanks whose material used in construction shall be compatible with the chemical characteristics of the liquid. The flammable liquid being loaded shall also be compatible with the liquid hauled on the previous load unless the cargo tank has been cleaned.

Note: In case of doubt, the supplier or producer of the flammable liquid or other competent authority should be consulted.

(h) The driver, operator or attendant of any tank vehicle shall not leave the vehicle while it is being filled or discharged. Delivery hose, when attached to a tank vehicle shall be considered to be a part of the tank vehicle.

(i) Motors of tank trucks or tractors shall be shut down during making and breaking hose connections. If loading or unloading is done without the use of a power pump, the tank truck or tractor motor shall be shut down throughout such operations.

(j) The cargo tank shall be bonded to the fill-stem or some part of fill-stem piping when loading Class I or Class II flammable liquids through open domes into a cargo tank, or when loading Class III flammable liquids through open domes into a cargo tank which may contain flammable vapors from previous cargoes of Class I or Class II flammable liquids.

(k) No external bond-wire connection nor bond-wire integral with a hose are needed for the unloading of flammable liquids into underground tanks.

(l) No cargo tank or compartment thereof used for the transportation of any flammable liquid or asphalt shall be loaded liquid full. The vacant space (outage) in a cargo tank or compartment thereof used in the transportation of flammable liquids or asphalt shall be not less than one per cent; sufficient space (outage) shall be left vacant in every case to prevent leakage from or distortion of such tank or compartment by expansion of the contents due to rise in temperature in transit.

(m) Simultaneous delivery to underground tanks from two or more hoses shall be made by means of tight connections between the hose and the fill pipe.

(n) Cargo tanks shall be free of all water before they are loaded with hot asphalt.

(o) Smoking by tank vehicle drivers, helpers, repairmen, or other personnel is prohibited while they are driving, making deliveries, filling, or making any repairs to tank vehicles.

(p) Open flames shall not be used near manholes or vents.

13:20-8.41 Protection against intermixing

(a) No tank vehicles, nor any compartment thereof, which has been utilized for Class I or Class II flammable liquid, shall be loaded with Class III flammable liquid until such tank or compartment and all piping, pumps, meters and hose connected thereto have been completely drained.

(b) A tank, compartment, piping, pump, meter or hose which does not drain completely shall be flushed at the loading point with a quantity of Class III flammable liquid equal to twice the capacity of piping, pump, meter and hose, to clear any residue of Class I or Class II flammable liquid from the system.

(c) Tank vehicles transporting Class I or Class II flammable liquids in one or more compartments and Class III flammable liquid in other compartment or compartments shall be equipped with separate piping, pumps, meters and hoses for such classes of product; except that tank vehicles manufactured prior to the effective date of this standard may be continued in use without being so equipped if:

1. Lines to the common outlet or manifold are provided with interlocking selective valves which will permit only one compartment at a time to be emptied;
2. The common outlet is provided with drainage facilities and shall be drained of any Class I or Class II flammable liquid before being used for a Class III flammable liquid; and
3. The aggregate volume of the common outlet or manifold shall not exceed one gallon.

SUBCHAPTER 9. SPECIAL VEHICLE IDENTIFICATION CARD

Authority

Unless otherwise expressly noted, all provisions of this Subchapter 9 of Chapter 20 were adopted by the Director, Division of Motor Vehicles, Department of Law and Public Safety, pursuant to authority delegated at N.J.S.A. 39:4-6.

13:20-9.1 Identification card requirements

(a) Whenever a request is received for a Special Vehicle Identification Card pursuant to the provisions of N.J.S.A. 39:23, the following regulations will apply:

1. Applications will be accepted only if submitted on the form approved by the Director.
2. The Director may require the applicant to submit to a re-examination on those portions of the driver's examination which are determined to be necessary based on the applicant's physical disability.
3. The Director may require the applicant to be examined by a New Jersey registered physician appointed by the State for the purpose of determining that the applicant's stated disability qualifies him under the definition of "amputee" as it appears in N.J.S.A. 39:4-204. The cost of such examination will be absorbed by the applicant.
4. Upon receipt of an application for renewal, the Director may, in his discretion, require the applicant to submit a statement from a New Jersey registered physician recertifying qualification for the Special Vehicle Identification Card.
5. Failure to comply with the regulations as set forth in this Subchapter will result in the denial of the Special Vehicle Identification Card.

Authority

N.J.S.A. 39:2

13:20-9.2 Medical evidence by amputees

A Special Vehicle Identification Certificate may be issued to qualified amputees, as defined under N.J.S.A. 39:4-204 when such amputee has submitted medical evidence, satisfactory to the Director, on the form provided by the Director.

13:20-9.3 State driver's license or registration qualification

A Special Vehicle Identification Certificate will be issued only to qualified applicants who hold a New Jersey driver license and/or a New Jersey vehicle registration except as otherwise provided in this Subchapter.

13:20-9.4 Limitation on number of certificates

Two Special Vehicle Identification Certificates may be issued to a qualified amputee if such amputee is the registered owner of two vehicles, but in no event shall the number of Special Vehicle Identification Certificates issued to any one person exceed two.

13:20-9.5 Passenger vehicles

Special Vehicle Identification Certificates shall be issued for use on passenger vehicles only and in no event shall a certificate be issued for or used on a vehicle which is used for commercial purposes.

13:20-9.6 Temporary certificates

A Special Vehicle Identification Certificate may be issued on a temporary basis for a specified period when, in the opinion of the Director, a person is temporarily disabled to a degree which would qualify him under the provisions of N.J.S.A. 39:4-204.

13:20-9.7 Immediate family members

A Special Vehicle Identification Certificate may be issued to the registered owner of the motor vehicle when it is determined that a member of the immediate family of the registered owner is disabled to a degree which would qualify him under the provisions of N.J.S.A. 39:4-204 and that such person cannot qualify for a Special Vehicle Identification Certificate in his name only by virtue of the fact that he is not a licensed motor vehicle operator or the owner of a registered vehicle.

SUBCHAPTER 10. AUTOMATIC VEHICLE IDENTIFICATION SYSTEMS

Authority

N.J.S.A. 39:2-3, 39:3-43 and 39:3-74.

Source and Effective Date

R.1990 d.491, effective October 1, 1990.
See: 22 N.J.R. 2133(a), 22 N.J.R. 3151(b).

Subchapter Historical Note

Amended by R.1978 d.381, effective October 26, 1978.
See: 10 N.J.R. 403(b), 10 N.J.R. 557(b).

13:20-10.1 Definitions

The following words and terms, when used in this subchapter, shall have the following meanings unless the context clearly indicates otherwise.

“Automatic vehicle identification system” means a toll collection or traffic management system comprised of an interrogation/receiver unit and a remote transponder affixed to a vehicle, motor vehicle or motor-drawn vehicle.

“Motor-drawn vehicle” includes trailers, semitrailers, or any other type of vehicle drawn by a motor-driven vehicle.

“Motor vehicle” includes all vehicles propelled otherwise than by muscular power, excepting such vehicles as run only upon rails or tracks and motorized bicycles.

“Person” includes natural persons, firms, copartnerships, associations, and corporations, including a toll authority or agency organized under the laws of this State or any other state.

“Transponder” means a receiver/transmitter which automatically receives radio or light signals from an interrogation/receiver and emits a reply pulse to the interrogation/receiver.

“Vehicle” means every device in, upon or by which a person or property is or may be transported upon a highway, excepting devices moved by human power or used exclusively upon stationary rails or tracks or motorized bicycles.

Amended by R.1991 d.249, effective May 6, 1991.

See: 23 N.J.R. 21(a), 23 N.J.R. 1417(a).

Added “or traffic management” to the definition of “Automatic vehicle identification system.” Changed “System” to “Systems” in heading.

13:20-10.2 Application

(a) A person may apply to the Director to obtain approval of an automatic vehicle identification system for use on a vehicle, motor vehicle or motor-drawn vehicle registered in this State. The person shall provide the Director with sufficient information regarding the size, dimensions, composition, operation and proposed use of the automatic vehicle identification system as the Director may require, to enable the Director to determine whether the device is safe for use on a vehicle, motor vehicle or motor-drawn vehicle registered in this State. The Director may require the applicant to provide test results from an independent laboratory.

(b) The Director reserves the right to require an applicant to furnish, without charge, a reasonable number of properly identified samples for examination or to provide such demonstration as may be required.

(c) The Director reserves the right to require such additional proof as may be needed to make his determination.

13:20-10.3 Placement

(a) Each owner or operator of a motor vehicle registered in this State who participates in a testing program of an automatic vehicle identification system operated by a toll authority or agency organized under the laws of this State or any other State shall have a transponder attached to inside the motor vehicle on the left most side of the windshield as viewed from inside the motor vehicle or at such other location on the motor vehicle as the Director deems appropriate. The transponder shall not cover the inspection decal and shall be located in a position on the windshield that will not unduly restrict the vision of the driver. No more than one transponder shall be attached to the windshield of a motor vehicle pursuant to this subchapter.

(b) The placement of an automatic vehicle identification system on vehicles or motor-drawn vehicles registered in this State shall be determined by the Director based upon the size and configuration of the vehicle or motor-drawn vehicle.

(c) Nothing in this subchapter shall prohibit the placement of an automatic vehicle identification system transponder on any portion of a motor vehicle, vehicle or motor-drawn vehicle registered in this State on which its placement is not currently prohibited by either the statutory or regulatory provisions of this State.

SUBCHAPTER 11. SCHOOL BUS WARNING LAMPS

Authority

Unless otherwise expressly noted, all provisions of this subchapter were adopted by the Director, Division of Motor Vehicles, Department of Law and Public Safety, pursuant to authority delegated at N.J.S.A. 39:3-43.

13:20-11.1 General requirements

(a) School bus warning lamps shall be of the split filament type which shall at 12.8 volts draw a maximum of 6.5 amperes for both filaments.

(b) Each lamp shall be equipped with a lens not less than six inches and not more than seven inches in diameter and shall be of the hermetically sealed beam type.

(c) The exposed illuminated area of the lamps shall have no word, letter or other device intended to identify the signal except the manufacturer's marks.

(d) Lamps used for warning purposes shall be those which have been designed expressly for this purpose and shall meet the requirements of the State Board of Education.

(e) The use of lamps designed for headlamps is prohibited.

13:20-11.2 Color specifications

(a) There shall be four red and four amber lamps on each bus which shall comply with the color specifications for electric lamps as set forth in the current edition of the S.A.E. Handbook published by the Society of Automotive Engineers.

(b) The use of any additional material, in front of or behind the lens of the warning lamp for the purpose of causing the lamp to produce a red or amber light when the filaments are lighted, is prohibited.

13:20-11.3 Aiming pads

All warning lamps shall bear three aiming pads on the face of the lens and shall have the approved manufacturer's distinctive markings in a contrasting color, molded or stamped on the lens, when offered for sale for use in the State of New Jersey.

13:20-11.4 Tests

(a) The laboratory shall make the following tests of lamps in accordance with the specifications of the Society of Automotive Engineers:

1. Color test;
2. Vibration test;
3. Moisture test;
4. Dust test;
5. Corrosion test;
6. A reliability test shall be made in accordance with the recommended practice of the Society of Automotive Engineers for directional signal lamps;
7. A photometric test shall be conducted in accordance with the standards for such tests approved by the State Board of Education and the Society of Automotive Engineers and shall be of such nature as to furnish proof of compliance with the photometric minimum candle power as listed below. The Director of the Division of Motor Vehicles, in his discretion, reserves the right to alter or change the requirements for specifications or to require additional or supplementary tests at any time.

PHOTOMETRIC MINIMUM CANDLEPOWER REQUIREMENTS SCHOOL BUS WARNING LAMPS

Test Points	Degrees	Red	Amber
10 U	V	100	200
	20 L	150	300
	10 L	400	800
5 U	V	400	800
	10 R	400	800
	20 R	150	300
	20 L	200	400
	10 L	400	800
H	V	600	1200
	10 R	400	800
	20 R	200	400
	20 L	200	400
5 D	10 L	400	800
	V	600	1200
	10 R	400	800
10 D	20 R	200	400
	V	400	800

13:20-11.5 Lamp housing

The outside of the lamp housing shall be painted national school bus chrome.

13:20-11.6 Wiring

(a) All wires used in the installation of school bus warning lamps shall be of Number Ten gauge from the lamps to the door switch and Number 14 gauge wire for the remainder. All wires shall be manufactured in such a way as to be able to carry the current load without heating or any other fire danger. The wiring used must meet the specifications as set forth in the current edition of the S.A.E. Handbook published by the Society of Automotive Engineers. It should be protected in such fashion that it will be capable of withstanding severe abrasion. The wiring should be cleated at intervals so as to be properly supported. The edges of or holes in metal members into which the wire passes should be rolled or bushed with rubber grommets.

(b) Terminals shall be soldered to the ends of all wires or pressure-type terminals shall be used at the points where connections are made to switches, flashers, relays fuse blocks or circuit breakers. All other connections in the wiring system shall be soldered. Pressure-type terminals shall be of the preinsulated type and shall withstand a pull pressure of 30 pounds.

13:20-11.7 Flashers; tests

(a) Flashers used shall be capable of operating at not less than 60 flashes and not more than 120 flashes per minute under normal operating conditions. They must be located on the bus in such manner that they may be replaced readily. Flashers used to operate school bus warning lamps must be so connected that the right and left lamps will flash alternately. Each side shall be capable of carrying a minimum of 30 amperes. If thermal-type flashers are utilized, they must have magnetic relay elements.

(b) The laboratory shall make the following tests of flashers in accordance with the specifications of the Society of Automotive Engineers:

1. Vibration test;
2. Moisture test;
3. Dust test;
4. Corrosion test;
5. A reliability test shall be made in accordance with the recommended practice of the Society of Automotive Engineers for directional signal lamps for 3,000,000 cycles.

13:20-11.8 Approval

(a) No fee for approval is required

(b) The applicant for approval will be notified in a reasonable time after receipt of the laboratory report and required sample unit and after the completion of any additional tests necessary.

13:20-11.9 Verification test

(a) At any time after a device has been approved, the Director of the Division of Motor Vehicles reserves the right to require the manufacturer to submit laboratory reports on verification tests on samples selected by the Director or his representatives from manufacturers' or distributors' stock.

(b) If any such report discloses any unwarranted deviation in material, design, construction or performance, the Director may revoke the approval.

(c) Approval may be withdrawn at any time and for any cause deemed reasonable by the Director of the Division of Motor Vehicles.

13:20-11.10 Installation

(a) A 30-ampere circuit breaker or fuse shall be installed between the source of power and the master switch.

(b) The amber warning lamps shall be actuated by means of a momentary foot operated floor starter switch capable of a 60-ampere load. The switch shall be located in front of the clutch pedal on the floor board. Opening the entrance door shall automatically cut off the amber lamps and turn on the red lamps. Closing the entrance door shall automatically cut off the red lamps, and recycle the system for the next stop.

(c) A pilot light system shall be installed in a location where its operation shall be plainly visible to the driver. The pilot light system shall be on when the warning lamps are all functioning properly and shall go off when one or more warning lamps shall fail to operate.

(d) A 20-ampere master switch shall be provided so that the warning lights can be disconnected when the bus is to be stopped for reasons other than receiving or discharging of pupils.

(e) All door switches shall have silver contacts and shall have a minimum of $\frac{1}{8}$ -inch overtravel when the plunger is in a depressed position. Switches shall be capable of carrying a minimum load of 20 amperes.

(f) Manual-controlled switches for the operation of school bus lamps will not be permitted.

(g) Door switches shall be mounted on a bracket which shall be structurally equal to a minimum thickness of 11-gauge cold-rolled steel. The bracket shall be mounted securely to prevent switch movement.

(h) All relays shall be mounted in an enclosure and operate from the vehicular power system. Relays shall utilize a D.C. coil and all contacts shall be capable of continuously carrying 20 amperes at 12.8 volts without significant pitting, erosion or tendency toward contact welding. Relays, when mounted vertically, shall withstand 10G's force

in a vertical plane and contacts shall not open when energized. Relays shall withstand 5G's force in a vertical plane and not make contact when the coil is deenergized. All connections on the relay shall be screw type.

13:20-11.11 Start-up tests; repairs

The operator of the bus must test the warning lamps before the start of each trip. The test shall be made by closing the master switch actuating the foot control switch and opening the bus door. The driver shall then observe the operation of the pilot light system and the operation of the front and rear warning lamps. Should the lamps fail to operate, then repairs must be made or replacement parts installed before the start of the trip.

13:20-11.12 Approved lamps, switches and relays

A list of approved lamps, flashers, switches and relays may be secured by writing to the Division of Motor Vehicles, Bureau of Vehicle Inspection, 25 South Montgomery Street, Trenton, New Jersey, 08608.

13:20-11.13 Compliance

Any school bus may be equipped with warning lights, as prescribed in this subchapter, on or after October 1, 1961; provided, however, that all school buses registered and operating in New Jersey must comply with the provisions of this subchapter on or before September 1, 1962.

SUBCHAPTER 12. ACCIDENT PREVENTION CLINIC

Authority

N.J.S.A. 39:2-3, 39:3-10, 39:3-11 and 39:5-30.

Source and Effective Date

R.1984 d.492, effective October 16, 1984.
See: 16 N.J.R. 2347(a), 16 N.J.R. 3054(b).

Subchapter Historical Note

This subchapter was filed and became effective for readoption on October 16, 1984 as R.1984 d.492. See: 16 N.J.R. 2347(a), 16 N.J.R. 3054(b). See chapter and section levels for further amendments.

13:20-12.1 Definitions

The following words and terms, when used in this subchapter, shall have the following meanings unless the context clearly indicates otherwise.

“Moving traffic violation” means a violation of the provisions of N.J.S.A. 39 where actual operation and movement of a vehicle is an element of the statutory violation.

“Traffic accident” means an accident which is required to be reported under the provisions of N.J.S.A. 39:4-130.

13:20-12.2 Reexamination; categories

(a) The Director may require persons who operate motor vehicles on the highways of this State to be reexamined to determine their ability to operate motor vehicles safely. Reexamination may be required of persons in the following categories:

1. Persons having mental or physical disorders which may affect their ability to safely operate a motor vehicle.
2. Persons involved in a traffic accident resulting in a fatality where a violation of any of the provisions of N.J.S.A. 39:4-1 et seq. is established;
3. Persons who have accumulated 12 or more points as provided in N.J.A.C. 13:19-10.1;
4. Persons convicted of violating any of the provisions of N.J.S.A. 39:4-1 et seq. where it appears the offense was of such a careless, reckless or indifferent nature as to require reexamination.

As amended, R.1979 d.435, eff. October 31, 1979.
See: 11 N.J.R. 349(a), 11 N.J.R. 628(c).

13:20-12.3 Vision examination

The Director may require a vision examination, by a New Jersey licensed doctor of medicine or optometrist, of persons involved in one traffic accident who have not had a vision check by Division personnel within the ten-year period immediately preceding the date of the accident.

SUBCHAPTER 13. (RESERVED)

As amended, R.1972 d.107, effective July 1, 1972.
See: 4 N.J.R. 105(a), 4 N.J.R. 165(c).

SUBCHAPTER 14. PARKING ON STATE PROPERTY

Authority

Unless otherwise expressly noted, all provisions of this Subchapter 14 of Chapter 20 were adopted by the Director, Division of Motor Vehicles, Department of Law and Public Safety, pursuant to authority delegated at N.J.S.A. 39:4-208.

13:20-14.1 Vehicle registration and parking permit

Except as hereinafter provided, the operator of any motor vehicle shall not park, store or drive said vehicle on any parking area, building or grounds, under the jurisdiction of the Division of Motor Vehicles unless said vehicle is properly registered with the Division of Motor Vehicles and a parking permit is issued for same.

13:20-14.2 Application

Application for the registration and the issuance of a parking permit shall be made to the person or officer having jurisdiction in such matters (Chief Personnel Officer).

13:20-14.3 Affixing permit

Upon approval a permit will be issued for the vehicle for which the application is made, and said permit is to be affixed to the right rear window of said vehicle in the lower corner.

13:20-14.4 Infringement on reserved spaces

These rules shall require that spaces that are reserved for any person, or agency, shall be recognized as such, and that there be no infringement of reservation privileges.

13:20-14.5 Duration of parking privilege

The privilege of parking will remain in effect so long as the person to whom the permit is issued abides by all of the rules of safe driving, and the rules prescribed by the issuing authority, and does not encroach upon the rights of others.

13:20-14.6 Suspension

The privilege herein granted shall be suspended during any State or national emergency.

13:20-14.7 Penalty

Any person or persons violating these regulations shall be subject to the penalties prescribed by N.J.S.A. 39:4-209.

carbide core bonded to an outer casing or shell of plastic, aluminum or steel.

“Stud tire” means an automobile tire fitted with studs in the tread in openings moulded for that purpose by the tire or tread manufacturer.

13:20-15.2 Federal requirements

(a) The manufacturer shall prepare precise specifications covering the number, pattern of installation and type of stud to be used in each type of tire for which approval is applied.

(b) When installed there shall be a minimum of 1/8 inch of rubber between the base of the stud and the body of the tire.

(c) When installed the tip of the stud shall project not more than .060 inch from the surface of the tire.

(d) In the interest of highway maintenance, approval for stud tires will not be granted for tires operating with recommended air pressure greater than 36 p.s.i.

(e) Studs when inserted shall be firmly and squarely seated in the tire.

(f) The manufacturer shall be responsible for proper installation of studs whether such installation is done as a factory operation or by a dealer or jobber licensed by the manufacturer.

(g) No stud tire shall be used on a public highway earlier than November 15, or later than April 1, of any winter season.

As amended, R.1971 d.180, effective October 15, 1971.
See: 3 N.J.R. 180(c), 3 N.J.R. 227(b).

SUBCHAPTER 15. STUD TIRES

Authority

Unless otherwise expressly noted, all provisions of this Subchapter 15 of Chapter 20 were adopted by the Director, Division of Motor Vehicles, Department of Law and Public Safety, pursuant to authority delegated at N.J.S.A. 39:3-43 and 39:3-81.

13:20-15.1 Definitions

The following words and terms, as used in this Subchapter, shall have the following meanings unless the context clearly indicates otherwise.

“Body of a tire” means the fabric or cord material to which the rubber tread material is bonded.

“Manufacturer” means the person or corporation who makes or fabricates the tire or tread.

“Psi” means pressure in pounds per square inch.

“Stud” means a pin type device prepared for installation in the tread of an automobile and consists of a tungsten

13:20-15.3 Application for product approval

(a) A manufacturer of a stud tire seeking approval of his product for legal sale and/or use in New Jersey shall apply therefore by letter addressed to the Director stating that his product meets the “Requirements for Product Approval”.

(b) The Director reserves the right to require additional proof of product conformity with such requirements.

13:20-15.4 Provisional certificate

(a) A provisional certificate of approval may be issued by the Director provided that:

1. The manufacturer applies therefor, certifying that his product conforms with the requirements of this Subchapter.

2. Three matched pairs of sample tires of the type for which approval is requested are submitted to the Director in such size or sizes as he may designate. The Director reserves the right to deny a certificate of approval for any

type of stud tire he has reason to believe does not conform with requirements herein.

SUBCHAPTER 16. CONCRETE READY-MIX TRANSIT VEHICLES

Authority

N.J.S.A. 39:3-63

13:20-16.1 Lighting exceptions

Concrete ready-mix transit vehicles are hereby excluded from complying with the requirements contained in N.J.S.A. 39:3-61 pertaining to rear identification lamps and rear clearance lamps.

SUBCHAPTER 17. DRIVER IMPROVEMENT SCHOOLS

13:20-17.1 Purpose

(a) The Director of the Division of Motor Vehicles of the Department of Law and Public Safety recognizing his responsibility to control the driving of persons to whom he issues driver licenses and further recognizing his responsibility in the field of highway safety, hereby promulgates this regulation establishing Division Driver Improvement Schools.

(b) The purpose of the Division Driver Improvement Schools is to correct the attitude, driving habits and disregard of the motor vehicle laws of drivers who, in the opinion of the Director and according to the records of the Division, have established unfavorable driving records.

13:20-17.2 Attendance

The Director, in his discretion, may require attendance and successful completion of a Driver Improvement School Course as a condition to restoration of a driver license privilege, or he may permit attendance in lieu of all or part of a period of suspension.

13:20-17.3 Amount of fee

Any person attending a Division of Motor Vehicles driver improvement school shall pay an attendance fee of \$100.00.

R.1972 d.155, eff. August 7, 1972.

See: 4 N.J.R. 165(a), 4 N.J.R. 223(c).

R.1982 d.485, eff. January 17, 1983.

See: 14 N.J.R. 1154(b), 15 N.J.R. 93(b).

Increased fee from \$20.00 to \$40.00.

Amended by R.1995 d.365, effective July 3, 1995.

See: 27 N.J.R. 1521(b), 27 N.J.R. 2592(b).

Increased the fee from \$40.00 to \$100.00.

13:20-17.4 Manner of payment

(a) Payment of the prescribed attendance fee shall be made only by check or money order. Such check or money order shall accompany the request for an opportunity to attend driver improvement school.

(b) Both request and payment must be sent to the Driver Improvement Bureau, Division of Motor Vehicles, 25 South Montgomery Street, Trenton, New Jersey 08608 within ten days from the date of the notice of proposed suspension.

(c) No one shall be scheduled to attend driver improvement school until the full attendance fee for that person has been received by the Division of Motor Vehicles.

R.1972 d.155, eff. August 7, 1972.

See: 4 N.J.R. 165(a), 4 N.J.R. 223(c).

13:20-17.5 Penalty

Failure to make payment in the amount and manner prescribed in these provisions shall automatically result in the imposition of the suspension for the period originally set forth in the notice of proposed suspension.

R.1972 d.155, eff. August 7, 1972.

See: 4 N.J.R. 165(a), 4 N.J.R. 223(c).

SUBCHAPTER 18. FLASHING WARNING SIGNALS

Authority

Unless otherwise expressly noted, all provisions of this Subchapter 18 of Chapter 20 were adopted by the Director, Division of Motor Vehicles, Department of Law and Public Safety, pursuant to authority delegated at N.J.S.A. 39:4-43.

13:20-18.1 Switching approval

(a) On and after January 2, 1965, every switching arrangement permitted by N.J.S.A. 39:3-54 or required by N.J.S.A. 39:3-64 for flashing vehicular traffic hazard warning signals shall be of a type approved by the Director of the Division of Motor Vehicles.

(b) The sale of any unapproved equipment is prohibited under N.J.S.A. 39:3-77.

13:20-18.2 Vehicular hazard warning signal defined

A vehicular hazard warning signal operating unit is a driver-controlled device which causes all turn signal lamps to flash simultaneously to indicate to the approaching drivers the presence of a vehicular hazard and causes required pilot indicators to flash.

13:20-18.3 Electrical components

The assembly of electrical components that constitute a hazard warning device are a switch, a flasher, a pilot (indicator) lamp and a fuse (or circuit breaker) wired for ready installation in the turn signaling system of a motor vehicle.

13:20-18.4 Independent or combination unit

The unit may be either an independent switch or in combination with the turn signal operating unit.

13:20-18.5 Operation independent of ignition

The vehicular hazard warning signal function shall operate independently of the ignition switch.

13:20-18.6 Operating motion

If the hazard warning operating unit is combined with the turn signal operating unit, the operating motion of the hazard function shall differ from the actuating motion of the turn signal function.

13:20-18.7 Actuation of switches

If the vehicular hazard warning unit requires the operation of more than one switch, a means shall be provided for actuating all switches simultaneously by a single driver action.

13:20-18.8 Wiring

The unit must be wired with not less than 18-gauge stranded copper wire, properly insulated, except that lighter gauge wiring may be used for the pilot (indicator) lamp.

13:20-18.9 Contact points

The switch shall have contact points made of copper, brass or similar acceptable material.

13:20-18.10 Printed circuit

The device may be on a printed circuit when factory installed as original equipment on a motor vehicle.

13:20-18.11 Pilot indicators

(a) In vehicles equipped with right and left-turn signal pilot indicators, both pilots and/or a separate pilot shall flash simultaneously while the vehicular hazard warning operating unit is turned "on".

(b) In vehicles equipped with a single turn signal pilot (indicator), a separate hazard warning pilot (indicator) shall flash and turn signal pilot may flash while the hazard warning operating unit is turned "on".

(c) If a separate hazard warning pilot is used, it shall emit a red color and have a minimum projected area equivalent to a ½-inch diameter circle.

13:20-18.12 Flashers

(a) Flashers used with vehicular hazard warning switches shall be capable of flashing the specified lamp load between 60-120 FPM and 30 to 75 percent "on" time.

(b) In the event of a failure of one or more of the hazard signal lamps, the remaining lamps shall continue to flash.

13:20-18.13 Fuse

The fuse (or circuit breaker) must be adequate to carry the current required for flashing the required number of lamps, with a reasonable allowance for overload.

13:20-18.14 Application for product approval

A manufacturer, assembler or vendor of a hazard warning device seeking approval of his product for legal sale and/or use in New Jersey shall apply therefor by letter addressed to the Director stating that his product meets the requirements for product approval in Sections 18.17 through 18.20 of this Chapter and he shall submit to the Director a report of an independent testing laboratory certifying that the product has been tested and found to conform with the laboratory testing requirements in Section 18.21 of this Chapter. The Director reserves the right to require additional proof of product conformity with such requirements.

13:20-18.15 Temporary certificate

(a) A temporary six-month certificate of approval may be issued by the Director; provided that:

1. The manufacturer applies therefor certifying that his product conforms with the requirements of this Subchapter.
2. Laboratory test reports are pending and will be submitted to the Director promptly when received.
3. Two samples of the hazard warning device are submitted to the Director together with the package, instructions and other literature as the device will be marketed, if approved.

(b) The Director reserves the right to deny a temporary certificate of approval for any device he has reason to believe does not conform with requirements of this Subchapter.

13:20-18.16 Approval

No hazard warning device may be offered for sale, sold, installed or used on a motor vehicle on and after January 2, 1965, unless it has been officially approved by the Director and a certificate of approval therefor has been issued to the applicant.

13:20-18.17 Identification

(a) Every hazard warning or combination switch must be provided with marks or identification as follows:

1. The housing must be permanently and legibly marked with the manufacturer's name, or trade name, and model or type designation.

2. These markings must be visible after installation except on devices approved and installed as original equipment when the vehicle is assembled.

13:20–18.18 Installation instructions

(a) Complete installation instructions must be included with all hazard warning devices which are not part of the original equipment of a vehicle, outlining the proper method for installing the unit for all possible wiring combinations.

(b) The wiring instructions shall clearly indicate voltage and properly identify the flasher to be used.

13:20–18.19 Operating instructions

(a) Operating instructions shall be included in both original and after-market equipment.

(b) A warning shall be included which prohibits the use of the hazard warning device in any manner not in compliance with the law.

13:20–18.20 Samples for inspection and testing

(a) The manufacturer, assembler or vendor shall submit three complete hazard warning devices, together with installation instructions, to an independent testing laboratory for testing in accordance with the requirements set forth in Section 18.21 (Laboratory testing requirements) of this Chapter.

(b) Two duplicates of the hazard warning device submitted to the laboratory for testing shall be sent to the Director for official approval, together with the package, instructions and any other literature as the device will be marketed when approved. Accompanying this submittal must be a certified copy of the laboratory report on the same device.

(c) If changes are made in the construction or material of an approved hazard warning device, the Director shall be notified immediately and given the reason for the change. Approval of the change shall be obtained prior to offering the modified device for sale.

(d) Samples submitted to laboratory for testing shall be representative of the product as manufactured and as it will be marketed, if approved.

13:20–18.21 Laboratory testing requirements

(a) The applicant for approval of a hazard warning device shall have an independent testing laboratory test its product and certify its conformity with the requirements set forth in this Subchapter.

(b) For the test, the applicant will provide the laboratory with three hazard warning devices of the type on which approval will be requested and ten extra flashers, which shall be duplicates of the flashers in the three devices.

(c) The applicant will state the total number of 32-candlepower bulbs in a 12-volt system or 21-candlepower bulbs in a six-volt system, plus pilot lamp bulbs, that his device is designed to flash simultaneously and continually at the required flashing rate of not less than 60 nor more than 120 flashes per minute, and the laboratory tests shall determine the propriety of such claim.

(d) On the basis of its testing, the laboratory will certify conformity or nonconformity of the device and its components with the following requirements:

1. The device must be so designed that when it is installed in the turn signaling system of a motor vehicle and is turned on, it will cause all turn signal lamps on both sides of the front and rear of the vehicle (or combination of vehicles) to flash simultaneously and continue such flashing until the electricity is turned off.

2. The ten duplicate flashers shall be tested for prolonged usage. Circuitry and equipment for the tests shall conform with SAE standard "Automotive Flasher Test Equipment—SAE J823". Voltage drop test shall conform with SAE Standard "Automotive Flashers—SAE J590a".

3. The vehicular hazard warning signal operating unit shall be tested at rated voltage with the maximum bulb load as specified by the manufacturer. (Note: The flasher not to be included in the circuit during test.) The unit shall be turned on and off in the normal manner, at a rate of not more than 15 CPM. One cycle shall consist of "off" to "on" and returned to "off". The test sequence shall consist of:

i. 9,000 cycles at a temperature of 75 degrees Fahrenheit plus or minus ten degrees Fahrenheit;

ii. 500 cycles at a temperature of 150 degrees Fahrenheit plus or minus five degrees Fahrenheit;

iii. 500 cycles at a temperature of minus 20 degrees Fahrenheit plus or minus five degrees Fahrenheit;

iv. One hour "on" at a temperature of 75 degrees Fahrenheit plus or minus ten degrees Fahrenheit.

4. The unit shall be operative at the completion of the test (except bulbs may be replaced during the period of test) and the voltage drop from input terminal to each output terminal (including three inches of Number 16 or 18 gauge wire on each side of the switch) shall not exceed 0.3 volts for either 6.4 or 12.8 line voltage before and after the life test. A combination switch shall meet all other applicable requirements for its function, in addition to the above life test.

5. The following sections in the SAE Standard "Tests for Motor Vehicle Lighting Devices and Components—SAE J575a" are a part of these requirements:

Section "B"—Samples for tests

Section "C"—Bulbs

Section "D"—Laboratory Facilities

6. Combination switches that have not already been tested and approved as turn signaling devices must be tested as hazard warning devices under this regulation and as turn signaling devices under SAE Standard "Turn Signal Operating Units—SAE J589".

(e) The laboratory report:

1. Shall state results of testing of hazard warning flashers and switches submitted to it for testing.

2. Shall contain a complete description of the device and its components submitted to it for testing, and complete identification markings used on the device and its components. (Package names and number will not be acceptable.)

3. Shall report nonconformity as well as conformity and state reasons, if known, for nonconformity.

13:20-18.22 Verification

(a) As a safeguard against deviation of design, construction, or material from that on which the original approval was based, the Director reserves the right to require the manufacturer to submit a hazard warning device being sold or manufactured under the approval granted, or to select samples from distributor's or manufacturer's stock.

(b) A test of such samples resulting in any type failure will be sufficient cause for withdrawal of approval.

(c) The Director also reserves the right to require additional tests of an approved hazard warning device whenever it is deemed necessary.

SUBCHAPTER 19. SEAT BELTS

Authority

Unless otherwise expressly noted, all provisions of this Subchapter 19 of Chapter 20 were adopted by the Director, Division of Motor Vehicles, Department of Law and Public Safety, Pursuant to authority delegated at N.J.S.A. 39:3-43.

13:20-19.1 General requirements

(a) The manufacturer shall prepare precise specifications covering the installation of his seat belts and anchorages and shall include directions for installation in each belt package.

(b) Specifications for belts and anchorages shall be in conformance with the recommended practices of the Society of Automotive Engineers as published in the most recent annual edition of the S.A.E. Handbook.

13:20-19.2 Application for product approval

(a) A manufacturer of seat belts and anchorages seeking approval of his product for legal sale and/or use in New Jersey shall apply by letter therefor addressed to the Director.

(b) He shall submit a laboratory report from a recognized commercial testing laboratory or the National Bureau of Standards which shall indicate the results of tests conducted in accordance with the S.A.E. recommended practices.

(c) He shall submit to the Director two samples, which cannot be returned, of his product packaged as it will be marketed.

13:20-19.3 Certificate of approval

(a) The Director may issue a certificate of approval after examination of the product and the laboratory reports.

(b) The right is reserved to revoke a certificate of approval on a product where continued adherence to standards in manufacturing is not maintained.

SUBCHAPTER 20. NEW TIRES

Authority

Unless otherwise expressly noted, all provisions of this Subchapter 20 of Chapter 20 were adopted by the Director, Division of Motor Vehicles, Department of Law and Public Safety, pursuant to authority delegated at N.J.S.A. 39:3-43.

13:20-20.1 Adoption of Vehicle Equipment Safety Commission regulation

The attached Regulation V-1, as set forth in Section 20.7 through 20.30 of this Chapter, adopted May 14, 1965, and revised October 11, 1965, by the Vehicle Equipment Safety Commission is hereby adopted for the State of New Jersey effective July 1, 1966.

13:20-20.2 Approval

(a) No person shall have for sale, sell or offer for sale, or use any new tire designed for use on passenger cars and station wagons and manufactured after July 1, 1966, unless such tire is of a type approved by the Director of the Division of Motor Vehicles.

(b) Regardless of the date of its manufacture, no new tire designed for use on passenger vehicles and station wagons may be offered for sale or sold on and after July 1, 1967, unless it has been officially approved by the Director.

13:20-20.3 Requirements for product approval

(a) Every tire required to be approved shall be tested in accordance with the uniform test procedures prescribed by Regulation V-1 of the Vehicle Equipment Safety Commission and shall meet the minimum performance requirements set forth therein.

(b) Required tests shall be made by a recognized independent testing laboratory or by the National Bureau of Standards.

(c) Test reports submitted to the Director for the purpose of securing approval of a tire must indicate the results of tests made. Such reports must contain a certification as to the accuracy of the report and that the tires tested comply with the requirements of this Subchapter.

13:20-20.4 Procedure for securing approval

(a) A manufacturer or vendor of tires seeking approval of his product for legal sale and/or use in New Jersey shall apply by letter therefor addressed to the Director.

(b) He shall submit to the Director a test report certified as required in Section 20.3(c) of this Chapter.

(c) The Director reserves the right to require the manufacturer to furnish without charge a reasonable number of samples of his product for examination.

13:20-20.5 Certificate of approval

The Director may issue a certificate of approval upon receipt of the tire manufacturer's application for approval of his product and accompanying test report specified in Section 20.4(b) of this Chapter.

13:20-20.6 Revocation of approval

The right is reserved to revoke a certificate of approval on a product where continued adherence to standards in manufacturing is not maintained.

13:20-20.7 Scope

This specification is for new pneumatic tires, designed for use on passenger cars and station wagons operated on highways open to public use for vehicular traffic.

13:20-20.8 Definitions

The following words and terms when used in this Subchapter, shall have the following meanings, unless the context clearly indicates otherwise.

“Bead” means that part of the tire which is shaped to fit the rim.

“Carcass” means tire structure, excepting tread and sidewall rubber.

“Chunking” means separation of the tread from the carcass in particles which may range from a very small size to several square inches in area.

“Cord” means strands forming a ply in a tire.

“Cross section” means the lateral width of a tire mounted on an official measuring rim, after it has been allowed to stand for 24 hours at room temperature inflated to the pressure recommended in Table 1, set forth in Section 20 of this Chapter. An official measuring rim is one that has been calibrated and found to meet the precise measurements specified by the Tire and Rim Association, Inc. The tire shall be calipered at six different points approximately equally spaced around the circumference. The average of these measurements is to be taken as the cross section. In the event the widest part of the tire occurs at a letter of sidewall design, the height of such configuration shall be deducted from measurements. The tire shall meet the minimum cross section dimensions specified in Table 1, set forth in Section 20.26 of this Chapter, for the tire size listed.

“Groove” means space between two tread rows.

“Ply” means layer of parallel cords used in forming the tire body.

“Ply rating” means an index of tire strength which does not necessarily represent the actual number of plies in the tire.

“Rib” means tread section running circumferentially around tire.

“Rim” means metal support for tire or tire and tube assembly on the wheel. Tire beads are seated on the rim.

“Sidewall” means the portion of tire between buttress and bead.

“Standard rim” means one that has been calibrated and found to meet the precise measurements specified by the Tire and Rim Association, Inc.

“Tread” means the portion of tires which comes in contact with road.

“Tread separation” means tread pulling away from tire body.

13:20-20.9 Preparation of tire for endurance test

(a) A new tire shall be mounted on a standard rim and inflated to the pressure shown in Table 1 set forth in Section 20.26 of this Chapter.

(b) Loads on the tire during the test shall be determined with the tire positioned on the standard test wheel after the tire has been conditioned at a temperature of 100 degrees Fahrenheit plus or minus five degrees Fahrenheit, for a minimum of three hours and with inflation pressure adjusted to that specified.

(c) Four groups of cuts shall be placed circumferentially around the tire, spaced approximately 90 degrees apart. Each group shall consist of one cut in each groove with the cuts located so that one does not come directly opposite a cut in the adjacent groove. Dimension of cuts are to be 1/4-inch long and 1/16-inch deep. If brambles or tie bars are present in the grooves, the cuts shall be located approximately midway between them.

(d) The initial total length of the cuts so made shall be recorded for the particular tire involved.

13:20-20.10 Equipment

(a) The test wheel shall be a flat-faced steel wheel 67.23 inches in diameter and at least the same width as the cross-sectional diameter of the tire to be tested.

(b) The tire while being tested shall be located in an air space controlled at a temperature of 100 degrees Fahrenheit, plus or minus five degrees Fahrenheit.

13:20-20.11 Procedure

(a) The tire and wheel assembly shall be mounted on the test axle and pressed against the test wheel with the required axle load.

(b) Specifications for the test shall be as follows: 100 per cent of the required axle load shall be the load specified in Table 1, set forth in Section 20.26 of this Chapter.

TIRE ENDURANCE TEST

Speed	Initial Inflation Pressure	Test Load	Hours	Test Miles
50 MPH	From Table 1	100%	4	200
		120%	6	300
		140%	24	1,200
		Total		1,700

13:20-20.12 Test results

At the conclusion of the endurance test, there shall be no evidence of tread, ply, cord or bead separation or broken cords. The final total length of such cuts made pursuant to Section 20.9 (Preparation of tire for endurance test) of this Chapter shall not exceed five times the length of the original cuts (400 percent increase) made for this test.

13:20-20.13 Preparation of tire for breaking energy test

(a) The tire used in this test shall be one which has survived the endurance test.

(b) This tire shall be mounted on a standard rim and shall be inflated to the pressure shown in Table 1, set forth in Section 20.28 of this Chapter.

13:20-20.14 Breaking energy test equipment

The test shall be made with a cylindrical steel plunger 3/4 inches in diameter with a hemispherical end.

13:20-20.15 Procedure

(a) The plunger shall be forced into the tread as near to the center line as possible avoiding penetration into a tread groove or in the area of the cuts made pursuant to Section 20.9 (Preparation of tire for endurance test) of this Chapter and at the rate of two inches per minute until the tire breaks or until the plunger is stopped.

(b) Tires shall meet the requirements for minimum breaking strength as shown in Table 2, set forth in Section 20.27 of this Chapter. No tire shall have a strength below that of a tire of the same size and cross-section, with four-ply rating. For sizes not listed, the strength requirement shall not be less than that for the nearest smaller sizes in cross-section and the same ply rating.

(c) Final measurement of force and penetration at break shall be made at five points equally spaced around the circumference of the tire. In the event the tire does not break before the plunger is stopped by the rim, the force and penetration shall be taken as this occurs. The energy value to break a tire shall be calculated from the average value at break by means of the following formula:

$$W = \frac{F \times P}{2}$$

Where

- W = Energy at break in inch pounds
- F = Force at break in pounds
- P = Penetration at break in inches

13:20-20.16 Preparation of tire for high speed test

(a) A new tire shall be mounted on a standard rim and inflated to 30 psi pressure.

(b) The tire shall be conditioned at a temperature of 100 degrees Fahrenheit, plus or minus five degrees Fahrenheit, for a minimum of three hours and with inflation pressure adjusted to that specified.

13:20-20.17 High speed test equipment

(a) The test wheel shall be a flat-faced steel wheel 67.23 inches in diameter and at least the same width as the cross-sectional diameter of the tire to be tested.

(b) The tire while being tested shall be located in an air space controlled at a temperature of 100 degrees Fahrenheit, plus or minus five degrees Fahrenheit.

13:20-20.18 Procedure

The tire and wheel assembly shall be mounted on the test axle and press against the test wheel with the load as specified in Table 1, set forth in Section 20.26 of this Chapter. Specifications for the progressive test speeds and conditions shall be as follows:

HIGH SPEED PERFORMANCE

Speed	Initial Inflation Pressure	Test Load	Hours	Test Miles
50 MPH (1)	30 psi	From Table 1	2	100
75 MPH	30 psi	From Table 1	½	37.5
80 MPH		From Table 1	½	40
85 MPH (2)			½	42.5
		Total Miles		220.0

1. After two hours break-in, running at 50 MPH, the tire should be allowed to cool to 100 degrees Fahrenheit temperature. Inflation pressure should then be readjusted to 30 psi before continuing test.

2. This test is not performed on deep tread winter tires.

13:20-20.19 High speed test results

At the conclusion of the high speed performance tests there shall be no evidence of separation or tread chunking.

13:20-20.20 Preparation of tire-wheel assembly for bead unseating test

The tire should be washed and dried at the two beads, mounted on a new finished painted standard rim without the use of lubrication and inflated to pressures indicated in Table 1 set forth in Section 20.26 of this Chapter at ambient temperature.

13:20-20.21 Bead unseating test equipment

A fixture used to support the mounted tire-wheel assembly is shown in Figure 1 set forth in Section 20.28 of this Chapter. A standard block (detailed in Figure 2 set forth in Section 20.29 of this Chapter) is forced against the tire sidewall as dictated by the fixture geometry. This load can be applied by a hydraulic ram or its equivalent.

13:20-20.22 Bead unseating test procedure

(a) With the tire and wheel mounted in the fixture the load should be applied through the block to the tire sidewall at a rate of two inches per minute. The load at which the bead unseats shall be recorded. Raise the block and rotate the tire-wheel assembly one wheel stud hole.

(b) Repeat the test for each stud hole position, thus acquiring from four to six load figures for each tire-wheel assembly.

13:20-20.23 Resistance to bead unseating

When tested in accordance with the foregoing procedures, the applied force required to unseat the tire bead at the point of contact shall not be less than 2,500 pounds for conventional tires mounted on 13, 14 or 15 inch rims conforming to Tire and Rim Association, Inc. standards.

13:20-20.24 Identification

(a) Each tire which meets or exceeds the standards prescribed by this Subchapter shall be permanently identified in the English language on one sidewall thereof at a location which will normally not be obstructed by the rim when the tire is inflated on the rim and will normally not be removed in a retreading or recapping process, with at least the following information:

1. Manufacturer's or distributor's name or trademark;
2. Brand name, if any;
3. Size;
4. The designation "V-1" (see design type and size as shown in Figure 3 set forth in Section 20.30 of this Chapter.)

(b) On the other sidewall of the tire there shall appear at least the designation "V-1" at a location which will normally not be obstructed by the rim when the tire is inflated on the rim and will normally not be removed in a retreading or recapping process.

13:20-20.25 Report

Any report required to be made to secure approval under this Subchapter shall include full information on tests and observations made as required by this Subchapter.

13:20-20.26 Table 1

Table 1. INFLATION PRESSURES, LOADS, AND RIM FOR TIRE TESTS

Tire Size (Nominal) Inches	Ply Rating	Measuring Rim (T & RA) Inches	Load Lbs.	Tire Inflation Lbs./Sq. In.	Cross Sec. (Minimum) Inches
6.00-13	4	4J	730	24	5.70
6.50-13	4	4½J	840	24	6.25
7.00-13	4	5J	920	24	6.70
6.00-14	4	4J	800	24	5.75
6.50-14	4	4½K	890	24	6.25
7.00-14	4	5K	980	24	6.70
7.50-14	4	5½K	1090	24	7.20
8.00-14	4	6K	1180	24	7.70
8.50-14	4	6K	1270	24	7.85
9.00-14	4	6½K	1360	24	8.25
9.50-14	4	6½K	1470	24	8.55
6.00-15	4	4J	900	26	5.75
6.50-15	4	4½K	1000	26	6.25
6.70-15	4	4½K	1120	26	6.55
7.10-15	4	5K	1210	26	6.95
7.60-15	4	5½K	1320	26	7.45
8.00-15	4	6L	1400	26	7.85
8.20-15	4	6L	1420	24	8.00
8.90-15	6	6½L	1790	28	8.80
6.15-14	4	4J	730	24	5.70
6.45-14	4	4½J	840	24	6.25
6.95-14	4	5J	920	24	6.65
7.35-14	4	5J	1020	24	6.95

Tire Size (Nominal) Inches	Ply Rating	Measuring Rim (T & RA) Inches	Load Lbs.	Tire Inflation Lbs./Sq. In.	Cross Sec. (Minimum) Inches
7.75-14	4	5½JK	1120	24	7.35
8.25-14	4	6JK	1210	24	7.80
8.55-14	4	6JK	1320	24	8.10
8.85-14	4	6½JK	1390	24	8.50
6.35-15	4	4½J	800	24	5.95
6.85-15	4	5J	900	24	6.45
7.35-15	4	5½JK	1035	24	7.05
7.75-15	4	5½JK	1100	24	7.15
8.15-15	4	6JK	1180	24	7.65
8.45-15	4	6JK	1280	24	7.85
8.85-15	4	6½JK	1370	24	8.25
9.15-15	4	6½JK	1470	24	8.50
9.00-15	4	6JK	1420	24	8.00

13:20-20.28 Figure 1

Tire Size Code	Minimum Breaking Inches-Lbs.
9.00-14	1625
9.50-14	1625
6.00-15	1250
6.50-15	1250
6.70-15	1375
7.10-15	1375
7.60-15	1500
8.00-15	1625
8.20-15	1625
8.90-15	1875
6.15-14	1250
6.45-14	1250
6.95-14	1250
7.35-14	1375
7.75-14	1500
8.25-14	1625
8.55-14	1625
8.85-14	1625
6.35-15	1250
6.85-15	1250
7.35-15	1250
7.75-15	1375
8.15-15	1375
8.45-15	1500
8.85-15	1625
9.15-15	1625
9.00-15	1625

13:20-20.27 Table 2

MINIMUM BREAKING ENERGY REQUIREMENTS

Tire Size Code	Minimum Breaking Inches-Lbs.
6.00-13	1250
6.50-13	1250
7.00-13	1375
6.00-14	1250
6.50-14	1250
7.00-14	1375
7.50-14	1500
8.00-14	1625
8.50-14	1625

1. LOAD ARM TO BE PARALLEL TO TIRE AND RIM ASSEMBLY AT TIME OF ENGAGEMENT.
2. LOAD BLOCK TO CONTACT TIRE AT MAXIMUM SECTION OF TIRE.

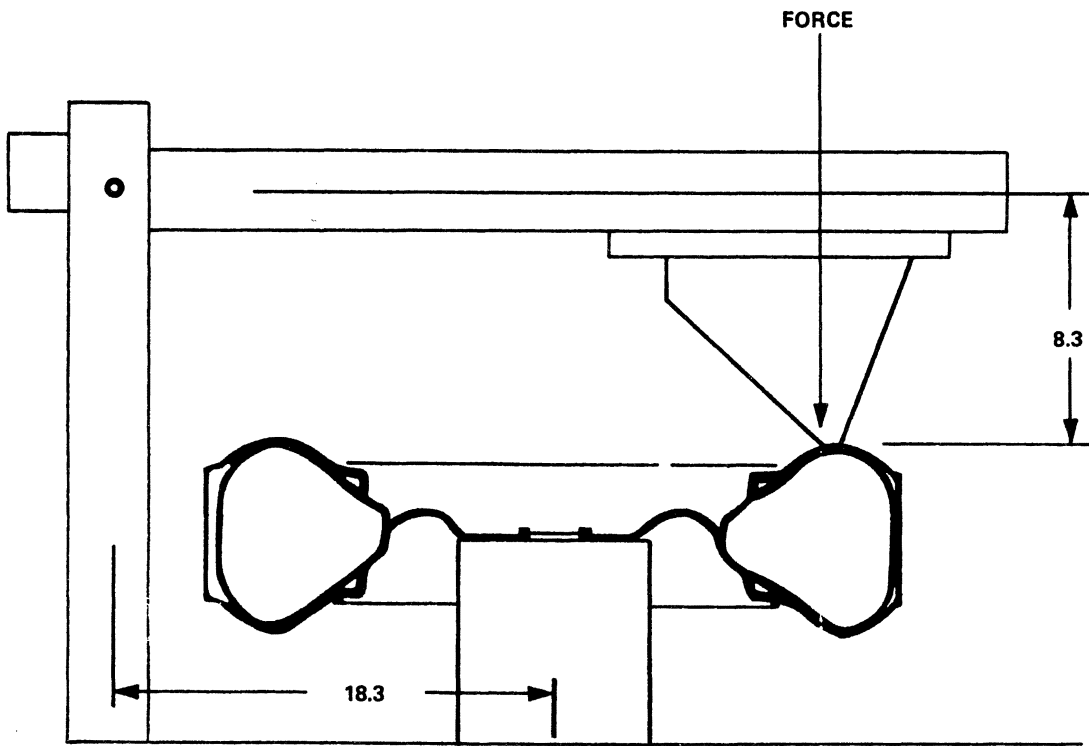

13:20-20.29 Figure 2

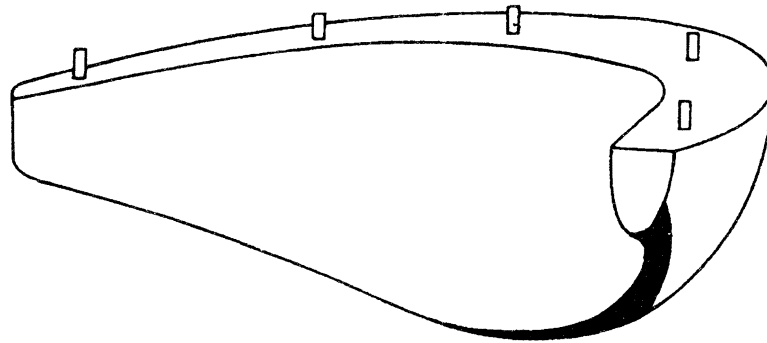
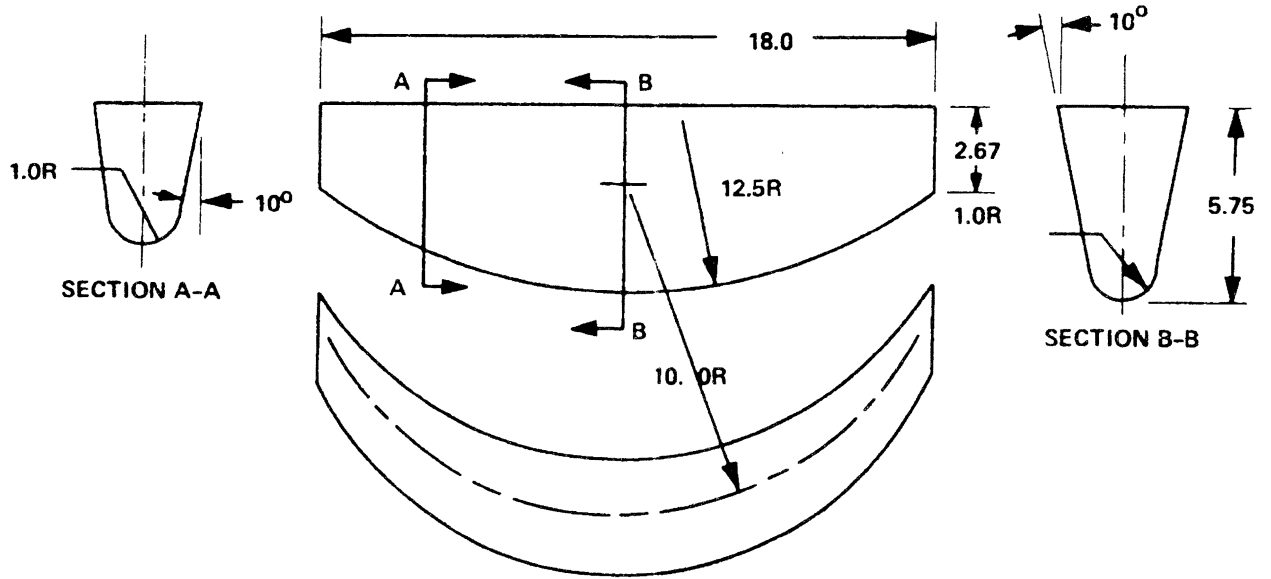

MATERIAL: HARDWOOD

13:20-20.30 Figure 3

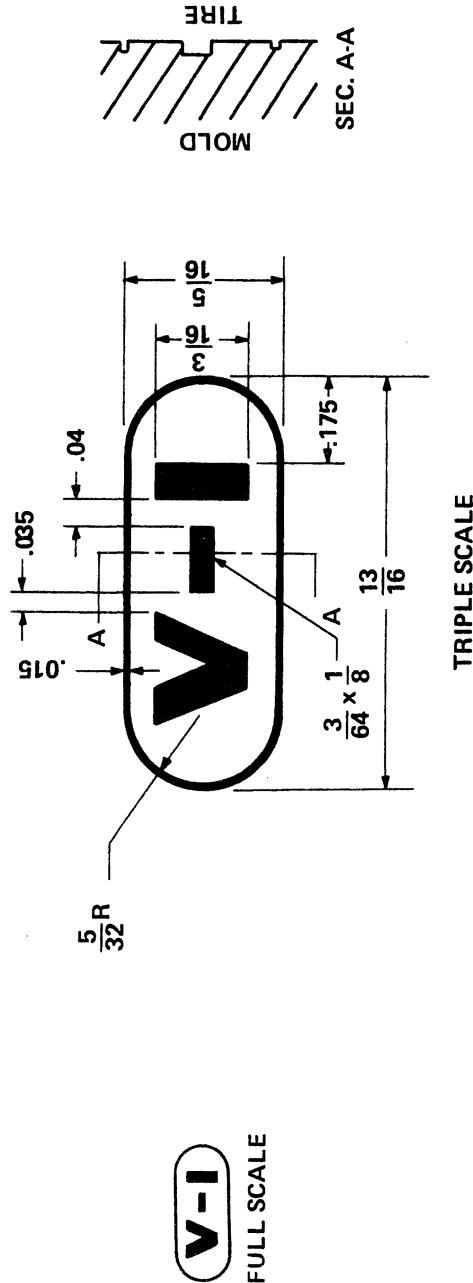

SUBCHAPTER 21. RETREAD TIRES¹

Authority

Unless otherwise expressly noted, all provisions of this Subchapter 21 of Chapter 20 were adopted by the Director, Division of Motor Vehicles, Department of Law and Public Safety, pursuant to authority delegated at N.J.S.A. 39:3-43.

13:20-21.1 Regrooved and recut tires

On and after January 1, 1968, no person shall sell, offer for sale or install on a motor vehicle any tire designed for use on passenger cars and station wagons which has been regrooved or recut unless such tire conforms to the standards and specifications of Regulation V-2 of the Vehicle Equipment Safety Commission for regrooved and recut tires.

¹ The provisions of Regulation V-2 of the Vehicle Equipment Safety Commission have been adopted for the State of New Jersey.

13:20-21.2 Approval

(a) No person shall sell, offer for sale or use any tire designed for use on passenger cars and station wagons and retreaded after January 1, 1968, unless such tire is of a type approved by the Director of the Division of Motor Vehicles.

(b) Regardless of the date of its retreading, no retreaded tire designed for use on passenger vehicles and station wagons may be offered for sale or sold on and after July 1, 1968, unless such tire is of a type which has been officially approved by the Director.

13:20-21.3 Approval procedure

(a) A retreader or distributor of tires seeking approval of his product for legal sale and/or use in New Jersey shall apply by letter therefor addressed to the Director. The application for approval shall include a facsimile of the retreader's or distributor's name or trademark as it will appear on the sidewall of the tire for which approval is sought.

(b) Applications for approval shall be accompanied by a report from a recognized independent testing laboratory and such report shall reveal that the tire for which approval is requested meets or exceeds the standards and specifications of Regulation V-2 of the Vehicle Equipment Safety Commission.

(c) The Director reserves the right to require the retreader or distributor to furnish without charge a reasonable number of properly identified samples of his product for examination.

13:20-21.4 Waiver

(a) The Director may waive the provisions of Section 21.3(b) (Approval procedure) of this Chapter pertaining to the submission of independent testing laboratory reports; provided, however, that the retreader or distributor submits in lieu thereof a statement, certified by a responsible officer of the company, that the tire for which approval is required meets or exceeds the standards of Regulation V-2.

(b) Where a certification as outlined above has been accepted in lieu of a laboratory report, the Director may, at any time it is deemed necessary to assure that the standards are being met, require that a reasonable number of tires, selected at random from the retreader's stock be tested by an independent laboratory. The cost of such tests shall be borne by the retreader.

13:20-21.5 Notice of approval

When the Director determines that the conditions of approval have been met, a notice of approval will be issued.

13:20-21.6 Withdrawal of approval

The right is reserved to withdraw approval of a product at any time and for any cause deemed reasonable by the

Director, or the Director may require new approvals at any time it is deemed necessary or reasonable.

SUBCHAPTER 22. BRAKE LININGS**Authority**

Unless otherwise expressly noted, all provisions of this Subchapter 22 of Chapter 20 were adopted by the Director, Division of Motor Vehicles, Department of Law and Public Safety, pursuant to authority delegated at N.J.S.A. 39:3-43.

13:20-22.1 Standards and specifications

Standards and specifications for the approval of brake linings shall be those established by the most recent revision of Regulation V-3 of the Vehicle Equipment Safety Commission, unless otherwise provided by regulation promulgated by the Director of the Division of Motor Vehicles.

13:20-22.2 Approval

On and after October 1, 1967, no brake lining except that used only for parking brakes shall be sold, offered for sale or installed on a motor vehicle unless such lining is of a type approved by the Director of the Division of Motor Vehicles.

13:20-22.3 Requirements for product approval

(a) Brake linings shall be tested in accordance with the uniform test procedures prescribed by Regulation V-3 of the Vehicle Equipment Safety Commission and shall meet or exceed the minimum requirements for approval and identification set forth therein.

(b) Test reports submitted to the Director for the purpose of securing approval of a brake lining formulation shall be made on the forms prescribed by Regulation V-3. Such reports must be certified as to the accuracy of the report. The required certification must be made by a recognized independent testing agency which either physically conducted the tests or observed the tests and testing equipment even though the tests were physically conducted by the manufacturer, employees of the manufacturer or other persons.

13:20-22.4 Procedure for securing approval

(a) A manufacturer or vendor of brake linings seeking approval of his product for legal sale and/or use in New Jersey shall apply by letter therefor addressed to the Director.

(b) The manufacturer or vendor shall submit to the Director a test report certified as required in Section 22.3(b) (Requirements for product approval) of this Chapter, with two properly identified samples of the brake lining for which approval is being requested.

13:20-22.5 Notice of approval

If the Director determines that the brake lining meets the requirements of these regulations after receipt of the test report and samples, a notice of approval will be issued.

13:20-22.6 Withdrawal of approval

The right is reserved to withdraw approval of a product at any time and for any cause deemed reasonable by the Director, or the Director may require new approvals at any time it is deemed necessary or reasonable.

13:20-22.7 Brake linings manufactured prior to effective date

Brake linings manufactured prior to October 1, 1967, and which were produced from a formulation which is approved, may meet the identification requirements of this Subchapter by having the necessary information affixed on the brake lining.

SUBCHAPTER 23. FASTENING LOADS ON COMMERCIAL FLAT BED VEHICLES
Authority

Unless otherwise expressly noted, all provisions of this Subchapter 23 of Chapter 20 were adopted by the Director, Division of Motor Vehicles, Department of Law and Public Safety, pursuant to authority delegated at N.J.S.A. 39:4-77.

13:20-23.1 Definitions

The following words and terms, when used in this Subchapter, shall have the following meanings unless the context otherwise clearly indicates.

“Bands (High tension)” means bands of various materials and sizes, each with a standard load strength, used to secure cargo.

“Blocks” means wooden or metal material used to secure cargo.

“Braces” means material used to retain cargo or blocking in position.

“Cable” means cargo securement equipment of definite size, composed of a number of twisted strands of a certain number of wires each.

“Cable fasteners” means metal fasteners of the swaged type, or equipped with a bolt or bolts, and used to secure cable to the vehicle bed or cargo.

“Chain” means a series of metal links or rings, connected, or fitted into one another.

“Clamping piece” means a wooden or metal member braced across top of load to keep cargo in position, and secured to vehicle.

“Cleats” means wooden or metal pieces used to reinforce blocking.

“Fastening device” means rope, chain, cable, strap, or other means, used to tie down an article to the vehicle to prevent movement or shifting.

“Flat bed vehicle” means a vehicle with a flat or platform-type floor, without permanent sides.

“Stakes” means pieces of timber or metal inserted in stake pockets on sides or ends of vehicle to hold load in place.

“Stake pockets” means metal receptacles attached to sides or ends of vehicle floor to receive ends of stakes.

“Thimbles” means metal protectors used to prevent cutting or breaking of cable at sharp turns.

“Wire (Common)” means soft wire of various sizes. (Use prohibited)

“Wire (High tension)” means steel wire of a definite size and load strength used to secure cargo.

13:20-23.2 Cargo securely fastened

Every motor vehicle or motor-drawn vehicle of the flat bed type carrying cargo, the nature of which is such that the shifting thereof would endanger persons or property, shall have such cargo securely fastened with devices of sufficient strength and design to prevent shifting of the cargo while in transit.

13:20-23.3 Wood composition devices

(a) When made of wood, these items must be of sound wood, having sufficient strength for the application involved.

(b) They must be secured in position to prevent loosening, rocking or shifting.

(c) When wood is used, it must be free from imperfections which decrease its strength or interfere with proper nailing, and it must have sufficient strength to adequately support the cargo. Other materials having equivalent strength may also be used.

13:20-23.4 Cables

(a) Where cable is used, the ends must be secured. Cable must be protected at all sharp corners, and where a thimble is used to prevent cutting or breaking at a sharp turn, it must be secured.

(b) Cable must be properly tightened and secured to prevent working loose.

13:20-23.5 High tension bands or wires

(a) High-tension bands, or wires, encircling the load must be machine-tensioned, sealed or twist-tied on top of load when positioned, and located as far from end of load as practical. When high-tension bands or wires are attached to stake pockets, cargo strap anchors or other means of attachments, they must be machine-tensioned, sealed, or twist-tied.

(b) The welding of high-tension bands is prohibited.

(c) The use of common wire, of the reuse of high-tension bands, or high-tension wires is prohibited.

13:20-23.6 Fasteners

Fasteners, and points of attachment to body of vehicle, must be at least as strong as the material used for securement.

13:20-23.7 Working capacity; wear

(a) Ropes, chains or cables made by various manufacturers have different safe working capacities. The circumstances under which the rope, chain or cable is used also affects the breaking strength. Under no circumstances should ropes, chains or cables be loaded to more than the manufacturer's recommended safe working capacity for the loading application involved.

(b) Ropes, chains and cables should be examined frequently and discarded if they show signs of excessive wear.

13:20-23.8 Tiedown materials

Materials used for tiedown purposes when attached to openings or fastenings at sides or ends of vehicle floor shall be secured, and these materials shall have a breaking strength at least equal to that of the material used for the tiedown.

13:20-23.9 Cargo shifting in transit

(a) Cargo shall be tied down to the vehicle with sufficient fastening devices and secured to the vehicle floor at a sufficient number of spread points to prevent shifting of the cargo during transit.

(b) Irregular shaped cargo, such as jetty stones, boulders and the like, shall be individually covered by a strong chain net and individually secured to the vehicle floor at a minimum of four spread points to prevent shifting during transit.

13:20-23.10 Cargo tipping in transit

Machines and other items having a high center of gravity or a narrow base must be secured to prevent them from tipping while in transit.

13:20-23.11 Large materials

Large and heavy materials, such as ingots, moulds, stones and boulders must be loaded with their largest surface areas as a bearing surface on the floor of the vehicle.

13:20-23.12 Center of gravity loading

Cargo must be loaded with the center of gravity as low as possible.

SUBCHAPTER 24. MOTORCYCLES

Authority

Unless otherwise expressly noted, all provisions of this Subchapter 24 of Chapter 20 were adopted by the Director, Division of Motor Vehicles, Department of Law and Public Safety, pursuant to authority delegated at N.J.S.A. 39:4-1.

13:20-24.1 Approval of goggles

(a) After January 1, 1968, no person shall sell, offer for sale, or distribute any goggles or face shields for use by the operators of motorcycles, unless they are of a type approved by the Director of the Division of Motor Vehicles.

(b) After January 1, 1968, no person shall operate a motorcycle without wearing approved-type goggles or an approved-type face shield unless the motorcycle is equipped with an approved-type windscreen.

(c) Letters requesting approval of goggles, face shields or windscreens shall be sent to the Director, Division of Motor Vehicles.

13:20-24.2 Goggles test procedure

(a) The test procedure for goggles shall be the test procedures describes in that portion of the USA Standard Specifications for Head, Eye and Respiratory Protection Z2.1 designated "Eye Protection" which are applicable to all eye protection devices and which are applicable to the following types of goggles being tested:

1. Goggles, eye cup (except welders' and cutters' models);
2. Spectacles, metal or plastic frame;
3. Goggles, flexible fitting;
4. Spectacles, plastic eye shield.

(b) The following modifications shall be applicable:

1. Provisions with respect to selection of eye and face protective devices shall not apply.
2. Language referring to "employees" shall be deemed to refer to motorcycle riders.

13:20-24.3 Goggle approval requirements

(a) No goggles shall be approved unless they shall:

1. Meet the identification requirements set forth in Section 24.4 (Mark on goggles) of this Chapter.
2. Meet the standards established in that portion of the USA Standard Specifications for Head, Eye and Respiratory Protection Z2.1-1959 which are established in Section 24.2 (Goggles test procedure) of this Chapter with respect to that particular type of goggles, except that the goggles shall provide visual clearance to the extent of 105 degrees to each side of the sagittal plane.

13:20-24.4 Mark on goggles

Goggles approved by the Director shall contain on a lens or frame the readily identifiable mark used by the manufacturer to indicate compliance with the specifications of the USA Standard Specifications for Head, Eye and Respiratory Protection Z2.1-1959, and the device shall be permanently labelled with the manufacturer's trade name and number, which shall be the same trade name and number used in the approval application.

13:20-24.5 Test procedure for face shields

(a) The test procedure for face shields shall be the test procedures described in that portion of the USA Standard Specifications for Head, Eye and Respiratory Protection Z2.1-1959 designated "Face Shields".

(b) Portions of that test procedure to be employed in tests under this Section include the following with the exceptions given:

1. Impact resistance, plastic-window face shield, except that the face shield shall be tested while attached to a helmet and the harness of the helmet shall take the place of the crown strap;
2. Penetration resistance, plastic-window face shield;
3. Visible transmittance, plastic windows;
4. Flammability, plastic windows;
5. Disinfection.

13:20-24.6 Face shield approval requirements

(a) A face shield other than one containing a wire screen window, shall be approved only if:

1. It meets the requirements established in the USA Standard Specifications for Head, Eye and Respiratory Protection Z2.1-1959 established for the test procedures required in Section 24.5 (Test procedure for face shields) of this Chapter;
2. The edge of the face shield is smooth, and if the edge is bevelled, it must be dull finished;

3. It meets the window support and marking requirements established in the USA Standard Specifications for Head, Eye and Respiratory Protection Z2.1-1959;

4. It meets the identification requirements of Section 24.7 (Identification mark on face shield) of this Chapter.

13:20-24.7 Identification mark on face shield

Each face shield shall be permanently labelled with the manufacturer's trade name and number, which must be the same trade name and number used in the approval application.

13:20-24.8 Windscreen approval requirements

(a) No windscreen shall be approved unless:

1. The visual material meets the provisions appearing in USA Standard Specifications for Safety Glazing Materials for Glazing Motor Vehicles Operated on Land Highways Z26.1-1966 for Motorcycle Use. For rigid plastic material, Item 4 of Table 1 shall be used; for flexible plastics, Item 6 of Table 1 shall be used;

2. The metal support shall be of a material which shall bend rather than fragment under impact;

3. Covering material, other than visual material, shall be beaded at the edges to prevent fraying; and if cloth shall be tested for flammability according to the procedures of 5902 of specifications of the American Society of Testing Methods;

4. It meets the identification requirements of Section 24.9 (Mark on windscreen) of this Chapter.

13:20-24.9 Mark on windscreen

Each windscreen shall be permanently labelled at an easily visible location with the manufacturer's trade name and number, which shall be the same trade name and number used in the approval application.

13:20-24.10 Approval of helmets

(a) After January 1, 1968, no person shall sell, offer for sale, or distribute any protective helmets for use by the operators of motorcycles, or protective helmets for the use of passengers thereon, unless they are of a type approved by the Director of the Division of Motor Vehicles.

(b) Letters requesting approval of protective helmets shall be sent to the Director, Division of Motor Vehicles.

13:20-24.11 Helmet approval specifications

Applications for approval of safety helmets shall be accompanied by a copy of the Certificate of Approval from the American Association of Motor Vehicle Administrators, showing that the helmet meets the specifications of Standard Z90.1-1966 of the USA Standards Institute, unless the AAMVA has sent a Confirmation Certificate of Approval directly to the New Jersey Division of Motor Vehicles.

13:20-24.12 Reflectorized surface on helmets

Each approved helmet shall have a reflectorized surface on both sides, or have securely affixed thereto reflectorized material on both the left and right side of the helmet. Such reflectorization must cover an area of at least four square inches on each side of the helmet. If reflectorized material, such as one-inch by four-inch strip of reflectorized safety tape is attached to each side of the helmet, it must be affixed in a permanent, weather-proof manner.

13:20-24.13 Identification label on helmets

Each approved helmet shall be permanently labelled with the manufacturer's trade name and number, which shall be the same trade name and number used in the approval application.

13:20-24.14 Helmet straps

Each approved helmet must be equipped with either a neck or chin strap.

13:20-24.15 Test reports

An application for approval of goggles, face shields or windscreens shall be accompanied by a test report from a recognized independent testing laboratory, and such report shall reveal that the goggles, face shields or windscreens for which approval is requested meet or exceed the specifications required by this Subchapter.

13:20-24.16 Samples

One properly identified sample of the goggles, face shields or windscreens must be submitted to the Director at the time the application for approval is made.

13:20-24.17 Notice of approval

When the Director determines that the conditions of approval have been met, a notice of approval, will be issued.

13:20-24.18 Temporary approval

Any goggles, face shield or windscreen, in retail stock on or before March 31, 1968, and sold to a consumer on or before June 30, 1968, may receive temporary approval; provided, however, the manufacturer submits to the Director of the New Jersey Division of Motor Vehicles a notarized statement, signed by a responsible officer of the company, certifying that such device meets the requirements of this Subchapter, and supplies a label which can be permanently affixed to the device showing the manufacturer's trade name and number, which shall be the same trade name and number of the device which has been certified to meet the requirements of this Subchapter.

13:20-24.19 Withdrawal of approval

The right is reserved to withdrawal approval of a product at any time and for any cause deemed reasonable by the

Director, or the Director may require new approvals at any time it is deemed necessary or reasonable.

13:20-24.20 Inspection of motorcycles

(a) Motorcycle registrations commence April 1 and end on the following March 31. These vehicles must be inspected between March 1 and June 30 of the same year. Any such vehicle which is operated after June 30 and does not display a current inspection sticker will be subject to enforcement action.

(b) Motorcycles, new or used, registered in New Jersey for the first time will be issued temporary authorization certificates. These vehicles are required to be inspected within 14 days of the date of issuance of the temporary authorization certificate.

Authority

N.J.S.A. 39:8-1 and 39:8-2

13:20-24.21 Motorcycle license plates and tabs

Effective at the time the 1970 motorcycle registrations are issued, only one license plate and/or one license plate tab shall be issued for each motorcycle, to be displayed on the rear of the motorcycle.

Authority

N.J.S.A. 39:3-33.7

SUBCHAPTER 25. SAFETY GLAZING MATERIAL; OTHER EQUIPMENT**Authority**

N.J.S.A. 39:3-43 and 39:3-75.

Source and Effective Date

R.1986 d.80, effective April 7, 1986.
See: 18 N.J.R. 47(a), 18 N.J.R. 703(a).

Subchapter Historical Note

All provisions of this subchapter became effective prior to September 1, 1969. Amendments became effective January 16, 1981 as R.1981 d.15. See: 12 N.J.R. 606(b), 13 N.J.R. 149(d). This subchapter expired January 16, 1986 pursuant to Executive Order No. 66(1978). New rules became effective April 7, 1986 as R.1986 d.80. See: 18 N.J.R. 47(a), 18 N.J.R. 703(a).

13:20-25.1 Letter requesting approval

A letter requesting approval of a particular device, safety glazing materials or other equipment shall be directed to the Director, Division of Motor Vehicles by the manufacturer of the device, safety glazing material or other equipment.

13:20-25.2 Application for approval; report

Applications for approval shall be accompanied by a report from a recognized independent testing laboratory and such report shall reveal that the device, safety glazing material or other equipment for which approval is requested, meets or exceeds the specifications and standards established by the Society of Automotive Engineers or the American Standards Association, or specifications and standards adopted by the Director or the American Association of Motor Vehicle Administrators.

As amended, R.1981 d.15, eff. January 16, 1981.
See: 12 N.J.R. 606(b), 13 N.J.R. 149(d).

Added: American Association of Motor Vehicle Administrators.

13:20-25.3 Samples

Properly identified samples of a device, safety glazing material or other equipment must be submitted to the Director for test and record purposes.

13:20-25.4 Determination of approval

(a) The Director shall determine from the testing laboratory reports and examination of the item submitted whether or not it meets the established specifications and standards.

(b) The Director shall by letter inform the applicant of his determination.

13:20-25.5 Safety glazing material approval procedure

(a) Standards and specifications for the approval of safety glazing materials shall conform to the American National Standard "Safety Code for Safety Glazing Materials for Glazing Motor Vehicles Operating on Land Highways," Z26.1a-1969, March 7, 1969.

(b) Safety glazing materials conforming to Z26.1-1966 must be used on all motor vehicles manufactured on and after September 1, 1967, and registered in New Jersey, and may be used on vehicles manufactured prior to September 1, 1967.

(c) Those safety glazing materials which were approved prior to the date of this regulation may continue to be used on vehicles manufactured prior to September 1, 1967.

Amended by R.1986 d.80, effective April 7, 1986.

See: 18 N.J.R. 47(a), 18 N.J.R. 703(a).

(a) substantially amended.

Authority

N.J.S.A. 39:31-75

SUBCHAPTER 26. SELF-INSPECTION OF CERTAIN CLASSES OF MOTOR VEHICLES**Authority**

Unless otherwise expressly noted; all provisions of this Subchapter 26 of Chapter 20 were adopted by the Director, Division of Motor Vehicles, Department of Law and Public Safety, pursuant to authority delegated at N.J.S.A. 39:8-10, and were filed and became effective November 2, 1970, as R.1970 d.132. See: 2 N.J.R. 85(d), 2 N.J.R. 101(d).

13:20-26.1 Applicability

The provisions of this Subchapter shall be applicable to all vehicles registered in this State.

13:20-26.2 Definitions

The following words and terms, when used in this Subchapter, shall have the following meanings unless the context clearly indicates otherwise.

"Lessee" means any person under a contract or agreement who exercises control or who operates a motor vehicle under said agreement or contract for 30 days or more.

"Vehicle" means every trailer, semitrailer, pole-trailer; every truck registered at a gross weight in excess of 6,000 pounds, truck-tractor, as defined in N.J.S.A. 39:1-1, and every vehicle registered in this State engaged in interstate commerce which is now or hereafter subject to regulation and license by the Interstate Commerce Commission and/or the Bureau of Motor Carrier Safety of the Federal Highway Administration.

13:20-26.3 Inspection and maintenance

(a) Every owner or lessee of a motor vehicle registered in this State shall systematically inspect and maintain, or cause to be systematically inspected and maintained, all motor vehicles subject to its control, and the accessories, required by Part 393 of the regulations of the Bureau of Motor Carrier Safety of the United States Department of Transportation, to be mounted thereon, to insure that such motor vehicle and accessories are in safe and proper operating condition. A systematic inspection and maintenance record shall be maintained for each vehicle. Such records shall include, at least:

1. An identification of the vehicle including New Jersey registration number, make, model, serial number, and number of tires, their size, and number of ply;
2. A record of inspection and repairs indicating date and nature;
3. A lubrication record;
4. A systematic means for indicating for each vehicle the nature and due date of various inspection and maintenance operations to be performed;

5. If leased or otherwise contracted for, such records shall also include an identification of the lessor or contractor furnishing the motor vehicle.

(b) Any report or record of inspection shall be maintained for a period of 24 months by the owner or lessee and be immediately available upon the request of the Director or any other person authorized to inspect under this Subchapter.

13:20-26.4 Unsafe operations

No owner or lessee shall drive or permit or require a driver to drive any motor vehicle revealed by inspection or operation to be in such condition that its operation would be hazardous or likely to result in a breakdown of the vehicle; nor shall any driver drive a motor vehicle which by reason of its mechanical condition is so imminently hazardous to operate as to be likely to cause an accident or a breakdown of the vehicle.

13:20-26.5 Inspection of motor vehicles

(a) Every State police officer, and every employee of the Division of Motor Vehicles, Department of Law and Public Safety, may enter upon and perform inspections of vehicles in operation upon the highways of this State or at the premises or places of business of the owner or lessee of such vehicles; provided, however, that such officer or employee has been authorized to inspect by the Director of the Division of Motor Vehicles and provided he has been trained in the techniques and procedures of inspection now or hereafter established by the Division of Motor Vehicles.

(b) Reports of the inspection described above shall be submitted to the Director of the Division of Motor Vehicles.

Amended by R.1985 d.174, effective April 15, 1985.
See: 17 N.J.R. 270(a), 17 N.J.R. 971(a).

Substituted "Division of Motor Vehicles" for "Bureau of Motor Carrier Safety".

13:20-26.6 Motor vehicles declared "out-of-service"

(a) Any authorized officer or employee shall declare and mark "out-of-service" any vehicle which by reason of its mechanical condition or loading may cause a breakdown or accident.

(b) Any motor vehicle declared and marked "out-of-service" shall not be operated until all repairs have been satisfactorily completed. The term "operate" as used in this Section shall include towing the vehicle; provided, however, that vehicles marked "out-of-service" may be towed by means of a vehicle using a crane or hoist; and provided further, that the vehicle combination consisting of the emergency towing vehicle and the "out-of-service" vehicle meets the performance requirements of Section 393.52 of the Bureau of Motor Carrier Safety Regulations.

(c) Any authorized officer or employee shall declare and mark "out-of-service-limited movement authorized" any ve-

hicle which has a serious mechanical or loading defect that may cause a breakdown or accident, but which defect does not render the vehicle's continued operation, for limited movement, imminently dangerous.

(d) If a vehicle is declared "out-of-service-limited movement authorized", the inspecting officer or employee, in his discretion, may permit the vehicle to proceed to the nearest acceptable place of repair. The inspecting officer shall record the location of the place of repair, the vehicle's authorized route of movement and the estimated date and time of arrival at the place of repair on the inspection form. Upon arrival at the designated place of repair, a vehicle marked "out-of-service-limited movement authorized" will be considered "out-of-service" as described in subsection (b) of this Section.

(e) No person shall remove any marking indicating a motor vehicle to be "out-of-service" prior to completion of all repairs.

(f) The person or persons completing the repairs required by the "out-of-service" or "out-of-service-limited movement authorized" notice shall certify to the Director the date and the time the required repairs were completed.

As amended, R.1971 d.179, effective October 15, 1971.
See: 3 N.J.R. 180(d), 3 N.J.R. 227(a).

13:20-26.7 Notice to owner or lessee

(a) The driver of any vehicle receiving notice that the vehicle is "out-of-service" shall:

1. Deliver such notice to the owner or lessee operating the vehicle upon his arrival at the next terminal or facility of the owner or lessee, if such arrival occurs within 24 hours.
2. Immediately mail the notice to the owner or lessee if the driver does not arrive at a terminal or facility of the owner or lessee operating the vehicle within 24 hours.

(b) For operating convenience, the owner or lessee may designate any shop, terminal, facility, or person to which it may instruct its drivers to deliver or forward such notice.

(c) It shall be the sole responsibility of the owner or lessee that such notice is returned to the Division of Motor Vehicles in accordance with the terms prescribed thereon and in subsections (d) and (e) of this Section.

(d) The owner or lessee shall carefully examine such notice, and any and all defects noted thereon shall be corrected. The driver's failure to comply with this subsection shall not excuse the owner or lessee from taking appropriate action to correct defects which come to his attention by any means whatsoever.

(e) Within 15 days following the date of the vehicle inspection, the owner or lessee shall forward to the Division a certificate of action taken as a result of said inspection.

13:20-26.8 Damaged vehicles inspection

No owner or lessee shall permit or require a driver to drive nor shall any driver drive a motor vehicle which has been damaged in an accident or by other cause until inspection has been made by a person qualified to ascertain the nature and extent of the damage and the relationship of such damage to the safe operation of the motor vehicle; nor shall such motor vehicle be operated until such person has determined it to be in safe operating condition.

13:20-26.9 Vehicle condition report

(a) Every owner or lessee operating more than one motor vehicle shall require its drivers to report, and every driver shall prepare such a report in writing at the completion of his day's work or tour of duty, list any defect or deficiency of the motor vehicle discovered by the driver or reported to him as would be likely to affect the safety of operation of the motor vehicle or result in its mechanical breakdown or shall indicate that no such defects or deficiencies were discovered by or reported to him.

(b) Such reports shall be carefully examined, the defects reported thereon shall be checked and the report shall be retained by the owner or lessee for a period of 12 months.

13:20-26.10 Recommended forms

(a) The following practices and forms are recommended to motor carriers for consideration as one means of establishing the inspection and maintenance practices which are required by Sections 26.3 through 26.9 of this Chapter.

1. As a convenient means of providing for the report required by Section 26.9 (Vehicle condition report) of this Chapter, the "Driver's Vehicle Condition Report" is suggested. The items are arranged in a logical order of inspection. While the provisions do not require a written inspection report prior to operating, the form may be adapted for such a report by duplicating the text of the form and using an appropriate heading. Changes may be made to suit the particular carrier's operations, such as by providing for the recording of more than one inspection on a single form.

2. As a convenient means for providing the systematic inspection and maintenance records required by Section 26.3 (Inspection and maintenance) of this Chapter, the inspection and Maintenance Reports I and II are suggested, but the provisions do not require any particular type or form of records. Other systems recommended by the vehicle manufacturers are suggested as alternative methods.

3. A cardboard check sheet for each inspection period is recommended to be placed in the garage. Under the suggested system, when the four 1,000-mile inspections have been completed, the mechanic will know that he should perform the 5,000-mile inspection in accordance with the 5,000-mile inspection card. These forms, especially the mileage intervals, are suitable for the average over-the-road operator but changes may be made to adapt them to the individual operation. The items listed may be too numerous for some operations and in such cases, carriers may select items applicable to their own operations. Carriers may alter the recommended mileage figures to suit their needs or inspection periods may be determined on other than a mileage basis such as time or fuel consumption. The fundamental requirement is that there be a systematic inspection and maintenance system.

13:20-26.11 Required inspection and maintenance

(a) The following items of equipment are required to be inspected and maintained at least once every three months:

1. All brake lines and lining;
2. Drive lines;
3. Coupling devices;
4. Tires, wheels, and flaps;
5. Springs;
6. Emergency equipment;
7. Fuel system;
8. Cooling system;
9. Lighting devices, horns, and mirrors;
10. Transmission system;
11. Steering equipment;
12. Axles and the tie-rod assemblies;
13. Clutch;
14. Exhaust system and exhaust emissions; and
15. Glazing and wipers.

13:20-26.12 Standards of inspection

(a) All equipment subject to inspection shall meet the standards now or hereafter prescribed by statute, by regulation of the Director of the Division of Motor Vehicles, and by regulation of the Bureau of Motor Carriers of the Federal Highway Administration.

(b) The Director may, in accordance with the "Administrative Procedure Act," P.L. 1968, c.410 (C.52:14B-1 et seq.), alter or amend any standard if, in his discretion, he finds that such standard is contrary to safe operation.

Amended by R.1985 d.174, effective April 15, 1985.
See: 17 N.J.R. 270(a), 17 N.J.R. 971(a).

Added text "in accordance with ... (C.52:14B-1 et seq.)"; and deleted "upon 30-day notice".

13:20-26.13 Certification

Every owner or lessee must certify to the Director on a form prescribed that he has inspected and maintained his vehicles in conformity to this Subchapter. Such certification shall be made once every 12 months.

13:20-26.14 Additional inspection

None of the prior Sections of this Subchapter shall be construed to limit or deny the Director of the Division of Motor Vehicles the authority to require additional inspection to determine levels of air contaminants from vehicles, nor should any prior Section be construed to abridge any code, rule or regulation now or hereafter promulgated pursuant to Title 26, Chapter 2C of the New Jersey Statutes Annotated, Air Pollution Control Act of 1954.

13:20-26.15 Penalties

Any owner or lessee who violates any provision of this Subchapter may be subject to the suspension or revocation of his New Jersey registration and license privileges and/or may be subject to the loss of the self-inspection privilege authorized by this subchapter.

13:20-26.16 State inspection required; time for inspection

(a) Notwithstanding, and in addition to any other provision or requirement of this chapter, all "vehicles" except trailers, semi-trailers, pole trailers and diesel trucks registered at a gross weight of 10,000 lbs. or more and diesel truck tractors as defined in N.J.S.A. 39:1-1 shall be required to be inspected at State inspection stations or by examiners designated by the Director.

(b) The expiration of the windshield inspection sticker of each vehicle shall be the last day of the month in which the vehicle registration expires. Each such vehicle shall be presented for inspection after registration has been renewed and prior to the expiration date shown on the windshield inspection sticker.

New Rule, R.1985 d.174, effective April 15, 1985 (operative July 1, 1985).
See: 17 N.J.R. 270(a), 17 N.J.R. 971(a).

SUBCHAPTER 27. (RESERVED)

Source and Effective Date

R.1971 d.86, eff. June 1, 1971.
See: 3 N.J.R. 84(a), 3 N.J.R. 136(d).
As amended, R.1978 d.66, eff. February 22, 1978.
See: 10 N.J.R. 17(b), 10 N.J.R. 122(a).

SUBCHAPTER 28. INSPECTION OF NEW MOTOR VEHICLES

Authority

N.J.S.A. 39:8-2.

Source and Effective Date

R.1985 d.379, effective June 27, 1985.
See: 17 N.J.R. 1059(a), 17 N.J.R. 1901(a).

Subchapter Historical Note

All provisions of this subchapter became effective October 1, 1971 as R.1971 d.144. See: 3 N.J.R. 112(a), 3 N.J.R. 181(a). Amendments became effective December 10, 1971 as R.1971 d.222. See: 3 N.J.R. 226(a), 4 N.J.R. 10(a). Further amendments became effective July 1, 1975 as R.1975 d.174. See: 7 N.J.R. 233(c), 7 N.J.R. 343(b). Further amendments became effective August 5, 1980 as R.1980 d.345. See: 12 N.J.R. 280(c), 12 N.J.R. 551(c). Further amendments became effective January 21, 1985 (operative July 1, 1985) as R.1984 d.622. See: 16 N.J.R. 2500(a), 17 N.J.R. 203(a). This subchapter was re-adopted pursuant to Executive Order 66(1978) effective June 27, 1985 as R.1985 d.379. See: 17 N.J.R. 1059(a), 17 N.J.R. 1901(a). See chapter and section levels for further amendments.

13:20-28.1 Purpose

(a) The purpose of this subchapter is to effect increased equipment and vehicular safety by requiring new motor vehicle dealers to inspect new motor vehicles prior to delivery to an ultimate purchaser in New Jersey.

(b) Such inspection shall be deemed, when performed in conformity with this subchapter, to satisfy the requirements of N.J.S.A. 39:8-1.

13:20-28.2 Applicability

The provisions of this subchapter shall be applicable to all new motor vehicle dealers licensed by the Director.

13:20-28.3 Definitions

The following words and terms, when used in this subchapter, shall have the following meanings unless the context clearly indicates otherwise. (Note: Any other term used in this subchapter and not defined within this section shall have the meaning as defined in N.J.S.A. 39:1-1 et seq.)

"Director" means the Director of the Division of Motor Vehicles in the Department of Law and Public Safety.

"Mileage recording instrument" means an instrument mounted in the passenger compartment of a vehicle which will accurately measure and record the mileage traversed by the vehicle.

"New car dealer" or "new motorcycle dealer" means a dealer licensed pursuant to N.J.S.A. 39:10-19, to sell new passenger vehicles or new motorcycles, his employees and/or agents.

“New motor vehicle dealer” means a dealer licensed pursuant to N.J.S.A. 39:10–19, to sell new motor vehicles, his employees and/or agents.

“New passenger vehicle” means every new vehicle, regardless of registration class, used and designed for the transportation of passengers, except motorcycles, omnibuses, school buses and vehicles that run upon rails or tracks.

“Pre-delivery check list” means a list of items and procedures which a new car dealer or new motorcycle dealer is required or recommended by a manufacturer to check or follow prior to delivery of a new vehicle to a purchaser.

“Ultimate purchaser” means any person, other than a motor vehicle dealer purchasing in his capacity as a motor vehicle dealer, who in good faith purchases a motor vehicle for purposes other than for resale as a motor vehicle dealer.

13:20–28.4 Manufacturers’ new vehicle inspection procedure

(a) Every new motor vehicle dealer shall, prior to delivery to an ultimate purchaser of any new motor vehicle, inspect the safety devices on such vehicles and perform such services as may be necessary so that such vehicle conforms to certain specifications established by the manufacturer and contained in its pre-delivery check list.

(b) Completion of the pre-delivery inspection procedure required or recommended by a manufacturer shall be deemed by the Director, unless and until otherwise stated, to render that vehicle sale for operation on the highways, roadways and other quasipublic areas of New Jersey.

(c) Any new motorcycle dealer which inspects new motorcycles under the provisions of this subchapter must be licensed as a motorcycle reinspection center pursuant to N.J.A.C. 13:20–32.1 et seq.

13:20–28.5 United States Transportation Department standards

(a) All new motor vehicles subject to inspection shall meet the standards now or hereafter prescribed by the manufacturer or by statute or by regulation of the Director or by the standards prescribed by the U.S. Department of Transportation.

(b) In the event of any inconsistency or conflict between the manufacturer’s specifications and any standard or rule adopted by the U.S. Department of Transportation or by statute or by regulation of the Director, the standard or rule adopted by the U.S. Department of Transportation or by statute or by regulation of the Director shall take precedence.

13:20–28.6 Decal

(a) Every new motor vehicle dealer shall, after satisfactory completion of inspection, affix a decal or other indication of successful inspection as the Director may prescribe, upon such vehicle.

(b) Any new motor vehicle receiving a decal or other indication of successful inspection shall next be inspected one year from the date of initial registration of that vehicle.

(c) In the event that the ultimate purchaser of any new motor vehicle transfers registration from a previously owned vehicle registered in his name to a new motor vehicle, the new motor vehicle dealer shall affix a decal or other indication of inspection to such vehicle, which shall indicate that such vehicle shall next be inspected at the conclusion of the period represented by the unexpired period of time of the transferred registration plus one year.

(d) In the event that the ultimate purchaser of any new motor vehicle registers that vehicle with a fixed registration expiration date, the dealer shall affix a decal or other indication of inspection to such vehicle, which shall indicate that such vehicle shall next be inspected at the conclusion of the period represented by the expiration date of the registration plus one year.

13:20–28.7 Compliance

No new motor vehicle dealer may deliver a vehicle to an ultimate purchaser until such vehicle has been found to be in safe operating condition as determined by compliance with the inspection standards established by the provisions of this subchapter.

13:20–28.8 Evidence of compliance

(a) Completion by a new motor vehicle dealer of a manufacturer’s pre-delivery check list or report shall be evidence of compliance with the provisions of this subchapter.

(b) Such pre-delivery check list or report shall be retained by the new motor vehicle dealer for a period of at least three years from the date of inspection.

13:20–28.9 Recommended practices and forms

The pre-delivery check list used by a new motor vehicle dealer shall indicate the place and date of inspection, the person or persons performing such inspection, and compliance with the standards of safety established by this subchapter.

13:20–28.10 Additional inspection

Nothing in this subchapter shall be construed to limit or deny the Director to require any additional inspection, including an inspection to assure the proper functioning of emission control devices or systems of new motor vehicles, nor shall this subchapter be construed to abridge any code, rule or regulation now or hereafter promulgated pursuant to Title 26, Chapter 2C of the New Jersey Statutes Annotated, “Air Pollution Control Act of 1954.”

13:20-28.11 Determination of compliance by Director

The Director or any of his designees may enter upon the premises of any new motor vehicle dealer to determine compliance with any section of this subchapter.

13:20-28.12 Violation

Any new motor vehicle dealer, who violates any provision of this subchapter shall be subject, after notice and hearing, to the suspension or revocation of his New Jersey dealer license.

SUBCHAPTER 29. MOBILE INSPECTION UNIT**Authority**

Unless otherwise expressly noted, all provisions of this subchapter were filed and became effective June 1, 1972, as R.1972 d.106. See: N.J.R. 105(b), 4 N.J.R. 165(b).

13:20-29.1 Mobile Inspection Unit

There is hereby created in the Bureau of Vehicle Inspection, to the Division of Motor Vehicles, a Mobile Inspection Unit which is authorized to set-up and conduct random roadside inspections of vehicles registered in New Jersey for the purpose of fostering highway safety.

Case Notes

Record was insufficient to properly address constitutionality of random roadside examination of vehicles for safety violations. *State v. Kadelak*, 258 N.J.Super. 599, 610 A.2d 916 (A.D.1992).

13:20-29.2 Procedures

(a) Vehicles inspected, pursuant to the authority of N.J.A.C. 13:20-29.1, which are found to be in safe operating condition will be allowed to proceed and no additional marking will be placed upon the vehicle.

(b) Vehicles inspected and found to be defective, in one or more ways, shall be marked with the same type of inspection sticker that they would receive had they been processed through a permanent inspection station maintained by this Division. These vehicles will be required to have the necessary repairs made and to return to any State-operated inspection station within the period of time indicated on the inspection sticker.

Case Notes

Record was insufficient to properly address constitutionality of random roadside examination of vehicles for safety violations. *State v. Kadelak*, 258 N.J.Super. 599, 610 A.2d 916 (A.D.1992).

13:20-29.3 Penalty

Vehicles found to be defective and so marked which continue to operate beyond the period provided for on the inspection sticker, shall be subject to the penalties now provided in Title 39 of the Statutes of New Jersey.

Case Notes

Record was insufficient to properly address constitutionality of random roadside examination of vehicles for safety violations. *State v. Kadelak*, 258 N.J.Super. 599, 610 A.2d 916 (A.D.1992).

SUBCHAPTER 30. SUPPLEMENTAL INSPECTION OF SCHOOL BUSES**Authority**

Unless otherwise expressly noted, all provisions of this Subchapter 30 were filed and became effective August 7, 1972 as R.1972 d.154. See: 4 N.J.R. 163(a), 4 N.J.R. 223(b).

13:20-30.1 Applicability

The provisions of this Subchapter shall be applicable to all school buses registered in this State, except buses which are also used for the transportation of passengers for hire and which are subject to inspection by the New Jersey Department of Public Utilities.

13:20-30.2 Definitions

The following words and terms, when used in this Subchapter, shall have the following meanings, unless the context clearly indicates otherwise.

“Lessee” means any person under a contract or agreement who exercises control or who operates a school bus under said agreement or contract for 30 days or more.

“Private person” means anyone other than a Board of Education or the State or a political subdivision thereof.

“School bus” means every motor vehicle operated by, or under contract with, a public or governmental agency, or religious or other charitable organization or corporation, or privately operated for compensation for the transportation of children to or from school for secular or religious education.

13:20-30.3 Inspection and maintenance

(a) Every school bus owned or leased by a private person, Board of Education or the State or a political subdivision thereof, registered in this State, shall be systematically inspected and maintained to insure that such bus and accessories are in safe and proper operating condition.

(b) A systematic inspection maintenance record shall be maintained for each vehicle.

(c) The minimum inspection to be performed shall be in accordance with the vehicle manufacturers’ maintenance requirements.

(d) Such records shall include, at least:

1. An identification of the vehicle including New Jersey registration number, make, model, serial number and number of tires, their size and number of ply;

2. A record of inspection and repairs indicating their date and nature;

3. A lubrication record;

4. A systematic means for indicating for each school bus the nature and due date of various inspection and maintenance operations to be performed;

5. If leased or otherwise contracted for, such records shall also include an identification of the lessor or contractor furnishing the school bus;

6. Daily vehicle condition report by a driver.

(e) Any report or record of inspection shall be maintained for the life of the vehicle inspected and shall be available for inspection to the Division of Motor Vehicles.

(f) All of the records stated in this Section shall be available for inspection to the State Department of Education, Bureau of Pupil Transportation.

13:20-30.4 Unsafe operations forbidden

No owner or lessee whether private person, Board of Education, the State or a political subdivision thereof shall drive or permit or require a driver to drive any school bus revealed by inspection or operation to be in such condition that its operation would be hazardous or likely to result in a breakdown of the vehicle nor shall any driver drive a school bus which by reason of its mechanical condition is so imminently hazardous to operate as to be likely to cause an accident or a breakdown of the vehicle.

13:20-30.5 Inspection of school buses in operation

(a) Every motor vehicle officer, every State police officer, every employee of the Division of Motor Vehicles, Department of Law and Public Safety either at a time deemed reasonable and necessary in the judgment of the Director of the Division of Motor Vehicles, or at the request of the Bureau of Pupil Transportation of the Department of Education may enter upon and perform inspections of school buses in operation upon the highways of this State or at the premises or places of business of the owner or lessee of such vehicles provided, however, that such officer or employee has been authorized to inspect by the Director of the Division of Motor Vehicles and provided he has been trained in the techniques and procedures of inspection and has his certification card.

(b) Reports of the inspection described in subsection (a) of this Section shall be submitted to the Director of the Division of Motor Vehicles and to the Bureau of Pupil Transportation of the Department of Education. Such reports shall remain on file in the Division of Motor Vehicles and may be considered confidential in the event that further investigation is deemed necessary.

(c) Any authorized officer or employee shall declare and mark "out-of-service" any school bus which by reason of its mechanical condition may cause a breakdown or accident.

(d) Any school bus declared and marked "out-of-service" shall not be operated until all repairs have been satisfactorily completed. The term "operate" as used in this Section shall include towing the vehicle; provided however, that vehicles marked "out-of-service" may be towed by means of a vehicle using a crane or hoist; and provided further, that the vehicle combination consisting of the emergency towing vehicle and the "out-of-service" vehicle meets the performance requirements of N.J.S.A. 39:3-68.

(e) No person shall remove any marking indicating a school bus to be "out-of-service" prior to completion of all repairs.

(f) The person or persons completing the repairs required by the "out-of-service" notice shall certify to the Director the date and the time the required repairs were completed.

(g) No persons may be transported in a vehicle declared "out-of-service" prior to completion of all repairs.

(h) The driver of any school bus receiving notice that the vehicle is "out-of-service" shall deliver such notice to the owner or lessee operating the vehicle upon his arrival at the next terminal or facility of the owner or lessee. It shall be the sole responsibility of the owner or lessee that such notice is returned to the Division of Motor Vehicles in accordance with the terms prescribed thereon and in subsections (d) and (e) of this Section.

(i) The owner or lessee shall carefully examine such notice. Any and all defects noted thereon shall be corrected. The driver's failure to comply with this Section shall not excuse the owner or lessee from taking appropriate action to correct defects which come to his attention by any means whatsoever.

(j) Within 15 days following the date of the vehicle inspection, the owner or lessee shall forward to the Division a certificate of action taken as a result of said inspection.

13:20-30.6 Damaged vehicles inspection

No owner or lessee shall permit or require a driver to drive nor shall any driver drive a school bus which has been damaged in an accident or by other cause until inspection has been made by a person qualified to ascertain the nature and extent of the damage and the relationship of such damage to the safe operation of the school bus nor shall such school bus be operated until such person has determined it to be in safe operating condition.

13:20-30.7 Vehicle condition report by driver

(a) Every owner or lessee operating one or more school buses shall require its drivers to report and every driver shall prepare such a report in writing at the beginning of his day's work or tour of duty, which report shall list any defect or deficiency of the school bus discovered by said driver as would be likely to affect the safety of operation of the school bus or result in its mechanical breakdown or shall indicate that no such defects or deficiencies were discovered by him.

(b) Such reports shall be carefully examined, the defects reported thereon shall be checked and the report shall become a part of the permanent records required to be maintained under Section 30.3 (Inspection and maintenance) of this Chapter.

13:20-30.8 Required practices

(a) The following items of equipment are required to be inspected and maintained at least once every three months:

1. All brake-lines and lining;
2. Drive lines;
3. Doors, aisles and seats;
4. Tires, wheels and flaps;
5. Springs;
6. Emergency equipment;
7. Fuel system;
8. Cooling system;
9. Lighting devices, horns and mirrors;
10. Transmission system;
11. Steering equipment;
12. Axles and the tie rod assemblies;
13. Clutch;
14. Exhaust system;
15. Glazing and wipers;
16. Safety equipment required by New Jersey Department of Education.

13:20-30.9 Standards; alteration of standards

(a) All equipment subject to inspection shall meet the standards now or hereafter prescribed by statute, by regulation of the Director of the Division of Motor Vehicles, and by regulation of the New Jersey Department of Education.

(b) The Director may alter or amend any standard if, in his discretion, he finds that such standard is contrary to safe operation.

13:20-30.10 Certification

(a) Every owner or lessee must certify to the Director on a form prescribed that he has inspected and maintained his vehicles in conformity to this subchapter.

(b) Such certification shall be made once every 12 months.

13:20-30.11 Penalties

Any owner or lessee who violates any provision of this subchapter may be subject to the suspension or revocation of his New Jersey registration and license privileges.

**SUBCHAPTER 31. PRIVATE INSPECTION
CENTER LICENSING**
Authority

N.J.S.A. 39:8-10, 39:8-11, 39:8-23 and 39:8-40.

Source and Effective Date

R.1991 d.253, effective May 6, 1991.
See: 23 N.J.R. 387(a), 23 N.J.R. 1417(b).

Subchapter Historical Note

All provisions of this subchapter "Alcohol-countermeasures regulations" were adopted pursuant to authority of N.J.S.A. 39:3-10 and 39:5-30 and were filed on December 14, 1972 as R.1972 d.255 to become effective December 15, 1972. See: 4 N.J.R. 273(a), 5 N.J.R. 18(c). Amendments were filed and became effective January 8, 1979 as R.1979 d.4. See: 10 N.J.R. 508(a), 11 N.J.R. 78(b). Amendments became effective February 7, 1983 as R.1983 d.19. See: 14 N.J.R. 1195(a), 15 N.J.R. 156(b). This subchapter was readopted pursuant to Executive Order 66(1978) effective January 4, 1984 with amendments effective February 6, 1984 as R.1984 d.7. See: 15 N.J.R. 1923(a), 16 N.J.R. 247(b). Pursuant to P.L. 1984, c.243 (N.J.S.A. 26:2B-9.1), the Bureau of Alcohol Countermeasures was transferred to the Department of Health. N.J.A.C. 13:20-31 was recodified to the Department of Health N.J.A.C. 8:66-1.

13:20-31.1 Restriction of initial licensing

(a) Notwithstanding any other provision of this chapter to the contrary, no initial private inspection center license authorizing such licensee to initially inspect and reinspect motor vehicles in this State pursuant to N.J.S.A. 39:8-1 et seq. shall be issued by the Division of Motor Vehicles to any person or business applying for same after May 16, 1991, with the following exception:

1. An initial private inspection center license may be issued by the Division of Motor Vehicles to a person or business applying for same after May 16, 1991 if the applicant is seeking such licensure for a business which it has purchased which was licensed as a private inspection center on the date of such purchase, provided:

- i. The applicant meets all applicable legal requirements for such licensure;

ii. The application for such licensure is submitted to the Division of Motor Vehicles not more than 30 days after the date of purchase;

iii. The existing private inspection center license is not to be relocated by the seller to another location pursuant to (b) below; and

iv. The purchase included the real estate or leasehold interest of the existing licensee or the applicant has entered into a lease with the owner of the real estate on which the seller conducted business.

(b) Nothing in this section is intended to restrict or in any way affect the application for renewal of a private inspection center license by a person or business, or the issuance of such renewal licenses by the Division of Motor Vehicles, or the relocation of a licensed private inspection center, or the restoration by the Division of Motor Vehicles of a private inspection center license which had been suspended or revoked.

Administrative Correction to (a).
See: N.J.R. 1683(a).

SUBCHAPTER 32. MOTOR VEHICLE REINSPECTION CENTERS

Authority

Unless otherwise expressly noted, all provisions of this Subchapter were adopted pursuant to authority of N.J.S.A. 39:8-2 et seq. and were filed and became effective on November 3, 1975, as R.1975 d.333.
See: 7 N.J.R. 433(b), 7 N.J.R. 570(c).

13:20-32.1 License required; license classes

(a) Reinspection centers shall be licensed by the Director prior to engaging in the service of certifying that vehicles initially rejected at a State motor vehicle inspection station have been adjusted, corrected or repaired so as to conform to the standards established by law or regulation.

(b) Reinspection centers shall be licensed in the following classes;

1. Class I licenses shall be issued to reinspection centers to engage in the certification of passenger automobiles, trucks registered for not more than 6,000 pounds, and buses, except school buses and buses subject to the jurisdiction of the Department of Public Utilities.

2. Class II licenses shall be issued to owners or lessees of fleets of 50 or more vehicles (except school buses and buses subject to the jurisdiction of the Department of Public Utilities) which are subject to annual state inspection.

3. Class III licenses shall be issued to reinspection centers to engage in the certification of motorcycles only.

13:20-32.2 Service limits

(a) Class I licenses may be issued to provide "full service" in all vehicle rejection categories or "limited service" in one or more of the following categories:

1. Engine emissions;
2. Brake system;
3. Exhaust system;
4. Steering, suspension, tires and wheels;
5. Glass (windshield, windows);
6. Electrical: All switches, signals, wipers, lenses and lights, including headlight installation and alignment;
7. Miscellaneous: Any rejected item not in other categories.

(b) Class II licenses authorize certification in all vehicle rejection categories, but limited to vehicles owned or operated by the licensee.

(c) Class III licenses authorize certification in all motorcycle rejection categories.

13:20-32.3 Facilities and equipment

(a) Licensed inspection centers must be housed in a building having a garage-type entrance and one or more service bays.

(b) An engine emissions analyzer, approved by the Department of Environmental Protection must be available on the premises of all Class I "full service" centers, all Class II centers, and all Class I "limited service" centers licensed to certify repairs in the engine emission category. Any license whose analyzer is found to be in need of repair or replacement may use the approved analyzer of another licensed reinspection center during the period when his analyzer is being repaired or until the time he receives a replacement, such period not to exceed 14 days. Such license shall transport the vehicles requiring the engine emissions test to the licensed reinspection center and shall certify them when such test has been made. He shall keep a record of each emissions reinspection made with another licensed reinspection center's analyzer showing the date the reinspection was made, the vehicle, the name and license number of the licensed reinspection center whose analyzer he is using. He shall also provide proof upon request that he has contracted for the repair or replacement of the defective analyzer. In no case shall the license certify the emissions of any vehicle unless he or his employee has personally made the emissions tests. Notwithstanding the fact that the licensee is using the analyzer of another licensed reinspection center, he shall take all necessary precautions and do whatever is reasonable and practicable to determine that the analyzer being used is accurate.

(c) A vehicle lift or heavy duty floor jack must be available on the premises of all Class I "full service" centers, all Class II centers, and all Class I "limited service" centers licensed to certify repairs in the brake, steering and suspension system categories.

(d) Headlight aiming equipment, for example, a photoelectric cell aimer, a mechanical aimer or an aiming chart, must be available on the premises of all Class I "full service" centers, all Class II centers, all Class III centers and all Class I "limited service" centers licensed to certify repairs in the electrical category.

(e) Brake testing equipment, for example, a drive-on horizontal scale or rollertype tester, must be available on the premises of all Class I "full service" centers, all Class II centers, all Class III centers and all Class I "limited service" centers licensed to certify repairs in the brake system category. Provided, however, that this brake testing equipment requirements shall be waived where the licensee intends to road test brake repairs.

(f) A tire tread depth gauge calibrated in 32nds of an inch shall be available on the premises of Class I "full service" centers, Class II centers, Class III centers and Class I "limited service" centers licensed to certify in the steering, suspension, tires and wheels category.

As amended, R.1978 d.67, eff. February 22, 1978.
See: 10 N.J.R. 17(a), 10 N.J.R. 122(b).

13:20-32.4 Applicant qualifications

(a) An applicant must, in the director's discretion, be a proper person to hold a reinspection center license.

(b) In assessing whether an applicant is a proper person, the director may consider the character and responsibility of the individual applicant (if natural person), of the individual partners (if partnership) or of the offices and other controlling individuals (if corporation) or anyone else employed by or otherwise associated in business with the applicant.

(c) An applicant must have legal capacity to contract, to be sued and to be liable for all debts.

(d) No applicant shall be entitled to licensure who is under 18 years of age.

(e) The applicant or someone in his employ shall be qualified as provided in N.J.A.C. 13:20-32.14.

As amended, R.1983 d.525, eff. November 1, 1983.
See: 15 N.J.R. 1608(a), 15 N.J.R. 1946(b).

Originally filed as an emergency adoption (R.1983 d.404) on September 2, 1983. Readopted as R.1983 d.525. In (e), deleted old qualification requirements and added requirements provided in N.J.A.C. 13:20-32.14.

13:20-32.5 Insurance required

(a) Every licensee is required to maintain liability insurance coverage in the following minimum amounts:

1. For damage to property in any one occurrence: \$50,000;
2. For injury to, or death of any one person in any one occurrence: \$100,000;
3. For injury to, or death of two or more persons in any one occurrence: \$300,000.

(b) An applicant shall file, together with his application, proof of insurance coverage in the form of a certificate issued by the carrier containing a clause that ten days prior notice will be given to the Division of any cancellation or termination of the policy.

(c) Failure to maintain such insurance coverage shall be cause for immediate suspension of license.

13:20-32.6 License application, form, content and fee

(a) Applications for licenses shall be made on forms provided by the division, consisting of two parts, principal and supplementary.

1. The principal application shall elicit information bearing upon the nature and location of the applicant's business, the experience of the applicant and his employees, and the nature of the reinspection license sought by the applicant.

2. The supplementary application shall cover the background of the owner and each partner of an unincorporated business and each principal executive officer and controlling individual of a corporation or association and shall be filed by each such owner, partner, controlling individual or officer.

(b) A non-refundable fee of \$15.00 paid by check or money order payable to "New Jersey Division of Motor Vehicles" shall be submitted with the application.

(c) Any qualified person may file application for and be licensed in both Class I (full or limited service) and Class III in which case the fee shall be \$15.00 for each class.

(d) When a person licensed in Class I "limited service" makes application to amend the license so as to add rejection categories, a fee of \$15.00 shall be paid with the application.

As amended, R.1983 d.20, eff. February 7, 1983.
See: 14 N.J.R. 1196(a), 15 N.J.R. 156(c).
Increased fee from \$10.00 to \$15.00.

13:20-32.7 License, display of; content

(a) A current reinspection center license certificate shall be conspicuously displayed in the licensee's place of business.

(b) License certificates shall describe the class and rejection categories to which the reinspection center is limited.

13:20-32.8 Identifying mark; reinspection center

(a) An identifying mark bearing the logogram of the Division of Motor Vehicles shall be issued to each licensee except Class II.

(b) Said mark shall be conspicuously displayed on the outside of the reinspection center.

(c) The licensee shall post a sign beneath said mark describing the services offered which shall correspond to the class and limits set forth in the license.

(d) Each licensee shall affix the center's license number in the space provided on the mark.

13:20-32.9 Reinspection approval stickers

(a) The approval sticker shall be composed of two parts, as follows:

1. A base sticker indicating the calendar year validity and sticker serial number; and
2. A registration renewal and inspection month number in the form of an insert which is to be applied to the base sticker.

(b) Base stickers may be purchased by a licensee, by mail or in person, from the Division of Motor Vehicles, Bureau of Vehicle Inspection, Reinspection Unit, 25 South Montgomery Street, Trenton, New Jersey 08666.

(c) Base stickers shall be purchased at \$1.00 per sticker in quantities of 50 or more.

(d) Registration renewal and inspection month inserts shall be provided to licensees at no charge.

(e) Upon the return of base stickers which are not used during the applicable calendar-year, a credit of \$1.00 per sticker shall be given the licensee toward the purchase of current base stickers.

(f) Base stickers shall be secured in a locked place of limited access, such as a safe, cabinet or desk drawer. The licensee is solely responsible for the security of the base stickers. Failure to take necessary security precautions to protect the stickers against loss or theft shall be cause of suspension or revocation of the license.

(g) Base stickers shall be placed on a vehicle only after reinspection has been completed.

(h) When defects detected at State inspection have been repaired or adjusted by the licensee or by an employee on the licensee's payroll, the licensee shall insure, prior to placement of an approval sticker on the vehicle, that the individual who performed the repair or adjustment work has signed his name on the State inspection rejection card next to the application rejection category. When defects detected at State inspection have been repaired by someone other than the licensee or employees on the payroll of the licensee, the licensee shall insure, prior to placement of an approval sticker, that the person or persons who reinspects the vehicle have signed the state inspection rejection card at the bottom of its reverse side.

(i) State inspection rejection cards shall be kept separate and apart from the base stickers and shall be kept in a locked place of limited access, such as a safe, desk drawer or cabinet.

(j) The serial number of the base sticker and the date of issue shall be recorded upon the corresponding state inspection rejection card.

(k) Base stickers shall be used in numerical sequence.

(l) Defective and voided stickers shall be returned to the Division of Motor Vehicles within two business days of discovery.

(m) Upon discovering that base stickers have been stolen or are otherwise unaccounted for, the licensee shall notify the Reinspection Unit within one business day of discovery.

(n) Upon discontinuation of the reinspection certification service by the licensee, all unused base stickers and registration renewal and inspection month inserts shall be forwarded to the Division of Motor Vehicles within 24 hours of discontinuance. In such cases, fees paid for unused base stickers will be refundable.

(o) Licensees shall be solely accountable for the base stickers and inserts issued to them by the Division of Motor Vehicles.

As amended, R.1983 d.20, effective February 7, 1983.

See: 14 N.J.R. 1196(a), 15 N.J.R. 156(c).

Changed DMV address in (b); changed Licensing section to Reinspection Unit; increased fee from \$0.50 to \$1.00.

13:20-32.10 Records

(a) State inspection rejection cards shall be maintained by the licensee in order corresponding to the base sticker serial number recorded thereon and the date on which the base sticker was issued.

(b) Class I and III licensees shall maintain repair orders and invoices (bills for parts and labor) in the form required by the deceptive automotive repair work and advertising practices regulation (N.J.A.C. 13:45A-1.1 et seq.).

(c) The repair order and invoice number or numbers shall be transcribed onto the state inspection rejection card.

(d) Records required to be maintained by this Section shall remain on file in the licensee's place of business for a period of two years from the date of issuance of the base sticker.

(e) Records required to be maintained by this Section shall be made available by the licensee for examination by employees of the Division of Motor Vehicles at any time during regular business hours. Investigators and other Division of Motor Vehicles personnel shall be granted access to the licensee's property during regular business hours.

(f) Failure to permit investigators and other Division of Motor Vehicles personnel on the premises of the licensee during regular business hours for purposes of conducting reasonable investigations shall be cause for suspension. Such investigations shall include, but shall not be limited to, discussions with customers, examination of machinery, questioning of employees and the employment of such other investigatory techniques as may be necessary for the enforcement of this regulation and the provisions of Title 39, Chapter 8.

13:20-32.11 Certification for reinspection

(a) Each licensed reinspection center shall have the authority to reinspect vehicles covered by the particular center's license and to certify that specific items for which a vehicle was rejected at State inspection have been corrected to conform with the technical standards set forth in the "Manual on Procedures and Standards for Use by Licensed Reinspection Centers". Provided, however, that Class I "limited service" centers may reinspect and certify vehicles only when all of the items for which the vehicle was rejected as state inspection are within the categories enumerated on the center's "limited service" license.

(b) No licensee shall certify that items for which a vehicle was rejected at State inspection have been corrected unless the licensee or an employee on the payroll of the licensee has inspected the vehicle and has determined that all defects detected at State inspection have been corrected to conform with the technical standards set forth in the "manual".

(c) Certification shall be evidenced by the affixation of a reinspection approval sticker on the vehicle in the place specified in the "manual" and by stamping a reinspection approval imprint on the reverse side of the vehicle's registration certificate. Each licensee shall possess a stamp for the purpose of effecting said reinspection approval imprint. Failure to take necessary security precautions to protect the stamp against loss or theft shall be cause for suspension or revocation of the license.

(d) Certification of a vehicle by the licensee or his employee shall constitute the licensee's representation that the licensee or an employee on the licensee's payroll has in-

spected the vehicle and has determined that the defects detected at State inspection have been corrected to conform with the standards set forth in the "manual".

(e) Class I licensees, upon being presented with a vehicle for repair or adjustment of defects detected at State inspection and for certification, may occasionally opt to "farm out" part of the repair or adjustment work; that is, to have the repair or adjustment work performed with the equipment or by the employees of another firm. Provided, however, that Class I "limited service" centers may exercise said "farming out" option only when all of the items for which the vehicle was rejected at State inspection are within the categories enumerated on the center's "limited service" license. Provided, also, that Class I centers licensed to reinspect glass may always "farm out" their glass repair work.

(f) Repair or adjustment work performed under this "farming out" option shall be deemed to be work performed under the direction of the Class I licensee. Exercise of this option shall not relieve the licensee of his ultimate duty, as set forth in subsections (b), (c) and (d) above, to have the sufficiency of all adjustments or repairs inspected by the licensee or by an employee on the licensee's payroll prior to certification of the vehicle.

(g) Licensees who elect to exercise said "farming out" option may be held vicariously liable, in any subsequent license revocation proceeding, for any unconscionable practice perpetrated on the consumer by the party to whom the work was "farmed out".

(h) The fee which a Class I or III licensee may charge the consumer for affixing a certification sticker shall not exceed \$1.50.

(i) The fee which a Class I or III licensee may charge for reinspection of items rejected after State inspection and which have been repaired by the vehicle owner or someone not under the direction of licensee shall not exceed that portion of the licensee's established hourly labor charge for repair service as specified in the "manual" to be the average time required to reinspect a particular rejected item. The consumer shall be notified in advance that the licensee's charge for such reinspection shall not exceed that portion of the labor hourly rate.

(j) Every licensee, other than Class II, shall conspicuously display a schedule of reinspection charges at his place of business and shall file a copy thereof with the Licensing Section of the Certificate of Ownership Bureau. The displayed schedule shall be no smaller than one square foot.

As amended, R.1983 d.20, eff. February 7, 1983.
See: 14 N.J.R. 1196(a), 15 N.J.R. 156(c).
Increased fee from \$1.00 to \$1.50.

13:20-32.12 Denial, suspension and revocation of license

(a) The director may deny, suspend or revoke a reinspection center license or refuse renewal thereof for cause, including but not limited to one or more of the following:

1. Violation of any provision of N.J.S.A. 39:8-2 et seq. or of any regulation adopted thereunder, including a finding of guilt made pursuant to Section 10 of the Act;
2. Fraud, or misrepresentation in securing the license or in conduct of the licensed activity;
3. Making reinspection service charges in excess of those posted in the licensed premises and filed with the director;
4. Conviction of a crime involving moral turpitude;
5. Violation of the Consumer Fraud Act, P.L. 1967, c.301 (C.56:8-1 et seq.) or of any regulation adopted thereunder;
6. Other good cause.

(b) The director may deny, suspend, revoke or refuse renewal of a reinspection center license for a violation of the provisions of N.J.S.A. 39:8-2 et seq., the provision of these regulations or for other good cause pursuant to the Administrative Procedure Act, P.L. 1968, c.40 (C.52:14D-1 et seq.).

(c) Upon suspension or revocation of a reinspection license, the licensee shall forthwith surrender to the director the reinspection center license, the reinspection approval stamp, all unused inspection approval stickers, all state inspection rejection cards, and the reinspection center identification mark.

13:20-32.13 Advertising

Advertising of reinspection service shall include a description of the class and rejection categories in which the center is licensed.

13:20-32.14 Mechanic qualifications

(a) If licensed as a reinspection center on or before June 30, 1983, it shall be sufficient until May 1, 1985 for the licensee to meet the requirements of this rule if the licensee or someone in his employ shall have:

1. At least three years of paid experience in general automotive repair and service; or
2. Have completed a course in automotive repair at an approved vocational school and at least one year of applicable experience; or
3. Have been certified as a general mechanic, or in the applicable categories, by the National Institute for Automotive Service Excellence.

(b) If licensed as a reinspection center subsequent to June 30, 1983, and for all licensees subsequent to May 1, 1985, the licensee or someone in his employ shall meet one of the following criteria:

1. One year experience as a paid automotive mechanic and successful completion of advanced courses in automotive mechanics, specifically designed for and restricted to professionals engaged in the trade which shall meet the requirements of N.J.A.C. 13:20-32.15; or
2. Three or more years paid experience in general automotive repair and service or at least one year paid experience and completion of an automotive repair course at a vocational school may be certified, provided the applicant has successfully passed the National Institute for Automotive Service Excellence test for engine tuneup and at least one other test from the following areas:
 - i. Brakes;
 - ii. Front End;
 - iii. Automotive Electrical Systems.

R.1983 d.525, eff. November 1, 1983.

See: 15 N.J.R. 1608(a), 15 N.J.R. 1946(b).

Originally filed as an emergency adoption (R.1983 d.404) on September 2, 1983. Readopted as R.1983 d.525.

Amended by R.1984 d.619, effective January 21, 1985.

See: 16 N.J.R. 3175(a), 17 N.J.R. 204(a).

Date changed from "prior to May 1, 1983" to "on or before June 30, 1983".

13:20-32.15 Course requirements

(a) To be considered an advanced course pursuant to N.J.A.C. 13:20-32.14, course in automotive mechanics must meet the following criteria:

1. Minimum of 16 contact hours of verified attendance in automotive emissions diagnosis with a minimum of eight hours devoted to hands-on instruction in the following areas:
 - i. Inspection/diagnosis/repair equipment;
 - ii. Hydrocarbon failures;
 - iii. Carbon monoxide failures;
 - iv. Carburetion;
 - v. Current emission control technologies.
2. A minimum of 16 contact hours of verified attendance with a minimum of eight hours devoted to hands-on instruction, in one of the following areas:
 - i. Brakes;
 - ii. Front end;
 - iii. Automotive electrical system.
3. A final competency evaluation consisting of at least:
 - i. Twenty-five questions on automotive emissions diagnosis.

ii. Twenty-five questions in one of the following areas:

- (1) Brakes;
- (2) Front end;
- (3) Automotive electrical systems.

4. An instructor meeting at least one of the following criteria:

- i. Four years experience as a paid automotive mechanic and successful completion of auto mechanics courses as stated in this section;
- ii. A Bachelors degree in Automotive Industrial Arts; or
- iii. An Associates degree in Automotive Industrial Arts may be substituted for two years of the experience requirement.

(b) All necessary equipment, tools, and materials needed for the course shall be accessible to the students.

(c) No more than 15 students per class with no more than five students per available item of demonstration equipment.

(d) Course sponsors may be required to demonstrate that proper measures are being taken for examination security and for proctoring the examination. The student must obtain a score of at least 75 percent in order to pass. The sponsoring organization must provide a copy of the questions and answers for the final examination to the Department of Environmental Protection and Division of Motor Vehicles for review. All questions are to be equally weighed, regardless of grouping.

(e) Courses are subject to unannounced evaluations by New Jersey officials. Courses and examinations which have been approved as complying with these specifications will be kept on file with the Director, Division of Motor Vehicles, Director of Environmental Quality, and Department of Environmental Protection.

(f) The sponsoring organization must issue a certificate for successful course completion. This certification must include the name of the sponsoring organization, the name of the student, the date of issue, and the signature of a sponsoring organization official.

R.1983 d.525, eff. November 1, 1983.

See: 15 N.J.R. 1608(a), 15 N.J.R. 1946(b).

Originally filed as an emergency adoption (R.1983 d.404) on September 2, 1983. Readopted as R.1983 d.525.

SUBCHAPTER 33. ENFORCEMENT SERVICE: STANDARDS AND PROCEDURES TO BE USED BY LICENSED REINSPECTION CENTERS

Authority

N.J.S.A. 39:8-2, 39:8-4.1 and 39:8-23.

Source and Effective Date

R.1984 d.173, eff. April 25, 1984.

See: 16 N.J.R. 503(a), 16 N.J.R. 1280(d).

Subchapter Historical Note

All provisions of this subchapter were filed and became effective on November 3, 1975, as R.1975 d.334. See: 7 N.J.R. 469(d), 7 N.J.R. 570(d).

13:20-33.1 General provisions; Classes I and II licensees

(a) This manual contains information concerning the standards and inspection procedures to be used by Class I and Class II licensed reinspection centers when certifying passenger cars, trucks, and buses which have been repaired after being rejected at a State inspection station.

(b) A separate manual is available for use by Class III licensed reinspection centers when certifying motorcycles (any two or three wheel motor vehicles) which have been repaired after being rejected at a state inspection station.

(c) A reinspection center license authorizes placement of a reinspection sticker on a vehicle as certification that the defects for which the vehicle was rejected at a State inspection station have been repaired, adjusted or corrected by the licensed reinspection center. When such repairs, adjustments or corrections are made, the condition of the rejected item must be brought to the standards described in this manual. Licensed reinspection centers are required to make the checks, tests or inspections as part of the repair job which is standard automotive repair practice. Centers may charge the vehicle owner a fee of not more than \$1.50 for the certification (placing the sticker on the vehicle); however, other charges may not be made except for parts and labor related to the actual repair job.

(d) A reinspection center license also requires reinspection and certification of a vehicle when the owner himself has made the repairs, adjustments or corrections. In such cases, the center must actually reinspect the rejected defects to determine if they conform to the standards described in this manual. If such defects have been brought to standard, a reinspection approval sticker may be placed on the vehicle. A fee for that reinspection service based on the center's established hourly labor charge for repair services may be charged but only that portion of an hour which the division has established to be the average time for reinspection of specific rejected items shown in Table A at the end of the manual.

(e) If the repairs are made in a center, each mechanic who repaired a specific rejected item must sign his name on the State inspection card next to the applicable rejection category. If the repairs were made by the vehicle owner or "farmed out" under a reinspection center license, each mechanic who reinspected the rejected items must sign his name on the reverse side of the card at the bottom.

(f) When a reinspection approval sticker is placed on a vehicle, the center must also stamp the vehicle registration certificate on the reverse side with the following imprint:

NEW JERSEY
DIVISION OF MOTOR VEHICLES
REINSPECTION CENTER

LICENSE NO.
STICKER NO.
DATE

(g) The reinspection center license number, the reinspection approval sticker number and the date must be inserted in the imprint. Each center is required to purchase the above stamp from commercial sources and the center's license number should be made part of that stamp.

(h) If the defective items have been corrected so as to meet the standards shown in this manual, the vehicle may be certified by removing the rejection sticker and replacing it with an approval sticker. The approval sticker shall be placed about three inches from the bottom of the windshield and about four inches from the left side, but in every case, the sticker must be completely visible from the front of the vehicle.

(i) An inspection card may be marked "MUST BE REINSPECTED AT A STATE INSPECTION STATION." When an inspection card is marked in this manner, a licensed reinspection center may not certify the vehicle, but it must be returned to a State inspection station.

(j) The owner of a motor vehicle rejected at a State inspection station because of a safety defect or an exhaust emission defect is required to have the vehicle repaired within 30 days in order to legally operate it in New Jersey. When the nature of the defect is such that the vehicle is obviously very unsafe, the repair must be made within 48 hours.

(k) If a vehicle is presented at a licensed reinspection center after the 30-day period has expired, the licensed reinspection center may reinspect the vehicle and certify it if the rejected items have been corrected, provided a period of not more than 40 days has elapsed since the vehicle was rejected at a State inspection station. If more than 40 days have elapsed, the vehicles must be returned to a State inspection station for a complete reinspection. The motorist may obtain a letter signed by the Director of the Division of Motor Vehicles granting the motorist an extended period in which the vehicle may be legally operated before being subject to reinspection. In order to obtain such a letter, the motorist must write to: Bureau of Vehicle Inspection, Division of Motor Vehicles, 25 South Montgomery Street, Trenton, New Jersey 08666, or telephone 609-292-4873. (An inspection extension letter cannot be issued for vehicles having a "48 hour" sticker.)

(l) If the vehicle has a "48 hour" rejection sticker, the form given to the motorist at the State inspection station must be returned to the Division of Motor Vehicles, 25 South Montgomery Street, Trenton, New Jersey 08666.

(m) In the upper left-hand corner of the inspection card, there are spaces to indicate the issuance of a VI-23 or VI-24 card (samples reproduced following Table A at the end of the manual). The VI-23 card is issued at a State inspection station when a vehicle is presented which has had a valid transfer of registration from a previous owner to a new owner and the registration expires within three months not counting the month of issuance.

(n) The VI-24 card is issued at a State inspection station when a new vehicle is presented (a vehicle which has never been previously registered and the current registration expires within six months not counting the month of issuance).

(o) If a motorist appears at a licensed reinspection center with a VI-23 or VI-24 card and the reinspection center certifies the vehicle, the licensee must stamp the certification on the VI-23 or VI-24 card showing the sticker number, date and the reinspection center license number. The motorist can then take the VI-23 or VI-24 card with the vehicle to the exit end of a State inspection station when the new registration period begins to qualify for inspection sticker replacement.

(p) Class I and II "full service" licensed reinspection centers shall be required to conduct initial motor vehicle inspections for a period of 12 months ending July 1, 1984, pursuant to the regulations and procedures for conducting reinspections.

(q) Class I and II "full service" licensed reinspection centers shall be required to conduct initial motor vehicle inspections for a period of three years ending May 31, 1986, pursuant to the regulations and procedures for conducting reinspections.

(r) A fee which an authorized reinspection center may charge for an initial inspection of a motor vehicle other than a commercial motor vehicle registered in excess of 6,000 pounds shall not exceed one-half of the reinspection center's hourly labor charge. A fee which an authorized reinspection center may charge for an initial inspection of a commercial motor vehicle registered in excess of 6,000 pounds shall not exceed the reinspection center's hourly labor charge and shall be limited to a charge for one hour of labor. The maximum fee for an initial inspection shall be posted on a prominent place on the premises. A copy of the fee shall also be sent to the Licensing Section of the Vehicle Inspection Bureau.

(s) Charges for initial inspections, reinspections and repairs shall be separately stated.

(t) No reinspection center shall require as a condition of performing the initial inspection, that any repairs or adjustments be done by the person, or at the facility of the person performing the inspection.

(u) No service or adjustment shall be performed on the vehicle at the same licensed reinspection center where the vehicle was inspected unless the customer signs a written acknowledgement and waiver that he understands his right to have service and adjustments done elsewhere and expressly waives his rights.

As amended, R.1983 d.547, eff. November 7, 1983.

See: 15 N.J.R. 1963(a).

Originally filed as an emergency adoption (R.1983 d.547) on November 7, 1983.

In (c), increased fee from \$1.00 to \$1.50. Deleted old (h). Recodified old (i) through (q) as new (h) through (p). Added new (q) through (u).

As amended, R.1984 d.10, eff. January 9, 1984.

See: 15 N.J.R. 1963(a), 16 N.J.R. 247(c).

Section substantially amended.

Amended by R.1985 d.20, effective February 4, 1985.

See: 16 N.J.R. 3288(a), 17 N.J.R. 313(a).

(q): Deleted "12 months" and substituted "three years"; changed date from "July 1, 1984" to "May 31, 1986".

Amended by R.1986 d.104, effective April 7, 1986.

See: 18 N.J.R. 158(a), 18 N.J.R. 703(b).

(r) substantially amended.

13:20-33.2 Credentials; Classes I and II licensees

The driver shall present a valid drivers license, a valid New Jersey registration certificate, and an insurance identification card for the vehicle. Photocopies are not acceptable. All forms of credentials must be legible and not altered.

As amended, R.1983 d.547, eff. November 7, 1983.

See: 15 N.J.R. 1963(a).

Originally filed as an emergency adoption (R.1983 d.547) on November 7, 1983.

Deleted old and added new text.

As amended, R.1984 d.10, eff. January 9, 1984.

See: 15 N.J.R. 1963(a), 16 N.J.R. 247(c).

Section deleted, new material added.

13:20-33.3 License plates (identification marks); Classes I and II licensee

(a) Certification of a vehicle may not be refused because the following requirements are not met, but rather the motorist advised to have the condition corrected:

1. License plates shall be clear and distinct and free from grease, dirt or other blurring material so that they are plainly visible at all times of the day and night.

2. License plates shall be securely attached to the vehicle.

3. License plates shall be located not less than 12 inches nor more than 48 inches from the ground in a horizontal position, right side up and right side out.

4. The letters and numbers on the license plates shall agree with the letters and numbers on the registration certificate of the vehicle.

5. A license plate shall not be obstructed by a trailer hitch, snow plow bracket, bumper, bumper guard, sign, emblem, mounting bolt head or reflector.

6. The face area of license plates shall not be covered by glass, plastic or similar material.

7. The inserts used on commercial plates shall show the proper year and be firmly attached to the plates in the proper location.

8. License plates shall not be bent or defaced. However, if the letters and/or numerals are totally illegible the vehicle must not be certified.

13:20-33.4 Steering and suspension and wheel alignment; Classes I and II licensees

(a) A certification shall not be issued for a motor vehicle which has the steering or suspension system in a condition not equivalent to the vehicle manufacturer's specifications.

(b) Front and rear bumper heights must also be in accordance with the vehicle manufacturer's specifications.

(c) Starting with the front wheels in the straight-ahead position, the steering wheel shall be turned in one direction until there is a perceptible movement of a front wheel. When the steering wheel is turned in the other direction, a point on the steering wheel rim shall not move more than three inches before there is a perceptible return movement of the front wheel under observation. (Vehicles with power steering should be in neutral with the engine running for this check.)

(d) With the front end of the vehicle lifted, the front and rear of a front tire shall be properly grasped and an attempt made to turn the tire and wheel assembly right and left. The free movement at the front or rear tread of the tire shall not exceed $\frac{1}{4}$ inch. Then the top and bottom of a front tire shall be grasped and moved in and out. The movement shall not exceed manufacturer's specifications.

(e) The steering wheel shall be turned through the limit of travel in both directions. There shall be no binding or jamming in the steering wheel mechanism.

(f) The steering wheel shall be large enough in diameter so that the vehicle can be steered by a driver of average strength, even though the power steering system (if the vehicle is so equipped) should fail.

(g) There shall be no dangerous wear or breakage of components of the steering or suspension system.

(h) Shock absorbers shall be properly installed and they shall not leak or be defective in a manner which would decrease the safety of the vehicle.

(i) Certificate of a vehicle may not be refused if the wheel alignment is not correct, but rather the motorist advised to have the condition corrected.

13:20-33.5 Front parking lights; Classes I and II licensees

(a) Parking lights must be of a type approved as meeting the standards of the Society of Automotive Engineers. The letters "SAE" and the letter "P" along with the manufacturer's name or trademarks are often on the lens of such lights.

(b) Front parking lights should be white, yellow or amber and securely mounted so as to reduce the likelihood of their being obscured by mud or dust thrown up by the wheels. There should be one front parking light mounted on each side of the vertical centerline of the vehicle at the same height and as far apart as practicable.

(c) Certification of a vehicle shall not be refused for the following reasons, but the motorist advised to have the defects corrected:

1. One or both of the front parking lights are inoperative.
2. A front parking light lens is damaged or missing. (Where front-turn signal lights are combined with the parking lights, the vehicle shall not be refused certification because of a cracked lens, but if the lens is badly shattered or partially or totally missing, the vehicle shall be refused certification.)

13:20-33.6 Glazing; Classes I and II licensees

(a) All glazing used on motor vehicles manufactured after July 1, 1935, must be approved type which is legible and permanently marked with the manufacturer's name, trademark, DOT number or other distinctive designation under which the glazing was approved, so as to be visible when the glazing is installed in the vehicle. The AS number must also appear and the proper type glazing must be used for each location. In general, the approved locations for the various types of glazing are as follows:

1. AS-1: Mandatory in windshields but may be used for any other window in a motor vehicle;
2. AS-2: Anywhere except windshields;
3. AS-3: Rear side windows on buses;
4. AS-4, AS-5, AS-6, and AS-7: Rear windows of convertibles and windows which can be readily removed without the use of tools (not legal for windshields);
5. AS-8 and AS-9: Rear windows of buses;
6. AS-10: Bullet-resistant windshields;
7. AS-11: Bullet-resistant windows except windshields;

8. AS-12 and AS-13: Windows which can be readily removed without the use of tools (not legal for windshields).

(b) All openings in a motor vehicle which were originally manufactured with glazing must be equipped with approved type glazing.

(c) Certification of a vehicle shall not occur if the vehicle has unduly broken, cracked, discolored or deteriorated glazing which causes unsafe visibility for the driver, or if the vehicle has any windows with sharp edges.

(d) A vehicle shall not be certified which has tinted spray or plastic material added to previously approved glazing in the front windshield or windows, vents or deflectors to the immediate right or left of the driver because such condition changes the vision and light transmission properties of the glazing in areas where driver visibility shall not be obscured or obstructed.

(e) A vehicle shall not be certified having a defroster of the "electric element" type installed on a rear window or on any other window unless the heating element is manufactured as an integral part of an approved type safety glass.

(f) The window on the driver's side or some other device must be capable of being readily open to permit arm signals to be made. The presence of approved turn signals does not waive this requirement except on buses and trucks over 80 inches in width.

(g) Any vehicle may have the rear window and/or side windows to the rear of the driver tinted or covered in some manner so as to partially obscure the driver's view and any motor vehicle registered for commercial purposes and constructed on a truck chassis (including Code 15) may have the rear window and/or side windows to the rear of the driver painted, tinted or constructed in some manner so as to obstruct or obscure the driver's view, provided that the vehicle is equipped with an exterior mirror on each side of the vehicle. If glazing material remains in any of the window openings mentioned above, it must be possible to read the approval markings.

(h) A vehicle shall not be certified which has mirror-type material on any window.

Amended by R.1986 d.166, effective May 5, 1986.
See: 17 N.J.R. 894(a), 18 N.J.R. 995(a).
Substantially amended.

Law Review and Journal Commentaries

Harrison Is Disagreed With; Stop of Vehicle with Tinted Windows Okay. P.R. Chenoweth, 133 N.J.L.J. No. 6, 49 (1993).

Case Notes

State regulations that are virtually identical to federal regulations governing use of tinted windows on motor vehicles are not preempted by federal regulations. *State v. Oberlton*, 262 N.J.Super. 204, 620 A.2d 468 (L.1992).

13:20–33.7 Obstruction to driver's view; Classes I and II licensees

(a) No accessory or other object shall be mounted in such a manner as to interfere with the driver's view.

(b) Signs, posters, stickers or other material, except the inspection sticker, or the special sticker used to identify vehicles of disabled persons, shall not be placed upon the windshield, corner windows or glazing of adjoining windows, or front side windows of any motor vehicle.

(c) A vehicle shall not be certified having an air scoop on the engine hood if the scoop is high enough to obstruct more than a three inch high area of the windshield glass. The height of the obstructed areas of the windshield glass can be measured by placing a straight edge on the top of the scoop and holding the straight edge in a level position with one end contacting the windshield glass.

13:20–33.8 Horn; Classes I and II licensees

(a) Certification shall be refused for the following reasons:

1. A horn not audible under normal conditions at a distance of 200 feet;

2. A vehicle having a horn which emits an unreasonably loud or harsh sound shall not be rejected but the motorist should be advised to have the condition corrected. An unreasonably loud horn, such as an air horn, is permitted on a truck providing the truck is also equipped with a standard horn for use in urban areas;

3. A horn not securely fastened to the vehicle;

4. A horn with a broken button or switch, or a horn not having a button or switch. (Example, grounding a bare wire to activate horn.);

5. A horn with an activating button or switch beyond the reasonable reach of the driver;

6. A horn button located in a hidden or inconspicuous location or a horn button which would require the driver to take his eyes off the road;

7. A horn ring broken so as to be likely to cause injury or to snag clothing;

8. A vehicle equipped with a warning whistle, siren or bell (except an authorized emergency vehicle), although any vehicle may be equipped with a theft alarm warning device which is so arranged that it cannot be used by the driver as an ordinary warning signal.

Note: Certification shall not be refused because of a horn which is only activated by a portion of the de-

signed area of the horn ring (dead spots or spotty) or because of a horn ring or button which would require the steering wheel to be turned before the horn could be sounded. However, the motorist should be advised to have these defects corrected.

13:20–33.9 Windshield wipers; Classes I and II licensees

(a) Every motor vehicle having a windshield shall be equipped with at least one properly operating wiper to provide clear vision to the driver. If a vehicle is equipped with only one windshield wiper, it is required that the device be so located that when operated, it cleans the portion of the windshield directly in front of the driver which is necessary for him to see through in order to properly operate the vehicle.

(b) If a vehicle was originally equipped with two windshield wipers and is less than ten years old, both wipers must operate properly.

(c) The windshield wiper should be capable of operating at a speed necessary to provide the driver a clear view ahead under all conditions of weather.

(d) Windshield wiper blades must not be damaged, hardened, deteriorated, missing or of an improper type (such as a blade designed for a flat windshield installed on a curved windshield) or of improper size.

(e) The windshield wiper blade shall be held against the windshield with adequate pressure to provide the driver a clear view ahead under all conditions of weather.

(f) A windshield wiper shall clean the full area of a windshield for which it was designed.

(g) A windshield wiper control must not be located beyond the reach of the driver and shall be in good working order.

13:20–33.10 Clearance lights; Classes I and II licensees

(a) Clearance lights are lights which show to the front and rear of the vehicle respectively, mounted on the permanent structure of the vehicle as near as practical to the upper left and right extreme edges so as to indicate overall width and height of the vehicle.

(b) Two amber clearance lights are required on the front and two red clearance lights are required on the rear of a vehicle (truck or bus) 80 inches or more in width manufactured after January 1, 1965.

(c) Clearance lights must be of a type approved as meeting the Standards of the Society of Automotive Engineers. The letters "SAE" and the letters "P1" or "P2" or "PC" along with the manufacturer's name or trademark are on the lens of such lights in most cases.

(d) Every clearance light shall be clean and securely mounted in a workmanlike manner on a permanent part of the vehicle.

(e) A combination clearance and side-marker light is a single lamp which fulfills the requirements of both a clearance and a side-marker light.

13:20-33.11 Turn signals (direction signals) and hazard warning signals; Classes I and II licensees

(a) Every motor vehicle except passenger vehicles manufactured before July 2, 1954 shall be equipped with front and rear turn signals. When any vehicle, regardless of the date of its manufacture, is equipped with turn signals, the turn signals must be in proper operating order.

(b) All turn signal and hazard warning signal systems including lamps, flashers and operating units must be of a type approved as meeting the Standards of the Society of Automotive Engineers. The letters "SAE" along with the manufacturer's name and trademark are often on such devices. In the case of front and rear turn signal lights, the letter "I" or the letter "D" is often on the lens.

(c) Front turn and hazard warning signal lights shall be mounted at the same level and as widely spaced laterally as practical. They shall emit a flashing white or amber light, visible for a distance of 500 feet.

(d) Rear turn and hazard warning signal lights shall be mounted at the same level and as widely spaced laterally as practical. They shall emit a flashing amber or red light visible for a distance of 500 feet.

(e) All signal lights must be securely mounted in such a manner so as to reduce the likelihood of their being obscured by mud or dust thrown up by the wheels.

(f) The signal lights shall not be obstructed by any part of the chassis, body or bumper.

(g) Signal lights shall flash from 50 to 130 times per minute. The "on" period of the flashes shall be long enough to permit bulb filaments to reach full brightness.

(h) All signal light systems and components should be in proper operating condition. Certification of a vehicle may not be refused because a turn signal light has a cracked lens, providing no white light shows to the rear and no portion of lens is missing. However, the motorist should be advised to have the defect corrected.

13:20-33.12 Reflectors; Classes I and II licensees

(a) Reflectors are devices used on vehicles to give an indication to an approaching driver by reflective light.

(b) Reflectors must be of a type approved as meeting the Standards of the Society of Automotive Engineers. The letters "SAE" and the letter "A" (for Class A reflectors) or the letter "B" (for Class B reflectors) along with the manufacturer's name or trademark are on such reflectors in most cases.

(c) Passenger cars manufactured before July 2, 1954, must have one Class A or Class B red reflector on the vehicle.

(d) Passenger cars manufactured after July 1, 1954, must have two Class A red or two Class B red reflectors mounted on the rear of the vehicle as far apart as practical.

(e) All passenger cars with commercial registration and all trucks and buses must have two Class A red reflectors mounted on the rear of the vehicle as far apart as practical.

(f) A vehicle (truck or bus) 80 inches or more in width manufactured after January 1, 1965, must have one amber Class A reflector mounted on each side of the vehicle near the front and one red Class A reflector mounted on each side of the vehicle near the rear.

(g) The mounted height of a reflector shall not be less than 12 inches or more than 60 inches from the road surface. Every reflector shall be clean and installed in a workmanlike manner so as to perform its function adequately and to provide maximum stability and minimum likelihood of damage.

(h) Any reflector, otherwise properly mounted, may be securely installed on flexible strapping or belting provided that under conditions of normal operation it reflects light in required direction.

(i) The mounted height of a reflector shall be measured from the center of the reflector to the road surface.

13:20-33.13 Identification lights; Classes I and II licensees

(a) Identification lights are used in groups of three in a horizontal row, which show to the front and rear respectively and have lamp centers spaced not less than 6 inches nor more than 12 inches apart. They must be mounted on the permanent structure as close as practical to the vertical centerline and the top of the vehicle. No part of front identification lights or their mountings may extend below the top of the vehicle windshield.

(b) A vehicle (truck or bus) 80 inches or more in width manufactured after January 1, 1965, must have three amber identification lights on the front of the vehicle and three identification (red) lights on the rear of the vehicle. If the cab is not more than 42 inches wide at the roof line a single identification light at the centerline of the cab will meet the requirements for front identification lights.

(c) Identification lights must be of a type approved as meeting the Standards of the Society of Automotive Engineers. The letters "SAE" and the letters "P" or "P2" along with the manufacturer's name and trademark are on the lens of such lights in most cases.

(d) Every identification light shall be clean and securely mounted in a workmanlike manner on a permanent part of the vehicle.

13:20-33.14 Side-marker lights; Classes I and II licensees

(a) Side-marker lights are lights on the left and right sides near the front and rear of a vehicle that show to the side and are intended to indicate vehicle length.

(b) A vehicle (truck or bus) 80 inches or more in width manufactured after January 1, 1965, must have one amber side-marker light mounted on each side near the front and one red side-marker light mounted on each side near the rear. Side-marker lights must be of a type approved by the Society of Automotive Engineers. The letters "SAE" and the letters "P1" or "P2" or "PC" along with the manufacturer's name or trademark are on the lens of such lights in most cases.

(c) Every side-marker light shall be clean and securely mounted in a workmanlike manner on a permanent part of the vehicle. Side-marker lights may be mounted at optional height on the side of the vehicle.

(d) A combination clearance and side-marker light is a single lamp which fulfills the requirements of both a clearance and side-marker light.

13:20-33.15 Taillights (red rear lights) and plate light; Classes I and II licensees

(a) Every motor vehicle, other than a motorcycle, must have at least two red taillights and at least two red reflectors, one at each side, except that a passenger vehicle manufactured before July 2, 1954, may be equipped with one red taillight and one red reflector. If a vehicle is equipped with two or more taillights on each side, it shall not be refused certification because some of the taillights are not operative, providing one taillight on each side is operative. However, a motorist should be advised to have the defective lights repaired. Certification of a vehicle may not be refused of a taillight having a cracked lens providing no white light shows to the rear; however, the motorist should be advised to have the defect corrected.

(b) Taillights must be of a type approved as meeting the Standards of the Society of Automotive Engineers. The letters "SAE" and the letter "T" along with the manufacturer's name or trademark are often on the lens of such lights.

(c) Taillights shall exhibit a red light visible from a distance of 500 feet to the rear of the vehicle. The lights shall

not be obstructed by any part of the chassis, body or bumper.

(d) Taillights must be clean and securely mounted. The mounted height of taillights (measured from center of lens to road surface) shall not be more than 72 inches nor less than 20 inches. On any vehicle carrying flammable liquids as a cargo, the taillights may be mounted higher than 72 inches. When two taillights are required, they shall be mounted at the same level and spaced as far apart laterally as practical.

(e) Certification of a vehicle may not be refused if the license plate light is inoperative, but rather the motorist advised to have the defect corrected. License plate lights must be of a type approved as meeting the Standards of the Society of Automotive Engineers. The letters "SAE" and the letter "L" along with the manufacturer's name or trademark are often on the lens of such lights.

13:20-33.16 Stoplights; Classes I and II licensees

(a) Every motor vehicle, other than a motorcycle, must be equipped on the rear with at least two stoplights, one at each side, except that a passenger vehicle manufactured before July 2, 1954, may be equipped with one stoplight.

(b) All stoplights must be of a type approved as meeting the Standards of the Society of Automotive Engineers. The letters "SAE" and the letter "S" along with the manufacturer's name or trademark are often on the lens of such lights.

(c) Stoplights shall exhibit a red or amber color visible from a distance of 500 feet to the rear of the vehicle. The lights shall not be obstructed by any part of the chassis, body or bumper.

(d) Stoplights shall be clean and securely mounted. Certification may not be refused because of a stoplight having a cracked lens, providing no white light shows to the rear; however, the motorist should be advised to have the defect corrected. If a vehicle is equipped with two or more stoplights on each side, it shall not be refused certification because some of the stoplights are not operative, providing one stoplight on each side of the vehicle is operative. However, the motorist should be advised to have the defective lights repaired.

13:20-33.17 Wheels; Classes I and II licensees

Wheels must turn freely and the lateral or radial runout of the rim bead shall not exceed the vehicle manufacturer's specifications. Wheels must also be securely mounted and there shall be no visible cracks, elongated bolt holes, broken bolts or other defects.

13:20-33.18 Tires; Classes I and II licensees

(a) The tread on each tire shall not be less than $\frac{7}{32}$ of an inch deep.

(b) Many tires have built-in tread depth indicators that become exposed when tread depth is less than $\frac{2}{32}$ of an inch. Tread depth indicators must be inspected and a tire rejected if it is worn so that the indicators are visible in any two adjacent major grooves at three locations spaced approximately equally around the outside of the tire. For tires without tread depth indicators, it is necessary to measure the tread depth with a tread gauge.

(c) Tires shall be free from chunking, bumps, knots or bulges evidencing cord, ply or tread separation from the casing or other adjacent materials. Tire cords or belting materials should not be exposed.

(d) There shall not be a major mismatch in nominal size, construction or profile between tires on the same axle, or a major deviation from the vehicle manufacturer's tire recommendations. Tires shall not be so wide that they protrude beyond the fenders.

(e) Tires on vehicles registered for use on the public roads shall not be marked "FOR FARM USE ONLY," "OFF HIGHWAY USE ONLY" or "FOR RACING USE ONLY." Tires which can be legally regrooved below the original groove depth must be marked "regroovable."

(f) Studded tires cannot be legally used on a public highway in New Jersey earlier than November 15 or later than April 1 of any winter season. Certification of a vehicle shall not be refused because of improper use of studded tires; however, the driver shall be advised to have the condition corrected.

13:20-33.19 Exhaust system; Classes I and II licensees

(a) The following shall not be certified:

1. A passenger car if it produces excessive exhaust noise ("excessive exhaust noise" is generally defined as more noise than that produced by the usual or normal passenger car);

2. A truck or bus if it produces more exhaust noise than that produced by the usual or normal truck or bus of the same gross vehicle weight;

3. A motor vehicle if there is evidence of exhaust gas leakage at any point in the exhaust system;

4. An exhaust system which has loose or worn components or has been patched. Welding which has been properly done and is in good condition can be certified but other types of patching cannot.

- i. Certification should not be refused because a muffler has drain holes which were obviously placed in it at the time of manufacture for drain purposes.

5. An exhaust system in which all parts are not properly mounted. The entire exhaust system must be in such condition that it cannot burn or cause injury to any person or animal. Exposed exhaust pipes, stacks or other parts of the exhaust system which might burn a person or cause injury must be protected in some manner.

6. A vehicle with any part of the exhaust system passing through the passenger compartment.

Note: The exit point for the exhaust gas shall be located so that dangerous amounts of exhaust gas will not enter the passenger compartment under normal vehicle use even with the windows open or the outside air inlets to the heater or air conditioner open. A replacement exhaust system is acceptable providing it is specifically manufactured for the vehicle by a reputable company which guarantees that the exhaust system has a safe exhaust gas exit location.

13:20-33.20 Definitions; engine emissions terms; Classes I and II licensees

The following words and terms, when used in this Subchapter, shall have the following meanings unless the context clearly indicates otherwise.

"Pollutants" mean carbon monoxide (CO), hydrocarbons (HC) and smoke.

"Test equipment" means the exhaust emission tester shall be of a nondispersive infrared (NDIR) type and approved for use at licensed reinspection centers by D.E.P. The device shall be of a design meeting "Specifications of Exhaust Gas Analytical System" on file with the State Commissioner of Environmental Protection.

"Variance" means certain vehicle classes manufactured prior to 1968 are not able to comply with State emission inspection standards. Department of Environmental Protection (DEP) and Division of Motor Vehicles have exempted the following vehicle classes from vehicle reinspection:

1. All pre-1968 Saab two-stroke vehicles. These vehicles should be maintained, however, at the lowest practical emission levels and should not emit "excessive" smoke.

"Vehicles for reinspection" mean any gasoline-fueled (diesels excluded) light-duty motor vehicles registered at 6,000 pounds gross weight or less. Motorcycles with an engine displacement of less than 50 cubic inches (819.5 cubic centimeters) are not subject to the CO and HC reinspection test. However, motorcycles shall not emit "excessive" exhaust smoke. "Excessive" exhaust smoke, in this case, is generally considered to mean more exhaust smoke than that produced by the usual or normal vehicle of this type.

13:20-33.21 Prescribed vehicle emission reinspection test procedure; Classes I and II licensees

(a) The prescribed vehicle emission reinspection test procedure is:

1. Step 1: The reinspection test shall be conducted after the engine has been operating for a sufficient period of time to attain normal operating temperature.
2. Step 2: With motor vehicle in neutral gear, all accessories off, hand brake secured, accelerate engine to approximately 2500 r.p.m. and hold. Observe for visible smoke in the exhaust emissions and/or crankcase emissions.
3. Step 3: Any motor vehicle designed primarily for transportation of persons or property and registered at 6,000 pounds gross weight or less shall not emit visible smoke in the exhaust emissions or in the crankcase emissions.
4. Step 4: With the engine operating at idle, insert the sample probe of the exhaust tester into the engine exhaust pipe. The probe tip shall be inserted at least six inches into the tailpipe. For dual exhaust vehicles check both exhaust pipes; the higher reading shall be the exhaust gas measurement.
5. Step 5: The steady state emission levels measured as percent carbon monoxide (CO%) and parts per million of hydrocarbons (HC ppm) in the exhaust shall be the inspection test result. These results shall be compared by vehicle model year and effective date as shown in Table 1.

TABLE 1
Exhaust Emission Standards For Vehicles Subject to Inspection by the Division of Motor Vehicles and/or Licensed Reinspection Centers

Model Year of Vehicle	Effective Aug. 1, 1975		Effective Feb. 1, 1976	
	CO(%)	HC(PPM)	CO(%)	HC(PPM)
Pre-1968: All Vehicles	8.5	1400	7.5	1200
1968-1969: All Vehicles	7.0	700	5.0	600
1970-1974: All Vehicles	5.0	500	4.0	400
1975-1976: All Vehicles	3.0	300	2.0	200

Important Note: The above standards are New Jersey inspection standards only, not vehicle performance of manufacturers' recommended standards. Service mechanics should maintain vehicles for inspection or sale so that exhaust emission levels are in accordance with specifications recommended by the manufacturer or seek reasonable emission levels as shown below in Table 2, but never in excess of the State standards in Table 1.

TABLE 2
Reasonable emission levels should be less than:

	CO%	Tolerance	HC(ppm)	Tolerance*
Pre-1968 G.M. Motor Vehicles	3.0	± 2.0	700	± 200
Pre-1968 Non-G.M. Motor Vehicles	3.0	± 2.0	500	± 200
1968-1969 All Vehicles	3.0	± 2.0	300	± 100
1970-1974 All Vehicles	1.5	± 1.0	200	± 100
1975-1976 (Catalytic equipped)	0.5	± 0.5	50	± 25
1975-1976 (Non-catalytic)	1.0	± 0.5	100	± 50

* The reasonable HC emission levels can be achieved by most vehicles. However, some low production vehicles may have reasonable HC emission levels at or above these levels.

13:20-33.22 Equipment calibration; Classes I and II licensees

(a) The exhaust gas analyzer shall be used and maintained in accordance with manufacturers' instructions and recommendations of the Department of Environmental Protection. For every vehicle reinspection these instructions shall include:

1. Equipment shall be warmed up before every vehicle reinspection.
2. Zero and span shall be checked and corrected before every vehicle reinspection.

(b) The Division of Motor Vehicles (DMV) in cooperation with the DEP, will check each center's analyzers' calibration and review the center's pre-test procedure periodically. If the center's equipment is unable to be calibrated within design specifications, the DMV field investigator shall designate the equipment "out of service" and thus, the center shall not perform emission reinspections until proper notification of correction is provided by the center's calibration and repair representative unless the center complies with the provisions of N.J.A.C. 13:20-32.3.

As amended, R.1978 d.67, effective February 22, 1978.
See: 10 N.J.R. 17(a), 10 N.J.R. 122(b).

13:20-33.23 Engine repairs and diagnosis; Classes I and II licensees

(a) The exhaust emission analytical equipment should be used to diagnose vehicle malfunctions. Such diagnostic procedures, use and care of test equipment, individual vehicle idle specifications and maintenance items are contained in a manual published by the DEP, entitled, "Auto Emission Control Manual." Copies may be obtained by contacting the Department of Environmental Protection, Bureau of Air Pollution Control, Mobile Source Section, Box 2807, John Fitch Plaza, Trenton, New Jersey 08625; Telephone (609) 292-6714-15.

(b) Courses in auto emission control will be offered periodically. Operators of licensed reinspection centers will be notified as to time and place and encouraged to attend.

(c) Display window "Approved Emission Test Center" posters are available by contacting the above address or telephone number.

(d) If a specific vehicle is unable to be corrected and/or if guidance is required to perform the emissions test, the center may contact DEP's Motor Vehicle Emission Laboratory, 380 Scotch Road, West Trenton 08628: Telephone (609) 292-7638-39 for help.

13:20-33.24 Headlights; Classes I and II licensees

(a) Headlights shall be inspected for aim according to the specifications shown below. (Headlights which are aimed to the Society of Automotive Engineer's recommendations will meet the specifications and, therefore, are also acceptable.):

1. High beam aim specifications:

i. Vertical aim: From four inches above to five inches below;

ii. Horizontal aim: From six inches right to six inches left.

2. Low beam aim specifications:

i. Vertical aim: From three inches below to 14 inches below;

ii. Horizontal aim: From eight inches right to 23 inches right.

(b) It should be noted that the specifications shown above refer to the location of the "hot spot" (center of the high intensity portion of the beam pattern) based on a 25-foot distance from the test screen. The vertical aim specifications show the distance the "hot spot" shall be above or below the horizontal centerline straight ahead of the headlight center. The horizontal aim specifications shows the distance the "hot spot" shall be to the right or to the left of the vertical centerline straight ahead of the headlight center.

(c) SAE visual inspection limits for the vertical aim of the "hot spot" of Type 1 units are from four inches above to 4 inches below, and the limits for horizontal aim are from four inches right to 4 inches left.

(d) SAE visual inspection limits for top edge of high intensity zone of Type 2 units are from four inches above to four inches below, and for left edge are from four inches left to four inches right.

(e) If headlight aim is inspected with a mechanical aimer, the inspection limits for both Type 1 and Type 2 units shall be four inches above to four inches below and four inches left to four inches right.

(f) Headlights shall be properly installed so that their beams are readily adjustable, both vertically and horizontally, and their aim is not disturbed by ordinary vehicle operation.

(g) Headlights must be of a type approved as meeting the Standards of the Society of Automotive Engineers. Headlights on all 1940 and later model vehicles must be of the sealed beam type.

(h) A vehicle having a headlight with a cracked, broken or missing lens shall not be certified.

(i) There shall be no auxiliary equipment, such as colored spray on the lens, visor, reflector or other attachment which is not included in the Society of Automotive Engineers Standards.

(j) On vehicles equipped with four headlights, the Type 2 light must be mounted above or to the outside of the Type 1 light. A vehicle having recessed headlights shall have nothing covering them or in front of them when lighted except clear glass. A 1969 or later model vehicle equipped with headlights which, when in use, have any styling or other features, such as a glass cover or grille in front of the lens, shall not be certified.

(k) On motor vehicles having retractable headlights, there is a tell-tale light on the instrument panel to notify the driver that the headlights are turned on, but not completely open. This tell-tale light must be in proper operating condition so that it is on when the headlights are not fully open.

(l) Retractable headlights must be in the fully open position when when the headlight aim is inspected.

(m) Vehicles which are used for plowing snow may have an extra set of headlights mounted above the plow. Switching shall be provided so that either set of headlights may be used, but not both.

(n) Certification of a vehicle shall not be refused because the beam indicator light does not operate properly, but motorists should be advised to have the defect corrected.

(o) A vehicle should not be refused certification because of a missing headlight rim or rims, but the motorist should be advised to have the rim or rims replaced so as to provide proper protection to the adjusting mechanism and other parts.

13:20-33.25 Rear view mirrors; Classes I and II licensees

(a) A vehicle may not be certified if it does not have at least one rear view mirror. A passenger automobile manufactured after January 1, 1965 must have an interior mirror and an exterior mirror on the driver's side.

(b) A commercial motor vehicle manufactured after January 1, 1965 must have an interior mirror and an exterior mirror on the driver's side, except that every such vehicle so constructed or loaded as to obstruct or obscure a rear view from an interior mirror shall, in lieu of an interior mirror, be equipped with an exterior mirror on the side of the vehicle opposite the driver's side.

(c) Mirrors shall be securely mounted and located and adjusted so as to give the driver adequate rear view vision. Mirrors must not cause unsafe interference with the driver's forward vision.

(d) A vehicle may not be certified if a mirror is discolored, peeled, tarnished, cracked, broken or has sharp edges.

13:20-33.26 Miscellaneous lights; Classes I and II licensees

(a) All lights used on motor vehicles must be of a type approved as meeting the Standards of the Society of Automotive Engineers. The letters "SAE" along with the manufacturer's name or trademark are often on the lens of such lights. In addition, the letters listed below also often appear on the following lights:

1. Fog lights = F;
2. Spot lights = O;
3. Emergency warning lights = W or W1 or W3;
4. Supplemental driving or passing lights = Y or Z.

(b) Any motor vehicle may be equipped with not to exceed two auxiliary lamps mounted on the front of the vehicle at a height not less than 12 inches nor more than 42 inches above the level surface upon which the vehicle stands. Auxiliary lamps include but are not limited to fog lamps, passing lamps and supplementary driving lamps. Auxiliary lamps shall be aimed in conformance with the SAE Standards applicable to the particular type of auxiliary lamp. Auxiliary lamps shall be of a type approved by the Director.

1. Fog lamps are lamps which may be used with or in lieu of the lower beam headlights to provide illumination under conditions of rain, snow, dust or fog. The color of the light from a fog lamp shall be white or yellow (amber). Approved lamps shall meet the requirements of SAE J-583d. It is recommended that fog lamps be used in conjunction with the low beam headlights.

2. Passing lamps are also known as auxiliary low beam lamps and are designed to supplement the lower beam of a standard headlamp system. Approved lamps shall meet the requirements of SAE J-582a. Passing lamps shall be wired so that they may be controlled by a switch separate from the headlamp switch. They must also be operated only in conjunction with the lower beam of the headlamp system.

3. Supplementary driving lamps are an auxiliary lamp which may be used to supplement the upper beam of a standard headlamp system. Approved lamps shall conform to the requirements of SAE J-581. Supplementary driving lamps shall be wired so that they may be controlled by a switch separate from the headlamp switch. They must also be operated only in conjunction with the upper beam of the headlamp system.

(c) A spot light is a light which can be aimed at will. Any motor vehicle may be equipped with not more than one spot light, but the use of any such spot light for driving purposes is prohibited. Spot lights shall be of a type

approved by the Director. Approved spot lights shall meet the requirements of SAE J-591b.

(d) Any motor vehicle may be equipped with not more than two side cowl or fender lights which shall emit a white or yellow light without glare.

(e) Any motor vehicle may be equipped with not more than one running board courtesy light on each side thereof which shall emit a white or yellow light without glare.

(f) Any motor vehicle may be equipped with one or more backup lights either separately or in combination with other lights. No backup light shall be continuously lighted when the motor vehicle is in forward motion.

(g) On vehicles used for plowing snow, there may be auxiliary lights connected to either the parking light system or the low beam headlight system. If sealed beam headlight units are used for the auxiliary lights, they must be wired so that the taillights will be illuminated when the auxiliary lights are turned on but the regular headlights will not be illuminated. Auxiliary turn signal lights are also permitted on these vehicles.

(h) Flashing lights are prohibited on motor vehicles except as a means for indicating a right or left turn or for hazard warning signals or for authorized emergency vehicles (vehicles of a fire department, police vehicles and other vehicles having special permits for flashing emergency warning lights). It is legal to provide means to flash headlights and/or side-marker lights for signaling purposes.

(i) A vehicle owned by an active member in good standing of a recognized volunteer fire company may be equipped with one flashing (or non-flashing) special blue light not more than 7½ inches in diameter or more than 21 candle power. The special light shall be installed on the front of the vehicle so that the top of the special light is no higher than the top of the vehicle headlights and shall be controlled by a switch installed inside the vehicle.

(j) A vehicle owned by an active member in good standing of a first aid squad affiliated with the New Jersey First Aid Council may have a special non-flashing white light not exceeding 21 candle power with a lens not more than four inches in diameter and having an illuminated gold cross on a white background. The light must be mounted on the exterior of the vehicle so that it will not be greater height from the ground than the headlights.

(k) All miscellaneous lights must be clean and as far as practical they shall be securely mounted in such a manner as to reduce the likelihood of their being obscured by mud and dirt thrown up by the wheels.

(l) Two or more lighting devices and reflectors may be combined optically, but the following combinations are prohibited:

1. A turn signal with a headlight;
2. A clearance light with a taillight or identification light.

(m) There are other motor vehicle lights which are not covered in this manual. The manufacturer's name or trademark and the letters "SAE" often appear on the lens of such lights along with the identification letters shown below:

1. E: Side turn signal lamps (mounted on vehicle sides);
2. K: Cornering lamps;
3. M: Motorcycle and motor driven cycle headlamps—motorcycle type;
4. N: Motorcycle and motor driven cycle headlamps—motor driven cycle type;
5. R: Back-up lamps;
6. U: Supplemental high mounted stop and turn signal lamps;
7. V: Liquid burning emergency flares;
8. W4: Emergency reflex reflectors;
9. X: Emergency lanterns.

As amended, R.1979 d.193, eff. May 14, 1979.
See: 11 N.J.R. 199(a), 11 N.J.R. 298(c).

13:20-33.27 Wiring and switching; Classes I and II licensees

(a) A vehicle may not be certified for the following reasons:

1. Wiring in poor condition, improperly installed or so located as to cause damage.
2. Any connection that is not secure or shows signs of excessive corrosion.
3. Switches not in good condition and not functioning properly.
4. Any lamp circuit that does not light the proper filament when the appropriate switch position is applied.
5. Any defects in wiring or switching which would be likely to adversely affect the lighting performance.

13:20-33.28 Headlight beam indicator lights; Classes I and II licensees

Certification of a vehicle may not be refused because the headlight beam indicator light does not operate properly; however, the motorist should be advised to have the defect corrected.

13:20-33.29 Turn signal and hazard warning signal indicator lights; Classes I and II licensees

(a) Certification of a vehicle may not be refused because of an inoperative turn signal indicator light and/or an inoperative hazard warning signal indicator light; however, the motorist should be advised to have the defect corrected.

(b) If any turn signal light is not readily visible to the driver, there should be an illuminated indicator to give the driver a clear and unmistakable indication that the turn signal system is turned "on".

(c) In vehicles equipped with a single turn signal indicator, a separate hazard warning signal indicator should flash and the turn signal indicator may flash while the hazard warning signal system is turned "on".

(d) In vehicles equipped with right and left turn signal indicators, both indicators or separate indicators should flash simultaneously while the hazard warning signal system is turned "on".

(e) If a separate indicator light is used for the hazard warning signal system it should emit a red color and have a minimum area equivalent to a 0.5 inch diameter circle.

13:20-33.30 Antenna; Classes I and II licensees

Any antenna mounted on a motor vehicle shall be securely attached so as not to swing or project in a hazardous manner. Certification may not be refused because of an insecure radio antenna; however, the motorist should be advised to have the condition corrected.

13:20-33.31 Body; Classes I and II licensees

The body panels, floor pan and other sections shall be in good condition, not rusted out or missing so as to allow exhaust gasses to enter the passenger compartment. Body must be free of rips and sharp edges which could cause injury.

13:20-33.32 Bumpers; Classes I and II licensees

Bumpers must be securely mounted and in good condition with no sharp or protruding parts of edges which could cause injury. Front and rear bumper heights must be in accordance with vehicle manufacturer's specifications.

13:20-33.33 Doors; Classes I and II licensees

(a) Doors shall be in proper operating condition and all operating devices, handles, buttons, hinges and latches, shall be in good working order. A method of opening the door from the outside is not required on vehicles with fabric tops and equipped with glazing material which can be readily removed without the use of tools.

(b) Vehicles designed and manufactured with doors must be equipped with doors.

(c) Vehicles designed and manufactured without doors must have seat belts or a strap, chain, or restraining device of some type, across the opening.

13:20–33.34 Fenders and fender flaps; Classes I and II licensees

(a) Fenders must be securely mounted and have no rips or sharp edges which could cause injuries to persons.

(b) Fenders must cover the width of the tire. Rear fenders must extend down far enough to prevent the wheels from throwing dirt, water or other material onto the windshields of vehicles following. Fender flaps may be attached to the rear fenders to provide the required length.

(c) Movable type fenders are approved for use on motorcycles (two or three wheel motor vehicles) providing they are properly mounted and give adequate coverage but they are not approved for motor vehicles having more than three wheels.

13:20–33.35 Fuel system; Classes I and II licensees

Fuel leakage at any point in the system is cause for rejection. Fuel tank and piping must be securely mounted and fuel tank properly capped.

13:20–33.36 Hood; Classes I and II licensees

Vehicles shall be equipped with an engine hood. Hood must be properly secured and latched, and all hinges, latches and other components must be in good working order.

13:20–33.37 Lettering; Classes I and II licensees

Vehicles with commercial plates shall have conspicuously displayed on the vehicle or on a name plate attached to the vehicle, the name of the owner, lessee or lessor of the vehicle, and the name of the municipality in which the owner, lessee or lessor resides. The sign on the name plate shall be in plain view and the lettering shall be as close as possible to three inches high. A commercial vehicle may be registered under Code 15 as a “non-commercial” vehicle and passenger plates will be issued. However, a vehicle of this type must not have any advertising, signs, letters, names or addresses on its exterior excepting trademarks and labels of the manufacturer and dealer. Do not refuse to certify a commercial vehicle with commercial plates that does not display the owner’s name and address and do not refuse to certify a “non-commercial” vehicle which displays any type of lettering but advise the motorist to have the condition corrected.

13:20–33.38 Ornaments; Classes I and II licensees

All ornaments shall be free of sharp parts or edges which could injure persons.

13:20–33.39 Pedals; Classes I and II licensees

Brake and clutch pedals must have rubber pads or some other method of providing the pedals with a non-skid surface. The accelerator pedal must also be in proper operating condition.

13:20–33.40 Racks or carriers; Classes I and II licensees

Racks or carriers are approved without a special permit on a motor vehicle providing the maximum legal vehicle registration limits are not exceeded (eight feet in width; 13 feet in height) and providing they cannot be considered to be “dangerous projections” which could cause injury to pedestrians, cyclists or other persons.

13:20–33.41 Reflective tape; Classes I and II licensees

Reflective tape of a color amber to white may be displayed on the front of a motor vehicle. Reflective tape of a color amber to red may be displayed on the rear of a motor vehicle.

13:20–33.42 Seats; Classes I and II licensees

All seats must be securely mounted and free of hazardous conditions. The driver’s seat must lock securely in the desired position.

13:20–33.43 Seat belts; Classes I and II licensees

(a) All passenger automobiles manufactured after July 1, 1966, must be equipped with at least two sets of seat safety belts for the front seat of the automobile and the anchorage units necessary for their attachment or equipped with some other suitable restraining device.

(b) Seat belts and anchorage units or such restraining device shall be of a type approved as meeting Federal standards of Standards of the Society of Automotive Engineers. Such belts and anchorage units can be identified by the labels or marking on them. The buckles and anchorage units must be in good condition and the webbing shall not be dangerously worn or cut.

13:20–33.44 Shift indicator; Classes I and II licensees

Vehicles equipped with automatic transmission shall be equipped with indicators in proper working order. Minor misalignment (not over one half the distance between shift positions) of a gear shift indicator is acceptable but the motorist should be advised to have the condition corrected.

13:20–33.45 Transmission; Classes I and II licensees

The transmission of a motor vehicle must operate properly and be capable of operating in reverse.

13:20–33.46 Television; Classes I and II licensees

A motor vehicle shall not have a television installed in such a manner that the viewing screen is visible to the driver while operating the vehicle.

13:20-33.47 Trunk lid; Classes I and II licensees

The trunk lid should be capable of being securely fastened. If this cannot be done, certification of the vehicle may not be refused; however, the motorist should be advised to have the defect corrected.

13:20-33.48 Service brakes (including equalization and pedal reserve); Classes I and II licensees

(a) The inspection for service brake pedal reserve shall be made as follows. (Pedal reserve is the amount of total pedal travel left in reserve when the pedal is depressed to the brake applied position.)

(b) With the vehicle stationary and the service brake pedal depressed under a moderate foot force (25 pounds for power brakes and 50 pounds for other brakes) there must be a minimum of one third of the total average pedal travel (vehicle manufacturer's specifications) remaining. The engine must be running when power brakes are checked. If there is any question about pedal reserve on a vehicle equipped with disc brakes the pedal reserve should be checked when the brakes are applied while the vehicle is being driven.

(c) With the service brake pedal depressed to the brake applied position for ten seconds under a foot force of approximately 125 pounds there shall be no perceptible decrease in pedal height and no illumination of the brake system failure indicator lamp (if the vehicle is equipped with such a lamp the inspection must be certain that the lamp is in operable condition).

(d) Brake hoses shall not be mounted so as to contact the vehicle body or chassis. Brake hoses shall not be cracked, chafed or flattened. (Protective devices, such as "rub rings" are not to be considered part of the brake hose.)

(e) Hydraulic brake line tubing shall be especially designed for automotive hydraulic brake line use. Tubing designed for gasoline or oil lines is not satisfactory for use on hydraulic brake lines.

(f) If the inspection card shows that the vehicle was rejected for # 22 (service brake) or # 24 (brake equalization) at least one front wheel shall be removed so the inspector can make certain that the internal parts of the brake are in satisfactory condition. Any dangerous wear, breakage or malfunctioning of the brake system is cause for rejection.

(g) The inspector shall also measure brake drum diameter or disc brake rotor thickness.

(h) If the drum is embossed with a maximum safe diameter dimension or the rotor is embossed with a minimum safety thickness dimension, the drum or disc shall be within the appropriate specifications. These dimensions will be found on motor vehicles manufactured since January 1, 1971 and may be found on vehicles manufactured for several years prior to that time. If the drums and discs are not embossed, the drums and discs shall be within the manufacturer's specifications.

(i) Examine brake lining or pad visually and measure height of rubbing surface of lining or pad over rivet heads. Measure bonded lining or bonded pad thickness over shoe surface at the thinnest point of the lining or pad.

(j) On each brake the thickness of a riveted lining or pad shall not be less than one thirty-second of an inch over the rivet heads. The thickness of a bonded lining or pad shall not be less than one thirty-second of an inch over the brake shoe or shoe plate. Brake linings and pads shall not have cracks or breaks that extend to rivet holes except minor cracks that do not impair attachment. Drum brake linings shall be securely attached to brake shoe. Disc brake pads shall be securely attached to shoe plates.

(k) Backing plates and caliper assemblies shall not be deformed or cracked. Brake system parts shall not be broken, misaligned, missing, binding or show evidence of severe wear. Automatic adjusters and other parts shall be assembled and installed correctly.

(l) With engine running, examine vacuum brake hoses visually and aurally. Hoses shall not be collapsed, abraded, broken, improperly mounted or audibly leaking.

(m) Stop engine and apply service brakes several times to destroy vacuum in system. Depress brake pedal with 25 pounds of force and while maintaining that force, start engine. Brake pedal shall fall slightly under force when the engine starts. This test is not applicable to vehicles equipped with full power (central hydraulic) brake systems as the service brake performance test shall be considered adequate test of system performance on such vehicles.

(n) After insuring that the tires are properly inflated conduct either a Type 1 or Type 2 brake performance test as follows:

1. Type 1: If the brakes are tested on a drive-on platform or roller-type brake tester the results must show some brake force produced by each wheel brake and the total brake force must be equal to at least 43.5 per cent of the gross vehicle weight. (This is equivalent to a deceleration of 14 feet per second which would produce a stop from 20 MPH in 30 feet.) The braking force on a front wheel or on a rear wheel shall not be less than 65 per cent of the braking force developed on the other front wheel or rear wheel respectively.

2. Type 2: If a platform or roller type brake tester is not available, the brakes must be road tested on a level, dry, smooth, hard surface that is free from loose material, oil or grease to make sure the vehicle can stop from 20 M.P.H. in 30 feet or less without swerving out of a 12-foot-wide lane.

13:20-33.49 Parking brake; Classes I and II licensees

(a) The parking brake shall be able to hold the vehicle stationary on any up or downgrade upon which it can be operated whether the vehicle is empty or loaded.

(b) The parking brake must be equipped with a ratchet and pawl, or other type of automatic locking device which will hold the brake in the applied position. On vehicles equipped with automatic transmissions and an automatic parking brake release the locking device must hold the parking brake in the applied position regardless of whether the transmission shift lever is in the "neutral" or "parked" position.

(c) When the parking brake is applied there must be a minimum of one third of the total average travel (vehicle manufacturer's specifications) remaining. On certain vehicles the parking brake reserve is checked on the second application of the parking brake lever.

TABLE A
AVERAGE LENGTH OF TIME REQUIRED
TO REINSPECT A SPECIFIC ITEM ON A
PASSENGER CAR, TRUCK OR BUS

Rejection Item Number as Shown on Inspection Card	Item Reinspected	Time Required
3	Steering and Suspension	.3 Hour
5	Parking Lights (Front)	.1 Hour*
6	Glazing	.2 Hour
7	Obstruction to Driver's View and Illegal Sticker	.1 Hour*
8	Horn	.1 Hour*
9	Windshield Wipers	.2 Hour
10	Direction (Turn) Signals, Hazard Warning Lights	.2 Hour
11	Side-Marker, Clearance, Identification Lights, Reflectors	.2 Hour
12	Red Rear (Taillight) Plate Light	.1 Hour*
13	Stop Lights	.1 Hour*
14	Wheels, Tires	.2 Hour
15	Exhaust System	.2 Hour
15A	Engine Emissions (CO), (HC), (SMOKE)	.3 Hour
16	Head Lights	.3 Hour
17	Mirrors (Rear View)	.1 Hour*
18	Miscellaneous Lights	.2 Hour
19	Wiring, Switching	.2 Hour
21	Miscellaneous Items	.3 Hour
22	Service Brakes	.3 Hour
		(For either 22 or 24 on inspection card or both)
23	Parking Brake and Reserve	.2 Hour
24	Service Brakes (Equalization)	.3 Hour
		(For either 22 or 24 on inspection card or both)
25	Service Brakes (Pedal Reserve)	.2 Hour

* Note: If this is the only item to be reinspected on a vehicle the reinspection time shall be considered to be .2 hour.

Editor's Note: In addition to the above text, there are a Division of Motor Vehicles Inspection Card, Instructions Covering Transferred Registrations Expiring Within Three Months, and Instructions Covering Registration Expiring Within Six Months, forms adopted and filed with these rules, but which are not reproduced herein. Further information regarding these forms may be obtained from the Division of Motor Vehicles, 25 South Montgomery Street, Trenton, New Jersey 08625.

13:20-33.50 General information; Class III licensees

(a) This manual contains information concerning the standards and inspection procedures to be used by Class III licensed motorcycle reinspection centers when certifying motorcycles (any two or three wheel motor vehicles) which have been repaired after being rejected at a State inspection station.

(b) A separate manual is available for use by Class I and Class II licensed reinspection centers when certifying passenger cars, trucks and buses which have been repaired after being rejected at a State inspection station.

(c) A reinspection center license authorizes placement of a reinspection approval sticker on a motorcycle as certification that the defects for which the motorcycle was rejected at a State inspection station have been repaired, adjusted or corrected. When such repairs, adjustments or corrections are made, the condition of the rejected items must be brought to the standards described in this manual. Licensed reinspection centers are required to make the checks, tests or inspections as part of the repair job—which is standard automotive repair practice. Centers may charge the motorcycle owner a fee of not more than \$1.50 for the certification (placing the sticker on the motorcycle). However, other charges may not be made except for parts and labor related to the actual repair job.

(d) A reinspection center license also requires reinspection and certification of a motorcycle when the owner himself has made the repairs, adjustments or corrections. In such cases, the center must actually reinspect the rejected defects to determine if they have been brought to the standards described in this manual. A fee for that reinspection service may be charged based on the center's established hourly labor charge for repair service—but only that portion of an hour which the Division has established to be the average time for reinspection of specific rejected items shown in Table 3 at the end of this manual.

(e) If the repairs are made in a center, each mechanic who repaired a specific rejected item must sign his name on the State inspection card next to the applicable rejection category. If the repairs were made by the motorcycle owner or "farmed out" under a reinspection center license, each mechanic who reinspected the rejected items must sign his name on the reverse side of the card at the bottom.

(f) When a reinspection approval sticker is placed on the motorcycle, the center must also stamp the vehicle registration certificate on the reverse side with the imprint shown below:

NEW JERSEY
DIVISION OF MOTOR VEHICLES
REINSPECTION CENTER

LICENSE NO.

STICKER NO.

DATE

(g) The reinspection center license number, the reinspection approval sticker number and the date must be inserted in the imprint. Each center is required to purchase the stamp from commercial sources and the center's license number should be made part of the stamp.

(h) A licensed reinspection center may not accept a motorcycle for certification unless the motorcyclist provides you with the inspection card (readable) used at the inspection station when the motorcycle was inspected and rejected. If the motorcyclist has lost the inspection card, the motorcycle must be returned to the State inspection station and go through the inspection lane again. A sample of the inspection card form VI-1A is reproduced following Table 3 at the end of this manual.

(i) If the defective items have been corrected so as to meet the standards shown in this manual, the motorcycle may be certified by placing an approval sticker on the left lower front fork leg in such a position as to be easily visible for enforcement purposes. The sticker shall be placed in an upright position. In case the construction makes it impossible to place the sticker in the above specified location it shall be placed as close as possible to this position so that it will be visible from the left side of the motorcycle. If there is a previous approval sticker on the left front fork leg, the new approval sticker should be placed on top of the previous sticker. (Rejection stickers are not used for motorcycles.) The inspection card and the motorcycle registration certificate should then be stamped with the reinspection center approval stamp.

(j) If the defective items have not been corrected, enter the "reexamination date" on the inspection card and return it to the motorcyclist.

(k) An inspection card may be marked "MUST BE REINSPECTED AT A STATE INSPECTION STATION." When an inspection card is marked in this manner licensed reinspection center may not certify the motorcycle but it must be returned to a State inspection station.

(l) The owner of a motorcycle rejected at a State inspection station because of a safety defect is required to have the vehicle repaired within 30 days in order to legally operate it in New Jersey.

(m) If a motorcycle is presented at a licensed reinspection center after the 30-day period has expired, the licensed reinspection center may reinspect the vehicle and certify it if the rejected items have been corrected provided a period of not more than 40 days has elapsed since the vehicle was rejected at a State inspection station. If more than 40 days have elapsed the motorcycle must be returned to a State inspection station for a complete reinspection. The motorcyclist may obtain a letter signed by the Director of the Division of Motor Vehicles granting the motorcyclist an extended period in which the vehicle may be legally operated before being subject to reinspection. In order to obtain such letter, the motorcyclist must write to the Bureau of Vehicle Inspection, New Jersey Division of Motor Vehicles, 25 South Montgomery Street, Trenton, New Jersey 08666 or telephone 609-292-4873.

(n) Class III licensed reinspection centers shall be required to conduct initial motorcycle inspections for a period of three years ending May 31, 1986, pursuant to the regulations and procedures for conducting reinspections.

(o) A fee which an authorized reinspection center may charge for an initial inspection shall not exceed one quarter ($\frac{1}{4}$) of the reinspection center's hourly labor charge. The maximum fee for an initial inspection shall be posted on a prominent place on the premises. A copy of the fee shall also be sent to the Licensing Section of the Vehicle Inspection Bureau.

(p) Charges for initial inspections, reinspections and repairs shall be separately stated.

(q) No reinspection center shall require as a condition of performing the initial inspection, that any repairs or adjustments be done by the person, or at the facility of the person performing the inspection.

(r) No service or adjustment shall be performed on the motorcycle at the same licensed reinspection center where the motorcycle was inspected unless the customer signs a written acknowledgment and waiver that he understands his right to have service and adjustments done elsewhere and expressly waives his rights.

As amended, R.1983 d.547, effective November 7, 1983.

See: 15 N.J.R. 1963(a).

Originally filed as an emergency adoption (R.1983 d.547) on November 7, 1983.

In (c), increased fee from \$1.00 to \$1.50. Added new (n) through (r).

As amended, R.1984 d.10, effective January 9, 1984.

See: 15 N.J.R. 1963(a), 16 N.J.R. 247(c).

Section substantially amended.

Amended by R.1985 d.20, effective February 4, 1985.

See: 16 N.J.R. 3288(a), 17 N.J.R. 313(a).

(n): Deleted "12 months" and substituted "three years"; changed date from July 1, 1984" to "May 31, 1986".

13:20-33.51 Credentials; Class III licensees

The driver shall present a valid motorcycle operator's license, a valid New Jersey motorcycle registration certificate, and an insurance identification card for the motorcycle. Photocopies are not acceptable. All forms of credentials must be legible and not altered.

As amended, R.1983 d.547, effective November 7, 1983.

See: 15 N.J.R. 1963(a).

Originally filed as an emergency adoption (R.1983 d.547) on November 7, 1983.

Deleted old and added new text.

As amended, R.1984 d.10, effective January 9, 1984.

See: 15 N.J.R. 1963(a), 16 N.J.R. 247(c).

Section substantially amended.

13:20-33.52 License plate (identification mark); Class III licensees

(a) Certification of a motorcycle shall not be refused because the following requirements are not met, but rather the motorcyclist advised to have the condition corrected.

1. Only a rear plate is required on a motorcycle. The license plate should be clear and distinct and free from grease, dirt or other blurring material so that it is plainly visible at all times of the day and night.

2. License plate must be securely attached to the motorcycle.

3. License plate should be located not less than 12 inches nor more than 48 inches from the ground in a horizontal position, right side up and right side out.

4. The letters and numbers on the license plate shall agree with the letters and numbers on the registration certificate of the motorcycle.

5. The face area of license plate must not be covered by glass, plastic, or similar material.

6. License plate should not be bent or defaced. However, if the letters and/or numerals are totally illegible, the motorcycle must not be certified.

13:20-33.53 Steering, handlebars and suspension; Class III licensees

(a) Certification of a motorcycle shall be refused for any of the following reasons:

1. Frame is bent or damaged so as to constitute a hazard in proper operation of the vehicle.

2. Defective wheels or rims or wheels out of line so that steering and control is affected.

3. Steering-head bearing is loose, broken, defective or out of adjustment.

4. Handles are loose, bent, broken or damaged so as to affect proper steering.

5. Handlebar grips (in normal driving position) are higher than the height of the operator when seated. Inasmuch as no portion of the handlebar grips shall be higher than the shoulder height of the operator, the measurement should be made to the highest point on the handlebar grips.

6. Any components which are defective, broken, loose, missing, unsafe or do not function properly.

7. Steering or suspension system not in a condition equivalent to the motorcycle manufacturer's specifications.

As amended, R.1981 d.16, effective January 16, 1981.

See: 12 N.J.R. 606(c), 13 N.J.R. 149(c).

(a)5 amended.

13:20-33.54 Windscreen, glazing and obstruction to vision; Class III licensees

(a) Windscreen is not required if operator has approved type goggles or approved type face shield. If motorcycle is equipped with a windscreen it should be inspected and

certification refused if any of the following conditions are present:

1. Windscreen is not of an approved type. Windscreen must be approved as meeting Standard Z26.1 of the American National Standards Institute. The letters "AS" along with the trademark of the manufacturer or distributor appear on approved type windscreen.

2. Windscreen support or some other component, obstructs the driver's vision or constitutes a possible injury-producing hazard.

3. Windscreen is dirty, cracked, discolored or scratched so as to obstruct driver's vision.

4. Windscreen is not securely mounted.

5. Sticker or sign on windscreen so as to obstruct driver's vision. In most cases a motorcycle operator looks over the top of a windscreen although there are some three-wheel motorcycles which have an enclosed cab and in these cases, it is important to have no obstruction to the driver's vision.

13:20-33.55 Horn; Class III licensees

(a) Certification of a motorcycle shall be refused for the following reasons:

1. Motorcycle is not equipped with a horn.

2. Horn not securely fastened to motorcycle.

3. Horn button placed in an unsafe position.

4. Horn button not operating properly.

5. Horn wiring in unsafe condition.

6. Horn not audible under normal conditions for at least 200 feet.

7. Motorcycle is equipped with a siren, bell or whistle (except as authorized emergency motorcycle). Any motorcycle may be equipped with a theft alarm warning device which is so arranged that it cannot be used by the driver as an ordinary warning signal.

(b) Certification of a motorcycle may not be refused because of a horn which emits an excessively loud or harsh sound, but rather the motorcyclist advised to have the condition corrected.

13:20-33.56 Windshield wipers; Class III licensees

(a) Some three-wheel motorcycles are equipped with a passenger-car-type windshield. In such cases, the windshield shall be equipped with at least one properly operating wiper to provide clear vision to the driver. If a vehicle is equipped with only one windshield wiper, it is required that the device be so located that when operated it cleans the portion of the windshield directly in front of the driver which is necessary for him to see through in order to properly operate the vehicle.

(b) If a vehicle was originally equipped with two windshield wipers and is less than ten years old, both wipers must operate properly.

(c) The windshield wiper should be capable of operating at a speed necessary to provide the driver a clear view ahead under all conditions of weather.

(d) Windshield wiper blades must not be damaged, hardened, deteriorated, missing or of an improper type (such as a blade designed for a flat windshield installed on a curved windshield) or of improper size.

(e) A windshield wiper blade shall be held against the windshield with adequate pressure to provide the driver a clear view ahead under all conditions of weather.

(f) A windshield wiper shall clean the full area of a windshield for which it was designed.

(g) A windshield wiper control must not be located beyond the reach of the operator and shall be in good working order.

13:20-33.57 Clearance lights; Class III licensees

(a) If the motorcycle is equipped with a side car or any other extension that is attached to the side thereof, there must be clearance light located on the outside limit of the attachment.

(b) Certification shall be refused for any of the following reasons:

1. Clearance light is not of an approved type. Clearance lights must be of a type approved as meeting the Standards of the Society of Automotive Engineers. The letters "SAE" and the letters "P1" or "P2" or "PC" along with the manufacturer's name or trademark are on such lights.
2. Clearance light is insecurely or improperly mounted.
3. Lens is missing, broken or cracked.
4. Clearance light does not display white light to the front.
5. Filament does not light when the headlight switch is turned on to any position.

Note: A three wheel motorcycle should have amber or side clearance lights or parking lights on each side visible from the front of the vehicle.

13:20-33.58 Taillight (red rear light) and reflector and license plate light; Class III licensees

(a) Certification shall be refused for any of the following reasons:

1. Taillight must be of a type approved as meeting the Standards of the Society of Automotive Engineers. The letters "SAE" and the letter "T" along with the manufacturer's name or trademark are often on the lens of such lights.

2. Taillight must be clean and securely mounted. The mounted height of a taillight (measured from center of lens to road surface) shall not be more than 72 inches or less than 20 inches.

3. Lens is missing, broken or of a color other than red. Certification of a motorcycle shall not be refused because taillight lens is cracked, providing no white light shows to the rear; however, the motorcyclist should be advised to have the condition corrected.

4. Filament does not light when headlight switch is turned to any "on" position.

5. Reflector must be of a type approved as meeting the Standards of the Society of Automotive Engineers. The letters "SAE" and the letter "A" (for Class A reflector) or letter "B" (for Class B reflector) along with the manufacturer's name or trademark are often on such reflectors.

6. The reflector shall be clean and properly mounted. Reflector shall be securely mounted not less than 12 inches nor more than 60 inches from the road surface.

Note: There must be a taillight and red reflector on both sides of the rear of three wheel motorcycles.

(b) Certification of a motorcycle shall not be refused if the license plate light is inoperative, but rather the motorcyclist should be advised to have the defect corrected. License plate lights must be of a type approved as meeting the Standards of the Society of Automotive Engineers. The letters "SAE" and the letter "L" along with the manufacturer's name or trademark are often on the lens of such lights.

13:20-33.59 Stoplight; Class III licensees

(a) Certification of a motorcycle shall be refused for any of the following reasons:

1. Stoplight is not red or amber in color.
2. Stoplight is not of an approved type. All stoplights must be of a type approved as meeting the Standards of the Society of Automotive Engineers. The letters "SAE" and the letter "S" along with the manufacturer's name or trademark are often on such lights.
3. Stoplight is not activated by application of the brake.
4. Lens is insecurely or improperly mounted.
5. Lens is missing. Certification of a motorcycle shall not be refused because of a cracked lens providing no white light shows to the rear. However, the motorcyclist shall be advised to have the defect corrected.

6. A three wheel motorcycle should have a red or amber stoplight on each side visible from the rear of the vehicle.

13:20-33.60 Headlights; Class III licensees

(a) Motorcycles shall be inspected and certification refused for any of the following conditions:

1. Motorcycle is not equipped with at least one approved type motorcycle headlight. All headlights must be approved as meeting the Standards of the Society of Automotive Engineers. The letters "SAE" and the letter "M" along with the manufacturer's name or trademark often appear on approved type motorcycle headlights.

2. A motorcycle may have one or two headlights but not more than two. If two are installed both must operate properly and be of an approved type. Motorcycles having motors not over five horsepower may have either multiple beam or single beam headlamps, all other motorcycles must have multiple beam headlights. One seven inches sealed beam passenger car headlamp unit or one 5¾ inches Type 1 and one 5¾ inches Type 2 sealed beam passenger car headlamp unit of approved type may be used if desired.

3. Headlight is not aimed straight ahead with the center of the hot spot of the high beam dropped the following distance in 25 feet: (Aim light with driver in the saddle.)

i. Multiple beam: Four inches drop (plus or minus 2½ inches) in 25 feet.

ii. Single beam: Nine inches drop (plus or minus 2½ inches) in 25 feet.

Note: If seven inches or 5¾ inches sealed beam units are used they shall meet the same aim requirements used for these units on passenger vehicles.

4. Lamp cannot be aimed vertically or is not mounted securely or wiring is not satisfactory or switch does not operate properly.

5. Lens is cracked, missing, broken or improperly installed.

6. There is dirt, moisture, discoloration, contamination or reflector deterioration.

7. High beams are not "on" when the beam indicator lamp is "on".

8. Light intensity is not sufficient (engine speed may be increased in an attempt to obtain sufficient light).

Note: Certification of a motorcycle shall not be refused because the headlight rim is missing but rather the motorcyclist advised to have the condition corrected. Certification of a motorcycle shall not be refused because the headlight switch is eliminated and the headlight is illuminated when the ignition switch is turned on.

13:20-33.61 Exhaust system; Class III licensees

(a) Certification of a motorcycle shall be refused for any of the following reasons:

1. Motorcycle does not have a muffler in good working order.

2. Muffler does not prevent excessive or unusual noise.

3. Muffler is not equivalent in quality and performance to original equipment type designed for highway use.

4. There is a muffler cutout, muffler by-pass or any similar device or any change or modification to the exhaust system, which causes excessive or unusual noise.

5. There are loose or leaking joints, holes, leaking seams, loose components or patches anywhere in the exhaust system. (Small holes obviously made by the manufacturer for drainage purposes are acceptable.) Welding which has been properly done and is in good condition is acceptable but other types of patching cannot be approved.

6. There are excessive fumes or annoying smoke. (There should be no more fumes or smoke than that produced by a properly maintained and functioning motorcycle.)

7. Exhaust system or any of its components are damaged or not fastened securely or properly.

8. There is excessive vibration of the exhaust system.

13:20-33.62 Rear view mirrors; Class III licensees

(a) Certification of a motorcycle shall be refused for any of the following reasons:

1. Motorcycle is not equipped with a mirror.

2. Mirror is discolored, cracked or broken.

3. Mirror is not capable of adjustment to a reasonable fixed position.

4. Mirror is not mounted securely or properly.

5. Mirror does not give driver adequate rear view vision.

13:20-33.63 Miscellaneous lights; Class III licensees

(a) The following lights are not required by New Jersey law but will be permitted providing that they comply with the following regulations:

1. Fog lights and supplemental driving lights:

i. Any motorcycle may be equipped with not more than two auxiliary lights, such as two fog lights, or two supplemental driving or passing lights. These lights

shall be mounted on the front of the vehicle at a height of not less than 12 inches nor more than 42 inches above the road surface.

ii. Shall be approved type. All lights used on motorcycles must be of a type approved as meeting the Standards of the Society of Automotive Engineers. The letters "SAE" along with the manufacturer's name or trademark are often on the lens of such lights. In addition, the letter "F" appears on fog lights and the letter "Y" or "Z" often appears on supplemental driving or passing lights.

iii. Shall be aimed as provided under headlights.

iv. Shall be securely mounted.

2. Turn signal lights (required on three wheel motorcycles);

i. Two lights visible from the front and two lights visible from the rear.

ii. Entire turn signal system must be of an approved type. All turn signal lights, flashers and operating units must be of a type approved as meeting the Standards of the Society of Automotive Engineers. The letters "SAE" along with the manufacturer's name or trademark are often on such devices. In the case of front and rear turn signal lights, the letter "I" or the letter "D" is often on the lens.

iii. Lights showing to the front must be amber or white in color.

iv. Lights showing to the rear must be amber or red in color.

v. Lights should be in proper operating condition. Certification of a motorcycle shall not be refused because a turn signal light has a cracked lens but rather the motorcyclist advised to have the defect corrected.

3. Spot lights: A spot light is a light which can be aimed at will. Any motor vehicle may be equipped with not more than one spot light but the use of any such spot light for driving purposes is prohibited. The letters "SAE" and the letter "O" along with the manufacturer's name or trademark are often on the lens of approval type spot lights. Spot lights shall be of a type approved by the Director. Approved spot lights shall meet the requirements of SAE J-591b.

4. Flashing emergency lights are prohibited on motor vehicles except as a means for indicating a right or left turn or for hazard warning signals or for authorized emergency vehicles (vehicles of a fire department, police vehicles and other vehicles having special permits for flashing emergency warning lights).

5. Special lights:

i. A vehicle owned by an active member in good standing of a recognized volunteer fire company may be equipped with one flashing (or non-flashing) special blue light not more than 7½ inches in diameter or more than 21 candlepower. The special light shall be installed on the front of the vehicle so that the top of the special light is no higher than the top of the vehicle headlights and shall be controlled by a switch installed inside the vehicle.

ii. A vehicle owned by an active member in good standing of a first aid squad affiliated with the New Jersey First Aid Council may have a special non-flashing white light not exceeding 21 candlepower with a lens not more than four inches in diameter and having an illuminated gold cross on a white background. The light must be mounted on the exterior of the vehicle so that it will not be at a greater height from the ground than the headlights.

iii. Two or more lighting devices and reflectors may be combined optically, but the following combinations are prohibited:

(1) A turn signal with a headlight;

(2) A clearance light with a taillight or identification light.

iv. There are other motor vehicle lights which are not covered in detail in this manual. The manufacturer's name or trademark and the letters "SAE" often appear on the lens of such lights along with the identification letters shown below:

(1) E: Side turn signal lamps (mounted on vehicle sides);

(2) K: Cornering lamps;

(3) M: Motorcycle and motor driven cycle headlamps—motorcycle type;

(4) N: Motorcycle and motor driven cycle headlamps—motor driven cycle type;

(5) R: Back-up lamps;

(6) U: Supplemented high-mounted stop and turn signal lamps;

(7) V: Liquid burning emergency flares;

(8) W4: Emergency reflex reflectors;

(9) X: Electric emergency lanterns.

As amended, R.1979 d.193, eff. May 14, 1979.
See: 11 N.J.R. 199(a), 11 N.J.R. 298(c).

**13:20-33.64 Wiring, switching and electrical equipment;
Class III licensees**

(a) Certification of a motorcycle shall be refused for any of the following reasons:

1. Switches and wiring are not in satisfactory condition.
2. Switches do not function properly.
3. Wiring improperly installed or located so as to cause damage.
4. Power for lights is not provided by a generator, alternator or magneto (dry cell batteries are not acceptable as a source of electrical energy except for parking lights).

NOTE: Certification of a motorcycle shall not be refused because the headlight switch is eliminated and the headlight is illuminated when the ignition switch is turned on.

13:20-33.65 Beam indicator lights*; Class III licensees

(a) Certification of a motorcycle shall be refused if the headlight beam indicator light is not visible to operator.

(b) Certification of a motorcycle shall not be refused because the beam indicator light is inoperative but rather the motorcyclist advised to have the defect corrected.

* Note: Headlight beam indicator light is not required on vehicles equipped with single beam headlights.

13:20-33.66 Miscellaneous items; Class III licensees

(a) Certification of a motorcycle shall be refused for the following reasons:

1. Fuel leakage at any point in the fuel system.
2. Fuel tank cap and piping are not in proper condition.
3. Chainguard does not provide sufficient protection.

Note: The rear fenders of three wheel motorcycles must extend downward to the rear at least three quarters of the distance from the top of the tire to the horizontal centerline of the tire. Flaps may be attached to the rear fenders to provide the required length.

13:20-33.67 Tires; Class III licensees

(a) Certification of a motorcycle shall be refused for the following reasons:

1. Tire tread design is worn to the point where the tread depth is less than $\frac{2}{32}$ of an inch at three locations spaced approximately equally around the outside of the tire.
2. Any part of the ply or cord is exposed.
3. There are scuffs, cuts or snags deep enough to expose the body cords.
4. The tire structure has a bump, bulge, knot or separation.

5. A tire which has been regrooved below the original tread depth unless such tire was originally manufactured with extra undertread material and is marked "regroovable."

13:20-33.68 Brakes (including pedal reserve, service brake equalization and parking brakes on three wheel motorcycles); Class III licensees

(a) Certification of a motorcycle shall be refused for any of the following reasons:

1. Motorcycle is not equipped with at least one brake adequate to control the movement of and stop the motorcycle within a safe distance. (1974 and later models should have front and rear brakes as required by Federal standards.)

2. Levers (foot and hand) do not have at least one-third of their travel as reserve after brakes are fully applied.

3. Any leaks in a hydraulic brake system.

4. Any defects in mechanical components.

Note: There must be a parking brake in good operating condition on a three wheel motorcycle.

(b) The parking brake shall be able to hold the vehicle stationary on any up or downgrade upon which it can be operated whether the vehicle is empty or loaded.

(c) The parking brake must be equipped with an automatic locking device which will hold the brake in the applied position.

(d) When the parking brake is applied there must be a minimum of one-third of the total average travel (vehicle manufacturer's specifications) remaining.

(e) The service brakes on a three wheel motorcycle shall be properly equalized.

13:20-33.69 Helmets; Class III licensees

(a) Certification of a motorcycle shall be refused for any of the following reasons:

1. There is not an approved type safety helmet available for the motorcycle operator. An approved type helmet is marked to meet Standard Z90.1 of the American National Standards Institute or Federal Standard 218 along with the manufacturer's or distributor's trademark.

2. The safety helmet is not equipped with either a neck or chin strap.

3. The protective helmet is not reflectorized over an area of at least four square inches on each side of the helmet. Red, white or amber reflectorized safety tape shall be used and securely affixed in a permanent water-

proof manner. Helmets having built-in reflectorization must also have the reflectorized tape.

13:20-33.70 Goggles or face shields; Class III licensees

(a) A motorcycle operator is not required to have goggles or a face shield if the motorcycle is equipped with an approved type windscreen. (Refer to section 54 of this subchapter.) If the motorcycle is not equipped with approved type windscreen it should not be certified unless the operator has either approved type goggles or an approved typeface shield.

(b) Approved type goggles and approved type face shields are marked to meet Standard Z2.1 or Standard Z87.1 or Regulation V-8. The letters and numbers Z2.1 or Z87.1 or V-8 appear on such goggles and face shields along with the trademark of the manufacturer or distributor.

13:20-33.71 Seats; Class III licensees

(a) Motorcycles designed for occupancy by two people may have either one permanent seat designed for two persons or a separate passenger seat located to the rear or side of the seat for the operator.

(b) Certification of a motorcycle shall be refused for any of the following reasons:

1. Seats are not equivalent in quality and safety to original equipment type.
2. Each seat is not securely mounted.
3. Seats are not of sufficient strength or are mounted in such a manner that operator and passenger cannot ride without crowding or interfering with operation of the vehicle.

13:20-33.72 (Reserved)

As amended, R.1981 d.17, eff. January 16, 1981.
See: 12 N.J.R. 607(a), 13 N.J.R. 150(a).
Section was "Handholds; Class III Licensees".

13:20-33.73 Foot rests; Class III licensees

(a) Motorcycles designed to carry more than one person shall be equipped with adequate foot rests for each passenger.

(b) Certification of a motorcycle shall be refused for any of the following reasons:

1. Foot rests are not equivalent in quality and performance to original equipment type.
2. Foot rests are not securely mounted.
3. Foot rests are not capable of supporting the full weight of the user.
4. Foot rests for passengers are mounted in such a manner as to interfere with the operation of a motorcycle.

**TABLE 3
AVERAGE LENGTH OF TIME REQUIRED
TO REINSPECT A SPECIFIC ITEM ON
A MOTORCYCLE**

Rejection Item Number as Shown on Inspection Card	Item Reinspected	Time Required
3, 14	Steering, Handlebars and Suspension	.2 Hour
5	Parking Lights	.1 Hour*
6	Glazing	.2 Hour
7	Obstruction to Driver's View	.1 Hour*
8	Horn	.1 Hour*
9	Windshield Wipers	.2 Hour
10	Direction (Turn) Signals, Hazard Warning Lights	.2 Hour
11	Side-Marker, Clearance, Identification Lights, Reflectors	.2 Hour
12	Red Rear Light, Plate Light	.2 Hour
13	Stop Lights	.1 Hour*
15	Exhaust System (Inc. Smoke)	.2 Hour
16	Head Lights	.2 Hour
17	Mirrors	.1 Hour*
18	Other Lights	.2 Hour
19,21	Wiring, Switching, Electrical	.2 Hour
21	Wheels, Tires, Miscellaneous	.2 Hour
22	Service Brake	.2 Hour (For either 22 or 24 on Inspection Card or both)
23	Parking Brake and Reserve	.2 Hour
24	Brake Equalization	.2 Hour (For either 22 or 24 on Inspection Card or both)
25	Service Brake Pedal Reserve	.2 Hour
26	Helmet	.1 Hour*
27	Goggles, Face Shield	.1 Hour*
28	Seat, Hand Holds, Foot Rest	.1 Hour*

* Note: If this is the only item to be reinspected on a motorcycle the reinspection time shall be considered to be .2 hour.

Editor's Note: In addition to the above text, an example of the Inspection Card for Motorcycles was filed and adopted as part of these rules, but is not reproduced herein. Further information regarding the form may be obtained from the Division of Motor Vehicles, 25 South Montgomery Street, Trenton, New Jersey 08625.

SUBCHAPTER 34. IDENTIFYING MARKS

Subchapter Historical Note

Unless otherwise expressly noted, all provisions of this Subchapter were adopted pursuant to authority of N.J.S.A. 39:3-33.3 and were filed and became effective on September 24, 1976, as R.1976 d.302, See: 8 N.J.R. 400(b), 8 N.J.R. 532(a).

13:20-34.1 Definitions

The following words and terms, when used in this Subchapter shall have the following meanings unless the context clearly indicates otherwise.

"Courtesy marks" means particular identifying marks having inscribed thereon motor vehicle registration numbers comprised of three alphabetic characters and any number from 1 through 20, except those combinations hereinafter reserved.

“Legislature courtesy marks” mean courtesy marks hereinafter reserved for members of the Senate and General Assembly of the State of New Jersey.

“Particular identifying mark or marks” mean motor vehicle license plates having inscribed thereon motor vehicle registration numbers comprised of combinations of letters or numbers, or both, requested by the registrants.

“Personalized marks” mean particular identifying marks having inscribed thereon motor vehicle registration numbers comprised of any combination of alphabetic characters or numbers, or both, except combinations defined as courtesy marks.

13:20-34.2 Registration numbers reserved

(a) The following registration numbers are reserved as specified:

1. Registration numbers comprised of two alphabetic characters only and registration numbers comprised of one alphabetic character and a single digit for vehicles owned or leased by members of the Senate of the State of New Jersey; SP for a vehicle owned by, or leased by or for, the President of the Senate of the State of New Jersey;
2. Registration numbers comprised of two alphabetic characters and one digit for vehicles owned or leased by members of the General Assembly of the State of New Jersey; SPKR for a vehicle owned by, or leased by or for, the Speaker of the General Assembly of the State of New Jersey;
3. U.S.S. 1 and U.S.S. 2 for vehicles owned or leased by United States Senators representing the State of New Jersey;
4. U.S. 1 through U.S. 20 for vehicles owned or leased by members of Congress representing districts in the State of New Jersey;
5. MD A 1 through MD Z 999, 1 MD A through 99 MD Z, MD 1000 through MD 9999, 1000 MD through 9999 MD, and MD 1 A through MD 99 Z for vehicles owned or leased by persons licensed to practice medicine and surgery in New Jersey or neighboring states;
6. NJP 1 through NJP 999 and 1 NJP through 999 NJP for vehicles owned or leased by persons accredited as members of the “Press” in New Jersey.
7. NYP 1 through NYP 999 and 1 NYP through 9999 NYP for vehicles owned or leased by persons accredited as members of the “Press” in the City of New York, New York;
8. PBA, PBA 1 through PBA 999 and 1 PBA through 999 PBA for incumbent officers of the State Patrolmen’s Benevolent Association, Inc.;
9. QQA 1 through QQZ 999, 1 QQA through 999 QQZ, QQ1 A through QQ999 Z, 100 AQQ through 999 ZQQ, and QQ 1000 through QQ 99999 for “historic” vehicles registered pursuant to N.J.S.A. 39:3-27.3 et seq.; Q1 through Q9999 for “historic” motorcycles;
10. DAV 1 through DAV 999, 1 DAV through 999 DAV, DV 1 through DV 9999 and 1 DV through 9999 DV for vehicles owned by members of “Disabled American Veterans” of New Jersey;
11. VFW 1 through VFW 999 and 1 VFW through 999 VFW for vehicles owned or leased by members of “Veterans of Foreign Wars of the United States, State of New Jersey”;
12. DAA 1 through DZZ 99 and 1 DAA through 99 DZZ for issuance to licensed motor vehicle dealers pursuant to N.J.S.A. 39:3-18;
13. A11A through Z99Z and 1AA1 through 9ZZ9 for vehicles owned by any bona fide firefighter (paid, partially paid, or volunteer);
14. F 1000 through F 999 and 1000 F through 9999 F for vehicles owned by any bona fide members of first aid or rescue squads;
15. P 1000 through P 9999 and 1000 P through 9999 P for vehicles owned by any person who served in the armed forces of the United States and who was held as a prisoner of war by an enemy of the United States during any armed conflict;
16. R 1000 through R 9999 and 1000 R through 9999 R for vehicles manufactured before 1949 and registered with a New Jersey street rod club affiliated with the National Street Rod Association, Inc.;
17. H 1000 through H 9999, 10000 H through 9999 H, HA 1000 through HZ 9999 and 1000 HA through 999 HZ for vehicles that qualify under New Jersey Motor Vehicle Law 39:4-204 through 207;
18. NGA 1 through NGZ 999 and 1 NGA through 999 NGZ and any combination beginning with NG for vehicles owned by active members of or former active members who have been honorably separated from members of the New Jersey Air National Guard or Army National Guard;
19. A 1 AA through Z 9 ZZ, except for those combinations beginning with the letters A, K, N or W which are reserved for amateur radio call letter registrations, for vehicles owned or leased by a County Office of New Jersey. The first letter will designate the county code. Freeholder, Surrogate, County Clerk, and Sheriff will be assigned numbers one through three. All other plates will bear the title County Officer with assigned numbers four through nine;
20. DDS 001 through DDS 999 and 001 DDS through 999 DDS and DMD 001 through DMD 999 and 001

DMD through 999 DMD and any combination of one to three letters with DDS or DMD owned by New Jersey residents licensed to practice dentistry in New Jersey or neighboring states;

21. DPM 100 through DPM 999 and 100 DPM through 999 DPM and any combination of one to three letters with DPM owned by New Jersey residents licensed to practice podiatry in New Jersey or neighboring states;

22. 1 DC 1 through 1 DC 999 owned by New Jersey residents licensed to practice chiropractic medicine in New Jersey or neighboring states;

23. DO 1000 through DO 9999 and 1000 DO through 9999 DO for vehicles owned or leased by osteopathic physicians licensed to practice medicine and surgery in New Jersey or neighboring states;

24. AA1AA through ZZ9ZZ for vehicles owned or leased by the mayor or chief executive of a municipality in this State;

25. USS NJ, USS NJ 1 through 9 to be set aside for the members of the USS New Jersey Battleship Commission;

26. SA 1000 through SA 9999 and SA 100A through SZ 999Z, except that the letters I, O and Q shall not be utilized in such non-personalized plate combinations. Designated for use on Coastal Protection license plates issued by the Division pursuant to N.J.S.A. 39:3-27.48;

27. IM 1000 through IM 9999 and IM 100A through IM 999Z, except that the letters O and Q shall not be utilized in such non-personalized plate combinations. Designated for use on Animal Welfare license plates issued by the Division pursuant to N.J.S.A. 39:3-27.55;

28. CW 1000 through CW 9999, 1000 CW through 9999 CW, and CW 100A through CW 999Z, except that the letters I, O and Q shall not be utilized in such non-personalized plate combinations. Designated for use on Wildlife Conservation license plates issued by the Division pursuant to N.J.S.A. 39:3-33.10;

29. AA 100A through AZ 999Z are reserved for future use;

30. Three alphabetic characters plus 1 through 20 and 1 through 20 plus three alphabetic characters designated as "courtesy plates" approved by county senators.

(b) Notwithstanding the above reservations, the Director in his discretion may issue marks reserved for members of the United States Senate and House of Representatives, and the Senate and General Assembly of New Jersey to vehicles owned by spouses of said members or to vehicles owned by firms or corporations of which said members are owners, partners or employees.

Amended by R.1985 d.101, effective March 4, 1985.
See: 16 N.J.R. 2743(a), 17 N.J.R. 601(a).
Substantially amended.

Amended by R.1992 d.264, effective June 15, 1992.
See: 24 N.J.R. 1467(b), 24 N.J.R. 2283(b).

Revised text.

Amended by R.1994 d.314, effective June 20, 1994.
See: 26 N.J.R. 1487(a), 26 N.J.R. 2587(b).

13:20-34.3 Registration numbers excluded

(a) The following registration numbers shall be excluded from issuance as "particular identifying marks" and, where so indicated, shall be used for the purpose specified:

1. Any combination except those hereinbefore reserved having the following arrangements: three alphabetic followed by three numeric characters (for example ABC 123); three numeric followed by three alphabetic characters (for example 123 ABC); three alphabetic followed by two numeric and one alphabetic character (for example, ABC 12D); two alphabetic followed by three numeric and one alphabetic character (for example, BA 123C), except that the letters I, O and Q shall not be utilized in this type of six character non-personalized plate combination; three alphabetic followed by four numeric characters (for example, ABC 1234), except that the letters I, O and Q shall not be utilized in such seven character non-personalized plate combinations. Any combination herein excluded and not in a series designated for special classes of vehicles may be reissued as "personalized marks" if the registrant to whom the marks were previously issued has surrendered said marks and corresponding registration certificate. Designated for general issue;

2. "1" through "30" except "22 and 25". Designated for State vehicles assigned to cabinet officers;

3. "100 through 19000". Designated for "constructor" registrations;

4. Except as otherwise provided by N.J.A.C. 13:20-34.2(a)1 and 13:20-34.2(a)9, any combination consisting of less than three characters or more than seven characters;

5. Any combination consisting of one alphabetic followed by two numeric characters (for example, A 12). Designated for "contractor equipment in transit registration";

6. "AA 10" through "YZ 99", except for QQ 1 to QQ 99. Designated for "contractor equipment in transit registration". "ZA 10" through "ZZ 99". Designated for "empty contractor equipment in transit registration";

7. Any combination having two alphabetic followed by three numeric characters (for example, AB 123) or three numeric followed by two alphabetic characters (for example, 123 AB). Designated for general motorcycle registrations (A100A through Z999Z new series);

8. F 10000 through F 99999, FA 10000 through FA 99999, and FA 10A through FZ 99Z. Designated for "farm use registrations" issued pursuant to N.J.S.A. 39:3-24(b);

9. "G" followed by three numeric characters (for example G 123) and three numerics followed by "G" (for example, 123 G). Designated for motorcycles owned by governmental agencies;

10. "H" followed by three numeric characters (for example, H 123) and three numerics followed by "H" (for example, 123 H). Designated for motorcycles owned by governmental agencies;

11. "J" followed by three numeric characters (for example J 123) and three numerics followed by "J" (for example, 123 J). Designated for motorcycles owned by governmental agencies;

12. "MV 1" through "MV 10" and "1 MV" through "10 MV". Designated for State vehicles assigned to Division of Motor Vehicles personnel;

13. S1 100A through S1 999Z and 100A S1 through 9999Z S1 for School Vehicle Type I; S2 100A through S2 999Z and 100A S2 through 9999Z S2 for School Vehicle Type II;

14. TA 100 through TZ 9999, TAA 100 through TZZ 9999, TA100A through TZ999Z, 100 TAA through 999 TZZ, and T100AA through T999ZZ for commercial trailers and semitrailers; provided, however, that the letters I, O and Q shall not be utilized in seven character combinations issued for commercial trailers and semitrailers;

15. XA 100 through XZ 9999, XAA 100 through XZZ 9999, XA1000 through XZ9999, X10000 through X99999, X1A100 through X9Z999, XAA10A through XXZ99Z, XX10AA through XX99ZZ, and X100AA through X999ZZ for commercial motor vehicles; provided, however, that the letters I, O and Q shall not be utilized in seven character combinations issued for commercial motor vehicles;

16. SGA 1 through SGZ999, 1 SGA through 999 SGZ, SG 1000 through SG 99999, and 1000 SG through 9999 SG for State-owned vehicles; CGA 1 through CGZ 999, 1 CGA through 999 CGZ, CG 100A through CG 999Z, CG 1000 through CG 99999, and 1000 CG through 9999 CG for county-owned vehicles; MGA 1 through MGZ 999, 1 MGA through 999 MGZ, MG 10AA through MG 99ZZ, MG 1000 through MG 99999, and 1000 MG through 9999 MG for municipal-owned vehicles; TD 1000 through TD 9999 and 100 TD through 9999 TD for State-owned vehicles assigned to the Department of Transportation;

17. ACE 21 through ACE 99 and 21 ACE through 99 ACE for vehicles owned by the New Jersey Expressway Authority; HAA 1 through HAZ 999 and 1 HAA through 999 HAZ for vehicles owned by the New Jersey Highway Authority; TPA 1 through TPA 999, 1 TPA

through 999 TPA, and TPA 10A through TPA 99Z for vehicles owned by the New Jersey Turnpike Authority.

18. OXV 100 through OZZ 9999 for vehicles utilized as buses for hire;

19. XYA 10A through XZD 99Z and XY 10AA through XZ99ZZ for vehicles utilized as farmer trucks;

20. CV 1000 through CV 9999 and 1000 CV through 9999 CV for vehicles utilized as commuter vans for hire;

21. TR 1000 through TR 9999, TRA 100 through TRM 999, TSA 100 through TSF 999 and 1000 TA through 9999 TZ for tractors utilized on farms;

22. OL 4000 through OL 9999 and 4000 OL through 9999 OL for vehicles utilized as taxis for hire;

23. SPA 100 through SPA 999, 100 SPA through 999 SPA, SPB 100 through SPB 999, 100 SPB through 999 SPB, SP 1000 through SP 9999, and 1000 SP through 9999 SP, used for State Police designated vehicles;

24. OL 1000 through OL 3999 and 1000 OL through 3999 OL for vehicles utilized as limousines or taxis for hire with PUC approval;

25. Any combination except those hereinbefore reserved having the following arrangements: AAA 100 through ZZZ 9999, 100 AAA through 999 ZZZ and AAA 10A through ZZZ 99Z for vehicles utilized as pleasure vehicles; provided, however, that the letters I, O and Q shall not be utilized in seven character non-personalized plate combinations issued for vehicles utilized as pleasure vehicles; BA 100A through ZZ 999Z for vehicles utilized as pleasure vehicles, except that the letters I, O and Q shall not be utilized in this type of six character non-personalized plate combination issued for vehicles utilized as pleasure vehicles;

26. 1A1A1 through 9Y9Y9 for motorized bicycles;

27. Any combination of alphabetic and numeric characters that constitutes amateur radio call letters as issued by the Federal Communications Commission;

28. Three letters followed by CMH. Designated for vehicles owned or leased by New Jersey residents who have been awarded the Congressional Medal of Honor;

29. 1000 SS through 9999 SS for vehicles owned or leased by persons who have been awarded the Silver Star medal;

30. CI 1000 through CI 9999 and 1000 CI through 9999 CI for vehicles owned or leased by persons who are holders of the Combat Infantryman Badge;

31. AR 1000 through AR 9999, NR 1000 through NR 9999, CR 1000 through CR 9999, AF 1000 through AF 9999 and MR 1000 through MR 9999 for vehicles owned by persons serving in military reserve units;

32. NFA 100 through NFZ 999 and NF 10000 through NF 99999 for vehicles that qualify for registration at no fee pursuant to N.J.S.A. 39:3-27 and which are not assigned specific combinations by any other provision of this subchapter;

33. Except as otherwise provided by this subchapter, any combination consisting of two alphabetic followed by four numeric characters (for example, AB 1234) or four numeric followed by two alphabetic characters (for example, 1234 AB). Designated for use on special organization vehicle registration plates issued by the Division pursuant to N.J.S.A. 39:3-27.35 et seq. and N.J.A.C. 13:20-39;

34. Any combination of alphabetic characters or numbers, or both, that may carry connotations offensive to good taste and decency.

Amended by R.1985 d.101, effective March 4, 1985.
See: 16 N.J.R. 2743(a), 17 N.J.R. 601(a).

Substantially amended.

Amended by R.1992 d.264, effective June 15, 1992.
See: 24 N.J.R. 1467(b), 24 N.J.R. 2283(b).

Revised text.

Amended by R.1994 d.314, effective June 20, 1994.
See: 26 N.J.R. 1487(a), 26 N.J.R. 2587(b).

13:20-34.4 Denials, suspension or revocation

(a) "Particular identifying marks" shall not be issued to any person who:

1. Has been convicted of a violation of N.J.S.A. 2C:11-5;
2. Has been convicted of a violation of either N.J.S.A. 39:4-50, or N.J.S.A. 39:4-96;
3. Has had a suspension or revocation of driving privileges in effect at any time within the two-year period next preceding the date of application for such marks.

(b) Any cause for which issuance of particular identifying marks may be denied which arises subsequent to the issuance of such plates shall also be cause for the suspension or revocation of particular identifying marks;

(c) A material misstatement of fact on an application therefor shall be cause for suspension or revocation of particular identifying marks.

(d) Any person to whom particular identifying marks have been issued which identify that person as a United States Senator or Congressman, State Senator or Assemblyman, member of the "Press" accredited in New Jersey or New York City, Officer of the New Jersey State Patrolmen's Benevolent Association, Inc., first aid or squad member, firefighter member, or county officer shall surrender said plates to the Division together with the corresponding motor vehicle registration certificate immediately upon the termination of said office or accreditation unless otherwise provided by law. The failure to so surrender said plates shall be cause for the revocation of the particular identifying marks.

Amended by R.1985 d.101, effective March 4, 1985.

See: 16 N.J.R. 2743(a), 17 N.J.R. 601(a).

(a) added: "2C:11-5" and deleted "misdemeanor in"; (d) added: "first aid or squad member, fire-fighter member, or county officer".

13:20-34.5 Fees

(a) Fees for particular identifying marks, which shall be paid with the application therefor, shall be as follows unless otherwise provided by law:

1. "Courtesy marks": \$30.00;
2. "Personalized marks": \$100.00;
3. Replacement of lost, stolen or obliterated "particular identifying marks": \$11.00.

(b) Except as otherwise provided by (a)3 above, a fee of \$6.00 shall be paid for replacement of lost, stolen or obliterated license plates.

Amended by R.1985 d.101, effective March 4, 1985.

See: 16 N.J.R. 2743(a), fees changed from \$5.00 to \$10.00.

Amended by R.1992 d.264, effective June 15, 1992.

See: 24 N.J.R. 1467(b), 24 N.J.R. 2283(b).

Added (b).

Amended by R.1995 d.365, effective July 3, 1995.

See: 27 N.J.R. 1521(b), 27 N.J.R. 2592(b).

Increased the fees.

13:20-34.6 Transfers to survivor

(a) The surviving spouse, child or children of a deceased registered owner of any motor vehicle in whom title thereto shall vest by virtue of the terms of the will of such deceased owner, or otherwise, shall upon application to the director and upon payment of the transfer fee of \$4.50 specified in N.J.S.A. 39:3-30 be entitled to have the particular identifying mark issued for said vehicle transferred to his or her name provided that said survivor meets the qualifications therefor specified by law and these rules.

Amended by R.1985 d.101, effective March 4, 1985.

See: 16 N.J.R. 2743(a), 17 N.J.R. 601(a).

Transfer fee changed from "\$3.00" to "\$4.50".

13:20-34.7 Reissue

In the event a registrant fails to renew the registration for a particular identifying mark for two years from the date of expiration or surrenders said mark and corresponding registration certificate to the Division, said marks shall be available for reissuance to any applicant therefor upon payment to the Division of the applicable fee specified in N.J.A.C. 13:20-34.5(a) for said marks.

Amended by R.1984 d.157, effective May 7, 1984.

See: 16 N.J.R. 347(b), 16 N.J.R. 1095(c).

"Two consecutive registration years" deleted; "60 days from date of expiration" substituted.

Amended by R.1992 d.264, effective June 15, 1992.

See: 24 N.J.R. 1467(b), 24 N.J.R. 2283(b).

SUBCHAPTER 35. INSPECTION OF STATE-OWNED VEHICLES BY THE CENTRAL MOTOR POOL

Authority

Unless otherwise expressly noted, all provisions of this subchapter were adopted pursuant to authority of N.J.S.A. 39:8-1 et seq. and were filed and became effective on December 21, 1977, as R.177 d.480. See: 9 N.J.R. 486(b), 10 N.J.R. 71(c).

13:20-35.1 Application of subchapter

This subchapter shall apply to motor vehicles owned by the State of New Jersey which are subject to the control of the central motor pool in the Department of the Treasury for service, maintenance and release to government employees for use in the performance of governmental functions.

13:20-35.2 Inspection by the central motor pool

Motor vehicles within the purview of this subchapter shall be examined and inspected in accordance with the provisions of chapter 8 of the motor vehicle laws by the central motor pool in the Department of the Treasury.

13:20-35.3 Inspection standards and frequency

Motor vehicles or motor vehicle equipment inspected in accordance with this subchapter shall comply with any laws and regulations providing vehicle equipment standards and/or specifying frequency of inspections.

13:20-35.4 Inspection decal

Whenever a motor vehicle inspected in accordance with this subchapter is determined to comply satisfactorily with vehicle equipment standards provided by law and regulation, the central motor pool shall affix upon the windshield of such vehicle the decal prescribed by the Director of Motor Vehicles as indicative of compliance with the inspection laws.

13:20-35.5 Facilities

Facilities used by the central motor pool in performing inspections of motor vehicles hereunder shall be equipped with the machinery necessary for inspecting all vehicle equipment standards provided by law and regulation.

13:20-35.6 Instruction of mechanics

The central motor pool shall instruct mechanics who are to perform inspections under this subchapter of vehicle equipment standards provided by law and regulation.

13:20-35.7 Certification

A mechanic performing an inspection under this subchapter shall certify to the director that he has inspected the

motor vehicle in accordance with the vehicle equipment standards established by law and regulation.

SUBCHAPTER 36. SPECIAL NATIONAL GUARD PLATES

Authority

N.J.S.A. 39:3-27.14.

Source and Effective Date

R.1985 d.678, effective December 18, 1985.
See: 17 N.J.R. 2602(a), 18 N.J.R. 203(a).

Subchapter Historical Note

All provisions of this subchapter became effective January 28, 1981 as R.1981 d.31. See: 12 N.J.R. 427(a), 13 N.J.R. 150(e). Amendments became effective August 6, 1984 as R.1984 d.319. See: 16 N.J.R. 1188(a), 16 N.J.R. 2142(a). This subchapter was readopted pursuant to Executive Order 66(1978) effective December 18, 1985 as R.1985 d.678. See: 17 N.J.R. 2602(a), 18 N.J.R. 203(a). See chapter and section levels for further amendments.

13:20-36.1 Application; certification; fees

(a) Application for special National Guard plates may be made by any person who is an active member of the New Jersey National Guard or former active member who has been honorably separated under normal conditions from the New Jersey National Guard. An active or separated member of the New Jersey National Guard may make application for no more than two motor vehicles owned by him. The Division of Motor Vehicles will issue no more than two sets of special National Guard plates to each active or separated member of the New Jersey National Guard.

(b) An application for special National Guard plates must be obtained from the Commander of the National Guard Unit of which the applicant is an active member, or retired members may obtain an application from the New Jersey Department of Defense.

1. The Commander shall certify that the applicant is an active or separated member of the New Jersey National Guard.

2. The Commander shall forward the completed application together with the fee established in this section to the Division's Special Plate Unit.

3. The Special Plate Unit shall notify the Department of Defense when the special National Guard plates are issued to an applicant.

(c) A fee of \$15.00 for each set of plates shall be paid at the time of application for special National Guard plates. A fee of \$5.00 shall be paid for replacement of lost, stolen or obliterated special National Guard plates.

As amended, R.1984 d.319, eff. August 6, 1984.

See: 16 N.J.R. 1188(a), 16 N.J.R. 2142(a).
Section substantially amended.

13:20-36.2 Surrender of special plates

(a) Whenever the holder of special National Guard plates ceases to be an active member of the New Jersey National Guard for reasons other than honorable separation or for honorable separation under abnormal conditions, he shall obtain replacement plates from the Division of Motor Vehicles, within five days of his separation from the New Jersey National Guard and he shall then surrender the National Guard plates to the Department of Defense.

1. The Department of Defense shall forward the surrendered plates to the Division of Motor Vehicles.

2. If the special National Guard plates are not surrendered to the Department of Defense within five days from the date the holder of special plates ceases to be an active member of the New Jersey National Guard, the Department of Defense shall notify the Division of Motor Vehicles of the holder's failure to surrender the special plates.

As amended, R.1984 d.319, eff. August 6, 1984.

See: 16 N.J.R. 1188(a), 16 N.J.R. 2142(a).

(a) added: "for reasons other . . . abnormal conditions".

SUBCHAPTER 37. STANDARDS FOR MOTOR VEHICLES WITH MODIFIED CHASSIS HEIGHT

Authority

N.J.S.A. 39:3-43, 39:8-2 and 39:10-4.

Source and Effective Date

R.1985 d.100, effective March 4, 1985.
See: 16 N.J.R. 2501(a), 17 N.J.R. 603(a).

13:20-37.1 Modification of height of motor vehicle restricted; approval of the director

(a) No person shall operate on any highway of this State any motor vehicle whose height has been altered, modified or changed by elevating or lowering the chassis or body from the manufacturer's specifications by use of "shackle lift kits" for leaf springs or by use of lift kits for coil springs or blocks or any other device without the prior written approval of the director.

13:20-37.2 Requirements for motor vehicle approval

(a) To be approved, a vehicle shall meet the following standards:

1. The suspension system shall consist of the basic elements originally provided by the manufacturer and be geometrically arranged in accordance with the manufacturer's specifications. No suspension system component shall be replaced unless the replacement component meets or exceeds the quality and performance standards established by the vehicle manufacturer. The vehicle shall have a suspension system that allows movement between the unsprung axles and wheels and the chassis body and shall be equipped with a shock-absorbing device at each wheel location. The suspension system shall be capable of providing a minimum relative motion of plus and minus two inches. When any corner of the vehicle is depressed and released, the damping device shall stop vertical body motion within two cycles. The use of spacer blocks between the front axle and leaf springs is prohibited.

2. The steering wheel shall move not less than two turns nor more than six turns, and shall remain unobstructed when turning from stop to stop. The number of turns to right stop shall be equal to the number of turns to left stop. A tolerance of one-quarter turn is permitted.

3. Headlights shall be no lower than 24 inches nor higher than 54 inches from the ground to the center of the lamp. Taillights shall be no lower than 15 inches nor more than 72 inches from the ground to the center line of the lamp. All lighting equipment must meet the standards of the Society of Automotive Engineers.

4. License plates shall be no lower than 12 inches nor higher than 48 inches from the ground. N.J.S.A. 39:3-33.

5. Brake lines and hoses shall conform to 49 C.F.R. 571.106 and shall be protected from excessive heat and vibration and be installed so as to prevent chafing.

6. Where the vehicle was originally equipped by the manufacturer with bumpers, all bumpers must be securely mounted, extend across the full width of the vehicle and be horizontal load bearing bumpers attached to the vehicle frame to effectively transfer impact when engaged. Bumpers shall not have sharp edges or dangerous configurations. Bumpers shall be mounted to be no lower than 16 inches from the ground to the bottom of the bumper.

7. All tires on the same axle or on axles less than six feet apart shall be of the same tire size with respect to diameter and width. Each tire shall have a load carrying capacity specified by the tire manufacturer in excess of the intended maximum axle load divided by the number of tires on the axle. Each front tire shall measure a minimum of 60 percent of the tread width of the rear tires. Tires shall have a minimum four inch vertical clearance and two inch horizontal clearance so as not to rub on the chassis, body, suspension or other part of the vehicle while being operated.

8. Fenders shall extend the full width of the tires or the vehicle must be equipped with suitable metal protectors or substantial flexible flaps so as to prevent the throwing of dirt, water or other debris on following vehicles. The metal protectors or flexible flaps shall be of such standard type or design and installed in such manner as shall be approved by the director and shall conform substantially to any requirement of the Interstate Commerce Commission governing similar subject matter.

9. Fuel tanks which have become exposed as a result of raising the vehicle shall be protected against damage from collision by some means of encasement.

10. All moving parts or exhaust system components which have become exposed as a result of raising the vehicle shall be shielded to prevent injury to persons making contact with these parts.

11. Any ballast material used for the purpose of adding weight to the vehicle must be permanently attached to the vehicle structure. No liquid or loose ballast is permitted.

12. Release of the steering wheel while the vehicle is in a sharp turn at a speed of between five to ten miles per hour will result in a distinct tendency for the vehicle to increase its turning radius.

13. The weight distribution between the two sides of an empty vehicle on level ground shall not exceed 45 percent/55 percent.

13:20-37.3 Standards for vehicles with modified height

(a) If a motor vehicle has been raised more than four inches beyond the manufacturer's specifications, it must be tested to verify that it can withstand the lateral standard established by the Director of the Division of Motor Vehicles.

(b) For testing passenger or utility type vehicles the standard is 1.1 gravitational force or more.

(c) For testing pickup trucks the standard is 1.1 gravitational force or more.

(d) Vehicles that have not been raised more than four inches may be approved provided they comply with the standards set forth at N.J.A.C. 13:20-37.2.

13:20-37.4 Testing

Tests shall be conducted by the Division of Motor Vehicles at sites to be designated by the Director using the procedures and equation set forth at N.J.A.C. 13:20-37.5.

13:20-37.5 Procedure for testing modified vehicles

(a) The track width of the front and rear axles shall be measured from the centers of the tread of the outermost tires on the same axle. The front track width shall be

added to the rear track width and the sum shall be divided by two to give the average track width.

(b) The side to side weight distribution shall be calculated with the vehicle empty on level ground. The distribution shall not exceed 45 percent/55 percent as set forth in N.J.A.C. 13:20-37.2.

(c) One side of the vehicle should be raised to a static relative angle of 15 degrees a $\frac{1}{2}$ degrees from horizontal.

(d) The weight of the vehicle shall be measured on the unraised side.

(e) The maximum permissible weight on the unraised side is 62.4 percent of the total vehicle weight multiplied by twice the unraised side's weight percentage as determined in (b) above.

13:20-37.6 Certificate of approval

The Director may issue a certificate of approval upon the motor vehicle's compliance with the requirements set forth in this subchapter.

13:20-37.7 Denied or revocation of approval

Upon notice and an opportunity for a hearing pursuant to the Administrative Procedure Act, N.J.S.A. 52:14B-1 et seq., and the Uniform Administrative Rules of Practice, N.J.A.C. 1:1-1 et seq., the Director shall deny any application for a certificate of approval or revoke or suspend any certificate of approval issued under this subchapter for any failure to comply with or failure to continuously remain in compliance with any of the standards or requirements set forth in this subchapter.

SUBCHAPTER 38. DIMENSIONAL STANDARDS FOR AUTOMOBILE TRANSPORTERS

Source and Effective Date

R.1985 d.23, effective February 4, 1985.
See: 16 N.J.R. 3176(a), 17 N.J.R. 313(b).

13:20-38.1 Purpose

The purpose of this subchapter is to conform the rules of this State to the national policy governing truck size as set forth in the Federal "Surface Transportation Assistance Act of 1982," Pub.L. 97-424 (49 App. U.S.C. § 2311), as amended, and the regulations promulgated pursuant to that Federal law by establishing dimensional standards for automobile transporters that are in compliance with Federal standards contained in 23 C.F.R. § 658.13, revised as of February 1, 1991. The purpose of this subchapter is also to facilitate interstate commerce on the National Network of highways that can safely and efficiently accommodate the automobile

transporters authorized by the "Surface Transportation Assistance Act of 1982."

Repeal and New Rule, R.1993 d.380, effective August 2, 1993.
See: 25 N.J.R. 1342(a), 25 N.J.R. 3504(a).
Section was "Vehicle combination lengths."

13:20-38.2 Definitions

The following words and terms, when used in this subchapter, shall have the following meanings unless the context clearly indicates otherwise.

"Automobile transporter" means any vehicle combination designed and used specifically for the transport of assembled (capable of being driven) highway vehicles.

"Fullmount" means a smaller vehicle mounted completely on the frame of either the first or last vehicle in a saddle-mount combination.

"Saddlemount combination" means a combination of vehicles in which a truck or truck tractor tows one or more trucks or truck tractors, each connected by a saddle to the frame or fifth wheel of the vehicle in front of it. The saddle is a mechanism that connects the front axle of the towed vehicle to the frame or fifth wheel of the vehicle in front and functions like a fifth wheel kingpin connection. When two vehicles are towed in this manner the combination is called a double saddlemount combination. When three vehicles are towed in this manner, the combination is called a triple saddlemount combination.

"Stinger-steered combination" means an automobile transporter consisting of a truck tractor semitrailer wherein the fifth wheel is located on a drop frame located behind and below the rearmost axle of the power unit.

"Traditional automobile transporter" means an automobile transporter wherein the fifth wheel is located on the frame of the truck tractor over the rear axle(s) of said truck tractor.

Repeal and New Rule, R.1993 d.380, effective August 2, 1993.
See: 25 N.J.R. 1342(a), 25 N.J.R. 3504(a).
Section was "Load overhang automobile transporters."

13:20-38.3 Vehicle combination lengths; traditional automobile transporters; stinger-steered combination

(a) A traditional automobile transporter when operated on the highways of this State shall not exceed 65 feet in overall length, excluding the load.

(b) An automobile transporter consisting of a stinger-steered combination when operated on the highways of this State shall not exceed 75 feet in overall length, excluding the load.

Repeal and New Rule, R.1993 d.380, effective August 2, 1993.
See: 25 N.J.R. 1342(a), 25 N.J.R. 3504(a).

Section was "Number of vehicles; overall length."

13:20-38.4 Automobile transporter; load overhang

(a) Automobile transporters when operated on the highways of this State may have a load overhang of no more than three feet to the front and/or no more than four feet to the rear.

(b) Automobile transporters shall be exempt from the overhang standards set forth at N.J.A.C. 13:18-8.1.

New Rule, R.1993 d.380, effective August 2, 1993.
See: 25 N.J.R. 1342(a), 25 N.J.R. 3504(a).

13:20-38.5 Drive-away saddlemount vehicle transporter combinations; drive-away saddlemount with fullmount vehicle transporter combinations; overall length

(a) Drive-away saddlemount vehicle transporter combinations when operated on the highways of this State shall not exceed 75 feet in overall length.

(b) Drive-away saddlemount with fullmount vehicle transporter combinations when operated on the highways of this State shall not exceed 75 feet in overall length.

New Rule, R.1993 d.380, effective August 2, 1993.
See: 25 N.J.R. 1342(a), 25 N.J.R. 3504(a).

13:20-38.6 Application of Department of Transportation standards for 102-inch standard trucks to automobile transporters

Automobile transporters, drive-away saddlemount vehicle transporter combinations and drive-away saddlemount with fullmount transporter combinations having an overall length of the combination of vehicles, including load, or contents or any part or portion thereof, which exceed 62 feet shall be subject to the provisions of N.J.A.C. 16:32-3.2 (General provisions), N.J.A.C. 16:32-3.3 (Through routes for 102-inch standard trucks), and N.J.A.C. 16:32-3.4 (Access from through routes), as amended, which have been adopted by the Commissioner of Transportation.

New Rule, R.1993 d.380, effective August 2, 1993.
See: 25 N.J.R. 1342(a), 25 N.J.R. 3504(a).

SUBCHAPTER 39. SPECIAL REGISTRATION PLATES FOR NON-PROFIT ORGANIZATIONS

Source and Effective Date

R.1988 d.537, effective November 7, 1988.
See: 20 N.J.R. 2033(a), 20 N.J.R. 2788(a).

13:20-39.1 Purpose

(a) N.J.S.A. 39:3-27.35 et seq. provides for the issuance of special motor vehicle registration plates to members of non-profit community, alumni or service organizations in this State which have been approved by the Director. This subchapter establishes the following:

1. Standards and procedures by which an organization may request approval to have special motor vehicle registration plates prepared for its members who desire to apply for them;
2. Procedures regarding the certification of membership in good standing by an organization;
3. Standards and procedures by which an organization shall submit proof of its status as a non-profit organization to the Division;
4. Procedures by which an organization shall appoint an organization liaison who will act as a coordinator between the organization and the Division with regard to special motor vehicle registration plates;
5. Procedures by which an organization shall submit the organization's proposed special motor vehicle registration plate design to the Division for review and approval;
6. Standards and procedures which an approved organization must adhere to in order for its members in good standing to be able to apply for the organization's special motor vehicle registration plates;
7. Fees to be charged by the Division for special motor vehicle registration plates; and
8. Grounds upon which the Division may refuse to issue special motor vehicle registration plates to an individual, and the circumstances under which the Division may suspend or revoke such special plates.

Amended by R.1994 d.175, effective April 4, 1994.
Sec: 26 N.J.R. 331(a), 26 N.J.R. 1516(a).

13:20-39.2 Definitions

The following words and terms, when used in this subchapter, shall have the following meanings unless the context clearly indicates otherwise:

"Alumni organization" means a non-profit organization which requires its members to be either graduates, former students or benefactors of a specific post-secondary educational institution.

"Approved organization" means an organization in this State which has received a letter of approval from the Director indicating that its members are eligible to apply for special motor vehicle registration plates pursuant to this subchapter.

"Community organization" means a non-profit organization, other than an alumni or service organization as defined

in this subchapter, which performs some type of philanthropic community service and which, in the Director's discretion, qualifies for the issuance of special motor vehicle registration plates to its members in good standing who apply for same pursuant to this subchapter.

"Director" means the Director of the Division of Motor Vehicles in the Department of Law and Public Safety.

"Division" means the Division of Motor Vehicles in the Department of Law and Public Safety.

"Member" means any person who is a member in good standing of a non-profit community, alumni or service organization.

"Non-profit organization" means any community, alumni or service organization in this State that has been issued an approval letter by the United States Internal Revenue Service confirming its non-profit status.

"Organization" means any non-profit association, group or organization with a membership in good standing of at least 500 persons or, in the case of a service organization, with a membership in good standing of at least 175 persons, which qualifies as a non-profit organization.

"Organization liaison" means the representative appointed by an organization who will act as the organization's sole contact with the Division regarding special motor vehicle registration plates pursuant to this subchapter.

"Service organization" means a non-profit organization which the Director determines to have as its primary purpose the advancement of United States military veterans' causes and interests and/or the honoring of all or some veterans of any branch of the United States military service.

Amended by R.1994 d.175, effective April 4, 1994.
Sec: 26 N.J.R. 331(a), 26 N.J.R. 1516(a).

13:20-39.3 Qualifications for organization approval; final decision; right to suspend approval

(a) An organization seeking approval from the Division pursuant to this subchapter to have special motor vehicle registration plates prepared for its members in good standing who wish to apply for them shall:

1. Submit a written request to the Division seeking approval to have special plates prepared for its members who wish to apply for same;
2. Be composed of an active membership in good standing of at least 500 persons or, in the case of a service organization, an active membership in good standing of at least 175 persons;
3. Be a non-profit organization; and

4. Receive written approval from the Director as qualifying for special motor vehicle registration plates for its members in good standing who apply for same.

(b) The Director shall render the final decision as to whether or not an organization is approved for the issuance of special motor vehicle registration plates for its members pursuant to this subchapter in accordance with N.J.S.A. 39:3-27.37.

(c) The Director, in his or her discretion, may suspend approval of any organization which had previously been granted permission to obtain special motor vehicle registration plates on behalf of its members pursuant to this subchapter in accordance with N.J.S.A. 39:3-27.38.

Amended by R.1994 d.175, effective April 4, 1994.
See: 26 N.J.R. 331(a), 26 N.J.R. 1516(a).

13:20-39.4 Appointment of organization liaison

(a) Each organization shall appoint an organization liaison to represent that organization in any and all communications with the Division regarding special motor vehicle registration plates.

(b) The position of organization liaison shall be established at the highest administrative level within the organization.

(c) The organization shall submit to the Director, at the time of requesting approval to have special motor vehicle registration plates prepared for its members who wish to apply for same, the name, title and address of the organization liaison.

13:20-39.5 Certification of membership

(a) Upon seeking approval to have special plates prepared for its members who wish to apply for same pursuant to this subchapter, an organization shall submit to the Division a list of the legal names, addresses and current New Jersey registration plate numbers of its 500 or more members in good standing or, in the case of a service organization, of its 175 or more members in good standing, in alphabetical order by surname, who will be requesting the special motor vehicle registration plates if the Division approves the issuance of such plates.

(b) The certification of membership required pursuant to this section shall be provided at the organization's expense, shall be compiled and submitted on the organization's official letterhead, and shall be signed by the organization liaison.

(c) Certifications of membership submitted to the Division pursuant to this section are not public records and are not accessible for public examination pursuant to the "Right to Know Law" (N.J.S.A. 47:1A-1 et seq.).

Amended by R.1994 d.175, effective April 4, 1994.

See: 26 N.J.R. 331(a), 26 N.J.R. 1516(a).

13:20-39.6 Non-profit status

(a) Upon seeking approval to have special plates prepared for its members who wish to apply for same pursuant to this subchapter, an organization shall submit to the Division proof that it is a non-profit organization and such other information as the Division may require.

(b) To prove its non-profit status, an organization shall submit to the Division a photocopy of the approval letter issued to the organization by the United States Internal Revenue Service which confirms the organization's status as non-profit, and shall certify by affidavit that the photocopy is of the authentic document issued by the United States Internal Revenue Service to that organization.

(c) An organization shall provide a copy of its charter to the Division upon seeking approval to have special plates prepared for its members who wish to apply for same. The charter shall indicate the organization's lawful purpose.

13:20-39.7 Notification of organization approval

The Director will notify each organization by letter as to whether or not it has been approved for the issuance of special motor vehicle registration plates to its members in good standing who wish to apply for same pursuant to this subchapter.

13:20-39.8 Plate design

(a) An organization, through its designated organization liaison, shall submit to the Division a special motor vehicle registration plate prototype design which indicates the name or initials that the organization wishes to appear at the bottom of the special motor vehicle registration plate and the logotype, if any, that the organization wishes to appear on the special motor vehicle registration plate.

(b) The Director shall make the final determination pursuant to this subchapter as to:

1. The use, arrangement and size of an approved organization's name on the special motor vehicle registration plates;
2. Any initials that are to appear at the bottom of the special motor vehicle registration plates; and
3. The use, arrangement and size of an approved organization's desired logotype on the special motor vehicle registration plates.

(c) An approved organization will be notified whether its plate design has been approved through a letter from the Director to the organization liaison.

13:20-39.9 Fees; plate ordering; authenticity of membership

(a) Fees for special motor vehicle registration plates pursuant to this subchapter shall be as follows:

1. For members of an approved non-profit community organization, \$25.00 per each set of plates;
2. For members of an approved non-profit alumni organization, \$50.00 per each set of plates; and
3. For members of an approved non-profit service organization, \$15.00 per each set of plates.

(b) The initial order for special motor vehicle registration plates submitted to the Division by an approved organization on behalf of its members applying for such plates pursuant to this subchapter shall be for no less than 500 members of the organization in good standing or, in the case of a service organization, for no less than 175 members of the organization in good standing. The initial order shall be accompanied by a non-refundable fee representing the total cost of the initial order, which shall be determined by multiplying the number of sets of plates being ordered by the applicable fee for each set of such plates set forth in (a) above.

(c) Once an approved organization has an approved plate design, each organization member who wishes to apply for special motor vehicle registration plates shall be furnished an application by the organization liaison. The applicant shall complete the application in its entirety, and submit it, together with the applicable fee set forth in (a) above, to the organization liaison.

(d) The organization liaison shall authenticate each member's application for that organization's special motor vehicle registration plates by certifying on the application that the applicant is a member in good standing of the organization.

(e) The organization liaison shall thereafter submit the special plate applications to the Division together with the applicable fee for each set of such plates set forth in (a) above. The initial order of special motor vehicle registration plates pursuant to this subchapter shall be in accordance with (b) above.

(f) The Division, upon approval of an individual member's application, will mail the special motor vehicle registration plates and replacement certificate of registration bearing the new registration plate number to the applicable member.

(g) Upon receipt of the special motor vehicle registration plates and replacement certificate of registration by an organization member, that member must surrender his or her replaced license plates within 10 days to the Division at any motor vehicle agency or State operated motor vehicle inspection station or by mail to:

Division of Motor Vehicles
CN 403
Trenton, New Jersey 08666-0403

Amended by R.1994 d.175, effective April 4, 1994.
See: 26 N.J.R. 331(a), 26 N.J.R. 1516(a).

13:20-39.10 Denial, suspension or revocation

(a) Special motor vehicle registration plates shall not be issued pursuant to this subchapter to any person who:

1. Has been convicted of a violation of either N.J.S.A. 39:4-50 or N.J.S.A. 39:4-96;
2. Has been convicted of a violation of N.J.S.A. 2C:11-5;
3. Has had a suspension or revocation of driving privileges in effect in this State at any time within the two year period next preceding the date of application for such plates.

(b) Special motor vehicle registration plates shall not be issued pursuant to this subchapter for any motorcycle or commercially registered vehicle, nor for any vehicle which is not registered in the State of New Jersey.

(c) Any cause for which issuance of special motor vehicle registration plates pursuant to this subchapter may be denied which arises subsequent to the issuance of such plates shall also be cause for the suspension or revocation of such plates.

(d) A material misstatement of fact on an application for special motor vehicle registration plates submitted pursuant to this subchapter shall be cause for suspension or revocation of such plates.

(e) Any person who has been issued special motor vehicle registration plates pursuant to this subchapter which identify that person as a member of an approved organization shall surrender such plates to the Division together with the corresponding registration certificate within 30 days of that person's resignation, removal or termination from membership in such organization. The failure to so surrender such plates shall be cause for the suspension or revocation of such plates.

(f) The organization liaison shall notify the Division of Motor Vehicles in writing of any person who has been issued special motor vehicle registration plates pursuant to this subchapter and who subsequently resigns or is removed or terminated from membership in the approved organization. The notification required by this subsection shall be supplied to the Division within 30 days of the former organization member's resignation, removal or termination of membership in the approved organization, and shall

specify the date of the former member's resignation, removal or termination.

SUBCHAPTER 40. REFLECTORIZED REGISTRATION PLATES

Authority

P.L. 1989, c.202, § 2 (N.J.S.A. 39:3-33.9).

Source and Effective Date

R.1990 d.322, effective June 18, 1990.
Sec: 22 N.J.R. 1230(b), 22 N.J.R. 1940(b).

13:20-40.1 Additional annual fee

For purposes of P.L. 1989, c.202, § 2, in addition to an annual motor vehicle registration fee, the Division of Motor Vehicles shall charge an additional annual fee of \$0.40.

SUBCHAPTER 41. PERSIAN GULF WAR COMMEMORATIVE LICENSE PLATES

Authority

P.L.1991, c.264, § 1.

Source and Effective Date

R.1992 d.20, effective January 6, 1992.
Sec: 23 N.J.R. 2916(a), 24 N.J.R. 108(a).

13:20-41.1 Definition

The following words and terms, when used in this subchapter, shall have the following meanings unless the context clearly indicates otherwise:

"Division" means the Division of Motor Vehicles in the Department of Law and Public Safety.

"Nonprofit organization" means:

1. Any nonprofit organization dedicated to celebrating or commemorating the Persian Gulf War or aiding the participants or their families; or
2. Any nonprofit organization dedicated to establishing or maintaining a memorial to any war.

13:20-41.2 Fees

(a) The Division of Motor Vehicles shall charge a fee of \$3.00 per plate for Persian Gulf War commemorative license plates which it issues to nonprofit organizations pursuant to subsection (a) of section 1 of P.L. 1991, c.264. The commemorative license plates shall be issued by the Division only in multiples of 50.

(b) Nonprofit organizations which are issued Persian Gulf War commemorative license plates by the Division of Motor Vehicles pursuant to subsection (a) of section 1 of P.L. 1991, c.264 may sell such plates at a fee of \$10.00 per plate up to and including January 31, 1992, and not more than \$10.00 per plate thereafter.

13:20-41.3 Display

(a) Persian Gulf War commemorative license plates may be displayed on a New Jersey registered vehicle in accordance with subsection (b) of section 1 of P.L. 1991, c.264 and this subchapter from October 1, 1991 until April 1, 1992.

(b) The commemorative license plate shall be mounted on the front of the New Jersey registered vehicle at the same location as the regular front license plate, which shall be removed from the vehicle immediately prior to the mounting of the commemorative license plate. The regular front license plate shall remain mounted on those vehicles which do not display the commemorative license plate.

(c) After the last day during which the commemorative license plate may be displayed on a vehicle pursuant to subsection (b) of section 1 of P.L. 1991, c.264, the commemorative license plate may no longer be displayed in place of the regular front license plate, and the regular front license plate shall be immediately re-mounted on the front of the vehicle at the same location where it had previously been mounted.

13:20-41.4 Complaints; investigations

The Division shall, through its employees during regular business hours, be available to receive complaints from the public regarding the sale of Persian Gulf War commemorative license plates to the public pursuant to P.L. 1991, c.264 and this subchapter. The Division may conduct such investigations into the sale of the commemorative license plates as it deems necessary and proper.

SUBCHAPTER 42. PURPLE HEART EMBLEMS ON LICENSE PLATES

Authority

P.L. 1991, c.232, § 2.

Source and Effective Date

R.1992 d.168, effective April 6, 1992.
Sec: 24 N.J.R. 219(a), 24 N.J.R. 1365(a).

13:20-42.1 Use

A person who is an active member of the Military Order of the Purple Heart may, pursuant to P.L. 1991, c.232 and this subchapter, affix a purple heart emblem to a New Jersey purple heart license plate issued in accordance with N.J.S.A. 39:3-27.35 et seq. for a motor vehicle owned or leased by that member. Such an emblem may only be affixed to a New Jersey purple heart license plate.

13:20-42.2 Design

The purple heart emblem to be affixed to a purple heart license plate as set forth in N.J.A.C. 13:20-42.1 shall be of a design similar to that set forth in 32 CFR § 578.14(b), and shall be no larger in size than the replica of the purple heart which is already embossed on the purple heart license plate.

13:20-42.3 Materials

The purple heart emblem to be affixed to a purple heart license plate as set forth in N.J.A.C. 13:20-42.1 shall be made of reflectorized material.

13:20-42.4 Placement

The purple heart emblem to be affixed to a purple heart license plate as set forth in N.J.A.C. 13:20-42.1 shall be placed upon the replica of the purple heart which is already embossed on the license plate, and shall not obscure or cover any portion of the letters or numbers which appear on the license plate.

**SUBCHAPTER 43. ENHANCED MOTOR
VEHICLE INSPECTION AND
MAINTENANCE PROGRAM**

Authority

P.L. 1995, c.112, N.J.S.A. 39:2-3, 39:3-43, 39:8-4.1, 42 U.S.C. § 7401 et seq. and 40 C.F.R. § 51.350 et seq.

Source and Effective Date

R.1995 d.528, effective August 28, 1995.
See: 27 N.J.R. 2777(a), 27 N.J.R. 3820(a).

Subchapter Historical Note

Subchapter 43, Enhanced Motor Vehicle Inspection and Maintenance Program, was adopted as Emergency New Rules by R.1995 d.410, effective June 29, 1995, to expire August 28, 1995. See: 27 N.J.R. 2777(a). The concurrent proposal of Subchapter 43 was adopted as R.1995 d.528, effective August 28, 1995. See: Source and Effective Date. See, also, section annotations.

13:20-43.1 Definitions

The following words and terms, when used in this subchapter, shall have the following meanings, unless the context clearly indicates otherwise:

“Certificate of approval” means an inspection sticker issued by the Division certifying that a motor vehicle complies with the requirements of Title 39 and Title 26 of the Revised Statutes, this subchapter, and N.J.A.C. 7:27 and 7:27B regarding the inspection of motor vehicles.

“Certificate of waiver” means an inspection sticker evidencing that a vehicle has successfully passed a safety inspection but that the requirements of compliance with this subchapter and the rules adopted by the Department of Environmental Protection pertaining to emission inspection

standards have been waived by the Division for the particular inspection cycle for which the waiver is granted.

“Certified configuration” means a vehicle-engine-chassis design for light-duty gasoline-fueled vehicles and light-duty gasoline-fueled trucks certified by either of the following agencies as meeting the applicable emission standards for motor vehicles manufactured in a given model year:

1. EPA for model year 1968 or for a more recent model year; or
2. California Air Resources Board for model year 1966 or for a more recent model year.

“Collector motor vehicle” means a motor vehicle, not otherwise qualified for designation as an “historic vehicle,” or “street rod,” which was either: originally manufactured as a restricted issue make or model, or in a sufficiently limited quantity; or at the time of qualification for designation exists in such limited numbers; either one or the other or both of the above, according to any generally recognized compilation of motor vehicle statistical information on file with, or supplied by the owner to the Division, as may be accepted by the Director in his or her discretion, so as to establish it as a unique commodity having a current monetary value in excess of similar make and model vehicles with routine manufacture and distribution patterns, and, further, that is not driven in excess of 2,000 miles per year, and is covered by limited use motor vehicle insurance.

“Department” means the Department of Environmental Protection in the State of New Jersey.

“Director” means the Director of the Division of Motor Vehicles in the Department of Transportation in the State of New Jersey.

“Division” means the Division of Motor Vehicles in the Department of Transportation in the State of New Jersey.

“Emission control system” means a device or equipment installed on a motor vehicle by the manufacturer for the purpose of controlling air contaminants emitted from the motor vehicle or motor vehicle engine, including devices or equipment integral with but not limited to exhaust emission control systems, fuel evaporation control systems, crankcase emission control systems, and associated devices or systems which control or monitor the function of these devices or systems.

“EPA” means the United States Environmental Protection Agency.

“Federal Clean Air Act” means the Federal “Clean Air Act,” 42 U.S.C. §7401 et seq., and any subsequent amendments or supplements to that act.

“Federal test procedure” means a chassis dynamometer test which employs varying speeds and loads, developed by the Federal Environmental Protection Agency for purposes of measuring motor vehicle exhaust emissions.

“Fleet” means 10 or more motor vehicles.

“Gasoline-fueled” means powered by a hydrocarbon fuel other than diesel fuel, including, but not limited to, gasoline, natural gas, liquified petroleum gas, and propane, and also powered by alcohol fuels and hydrocarbon-alcohol fuel blends.

“Gross vehicle weight rating (GVWR)” means the value specified by the manufacturer as the maximum loaded weight of a single or combination (articulated) vehicle.

“Inspector” means an individual who is licensed by the Division to perform motor vehicle emission inspections.

“Light-duty gasoline-fueled truck” means a gasoline-fueled motor vehicle that has a GVWR of 8,500 pounds or less, a vehicle curb weight of 6,000 pounds or less, and a basic frontal area of 45 square feet or less, and that is:

1. Designed primarily for the transportation of property or more than 12 passengers; or
2. Available with special features enabling off-street or off-highway operation and use.

“Light-duty gasoline-fueled vehicle” means a gasoline-fueled motor vehicle that has a GVWR of 8,500 pounds or less, is designed primarily for use as a passenger car or is a passenger car derivative and is capable of seating 12 or fewer passengers.

“Loaded-mode (dynamometer-based) emission test” means the ASM 5015 emission test.

“Low mileage vehicle” means a vehicle that is driven less than 10,000 miles during the biennial inspection period.

“Model year” means, with respect to a motor vehicle, the year in which the motor vehicle is considered to have been manufactured. If the manufacturer establishes an annual production period, designation of the year shall be based on the annual production period during which the manufacturer begins production of the motor vehicle. When such annual production period falls within one calendar year, the model year attributed to the motor vehicle shall be that calendar year. When such annual production period continues from one calendar year into the next, the model year attributed to the motor vehicle shall be the latter calendar year (for example, a motor vehicle produced in an annual production period that continues from 1994 to 1995 shall be considered as being produced in the 1995 model year). If the manufacturer establishes no annual production period, a motor vehicle’s model year shall be the calendar year in which the manufacturer begins production of that motor vehicle. If a motor vehicle is manufactured in two or more stages, the model year of such motor vehicle shall be based on the date of completion of the chassis. In case of any dispute, the Director shall have sole discretion to determine the model year of a vehicle for purposes of this subchapter. For purposes of this subchapter, the Director may, in his or her discretion, determine that “model year” means the model year designated for the motor vehicle as contained in the vehicle identification number for such vehicle.

“Motor vehicle” means all vehicles propelled otherwise than by muscular power, excepting such vehicles as run only upon rails or tracks and motorized bicycles.

“Motor vehicle emission repair facility” means any person, partnership or corporation registered by the Division to engage in the business of performing emission-related repairs on motor vehicles that have failed an emission inspection required by this subchapter and which repairs may qualify for consideration in determining whether a certificate of waiver may be granted.

“Official inspection facility” means a test-only inspection facility that is operated by the Division or that the State Treasurer has contracted for pursuant to section 4 of P.L. 1995, c.112.

“Omnibus” means all motor vehicles used for the transportation of passengers for hire, except commuter vans and vehicles used in ridesharing arrangements and school buses, if the same are not otherwise used in the transportation of passengers for hire.

“Primary emission control component” means the air pump, oxygen sensor, catalytic converter, positive crankcase ventilation (PCV) valve and exhaust gas recirculation (EGR) valve.

“Private inspection facility” means any person, partnership or corporation licensed by the Division pursuant to N.J.A.C. 13:20-44 to perform the motor vehicle inspections required by this subchapter.

“Remote sensing device” means an apparatus which remotely monitors motor vehicle emissions from an on-road, roadside, or other location.

“State” means a state of the United States or the District of Columbia.

“Working order” (Reserved).

13:20-43.2 Inspection requirements for motor vehicles; exempt motor vehicles; designation of collector motor vehicles

(a) Except as otherwise provided in (b) below, all motor vehicles, regardless of model year or fuel type, which are registered or required to be registered in New Jersey and all fleet motor vehicles which are primarily operated in New Jersey shall be inspected in accordance with this subchapter and the applicable emission standards adopted by the Department of Environmental Protection at N.J.A.C. 7:27 and 7:27B. It shall be the responsibility of the owner or lessee of any motor vehicle primarily operated in New Jersey but which is registered in another jurisdiction to have such vehicle inspected in the state or jurisdiction of registration or in this State.

(b) The following motor vehicles, some of which may be subject to inspection under other provisions of law or regulation, shall be exempt from the inspection requirements of this subchapter:

1. Historic motor vehicles registered pursuant to N.J.S.A. 39:3-27.4;
2. Collector motor vehicles;
3. Motorcycles;
4. Motorized bicycles;
5. Farm tractors and traction equipment registered pursuant to N.J.S.A. 39:3-24;
6. Farm machinery and implements registered pursuant to N.J.S.A. 39:3-24;
7. Fire trucks having a GVWR of more than 8,500 pounds;
8. In-transit construction equipment registered pursuant to N.J.S.A. 39:4-30;
9. Diesel-fueled motor vehicles, other than omnibuses and school buses, having a GVWR of more than 8,500 pounds that are required to be inspected by the owner of the vehicle;
10. Omnibuses having a seating capacity of 16 passengers or more and which are subject to inspection by the New Jersey Department of Transportation; and
11. Tactical military vehicles operated on Federal installations within this State.

(c) To qualify for designation as a "collector motor vehicle" the owner or lessee of a vehicle shall submit an application in the form specified by the Division which provides evidence of the following:

1. The vehicle is not currently qualified for designation as an "historic motor vehicle," as provided at N.J.S.A. 39:3-27.3 et seq., and any rules promulgated pursuant thereto, or as a "street rod," as provided at N.J.S.A. 39:3-27.27, and any rules promulgated pursuant thereto;
2. The vehicle is driven fewer than 2,000 miles per year, including during the immediate past inspection cycle for the vehicle; and
3. The vehicle currently qualifies for, and is covered by, motor vehicle insurance coverage of a kind intended for limited use collector motor vehicles; and either,
 - i. Proof that the vehicle was originally manufactured as a restricted issue make or model, or in a sufficiently limited quantity, according to any generally recognized compilation of motor vehicle statistical information on file with, or supplied by the owner or lessee to the Division, as may be accepted by the Director in his or her discretion, so as to establish the vehicle as a unique commodity having a current mone-

tary value in excess of similar make and model vehicles with routine manufacture and distribution patterns; or

- ii. Proof that at the time of qualification for designation as a "collector motor vehicle" that the make and model of such vehicles exist in such limited numbers, according to any generally recognized compilation of motor vehicle statistical information on file with, or supplied by the owner or lessee to the Division, as may be accepted by the Director in his or her discretion, so as to establish the vehicle as a unique commodity having a current monetary value in excess of similar make and model vehicles with routine manufacture and distribution patterns.

(d) The Director or his or her designee shall verify the odometer reading of a "collector motor vehicle" and may require that such vehicle be equipped with an odometer lock.

(e) The owner of any motor vehicle qualifying as a "collector motor vehicle" shall be eligible to purchase from the Division a distinctive windshield sticker, of a design and dimensions to be approved by the Director, said sticker to be affixed in lieu of a certificate of approval, by an authorized representative of the Division, indicating that said vehicle is a "collector motor vehicle" that is exempt from the inspection requirements of N.J.S.A. 39:8-1. The windshield sticker shall be valid for the inspection test cycle.

(f) The owner or lessee of a "collector motor vehicle" shall make application to the Division for the renewal of the windshield sticker prior to expiration of the inspection test cycle. The renewal application shall at a minimum be accompanied by proof that the vehicle is covered by motor vehicle insurance coverage of a kind intended for limited use collector motor vehicles.

(g) The cost of said sticker shall be \$25.00 for the initial inspection test cycle and \$10.00 for the renewal of said sticker for inspection test cycles thereafter.

13:20-43.3 Inspection facilities

A motor vehicle subject to inspection shall have the inspection performed at an official inspection facility operated by, or under contract with, the Division or at a private inspection facility licensed by the Division, except that an initial emission inspection of a motor vehicle which is more than four years old shall not be performed by a private inspection facility unless it has a GVWR of more than 8,500 pounds. A motor vehicle having a GVWR of 8,500 pounds or less which fails an initial emission inspection over two consecutive test cycles shall be reinspected at an official inspection facility following the second initial emission test failure.

13:20-43.4 Federal motor vehicles

(a) Motor vehicles that are operated on Federal installations located within New Jersey and motor vehicles operated by Federal government agencies in this State shall be inspected in accordance with this subchapter and the emission standards adopted by the Department of Environmental Protection at N.J.A.C. 7:27 and 7:27B. Each Federal installation and each Federal government agency shall provide to the Division a report of motor vehicles operated on the Federal installation or maintained as part of the Federal fleet in this State. The report shall include:

1. The vehicle identification number (VIN), including VIN prefix, for the motor vehicle;
2. The vehicle model year, make, color, body type and weight class;
3. The GVWR for the motor vehicle;
4. The license plate number issued by the Federal government agency for the motor vehicle;
5. The name and address of the Federal government agency supplying the report; and
6. The name, business address, and telephone number of the person preparing the report.

(b) The reports in (a) above shall be provided to the Division in such format and at such times as the Division shall determine. A per vehicle inspection fee of \$35.00 shall be paid to the Division for the inspection of Federal motor vehicles under this section. Payment of the inspection fee shall be made and shall accompany the reports submitted to the Division under this section.

(c) The Division shall provide to the operator of a Federally-plated or numbered motor vehicle which is presented for inspection in this State a report of inspection conducted under (a) above which shall include:

1. The VIN for the motor vehicle;
2. The license plate number issued by the Federal government agency for the motor vehicle;
3. HC results;
4. O results;
5. CO₂ results;
6. NO_x results;
7. O₂ results;
8. Pressure test results;
9. Purge test results; and
10. Safety inspection results.

(d) All motor vehicles owned, leased or operated by civilian or military personnel on Federal installations in New Jersey, whether such vehicles are registered in this State or in another jurisdiction, shall be inspected in accordance with this subchapter and the emission standards adopted by the Department of Environmental Protection at N.J.A.C. 7:27 and 7:27B. This inspection requirement shall not apply to visiting agency, employee or military personnel vehicles so long as such visits do not exceed 60 calendar days per year.

13:20-43.5 Motor vehicles registered in other states

(a) Owners, lessees or operators of motor vehicles registered in other jurisdictions may present their motor vehicles for inspection in this State. The inspection shall be in accordance with this subchapter and the emission standards adopted by the Department of Environmental Protection at N.J.A.C. 7:27 and 7:27B.

(b) Owners, lessees or operators of the motor vehicles specified in N.J.A.C. 13:20-43.4(d) and (a) above that are not registered in New Jersey, or those motor vehicles specified in N.J.A.C. 13:20-43.4(a) that are not listed on the report required to be submitted by that subsection, shall make application for inspection at such locations as are specified by the Division and shall pay to the Division a per vehicle inspection fee of \$35.00 prior to presenting the vehicle for inspection. The inspection application shall contain the following:

1. The VIN, including VIN prefix, for the motor vehicle;
2. The vehicle model year, make, color, body type and weight class;
3. The GVWR for the motor vehicle;
4. The license plate number for the motor vehicle;
5. The name of the state in which the vehicle is registered; and
6. The name and address of the owner of the motor vehicle.

(c) The Division shall provide to the operator of a motor vehicle which is presented for inspection in this State a report of inspection conducted under N.J.A.C. 13:20-43.4(d) or (a) above.

(d) The owner or lessee of a motor vehicle shall transmit a report of inspections conducted under N.J.A.C. 13:20-43.4(d) or (a) above to the state of registration which shall include:

1. The VIN for the motor vehicle;
2. The license plate number issued for the motor vehicle;
3. The name of the state in which the vehicle is registered;

4. HC results;
5. CO results;
6. CO₂ results;
7. O₂ results;
8. NO_x results;
9. Pressure test results;
10. Purge test results; and
11. Safety inspection results.

13:20-43.6 Fleet motor vehicles

All fleet motor vehicles, including those that are available for lease or rent, which are registered in this State, or are registered in another state and primarily operated in New Jersey, shall be inspected in accordance with this subchapter and the emission standards adopted by the Department of Environmental Protection at N.J.A.C. 7:27 and 7:27B. A fleet vehicle shall be inspected at an official inspection facility or by a licensed private inspection facility, except that a licensed private inspection facility shall not perform an initial emission inspection of a vehicle that is more than four years old. The owner or lessee of fleet motor vehicles may apply for and be licensed by the Division as a private inspection facility in accordance with chapter 8 of Title 39 of the Revised Statutes and N.J.A.C. 13:20-44. A motor vehicle having a GVWR of 8,500 pounds or less which fails an initial emission inspection over two consecutive test cycles shall be reinspected at an official inspection facility following the second initial emission test failure.

13:20-43.7 Test frequency

Motor vehicles subject to inspection pursuant to this subchapter shall be inspected on a biennial basis, except as otherwise provided by law or regulation. Whenever a vehicle previously registered in a foreign jurisdiction is registered in this State, the vehicle shall be presented for inspection within 30 days from the date of issuance of a certificate of registration for the vehicle. Following completion of the inspection of a vehicle which was previously registered in a foreign jurisdiction, the vehicle shall be inspected on a biennial basis, except as otherwise provided by law or regulation.

13:20-43.8 Tests for emissions

(a) A loaded-mode (dynamometer-based) test shall be conducted in accordance with N.J.A.C. 7:27-15.5 on all gasoline-fueled motor vehicles with model years 1968 and later having a GVWR of 8,500 pounds or less; provided, however, no such test shall be required for any full-time four-wheel drive vehicle regardless of weight class, for a low mileage vehicle, for a motor vehicle which is operated by a handicapped person and which has been modified so that such vehicle is fully controlled by specially designed mechanical devices for the handicapped, or for any other vehicle

having a particular design characteristic which makes its operation on a dynamometer either impractical or hazardous, as shall be determined in the discretion of the Director. In such exceptional cases an idle emission test, conducted in accordance with N.J.A.C. 7:27-15.5 and 7:27B-4.5(b), shall be administered. All motor vehicles which are subject to a loaded-mode (dynamometer-based) test shall not exceed the emission levels established at N.J.A.C. 7:27 for such vehicles by the Department of Environmental Protection for hydrocarbons (HC), carbon monoxide (CO), or oxides of nitrogen (NO_x).

(b) An idle emission test shall be conducted in accordance with N.J.A.C. 7:27-15.5 and 7:27B-4.5(b) on all gasoline-fueled motor vehicles with model years 1967 and earlier, all gasoline-fueled motor vehicles having a GVWR greater than 8,500 pounds, all low mileage vehicles with model years 1980 and earlier and all such motor vehicles as set forth in (a) above that are specifically exempted from the requirement of a loaded-mode (dynamometer-based) test. A 2,500 RPM idle emission test shall be conducted in accordance with N.J.A.C. 7:27-15.5 and 7:27B-4.5(b) on all low mileage vehicles with model years 1981 and later, and on all motor vehicles that are operated by handicapped persons and have been modified so that such vehicles are fully controlled by specially designed mechanical devices for the handicapped. All motor vehicles which are subject to an idle test shall not exceed the emission levels established at N.J.A.C. 7:27 for such vehicles by the Department of Environmental Protection for hydrocarbons (HC) and carbon monoxide (CO).

(c) An evaporative system purge test shall be conducted on all post-1974 model year light-duty gasoline-fueled motor vehicles and light-duty gasoline-fueled trucks that were originally equipped with an evaporative emission control system when manufactured provided such vehicles are subject to a loaded-mode (dynamometer-based) test, unless a particular design characteristic of the vehicle makes it impractical to administer such test. All motor vehicles which are subject to the purge test shall meet the standards for such test established by the Department of Environmental Protection at N.J.A.C. 7:27-15 and 7:27B-4. The evaporative system purge test shall not be conducted on full-time four-wheel drive vehicles or a vehicle which has a particular design characteristic which makes its operation on a dynamometer either impractical or hazardous.

(d) An evaporative system integrity (pressure) test shall be conducted on all post-1974 model year light-duty gasoline-fueled motor vehicles and light-duty gasoline-fueled trucks that were originally equipped with an evaporative emission control system when manufactured, unless a particular design characteristic of the vehicle makes it impractical to administer such test. Vehicles subject to the pressure test shall meet the standards for such test established by the Department of Environmental Protection at N.J.A.C. 7:27-15 and 7:27B-4.

(e) An inspection conducted by a licensed private inspection facility shall include an inspection for the presence of the catalytic converter on all light-duty gasoline-fueled vehicles and light-duty gasoline-fueled trucks which were manufactured with a catalytic converter as original equipment. The inspection shall be conducted in accordance with N.J.A.C. 7:27-15.5 and 7:27B-4.8. Motor vehicles shall fail inspection if the catalytic converter was a part of the original certified configuration for the motor vehicle and the catalytic converter is missing or disconnected. If it is found that the catalytic converter is modified or improperly connected, the vehicle shall fail inspection.

(f) A motor vehicle safety equipment inspection shall be conducted on all motor vehicles subject to inspection. The following safety equipment shall be subject to inspection:

1. Steering and suspension;
2. Glazing and vision obstruction;
3. Headlights;
4. Red rear lights;
5. Stop lights;
6. Turn signals;
7. Reflectors;
8. Horn;
9. Windshield wipers;
10. Wheels and tires;
11. Exhaust system;
12. Mirrors;
13. Service brake (operation and pedal reserve);
14. Parking brake;
15. Brake equalization;
16. Seat belts; and
17. Such other equipment, as an inspection discloses will affect the safe operation of the vehicle or present an imminent safety hazard to its occupants or the public.

(g) Each motor vehicle inspection conducted pursuant to this subchapter shall include an examination of the driver's license, motor vehicle registration certificate and insurance identification card.

13:20-43.9 Inspection reports; emission-related repair forms

(a) The operator of each motor vehicle shall be provided with a motor vehicle inspection report and inspection report supplement, if issued, upon completion of an inspection. The motor vehicle inspection report and inspection report supplement, if issued, shall include:

1. The inspection facility number;

2. The type of test(s) performed;
3. The date of the inspection;
4. The inspection serial number;
5. The inspection certificate number;
6. The vehicle model year, make, and body type;
7. The vehicle license plate number;
8. The fuel type;
9. The gross vehicle weight rating;
10. The vehicle identification number;
11. The vehicle odometer reading to the nearest 1,000 miles;
12. The category of inspection (that is, initial inspection, first reinspection, second reinspection, etc.);
13. The pass/fail result of applicable visual inspections;
14. Results of the evaporative system functional tests;
15. The type of vehicle preconditioning performed, if applicable;
16. Results of the safety inspection;
17. Emission inspection results and standards for the vehicle;
18. Instructions indicating that the report is to be returned to an official inspection facility or licensed private inspection facility upon reinspection;
19. A statement indicating the availability of warranty coverage as required in section 207 of the Federal Clean Air Act;
20. Instructions indicating that the motor vehicle must be repaired and returned to an official inspection facility or licensed private inspection facility and reinspected;
21. Instructions for waiver applicants;
22. Such advisory diagnostic information as may be made available;
23. Space to indicate repair by a registered motor vehicle emission repair facility;
24. Space to indicate the name, address, and registration number of the motor vehicle emission repair facility which performed the emission-related repair(s);
25. Space to indicate the cost of parts and labor for emission-related repair(s);
26. Space to indicate the emission-related repair(s) performed;
27. Space to indicate technician recommended repair(s) that were not performed; and
28. Other information as the Division may require to enable it to determine compliance with this subchapter.

(b) A registered motor vehicle emission repair facility shall provide all of the information on the motor vehicle inspection report and inspection report supplement, if issued, relating to emission-related repairs required by (a) above and shall present the completed motor vehicle inspection report and inspection report supplement, if issued, to the owner or lessee upon delivery of the repaired vehicle to such owner or lessee.

(c) The Division shall prescribe a Pre-inspection Repair Form for use by registered motor vehicle emission repair facilities for demonstrating that pre-inspection emission-related repairs have been performed by such facilities and shall contain all applicable information as set forth in (a)23 through 28 above. The Pre-inspection Repair Form may be used by a registered motor vehicle emission repair facility for demonstrating that post-inspection emission-related repairs have been performed by such facility only when the original motor vehicle inspection report or inspection report supplement, if issued, has been lost by the owner or lessee and has not been presented to the facility. The Pre-inspection Repair Form shall be completed and presented to the owner or lessee upon delivery of the repaired vehicle to such owner or lessee. No such Pre-inspection Repair Form shall be presented in blank to such owner or lessee or any other person; nor shall such form be furnished to such owner or lessee unless the vehicle identification number of the repaired vehicle is clearly printed or written in ink on the face of said form. The form prescribed by the Division pursuant to this subsection may be reprinted as needed by registered motor vehicle emission repair facilities. The forms, as reprinted by a registered repair facility, shall contain the registration number of such facility and each form shall contain a unique control number which corresponds to the sequential order in which such forms were reprinted, and any other information that the Director may require.

13:20-43.10 Reinspections

Motor vehicles that fail inspection shall be reinspected after the vehicle has been repaired or adjusted. The operator of a motor vehicle that exceeded the exhaust emission standards during the vehicle's inspection shall present the previously issued motor vehicle inspection report and inspection report supplement, if issued, or pre-inspection repair form (if applicable), which has been completed by a registered motor vehicle emission repair facility or by an owner possessing a nationally recognized certification who performed the emission-related repairs. All motor vehicles subject to a reinspection or that fail an on-road inspection under N.J.A.C. 13:20-43.14 for emission standards shall be subject to the separable portions of the inspection procedure for emissions for the vehicle model year (that is, functional testing and exhaust testing where applicable). Portions of the emission testing procedure shall be considered separable for purposes of this section if a failure on one portion does not affect the likelihood of passage or failure on any other portion of the testing procedure. If the motor vehicle passes the reinspection, the Division, or an authorized inspector, shall issue a certificate of approval for

the motor vehicle indicating compliance. If the motor vehicle fails to pass the reinspection, the Division, or an authorized inspector, shall issue a motor vehicle inspection report indicating non-compliance. If the motor vehicle fails the reinspection for an emission-related problem and the owner or lessee requests a waiver of compliance, the Division or its authorized representatives shall review the request and shall approve or deny the request in accordance with N.J.A.C. 13:20-43.13. Requests for waiver shall be presented at such locations as are designated by the Director and approved or denied only by such persons as designated by the Director.

13:20-43.11 Inspection certificates of approval; inspection rejection stickers

(a) A certificate of approval shall be issued for motor vehicles which meet safety and emission standards. The certificate of approval shall be affixed to the lower left corner of the windshield inside the passenger compartment of the motor vehicle.

(b) An inspection rejection sticker shall be issued for motor vehicles which fail to meet safety and/or emission standards. The inspection rejection sticker shall be affixed to the lower left corner of the windshield inside the passenger compartment of the motor vehicle. The owner or lessee of a motor vehicle which has failed inspection shall have the necessary repairs made and shall present the vehicle for reinspection no later than the last day of the calendar month following the calendar month in which the vehicle was due for inspection, except as otherwise provided at N.J.A.C. 13:20-7.2.

13:20-43.12 Inspection extensions

(a) A motor vehicle which is registered in New Jersey that cannot be presented for inspection in this State prior to the expiration of the certificate of approval or certificate of waiver issued for the vehicle shall be deemed to be in compliance with the inspection requirements of this State if the vehicle is presented for an inspection in the state in which it is temporarily located, provided that such inspection is performed in an enhanced I/M program. In order to avoid sanctions for failure to comply with the inspection requirements of this State, it shall be the responsibility of the owner or lessee of the vehicle to transmit to the Division proof that the vehicle has been inspected by another state's enhanced I/M program. Such proof shall consist of a report issued by the enhanced I/M program of such other state containing the license plate number or vehicle identification number of the vehicle inspected, the date and location of inspection, and the results of such inspection. If such proof has been submitted and a current registration has been issued for the vehicle, the Director or his or her designee may, for good cause shown, issue a letter extending the time period in which to have the vehicle inspected. The inspection extension shall be valid from its effective date to 30 days from the date upon which the owner or lessee returns the motor vehicle to New Jersey, but in no event shall the extension be valid for more than two years from its effective date.

(b) The owner or lessee of a motor vehicle registered in New Jersey which cannot be presented for inspection in this or another State prior to the expiration of the certificate of approval or certificate of waiver issued for the vehicle because it is temporarily located in a state or region that does not have an enhanced I/M program shall notify the Division of the date upon which the motor vehicle will be returned to New Jersey. If a current registration has been issued for the vehicle, the Director or his or her designee may, for good cause shown, issue a letter extending the time period in which to have the vehicle inspected. The inspection extension shall be valid from its effective date to 30 days from the date upon which the owner or lessee returns the motor vehicle to New Jersey, but in no event shall the extension be valid for more than two years from its effective date.

13:20-43.13 Waivers; criteria for issuance; denial of warranty form; repair receipt form; waiver valid for inspection cycle; waiver issuance

(a) A motor vehicle which fails to satisfy the applicable emission standards as set forth in the rules adopted by the Department of Environmental Protection at N.J.A.C. 7:27-15 and 7:27B-4 shall be eligible for a certificate of waiver if the following requirements are satisfied:

1. The vehicle has failed to pass a loaded-mode emission reinspection after all qualifying repairs have been completed;
2. The vehicle has passed an idle emission test conducted in accordance with N.J.A.C. 7:27-15.5 and 7:27B-4.5(b);
3. The vehicle has passed a safety inspection conducted in accordance with this subchapter;
4. The owner or lessee has provided written proof to the satisfaction of the Director that all available warranty repairs have been made to the motor vehicle or a written denial of warranty coverage from the manufacturer or authorized dealer in a form prescribed for such purpose by the Director;
5. Repairs were appropriate to the cause of the test failure;
6. Repairs were performed by a registered motor vehicle emission repair facility or by the owner of the vehicle, provided he or she possesses a nationally recognized certification for emission-related diagnosis and repairs. Any owner or lessee of a motor vehicle may perform emission-related repairs of primary emission control components; provided, that only the cost of parts incurred by the owner or lessee during the course of the repair of such components shall be applied toward the applicable waiver amount in (a)8 below;

7. Original repair receipts are submitted to the Division verifying that qualifying repairs have been performed; and

8. Prior to January 1, 1998, the owner or lessee has expended no less than the applicable amount specified at 40 C.F.R. §51.360(a)(6) for emission-related repairs of the motor vehicle excluding any repairs made under warranty coverage. Beginning on January 1, 1998, the owner or lessee has expended no less than the amount specified at 40 C.F.R. §51.360(a)(7) for emission-related repairs of the motor vehicle excluding any repairs made under warranty coverage.

(b) A waiver shall not be issued to a motor vehicle for tampering-related repairs. The cost of tampering-related repairs shall not be counted towards the cost limits in (a)8 above.

(c) A waiver shall not be issued to a motor vehicle which fails an evaporative system purge test or an evaporative system integrity (pressure) test if the cause for such failure is safety-related.

(d) A waiver shall expire at the end of the specific inspection cycle for which it was granted, after which the vehicle shall either pass inspection or qualify for issuance of another waiver pursuant to this section.

(e) The Director, or his or her designee, shall issue a certificate of waiver for those motor vehicles satisfying all the requirements of this section. The certificate of waiver shall be affixed to the lower left corner of the windshield inside the passenger compartment of the motor vehicle.

13:20-43.14 On-road inspections; scope; inspection procedures; criteria for selecting vehicles; procedures upon inspection failure

(a) On-road motor vehicle safety and emission inspection is intended to complement the safety and emission inspection otherwise required in the State of New Jersey by law or regulation.

(b) On-road inspection shall consist of a safety inspection, a visible smoke test, a tailpipe emission inspection, an inspection for the presence and integrity of the motor vehicle's catalytic converter, including a tap test thereof, an examination of the driver's license, motor vehicle registration certificate and insurance identification card, and such other tests as may be determined by the Director.

(c) On-road emission inspection procedures shall utilize the BAR 90 analyzer or such other emission inspection equipment approved by the Director after consultation with the Department of Environmental Protection in accordance with N.J.A.C. 7:27-15.5(f).

(d) On-road emission inspection shall be conducted using the emission inspection standards set forth in rules adopted by the Department of Environmental Protection at N.J.A.C. 7:27-15 and 7:27B-4.

(e) The Division shall use the following criteria in determining which motor vehicles shall be subjected to on-road safety and emission inspection:

1. Motor vehicles with an observable defect(s);
2. Motor vehicles without a certificate of approval;
3. Motor vehicles with an expired certificate of approval;
4. Motor vehicles with an expired inspection rejection sticker;
5. Motor vehicles without a registration plate(s) and/or registration plate insert(s);
6. Motor vehicles which fail to meet minimum emission standards as determined by a remote sensing device; or
7. Motor vehicles which correspond to a predetermined numerical sequence established by Division supervisory personnel for subjecting motor vehicles to on-road safety and emission inspection (for example, every fifth motor vehicle, every tenth motor vehicle, etc.).

(f) If a motor vehicle subject to on-road inspection fails to meet minimum safety and/or emission standards, an inspection rejection sticker shall be affixed to the lower left corner of the windshield inside the passenger compartment of the motor vehicle.

(g) The owner or lessee of a motor vehicle which has failed an on-road inspection shall have the necessary repairs made and present the vehicle for a complete reinspection within 30 days of the date of the on-road inspection rejection, except as otherwise provided at N.J.A.C. 13:20-7.2.

13:20-43.15 Recall compliance procedures; purpose; applicability; notice to owner; recall compliance form; transfer of ownership; denial and suspension of registration

(a) Owners and lessees of motor vehicles which are included in either a "Voluntary Emissions Recall" as defined at 40 C.F.R. §85.1902(d), or in a remedial plan determination made pursuant to section 207(c) of the Federal Clean Air Act, shall present such vehicles to the manufacturer or authorized dealer for emission-related repairs and shall comply with the procedures set forth in this section.

(b) Recall compliance procedures set forth in this section shall apply to all motor vehicles for which owner recall notification occurs after January 1, 1995.

(c) The EPA or an entity approved by the EPA shall provide the Division with a list of vehicle identification numbers with unresolved recalls.

(d) The Division shall provide written notice to an owner or lessee of a motor vehicle which is contained on an EPA list of vehicle identification numbers with unresolved recalls. The notice shall inform the owner or lessee of the following:

1. That the vehicle is subject to a recall notification;
2. That the vehicle must be presented to the manufacturer or authorized dealer for emission-related repairs; and
3. That proof of compliance with the recall notice must be submitted to the Division as a precondition to the Division's issuance of a certificate of approval for the vehicle.

(e) The Division shall prescribe a Recall Compliance Form for use in demonstrating recall compliance in accordance with this section. The Recall Compliance Form shall be provided to an owner or lessee with the written notice required under (d) above. The owner or lessee shall submit the Recall Compliance Form to the manufacturer or authorized dealer when he or she presents the vehicle for emission-related recall repairs. The manufacturer or authorized dealer shall be responsible for providing the information required on the Recall Compliance Form. The manufacturer or authorized dealer shall provide the owner or lessee with the completed Recall Compliance Form. The owner or lessee of the vehicle shall submit the Recall Compliance Form to the Division. The manufacturer or authorized dealer shall maintain a copy of the Recall Compliance Form in its files for a period of five years from the date of completion of the emission-related repairs. The manufacturer or authorized dealer shall make available the completed Recall Compliance Form upon the request of the Director or his or her designee.

(f) The Recall Compliance Form shall include the following:

1. The VIN, make, and model year of the vehicle;
2. The recall campaign number;
3. The date emission-related repairs were completed;
4. The name, address and telephone number of the authorized dealer completing the emission-related repairs; and
5. The dealer license number, if the authorized dealer completing the emission-related repairs is located in New Jersey.

(g) Except as otherwise provided in this section, the Division shall deny the issuance or renewal of the registration of a motor vehicle and shall suspend the registration of a motor vehicle if the owner or lessee has not filed or caused to be filed with the Division proof that recall emis-

sion-related repairs have been completed by the manufacturer or authorized dealer.

(h) The denial of the registration shall be effective on the first day following the expiration date of the vehicle's registration. The suspension of the registration shall be effective on the date specified by the Division in an order of suspension issued to the owner.

1. The Division shall not suspend a motor vehicle registration pursuant to this section if the owner has surrendered to the Division the registration certificate and registration plates issued thereto.

2. The Division shall not deny a motor vehicle registration pursuant to this section if the notice of unresolved recall required by (d) above is mailed or given to the owner or lessee of the vehicle in the six month period immediately preceding the expiration date of the motor vehicle's registration. If such notice is mailed or sent to the owner or lessee during the six month period and registration is issued or renewed by the Division, no further registration for that motor vehicle shall be issued or renewed unless proof of compliance with the recall notice is submitted to the Division.

13:20-43.16 Registration denial; suspension of registration; motor vehicles not inspected by registration expiration date; motor vehicles which have failed inspection and have not been presented for reinspection

(a) Except as otherwise provided in this section, the Division shall deny the issuance or renewal of the registration of a motor vehicle and shall suspend the registration of a motor vehicle if the owner or lessee has not presented the vehicle for inspection prior to the expiration of the certificate of approval or certificate of waiver issued for the vehicle. The Division shall not suspend a motor vehicle registration pursuant to this subsection if the owner or lessee complies with either of the following requirements:

1. Surrenders or causes to be surrendered to the Division the registration certificate and registration plates issued thereto within the period of time provided in the Division's notice; or

2. Presents or causes the vehicle to be presented for inspection within the period of time provided in the Division's notice.

(b) Except as otherwise provided in this section, the Division shall deny or suspend the registration of a motor vehicle if the owner or lessee has not presented the vehicle for reinspection prior to the expiration of the inspection rejection sticker issued for the vehicle after failure of inspection. The Division shall not suspend a motor vehicle registration pursuant to this subsection if the owner or lessee complies with either of the following requirements:

1. Surrenders or causes to be surrendered to the Division or its authorized agents the registration certificate and registration plates issued thereto within the period of time provided in the Division's notice; or

2. Presents or causes the vehicle to be presented for reinspection within the period of time provided in the Division's notice.

(c) The Division shall not issue a motor vehicle registration renewal application if the registration for the vehicle is denied or suspended in accordance with this section.

13:20-43.17 Inspector training and licensing; training administration; testing; application process; license fee; renewal of license; refresher training and testing; conflicts of interest

(a) No person shall perform an emission inspection required by this subchapter unless licensed by the Division to perform such inspection. In order to obtain licensure as a motor vehicle emission inspector, an applicant shall complete a training program that shall consist of acquiring an understanding of:

1. The air pollution problem, its causes and effects;
2. The purpose, function, and goal of the motor vehicle emission inspection program;
3. Emission inspection regulations and procedures;
4. Technical details of emission test procedures and the rationale for their design;
5. Emission control device function, configuration, and inspection;
6. Emission test equipment operation, calibration, and maintenance;
7. Quality control procedures and their purpose;
8. Public relations; and
9. Personal safety and health issues related to the inspection process.

(b) The Division shall either administer the training program or approve, monitor and evaluate the training programs administered by third parties as set forth in subsection (g) below. The Division shall charge a fee of \$100.00 for the approval of training programs administered by third parties.

(c) An applicant for licensure as a motor vehicle emission inspector shall submit to the Division a license fee of \$50.00 and a certificate confirming that the applicant has successfully completed training and testing at a Division approved emission inspector training program. The applicant shall have attained a score of at least 80 percent of correct responses on a written examination covering all aspects of the training. In addition, a hands-on test shall have been administered in which the applicant demonstrated, without assistance, the ability to conduct a proper inspection, to properly utilize equipment and to follow other procedures adopted by the Division. Inability to properly conduct any emission test procedures shall constitute failure of the test.

(d) A motor vehicle emission inspector license shall be valid for two years. Refresher training and testing shall be required prior to renewal of the license, and each application for license renewal shall be accompanied by the applicable fee specified in (c) above. For purposes of this subsection, "refresher training and testing" shall mean either a training program as set forth in (a) above or an on-the-job evaluation of the licensee's inspection performance and knowledge of current inspection requirements by the Director or his or her designee.

(e) No person licensed as an inspector shall, while in the employment of an official inspection facility, own, operate or be employed by any motor vehicle repair or service facility, motor vehicle parts sales business, or any motor vehicle sales or leasing business. An inspector, other than an inspector employed at an official inspection facility, may be employed by a private inspection facility which is licensed by the Division in accordance with chapter 8 of Title 39 of the Revised Statutes and N.J.A.C. 13:20-44.

(f) No person licensed as an inspector, while in the employment of an official inspection facility, shall refer motor vehicle owners, lessees or operators to particular providers of motor vehicle repair service except as may be permitted by Federal law.

(g) (Reserved).

13:20-43.18 Suspension or revocation of inspector license; retraining and retesting; suspension pending hearing; schedule of penalties

(a) A motor vehicle emission inspector license may be suspended or revoked for any of the following:

1. Fraudulently, willfully or negligently conducting an improper emission inspection of a motor vehicle;
2. Violation of any provision of this subchapter;
3. Violation of any procedure established by the Division or the Department of Environmental Protection for the conduct of emission inspections;
4. Fraudulently, willfully or negligently issuing an improper certificate of approval; or
5. Other good cause.

(b) An inspector who fraudulently or willfully conducts an improper emission inspection of a motor vehicle shall be subject to a suspension of his or her inspector license for a period of at least six months. An inspector whose license is suspended under this section shall successfully complete refresher training and testing in accordance with N.J.A.C. 13:20-43.17(d) before such license is restored under this subchapter.

(c) Any applicant who submits false information when applying for a motor vehicle emission inspector license may be disqualified from receiving the license. In addition, any licensee whose eligibility for a license was based on the submission of false information is subject to license suspension or revocation by the Division.

(d) A motor vehicle emission inspector license may be suspended immediately by the Director upon a charge of a violation that directly affects emission reduction benefits or compromises the integrity of the inspection system. If the Director determines that the public interest requires suspension of a license pursuant to this subchapter prior to hearing, the Director may do so, provided that notice containing the reasons for such suspension and the effective date of the suspension is provided to the licensee in person, or by certified or regular mail, prior thereto and the licensee is afforded the opportunity to request in writing a hearing within 10 days of the effective date of the suspension. When a licensee requests an administrative adjudication it shall be held as soon thereafter as practicable. If the Director determines it necessary to suspend a license prior to hearing and the licensee submits a request for a hearing within the time prescribed by this section, the Director may require that a preliminary hearing be held or may refer the matter to the Office of Administrative Law for a preliminary hearing to determine whether sufficient cause exists to continue such suspension until a plenary hearing can be conducted.

(e) Any hearing concerning the suspension, revocation or refusal to grant or renew a motor vehicle emission inspector license shall be conducted in accordance with the Administrative Procedure Act, N.J.S.A. 52:14B-1 et seq., and the Uniform Administrative Procedure Rules, N.J.A.C. 1:1.

(f) The following penalty schedule shall apply to emission inspector licensees who violate P.L. 1995, c.112 or this subchapter.

1. For intentionally or willfully improperly passing or waiving a vehicle for any required portion of the emission test in violation of rules or procedural requirements:

i. Six month license suspension; plus \$500.00 civil penalty; plus mandatory retraining and retesting	first violation
ii. Two year license suspension; plus \$1,000.00 civil penalty; plus mandatory retraining and retesting	second violation
iii. Lifetime license revocation; plus \$2,000.00 civil penalty	third violation

2. For gross negligence in passing or waiving a vehicle for any required portion of the emission test in violation of rules or procedural requirements:

i. Three month license suspension; plus \$500.00 civil penalty; plus mandatory retraining and retesting	first violation
ii. Six month license suspension; plus \$750.00 civil penalty; plus mandatory retraining and retesting	second violation
iii. Two year license suspension; plus \$1,000.00 civil penalty; plus mandatory retraining and retesting	third violation
iv. Lifetime license revocation; plus \$2,000.00 civil penalty	fourth violation

3. For simple negligence in passing or waiving a vehicle for any required portion of the emission test in violation of rules or procedural requirements:

- i. Two week license suspension; plus \$500.00 civil penalty; plus mandatory re-training and retesting first violation
- ii. One month license suspension; plus \$500.00 civil penalty; plus mandatory re-training and retesting second violation
- iii. Three month license suspension; plus \$750.00 civil penalty; plus mandatory re-training and retesting third violation
- iv. Six month license suspension; plus \$750.00 civil penalty; plus mandatory re-training and retesting fourth violation
- v. Two year license suspension; plus \$1,000.00 civil penalty; plus mandatory retraining and retesting fifth and subsequent violations

4. For misrepresentation on application (fraud or misrepresentation in securing the license):

- i. Three-year license denial or suspension

5. For fraudulently affixing certificate of approval, certificate of waiver or rejection sticker:

- i. Immediate two-year license suspension; plus \$500.00 civil penalty first violation
- ii. Immediate four-year license suspension; plus \$1,000.00 civil penalty second violation
- iii. Lifetime license revocation; plus \$2,000.00 civil penalty third violation

6. For fraud or misrepresentation in the conduct of the licensed activity:

- i. Immediate two-year license suspension first violation
- ii. Immediate four-year license suspension second violation
- iii. Lifetime license revocation third violation

7. For issuance or possession of altered, forged, stolen, or counterfeit certificate of approval, certificate of waiver or rejection sticker:

- i. Two-year license suspension first violation
- ii. Four-year license suspension second violation
- iii. Lifetime license revocation third violation

8. For furnishing, lending, giving or selling a certificate of approval, certificate of waiver or rejection sticker without performing the required inspection or reinspection:

- i. Two-year license suspension first violation
- ii. Four-year license suspension second and subsequent violations

9. For fraudulent recordkeeping:

- i. Immediate two-year license suspension first violation
- ii. Immediate four-year license suspension second violation
- iii. Lifetime license revocation third violation

10. For failing to produce inspection records:

- i. Immediate license suspension until compliance

11. For improper recordkeeping:

- i. One-month license suspension first violation
- ii. Two-month license suspension second violation
- iii. Six-month license suspension third and subsequent violations

12. For improper security of certificates of approval, certificates of waiver and/or rejection stickers:

- i. Written warning first violation
- ii. Two-month license suspension second violation
- iii. Six-month license suspension third and subsequent violations

13. For lost or stolen certificates of approval, certificates of waiver, and/or rejection stickers for which the licensee does not properly account. A licensee can "properly account" for such documents by demonstrating, to the satisfaction of the Director, that they were lost or stolen under circumstances beyond the reasonable control of the licensee:

- i. One-month license suspension first violation
- ii. Two-month license suspension second violation
- iii. One-year license suspension third and subsequent violations

14. For overcharging on inspection/reinspection:

- i. Written warning first violation
- ii. 30-day license suspension second violation
- iii. 60-day license suspension third and subsequent violations

15. For failure to provide vehicle inspection report and/or work order to the customer:

- i. 30-day license suspension first violation
- ii. 60-day license suspension second violation
- iii. One-year license suspension third and subsequent violations

16. For criminal conviction which is disqualifying:

- i. Indefinite denial/suspension

Issuance/restoration predicated on standards set forth in the Rehabilitated Convicted Offenders Act (N.J.S.A. 2A:168A-1 et seq.).

13:20-43.19 Quality assurance; auditor training

(a) Any person licensed or authorized by the Division to perform inspections required by this subchapter shall cooperate fully with the Division, the Department of Environmental Protection, or their authorized representatives, in the conduct of any audits or reviews authorized by the Division or the Department. All books, records, documents, papers, reports, or data relating to the performance of inspections required by this subchapter, in whatever form kept, shall be open to inspection by the Division or the Department of Environmental Protection at such times and at such locations as the Division or the Department may specify. The Division, the Department of Environmental Protection, or their authorized representatives, may conduct covert and overt audits of the performance of inspectors or inspection facilities and the equipment utilized by such persons at any times during which inspections are being performed or the facility is open for business. In conducting an audit or review, the Division, the Department of Environmental Protection, or their authorized representatives shall be given unfettered access to all areas of an inspection facility and to all equipment at such facility. The Division or the Department of Environmental Protection may conduct audits or reviews at such frequencies as they deem appropriate to assure the integrity and performance of the inspection system.

(b) Auditors shall be formally trained and knowledgeable in:

1. The use of analyzers;
2. Program rules and regulations;
3. The basics of air pollution control;
4. Basic principles of motor vehicle engine repair relating to emission performance;
5. Emission control systems;
6. Evidence gathering;
7. State administrative procedures laws;
8. Quality assurance practices; and
9. Covert audit procedures.

SUBCHAPTER 44. PRIVATE INSPECTION FACILITY LICENSING

Authority

P.L. 1995, c.112, N.J.S.A. 39:2-3, 39:3-43, 39:8-4.1, 42 U.S.C. § 7401 et seq. and 40 C.F.R. § 51.350 et seq.

Source and Effective Date

R.1995 d.528, effective August 28, 1995.
See: 27 N.J.R. 2777(a), 27 N.J.R. 3820(a).

Subchapter Historical Note

Subchapter 44, Private Inspection Facility Licensing, was adopted as Emergency New Rules by R.1995 d.410, effective June 29, 1995, to expire August 28, 1995. See: 27 N.J.R. 2777(a). The concurrent proposal of Subchapter 44 was adopted as R.1995 d.528, effective August 28, 1995. See: Source and Effective Date. See, also, section annotations.

13:20-44.1 Purpose

(a) P.L. 1995, c.112 provides for the licensing and regulation of private inspection facilities by the Director of the Division of Motor Vehicles. The purposes of this subchapter are to:

1. Establish a system for the licensing of private inspection facilities which perform inspections and/or reinspections on motor vehicles and issue certifications for motor vehicles, including emission control system inspections; and
2. Establish standards and procedures necessary to protect the public from incompetent, dishonest, deceptive and fraudulent practices in the inspection, reinspection and certification of motor vehicles, including emission control systems, and to eliminate or exclude from licens-

ing those persons who engage in such practices or who otherwise demonstrate unfitness.

(b) The Division finds that in order to ensure that motor vehicles which are inspected, reinspected and certified by a private inspection facility are satisfactorily inspected, reinspected and certified and are in proper condition to be operated on the highways of this State and to ensure that inspections, reinspections and certifications are performed in accordance with the standards established by the Division at N.J.A.C. 13:20-43 and the Department of Environmental Protection at N.J.A.C. 7:27 and 7:27B, a licensed private inspection facility must possess certain equipment used in the inspection, reinspection and certification of motor vehicles, including emission control systems.

13:20-44.2 Definitions

The following words and terms, when used in this subchapter, shall have the following meanings, unless the context clearly indicates otherwise:

“Advertising” means any printed or published materials including, but not limited to, direct mail, circulars, leaflets, pamphlets, newspapers, magazines, billboards, yellow pages of any telephone directory, radio and/or television broadcasts, and any other advertising medium of communication used to induce the public to seek the services of the private inspection facility. The term “advertising” shall not include printed or published materials appearing in the white pages of any telephone directory.

“Applicant” means any person applying under the provisions of this subchapter for an initial license to engage in the business of a private inspection facility or to renew an existing license. In the case of a partnership or corporation applying for a license, the term “applicant” shall respectively include all partners and/or officers and directors and/or persons having a controlling interest in a sole proprietorship or corporation.

“Controlling interest” means possession of the power to direct or cause the direction of the management and policies of a private inspection facility, whether through the ownership of voting securities or otherwise. The Director will presume that control in fact exists if any person or entity directly or indirectly owns, controls, holds the power to vote, or holds proxies representing 10 percent or more of the voting securities of any private inspection facility. This presumption may be rebutted by showing that control does not in fact exist. The Director may determine that control in fact exists, notwithstanding the presence or absence of a presumption to that effect.

“Department” means the Department of Environmental Protection in the State of New Jersey.

“Director” means the Director of the Division of Motor Vehicles in the Department of Transportation in the State of New Jersey.

“Division” means the Division of Motor Vehicles in the Department of Transportation in the State of New Jersey.

“Emission control system” means a device or equipment installed on a motor vehicle by the manufacturer for the purpose of controlling air contaminants emitted from the motor vehicle or motor vehicle engine, including devices or equipment integral with but not limited to exhaust emission control systems, fuel evaporation control systems, crankcase emission control systems, and associated devices or systems which control or monitor the function of these devices or systems.

“Engaged in the business” means:

1. Any person who inspects, reinspects and certifies motor vehicles, including motor vehicle emission control systems; or
2. Any person who for compensation negotiates, in any manner, with any customer to inspect, reinspect and certify motor vehicles, including emission control systems.

“Federal Clean Air Act” means the federal “Clean Air Act,” 42 U.S.C. §7401 et seq., and any subsequent amendments or supplements to that act.

“Gross vehicle weight rating (GVWR)” means the value specified by the manufacturer as the maximum loaded weight of a single or combination (articulated) vehicle.

“Heavy-duty gasoline-fueled vehicle” means a gasoline-fueled motor vehicle that has a GVWR of more than 8,500 pounds and that is designed primarily for transportation of persons or property.

“Light-duty gasoline-fueled truck” means a gasoline-fueled motor vehicle that has a GVWR of 8,500 pounds or less, a vehicle curb weight of 6,000 pounds or less, and a basic frontal area of 45 square feet or less, and that is:

1. Designed primarily for the transportation of property or more than 12 passengers; or
2. Available with special features enabling off-street or off-highway operation and use.

“Light-duty gasoline-fueled vehicle” means a gasoline-fueled motor vehicle that has a GVWR of 8,500 pounds or less, is designed primarily for use as a passenger car or is a passenger car derivative and is capable of seating 12 or fewer passengers.

“Model year” means, with respect to a motor vehicle, the year in which the motor vehicle is considered to have been manufactured. If the manufacturer establishes an annual production period, designation of the year shall be based on the annual production period during which the manufacturer begins production of the motor vehicle. When such annual production period falls within one calendar year, the model year attributed to the motor vehicle shall be that calendar year. When such annual production period continues from one calendar year into the next, the model year attributed to the motor vehicle shall be the latter calendar year (for example, a motor vehicle produced in an annual production period that continues from 1994 to 1995 shall be considered as being produced in the 1995 model year). If the manufacturer establishes no annual production period, a motor vehicle’s model year shall be the calendar year in which the manufacturer begins production of that motor vehicle. If a motor vehicle is manufactured in two or more stages, the model year of such a motor vehicle shall be based on the date of completion of the chassis. In case of any dispute, the Director shall have sole discretion to determine the model year of a vehicle for purposes of this subchapter. For purposes of this subchapter, the Director may, in his or her discretion, determine that “model year” means the model year designated for the motor vehicle as contained in the vehicle identification number for such vehicle.

“Motor vehicle emission testing equipment” means equipment in accordance with specifications contained in N.J.A.C. 7:27B, Appendix 7 (“Specifications for Motor Vehicle Emission Testing Equipment for Use in the New Jersey Enhanced Inspection and Maintenance Program”). The equipment shall include all devices used for performing a motor vehicle emission inspection, including, but not limited to, exhaust gas analyzers, evaporative pressure testing apparatus, evaporative purge testing apparatus, dynamometers, computers and related software.

“Person” means any natural person, business, company, firm, partnership, association, corporation or any other entity.

“Place of business” means the address or location where the services of a private inspection facility are offered or ordinarily performed.

“Private inspection facility” means any person who for compensation engages in the business of inspecting, reinspecting and certifying motor vehicles, including emission control systems. For purposes of this subchapter, an employee of a private inspection facility who engages in the business of inspecting, reinspecting and certifying motor vehicles, including emission control systems, solely by reason of his or her employment is not deemed to be a private inspection facility and is not required to be licensed as such.

“Private inspection facility license” means a license issued to a private inspection facility which evidences the Director’s authorization for the facility to engage in the inspection, reinspection and certification of motor vehicles, including motor vehicle emission control systems.

“Reconstructed vehicle” means a vehicle which has been materially altered from its original construction by the removal, addition or substitution of essential parts, new or used.

“Suspension, revocation or refusal to grant or renew” means administrative action by the Director, in accordance with the provisions of P.L. 1995, c.112 or this subchapter, to refuse to grant or renew a private inspection facility license or to suspend or revoke an existing license.

13:20-44.3 Scope; license required; vehicle classes; inspection services; fleet facilities

(a) This subchapter shall apply to every person engaged in the business of a private inspection facility which performs inspections, reinspections and certifications of motor vehicles, including emission control systems.

(b) No person shall, on or after June 29, 1995, engage in the business of a private inspection facility unless licensed by the Director in accordance with the provisions of this subchapter.

(c) Private inspection facilities shall be licensed to engage in the inspection, reinspection and certification of light-duty gasoline-fueled vehicles, light-duty gasoline-fueled trucks, heavy-duty gasoline-fueled vehicles and buses; provided, however, private inspection facilities shall not inspect school buses, buses which are subject to inspection by the New Jersey Department of Transportation, motor vehicles with modified chassis height which are subject to inspection in accordance with N.J.A.C. 13:20-37, motor vehicles which are operated by handicapped persons and which have been modified so that such vehicles are fully controlled by specially designed mechanical devices for the handicapped, or reconstructed vehicles.

(d) Private inspection facilities shall provide inspection, reinspection and certification services in all vehicle inspection categories established by the Division, including the following inspection categories:

1. Engine emissions;
2. Brake system;
3. Exhaust system;
4. Steering, suspension, tires and wheels;
5. Glass (windshield, windows);
6. Electrical (all switches, signals, wipers, lenses and lights, including headlights); and

7. Miscellaneous (any inspection item not in other categories)

(e) Each motor vehicle inspection conducted by a private inspection facility pursuant to this subchapter shall include an examination of the driver’s license, motor vehicle registration certificate and insurance identification card.

(f) Private inspection facilities shall be authorized to perform inspections, reinspections and certifications in all vehicle inspection categories established by the Division.

(g) Private inspection facilities shall be authorized to perform inspections, reinspections and certifications on vehicles owned or leased by the licensee.

(h) Any private inspection facility which is also registered as a motor vehicle emission repair facility pursuant to N.J.A.C. 13:20-45 and which inspects, reinspects and certifies fleet motor vehicles that it owns or leases shall be exempted from the requirements of N.J.A.C. 13:20-45.10 for those vehicles.

13:20-44.4 Initial application for a license

(a) Any person seeking to engage in the business of a private inspection facility shall apply, in accordance with the provisions of this subchapter, to the Director for a license authorizing him or her to engage in such business. An application for a private inspection facility license may be obtained from the Private Inspection Facility Licensing Unit of the Division. The address of the Private Inspection Facility Licensing Unit is:

Division of Motor Vehicles
Business License Compliance
Private Inspection Facility Licensing Unit
225 East State Street
CN 170
Trenton, New Jersey 08666-0170

(b) Each applicant for a private inspection facility license shall file with the Director, in such form and detail as may be required by him or her, an application setting forth the following:

1. The name, place of business and telephone number of the private inspection facility;
2. The name, business and residence address(es), driver’s license number, social security number and telephone number(s) of:
 - i. The owner and/or possessor of a controlling interest of the facility, in the case of a sole proprietorship;
 - ii. Each partner, in the case of a partnership; or
 - iii. Each officer, director and possessor of a controlling interest, in the case of a corporation;

3. The businesses in which the applicant has been engaged for the five years preceding the date of application, and if employed, the names and addresses of the employers;

4. Whether the applicant has ever been convicted of a crime, disorderly persons offense or petty disorderly persons offense;

5. Whether the applicant has ever been found to be in violation of the Federal Clean Air Act or the Consumer Fraud Act (N.J.S.A. 56:8-1 et seq.) or any regulations adopted thereunder or N.J.A.C. 7:27-15.7 pertaining to tampering with emission control apparatus;

6. Whether the applicant has ever been denied, or had suspended or revoked, a license or registration to engage in any business, profession or occupation licensed or registered under the laws of any state; and

7. Whether the applicant has any interest in any other private inspection facility or any motor vehicle related business.

(c) Each initial application for a private inspection facility license shall be accompanied by proof of the following:

1. The New Jersey Sales Tax Identification Number;
2. The New Jersey Unemployment Registration Number;
3. The Federal Employer Identification Number;
4. The corporation code, if one has been issued by the Division;
5. Proof in such form as the Director may require that the applicant meets the requirements of N.J.A.C. 13:20-44.9; and
6. Proof of valid permits or other authorization from the appropriate Federal, State or other governmental agencies authorizing operation of the business or any equipment, service or process on the premises. These permits shall include, but are not limited to, proof of registration with the New Jersey Division of Taxation and the Department of Environmental Protection.

(d) Each initial application for a private inspection facility license shall be accompanied by a color photograph and a complete set of fingerprints for each natural person required to be listed on the application by this section.

1. The applicable nonrefundable fee as set forth at N.J.A.C. 13:59-1.2 payable to the Division of State Police—State Bureau of Identification shall be submitted for each natural person required to be fingerprinted. The payment of this fee shall be in the form of a cashier's check, certified check or money order as required by N.J.A.C. 13:59-1.5.

2. Fingerprints required by this subsection shall be taken by a member of the State Police or municipal law enforcement agency and submitted on the standard fingerprint cards as required by N.J.A.C. 13:59-1.4.

(e) Each initial application for a private inspection facility license shall be accompanied by proof of liability insurance coverage in the following minimum amounts: for injury to, or death of any one person in any one occurrence: \$100,000; for injury to, or death of two or more persons in any one occurrence: \$300,000; for damage to property in any one occurrence: \$50,000. Proof of insurance coverage shall be in the form of a certificate issued by the carrier containing a clause that 30 days prior notice shall be given to the Division of any cancellation or termination of the policy. Failure to maintain such insurance coverage shall be cause for immediate license suspension.

(f) Each initial application for a private inspection facility license shall be accompanied by the applicable fees as specified in N.J.A.C. 13:20-44.6.

(g) If there are multiple locations for private inspection facilities owned by the same applicant, a separate application, accompanying documents, and application and license fee as specified in N.J.A.C. 13:20-44.6 shall be submitted for each such place of business.

(h) Upon preliminary approval of each initial license application, a license shall be issued to the private inspection facility. Each initial license issued to a private inspection facility on or after June 29, 1995 shall be effective on the date of issuance and shall continue in force and effect until June 30, 1998, and shall, thereafter, be renewed on an annual basis, unless such license is suspended or revoked by the Director. If there are multiple places of business for a private inspection facility, a separate license shall be issued for each such place of business.

(i) The Director may grant a conditional license to an applicant who submits proof that all of the requirements for licensing will be met in accordance with a schedule set by the Director, and who agrees that the conditional license will be surrendered immediately if proof is not provided in accordance with the schedule. The Director may suspend the license of an applicant who does not surrender the conditional license when so required.

(j) All private inspection facilities that apply to renew a private inspection facility license on or after June 29, 1995 must satisfy all of the requirements of (c)5 above. A private inspection facility whose license has been suspended by the Director and which applies for reinstatement on or after June 29, 1995 must satisfy the requirements of (c)5 above prior to restoration of the license.

(k) The Division shall not issue a private inspection facility license to an applicant who is the holder of a private inspection center license while any type of enforcement action, either judicial or administrative, is pending or in force against the applicant's private inspection center license.

13:20-44.5 Applicant qualifications

(a) Each applicant shall be a proper person to hold a private inspection facility license. In assessing whether an applicant is a proper person, the Director shall consider the character, financial responsibility, prior record while operating as a principal of a business entity licensed or regulated by the Division, and criminal record of the individual applicant, the individual partners, the officers, directors and/or persons possessing a controlling interest, and anyone employed by, or otherwise associated in business with, the applicant. The Director shall also consider whether the private inspection facility has maintained acceptable levels of customer satisfaction, the nature and number of all valid customer complaints against the private inspection facility, and the manner and extent by which those complaints have been resolved by the private inspection facility.

(b) Each applicant shall be at least 18 years old, and must have the legal capacity to contract, to be sued and to be liable for all debts.

13:20-44.6 Application and license fees

(a) Each initial application for a private inspection facility license shall be accompanied by a nonrefundable application fee of \$20.00 payable to the Division.

(b) Each initial or renewal application for a private inspection facility license shall be accompanied by a license fee of \$250.00 payable to the Division. Such license fee shall be returned to the applicant only in the event that the Director refuses to grant or renew a private inspection facility license. Such license fee, or any portion thereof, shall not be refunded to the licensee in the event that the private inspection facility license is suspended or revoked pursuant to N.J.S.A. 39:8-1 et seq. or this subchapter, or if the licensee voluntarily surrenders the license at any time during the license period.

13:20-44.7 License renewals

(a) Each licensee shall, no later than 30 days before the expiration of the license, submit to the Director an application to renew its current license provided that such licensee is not prohibited from applying for a license as specified in N.J.A.C. 13:20-44.25. An application to renew a private inspection facility license may be obtained from the Private Inspection Facility Licensing Unit of the Division at the address specified in N.J.A.C. 13:20-44.4(a).

(b) Each application to renew a private inspection facility license shall be accompanied by the applicable fee specified

in N.J.A.C. 13:20-44.6(b) and proof of liability insurance coverage as specified in N.J.A.C. 13:20-44.4(e).

(c) Upon approval of each renewal application, a license shall be issued to the private inspection facility. Each renewal license issued to a private inspection facility effective on or after July 1 of any year shall continue in force and effect until June 30 of the following year, unless such license is suspended or revoked by the Director.

13:20-44.8 Surrender of license

(a) Each private inspection facility license, although issued and delivered to a licensee, shall at all times be the property of the State of New Jersey.

(b) Upon any suspension, revocation, refusal or failure to renew or other termination of a private inspection facility license, the license shall no longer be in force and effect and the license shall be surrendered forthwith upon demand of a Division representative.

13:20-44.9 Facilities and equipment

(a) Licensed private inspection facilities shall be located in a structure having a garage-type entrance and one or more service bays or lanes; except that licensed private inspection facilities which perform inspections, reinspections and certifications exclusively at the business locations of owners or lessees of fleet motor vehicles may be exempted from the provisions of this subsection.

(b) Motor vehicle emission testing equipment, approved by the Department of Environmental Protection, shall be owned or leased by a private inspection facility and shall be located on the business premises of the facility.

(c) A vehicle lift or heavy duty floor jack shall be available on the business premises of the facility.

(d) Brake testing equipment, for example, a drive-on horizontal scale or roller-type tester, shall be available on the business premises of the facility. The brake testing equipment requirements of this subsection may be waived by the Division upon receipt of written notification from the licensee expressing its commitment to make visual inspections of the brake system and to perform road tests of the brake system.

(e) A tire tread depth gauge calibrated in 32nds of an inch shall be available on the business premises of the facility.

(f) Electronic medium for retrieval of inspection information from and for transmission of inspection information to the Division's data base shall be available on the business premises of the facility.

13:20-44.10 Inspection certificates of approval

(a) The inspection certificate of approval shall be composed of a base inspection sticker indicating the calendar year of its validity and shall contain a bar-coded identifier linked to the vehicle.

(b) Base inspection stickers shall be purchased by a licensee, by mail or in person, from the Division of Motor Vehicles, 225 East State Street, Trenton, New Jersey 08666.

(c) Base inspection stickers shall be purchased by a licensee at \$1.00 per sticker in quantities of 50 or more.

(d) A licensee shall secure base inspection stickers in a locked place of limited access, such as a safe, cabinet or desk drawer. The licensee is solely responsible for the security of base inspection stickers. A licensee's failure to take necessary precautions to secure base inspection stickers from loss or theft shall be cause for suspension or revocation of the license.

(e) A licensee shall affix base inspection stickers to a vehicle only after inspection or reinspection has been completed.

(f) When defects detected at an inspection conducted at an official inspection facility or at a private inspection facility have been repaired or adjusted by the licensee or by an employee of the licensee, the licensee shall insure, prior to affixation of a certificate of approval on the vehicle, that the person or persons who performed the repair or adjustment work has signed his or her name on the motor vehicle inspection report. When defects detected at inspection have been repaired by someone other than the licensee or an employee of the licensee, the licensee shall insure, prior to affixation of a certificate of approval on the vehicle, that the person or persons who inspected the vehicle have signed his or her name on the motor vehicle inspection report at the bottom of its reverse side.

(g) A licensee shall not certify the emissions of any vehicle unless an emission inspector licensed by the Division in accordance with chapter 8 of Title 39 of the Revised Statutes and N.J.A.C. 13:20-43.17 has personally performed the emission inspection and has determined that the vehicle meets the emission standards adopted by the Division at N.J.A.C. 13:20-43 and the Department of Environmental Protection at N.J.A.C. 7:27 and 7:27B. After July 1, 1998, a licensee shall not certify the emissions of any vehicle unless a certified emission repair technician has performed the emission-related repairs, other than repairs of the primary emission control components.

(h) A licensee shall secure motor vehicle inspection reports separate and apart from base inspection stickers in a locked place of limited access, such as a safe, cabinet or desk drawer.

(i) A licensee shall record the date of issuance of the base inspection sticker on the corresponding motor vehicle inspection report.

(j) A licensee shall retain defective or voided base inspection stickers and motor vehicle inspection reports and shall surrender them to a Division representative at the time of a periodic audit conducted by the Division.

(k) A licensee shall notify the local law enforcement agency upon determining that a base inspection sticker(s) has been stolen and shall file a copy of such report with the Division.

(l) A licensee shall return all unused base inspection stickers and inspection reports to a Division representative upon the licensee's discontinuation of inspection certification services.

(m) A licensee shall be solely responsible for base inspection stickers and inspection reports issued to it by the Division.

13:20-44.11 Responsibility of licensees

(a) In the case of a sole proprietorship, the owner and/or possessor of a controlling interest in the private inspection facility shall be responsible to the Director for the conduct of the business of the facility and for all actions performed by its employees in connection with the business of the facility concerning violations of P.L. 1995, c.112 or this subchapter.

(b) In the case of a partnership or corporation, each partner, or corporate officer and/or director, or any person or entity possessing a controlling interest, as the case may be, shall be held individually responsible to the Director for the conduct of the business of the facility and for all actions performed by its employees in connection with the business of the facility concerning violations of P.L. 1995, c.112 or this subchapter.

13:20-44.12 Notice and recordkeeping requirements

(a) Each licensee, except a private fleet inspection facility, shall display an outdoor sign which shall read: "Licensed: State of New Jersey Private Inspection Facility". The sign shall include the license number of the private inspection facility. The sign must contain letters at least two inches high with a stroke of approximately one-half inch, be visible from the road and be located in a conspicuous location for the general public to see. If zoning ordinances prohibit the posting of such sign or such posting is otherwise impractical, the licensee shall prominently display such sign on the exterior of the private inspection facility.

(b) Every license issued in accordance with this subchapter shall be prominently displayed in the office, waiting area or other conspicuous location which is accessible to the public at the private inspection facility.

(c) Every licensed private inspection facility shall maintain copies of all motor vehicle inspection reports and other documents prepared by that facility for inspections, re-inspections, certifications and repair work performed by that facility.

1. Such copies shall be kept for at least four years and shall be available for inspection by the Director, the Attorney General, the Commissioner of the Department of Environmental Protection, the Director of the Division of Consumer Affairs, the Superintendent of the Division of State Police, or any person designated by them, during normal business hours.

2. A licensee's failure to permit such inspection shall subject the licensee to administrative action pursuant to this subchapter.

(d) Every private inspection facility shall, upon request of the Director or any person designated by him or her, provide the Director or his or her designee with a list of its employees in such form and detail as may be required by the Director or his or her designee. Failure to provide such list when requested shall subject the licensee to administrative action pursuant to this subchapter.

(e) The licensee shall notify the Director in writing within 10 days whenever any person acquires ownership or control of 10 percent or more of the stock of a private inspection facility, or whenever a person becomes a partner or limited partner in a private inspection facility.

(f) The licensee shall notify the Director in writing within 10 days of any change in address of the private inspection facility or of any change in address of persons or entities required to be listed on the application by N.J.A.C. 13:20-44.4.

(g) The licensee shall notify the Director in writing within 10 days whenever any person or entity required to be listed on the application by N.J.A.C. 13:20-44.4 is no longer associated with the private inspection facility.

(h) All written notifications required by this subchapter shall be made by either personal delivery or sent by certified mail to the Private Inspection Facility Licensing Unit of the Division at the address specified in N.J.A.C. 13:20-44.4(a).

(i) An amended application shall be filed by the licensee with the Director when there is a substitution and/or addition of persons or entities required to be listed on the application by N.J.A.C. 13:20-44.4. The licensee shall also comply with the requirements of N.J.A.C. 13:20-44.6(a) and 13:20-44.4(d).

(j) Any process issued to a licensee pursuant to the statutory authority of the Director including, but not limited to, subpoenas, orders, and orders to show cause, may be served upon a licensee or counsel of record, by sending said process by certified or ordinary mail, to the business address

of the private inspection facility or to counsel's address on record with the Division.

13:20-44.13 Records; inspection reports

(a) A licensee shall maintain copies of motor vehicle inspection reports in order corresponding to the date on which the base inspection sticker was issued.

(b) A licensee shall maintain repair orders and invoices (bills for parts and labor) in the form required by the deceptive automotive repair work and advertising practices rules (N.J.A.C. 13:45A-7).

(c) A licensee shall record the repair order and invoice number or numbers on the motor vehicle inspection report.

(d) Records required to be maintained by a licensee pursuant to this section shall remain on file at the licensee's place of business for a period of four years from the date of issuance of the base inspection sticker.

(e) Records required to be maintained by a licensee pursuant to this section shall be made available by the licensee for examination by authorized representatives of the Division, the Department of Environmental Protection and the Division of Consumer Affairs at any time during regular business hours. Investigators and other authorized representatives of the Division, the Department of Environmental Protection and the Division of Consumer Affairs shall be granted access to the licensee's business premises during regular business hours.

(f) A licensee's failure to permit investigators and other personnel of the Division, the Department of Environmental Protection and the Division of Consumer Affairs on the premises of the licensee during regular business hours for purposes of conducting investigations shall be cause for suspension or revocation of the private inspection facility license. Such investigations may include, but shall not be limited to, discussions with customers, examination of motor vehicle emission testing equipment and other equipment specified in N.J.A.C. 13:20-44.9, questioning of employees and the employment of such other investigatory techniques as may be necessary for the enforcement of this subchapter and the provisions of Title 39, Title 26 and Title 56 of the Revised Statutes and the regulations adopted thereunder by the Division at N.J.A.C. 13:20-43, the Department of Environmental Protection at N.J.A.C. 7:27 and 7:27B and the Division of Consumer Affairs at N.J.A.C. 13:45A-7.

13:20-44.14 Certification of inspection

(a) Each licensed private inspection facility shall have the authority to perform inspections in all vehicle inspection categories established by the Division and to certify that specific items for which a vehicle was rejected at inspection have been corrected so that the vehicle is in working order and that it conforms to the emission standards adopted by the Division at N.J.A.C. 13:20-43 and the Department of

Environmental Protection at N.J.A.C. 7:27 and 7:27B. A licensed private inspection facility shall not perform an initial emission inspection on vehicles which are more than four years old. A licensed private inspection facility shall not perform an emission reinspection on vehicles that have failed an initial emission inspection in two consecutive test cycles.

(b) No licensee shall certify that items for which a vehicle was rejected at inspection have been corrected unless the licensee or a licensed emission inspector acting as an employee or agent of the licensee has inspected the vehicle and has determined that all defects detected at inspection have been corrected so that the vehicle is in working order and that it conforms to the emission standards adopted by the Division at N.J.A.C. 13:20-43 and the Department of Environmental Protection at N.J.A.C. 7:27 and 7:27B.

(c) Certification shall be evidenced by the affixation of a certificate of approval on the vehicle as specified in N.J.A.C. 13:20-43.11(a).

(d) Certification of a vehicle by a licensee or an employee shall constitute the licensee's representation that the licensee or a licensed emission inspector has inspected the vehicle and has determined that the vehicle is in working order and conforms to the emission standards adopted by the Division at N.J.A.C. 13:20-43 and the Department of Environmental Protection at N.J.A.C. 7:27 and 7:27B.

(e) The fee which a licensee may charge the consumer for affixing a certificate of approval shall not exceed \$1.50.

(f) The fee which a licensee may charge for inspection of items rejected after inspection and which have been repaired by the vehicle owner or lessee or someone not under the direction of the licensee shall not exceed that portion of the licensee's established hourly labor charge for repair service as specified by the Director to be the average time required to inspect a particular item of equipment. A licensee shall inform the consumer in advance that the licensee's charge for such inspection shall not exceed that portion of the hourly labor rate.

(g) Every licensee who performs inspection certification services for the general public shall conspicuously display a schedule of inspection charges at his or her place of business and shall file a copy thereof with the Private Inspection Facility Licensing Unit. The posted schedule shall not be smaller than one square foot.

13:20-44.15 Advertising

(a) Any advertising used by the private inspection facility in any printed or published material shall contain and prominently display the license number of the facility.

(b) Any advertising used by the private inspection facility in any radio broadcast shall disclose that the facility is licensed by the State of New Jersey.

(c) Any advertising used by the private inspection facility in any television broadcast shall prominently display the license number of the facility at the end of such broadcast.

13:20-44.16 Storage rates

Every private inspection facility which charges a per diem fee to store a motor vehicle on its premises shall disclose in writing, prior to initiating inspection certification services, the amount of such storage charge to the customer.

13:20-44.17 Additional violations

(a) In addition to any violation of N.J.S.A. 39:8-1 et seq., the Director may refuse to issue a license or a renewal thereof, or suspend or revoke the existing license of any private inspection facility if he or she determines that the applicant or licensee:

1. Has made a false statement or concealed a fact in connection with the application for a license or a renewal thereof;
2. Is not the owner of, or possessor of a controlling interest in, the private inspection facility;
3. Has been found to have tampered with emission control apparatus in violation of N.J.A.C. 7:27-15.7;
4. Has been found to have violated or conducted fraudulent or deceptive practices concerning the inspection, reinspection, certification and/or repair of motor vehicles in violation of N.J.S.A. 39:8-1 et seq., 56:8-1 et seq., N.J.A.C. 13:45A-7 or this subchapter;
5. Has a criminal record which is disqualifying. A disqualifying criminal record shall include a conviction of any offense in any jurisdiction which would be:
 - i. Any of the following offenses under the "New Jersey Code of Criminal Justice," P.L. 1978, c.95 (Title 2C of the New Jersey Statutes) as amended and supplemented:

All crimes of the first degree;

N.J.S.A. 2C:5-1 (attempt to commit an offense which is listed in this subparagraph);

N.J.S.A. 2C:5-2 (conspiracy to commit an offense which is listed in this subparagraph);

N.J.S.A. 2C:11-4b (manslaughter);

N.J.S.A. 2C:11-5 (death by auto);

N.J.S.A. 2C:12-1b (aggravated assault);

N.J.S.A. 2C:13-1 (kidnapping);

N.J.S.A. 2C:14-1 et seq. (sexual offenses);

N.J.S.A. 2C:15-1 (robberies);

N.J.S.A. 2C:17-1a and b (crimes involving arson and related offenses);

N.J.S.A. 2C:17-2a and b (causing or risking wide-spread injury or damage);

N.J.S.A. 2C:18-2 (burglary);

N.J.S.A. 2C:20-1 et seq. (theft and related offenses);

N.J.S.A. 2C:21-4a (falsifying or tampering with records);

N.J.S.A. 2C:27-1 et seq. (bribery and corrupt influence);

N.J.S.A. 2C:28-1 et seq. (perjury and other falsification in official matters);

N.J.S.A. 2C:30-2 and N.J.S.A. 2C:30-3 (misconduct in office and abuse of office);

N.J.S.A. 2C:35-5 (manufacturing, distributing or dispensing a controlled dangerous substance or a controlled dangerous substance analog);

N.J.S.A. 2C:35-6 (employing a juvenile in a drug distribution scheme);

N.J.S.A. 2C:35-7 (distributing, dispensing, or possessing a controlled dangerous substance or controlled substance analog on or within 1,000 feet of school property or bus);

N.J.S.A. 2C:35-10 (possession, use or being under the influence of a controlled dangerous substance or a controlled substance analog, or failure to make lawful disposition of same);

N.J.S.A. 2C:35-11 (distribution, possession or manufacture of imitation controlled dangerous substances);

N.J.S.A. 2C:35-13 (acquisition of controlled dangerous substances by fraud); or

ii. Any other offense under New Jersey or Federal law which indicates that licensure of the applicant or continued licensure of the licensee would be inimical to the licensing standards set forth in P.L. 1995, c.112 and this subchapter;

6. Demonstrates a pattern of conduct whereby inspections, reinspections, certifications and/or repairs made by the private inspection facility were not made in the prescribed manner;

7. Issues a check in payment of any fees required by this subchapter which is subsequently dishonored;

8. Has failed to comply with any of the provisions of this subchapter;

9. Fails to maintain an approved place of business in accordance with this subchapter;

10. Fails to pay any fee required by law or regulation;

11. Does not have valid permits, as provided for in N.J.A.C. 13:20-44.4(c)(5), or other authorization from the appropriate Federal, State or other governmental agency authorizing operation of the business or operation of any equipment, service or process on the premises;

12. Fails to notify the Director in writing as required by N.J.A.C. 13:20-44.12(e), (f) and (g);

13. Has in its possession any motor vehicle, major motor vehicle component part or component part as defined in N.J.S.A. 39:10B-1 or replacement parts on which the vehicle identification number or other identification affixed thereto in accordance with Federal theft prevention standards has been removed, altered, defaced, destroyed, or so covered as to be concealed; or

14. For other good cause.

13:20-44.18 Emission inspector

The licensee or someone in his or her employment shall be licensed as an emission inspector in accordance with chapter 8 of Title 39 of the Revised Statutes and N.J.A.C. 13:20-43.17.

13:20-44.19 Mechanic qualifications

(a) If the private inspection facility performs safety equipment repairs, the licensee or someone in his or her employment shall meet one of the following criteria:

1. One year experience as a paid automotive mechanic and successful completion of advanced courses in automotive mechanics specifically designed for professionals engaged in the trade; or

2. Three or more years paid experience in general automotive repair and service or at least one year paid experience and completion of an automotive repair course at a vocational school, provided the applicant has successfully passed the National Institute for Automotive Service Excellence Test for engine tuneup and at least one other test from the following areas:

- i. Brakes;
- ii. Front end; or
- iii. Automotive electrical systems.

13:20-44.20 Additional penalties; schedule of penalties

(a) Where, pursuant to N.J.S.A. 39:8-1 et seq., or any regulation adopted thereunder, the Director has the authority to suspend, revoke or refuse to grant or renew the license of a private inspection facility, the Director shall also have the authority to impose, as an alternative or in addition to such suspension, revocation or refusal to grant or renew, an official warning.

(b) The following penalty schedule shall apply to private inspection facilities that violate P.L. 1995, c.112 or this subchapter.

1. For intentionally or willfully improperly passing a vehicle for any required portion of the emission test in violation of rules or procedural requirements:

- i. Six month license suspension; plus \$1,000.00 civil penalty first violation
- ii. Two year license suspension; plus \$5,000.00 civil penalty second violation
- iii. Lifetime license revocation; plus \$7,500.00 civil penalty third violation

2. For gross negligence in passing a vehicle for any required portion of the emission test in violation of rules or procedural requirements:

- i. Six month license suspension; plus \$500.00 civil penalty first violation
- ii. One year license suspension; plus \$1,000.00 civil penalty second violation
- iii. Two year license suspension; plus \$2,000.00 civil penalty third violation
- iv. Lifetime license revocation; plus \$5,000.00 civil penalty fourth violation

3. For simple negligence in passing a vehicle for any required portion of the emission test in violation of rules or procedural requirements:

- i. Six month license suspension; plus \$500.00 civil penalty first violation
- ii. Six month license suspension; plus \$500.00 civil penalty second violation
- iii. One year license suspension; plus \$750.00 civil penalty third violation
- iv. One year license suspension; plus \$750.00 civil penalty fourth violation
- v. Two year license suspension; plus \$1,000.00 civil penalty fifth and subsequent violations

4. For misrepresentation on application (fraud or misrepresentation in securing the license):

- i. Three-year license denial

5. For fraudulently affixing certificate of approval or certificate of waiver:

- i. Immediate two-year license suspension; plus \$500.00 civil penalty first violation
- ii. Immediate four-year license suspension; plus \$1,000.00 civil penalty second violation
- iii. Lifetime license revocation; plus \$2,000.00 civil penalty third violation

6. For fraud or misrepresentation in the conduct of the licensed activity:

- i. Immediate two-year license suspension first violation
- ii. Immediate four-year license suspension second violation
- iii. Lifetime license revocation third violation

7. For issuance or possession of altered, forged, stolen, or counterfeit certificate of approval, certificate of waiver or rejection sticker:

- i. Two-year license suspension first violation
- ii. Four-year license suspension second violation
- iii. Lifetime license revocation third violation

8. For furnishing, lending, giving or selling a certificate of approval, certificate of waiver or rejection sticker without performing the required inspection or reinspection:

- i. Two-year license suspension first violation
- ii. Four-year license suspension second and subsequent violations

9. For failing to produce inspection records:

- i. Immediate license suspension until compliance

10. For unlicensed person performing emission inspection:

- i. Four-month license suspension first violation
- ii. Six-month license suspension second violation
- iii. One-year license suspension third and subsequent violations

11. For fraudulent recordkeeping:

- i. Immediate two-year license suspension first violation
- ii. Immediate four-year license suspension second violation
- iii. Lifetime license revocation third violation

12. For improper recordkeeping:

- i. One-month license suspension first violation
- ii. Two-month license suspension second violation
- iii. Six-month license suspension third and subsequent violations

13. For certifying a vehicle that does not meet State equipment safety standards:

- i. Six-month license suspension first violation
- ii. Six-month license suspension second violation
- iii. One-year license suspension third and subsequent violations

14. For improper security of certificates of approval, certificates of waiver and/or rejection stickers:

- i. Written warning first violation
- ii. Two-month license suspension second violation
- iii. Six-month license suspension third and subsequent violations

15. For lost or stolen certificates of approval, certificates of waiver and/or rejection stickers for which the licensee does not properly account. A licensee can "properly account" for such documents by demonstrating, to the satisfaction of the Director, that they were lost or stolen under circumstances beyond the reasonable control of the licensee:

- i. One-month license suspension; plus \$100.00 civil penalty per certificate first violation
- ii. Two-month license suspension plus \$250.00 civil penalty per certificate second violation

- iii. One-year license suspension plus \$500.00 civil penalty per certificate third and subsequent violations

16. For overcharging on inspection/reinspection:

- i. Written warning first violation
- ii. 30-day license suspension second violation
- iii. 60-day license suspension third and subsequent violations

17. For failing to maintain insurance coverage:

- i. Minimum 15-day license suspension and until compliance

18. For failure to provide vehicle inspection report and/or work order to the customer:

- i. 30-day license suspension first violation
- ii. 60-day license suspension second violation
- iii. One-year license suspension third and subsequent violations

19. For failure to post license:

- i. Written warning first violation
- ii. 20-day license suspension second violation
- iii. Two-month license suspension third and subsequent violations

20. For failure to post outdoor sign:

- i. Written warning first violation
- ii. 20-day license suspension second violation
- iii. Two-month license suspension third and subsequent violations

21. For failure to post hourly rate and/or inspection fees:

- i. Written warning first violation
- ii. 20-day license suspension second violation
- iii. Two-month license suspension third and subsequent violations

22. For failure to pay fee(s):

- i. License suspension until compliance

23. For criminal conviction which is disqualifying:

- i. Indefinite license denial/suspension license issuance/restoration predicated on standards set forth in the Rehabilitated Convicted Offenders Act (N.J.S.A. 2A:168A-1 et seq.).

13:20-44.21 Investigations

(a) The Director, or any person designated by him or her, shall have the power to investigate and gather evidence of violations of N.J.S.A. 39:8-1 et seq., or of any regulation adopted thereunder, by a private inspection facility.

(b) The Director, or any person designated by him or her, shall have the power to conduct investigations, administer oaths, interrogate licensees, issue subpoenas, summonses

and/or complaints and compel witnesses to appear at any hearing.

(c) Except as set forth in N.J.A.C. 13:20-44.12(j), subpoenas shall be served in the same manner, and the witnesses shall be entitled to the same fees, as in the case of subpoenas issued out of the Superior Court of New Jersey.

(d) In the case of a failure of any person to comply with any subpoena issued under these rules or to testify with respect to any matter concerning which he or she may be lawfully interrogated, the Superior Court, on application of the Director, may be requested to issue an order requiring the attendance of such person and the giving of testimony or production of evidence. Any person failing to obey the order of the court may be punished by the court for contempt.

(e) In addition to the authority set forth in (a) above, New Jersey State Police officers, Department of Environmental Protection investigators and Division of Consumer Affairs investigators are hereby authorized to enforce the provisions of this subchapter.

13:20-44.22 Written notice of suspension or revocation or refusal to grant or renew license

(a) The Director shall notify the applicant, in writing by certified mail, of any refusal to grant or renew a private inspection facility license to the applicant and the grounds thereof. Written notice shall be mailed to the applicant at the address listed on the application or to the place of business on record with the Division.

(b) The Director shall notify the licensee, in writing by certified mail, of any proposed suspension or revocation of the private inspection facility license and the grounds thereof. Written notice shall be mailed to the place of business on record with the Division. Unless the licensee files with the Director a written request for a hearing in accordance with N.J.A.C. 13:20-44.23, the private inspection facility license shall be suspended or revoked on the date specified in such notice.

13:20-44.23 Request for hearing

(a) If an applicant has been notified in accordance with N.J.A.C. 13:20-44.22(a) that the Director refuses to grant or renew a private inspection facility license to him or her, the applicant shall be entitled to an administrative hearing concerning such refusal provided that the applicant has filed and the Director has received a written request for a hearing within 15 days. The 15 day period shall commence on the date such notice was mailed to the applicant by the Division in accordance with N.J.A.C. 13:20-44.22(a).

(b) If a license has been notified in accordance with N.J.A.C. 13:20-44.22(b) of a proposed suspension or revocation of his or her private inspection facility license, the licensee shall be entitled to an administrative hearing con-

cerning such proposed suspension or revocation provided that the licensee has filed and the Director has received a written request for a hearing within 15 days. The 15 day period shall commence on the date such notice was mailed to the licensee by the Division in accordance with N.J.A.C. 13:20-44.22(b).

(c) Any written request for a hearing by an applicant or licensee shall be sent to the Private Inspection Facility Licensing Unit of the Division at the address specified in N.J.A.C. 13:20-44.4(a). The hearing request shall contain the following information:

1. The name, license number, place of business and telephone number of the private inspection facility;
2. A concise statement of facts constituting each ground of defense;
3. A specific admission, denial or explanation of each fact alleged by the Division in its notice or order to show cause, or if without knowledge thereof, a statement to that effect; any allegation in the Division's notice or order to show cause which is not answered in accordance with this paragraph shall be deemed to have been admitted; and
4. A statement requesting a hearing.

(d) If the applicant or licensee does not file a written request for a hearing in accordance with (a), (b), or (c) above, the suspension, revocation or refusal to grant or renew the private inspection facility license shall be effective on the date specified in such notice. The private inspection facility shall cease all activities of the business of a private inspection facility effective on the date specified in such notice.

13:20-44.24 Hearing procedures

Any hearing concerning the suspension, revocation or refusal to grant or renew a private inspection facility license shall be conducted in accordance with the Administrative Procedure Act, N.J.S.A. 52:14B-1 et seq., and the Uniform Administrative Procedure Rules, N.J.A.C. 1:1.

13:20-44.25 Limitations on issuance of license after suspension, revocation or refusal to grant or renew

(a) No person whose application for a private inspection facility license is refused shall be entitled to apply for a license under this subchapter for a period of one year from the effective date of such refusal.

(b) No person whose license is suspended or revoked shall be entitled to apply for a license under this subchapter during the period of suspension or revocation.

13:20-44.26 License restoration

(a) A fee of \$50.00 shall be payable to the Division for the restoration of a private inspection facility license which is suspended or revoked pursuant to N.J.S.A. 39:8-1 et seq. or this subchapter. Such license restoration fee shall be paid to the Division before the license may be restored.

(b) Each suspension or revocation of any private inspection facility license, pursuant to N.J.S.A. 39:8-1 et seq. or any regulation adopted thereunder, shall continue in force and effect until such license is restored by the Director.

(c) In the case of every suspension or revocation of a private inspection facility license for a fixed period of time, the licensee, as a condition precedent to restoration, shall make application to the Director, in such form as the Director may determine, and pay the license restoration fee specified in (a) above. The Director may, upon notice and an opportunity to be heard, deny any application for restoration of a private inspection facility license for good cause.

SUBCHAPTER 45. MOTOR VEHICLE EMISSION REPAIR FACILITY REGISTRATION

Authority

P.L. 1995, c.112, N.J.S.A. 39:2-3, 39:3-43, 39:8-4.1, 42 U.S.C. § 7401 et seq. and 40 C.F.R. § 51.350 et seq.

Source and Effective Date

R.1995 d.528, effective August 28, 1995.
See: 27 N.J.R. 2777(a), 27 N.J.R. 3820(a).

Subchapter Historical Note

Subchapter 45, Motor Vehicle Emission Repair Facility Registration, was adopted as Emergency New Rules by R.1995 d.410, effective June 29, 1995, to expire August 28, 1995. See: 27 N.J.R. 2777(a). The concurrent proposal of Subchapter 45 was adopted as R.1995 d.528, effective August 28, 1995. See: Source and Effective Date. See, also, section annotations.

13:20-45.1 Purpose

P.L.1995, c.112 provides for the registration of motor vehicle emission repair facilities by the Director of the Division of Motor Vehicles. The purpose of this subchapter is to establish a system for the registration of motor vehicle emission repair facilities which perform emission repairs for compensation on motor vehicles which have failed an emission inspection so that the Division may track emission repairs for monitoring purposes and document emission repair costs for purposes of issuance of certificates of waiver.

13:20-45.2 Scope

(a) This subchapter shall apply to every person engaged in the business of a motor vehicle emission repair facility.

(b) No person shall, on or after June 29, 1995, engage in the business of a motor vehicle emission repair facility unless registered by the Director in accordance with the provisions of this subchapter.

13:20-45.3 Definitions

The following words and terms, when used in this subchapter, shall have the following meanings, unless the context clearly indicates otherwise:

“Advertising” means any printed or published materials including, but not limited to, direct mail, circulars, leaflets, pamphlets, newspapers, magazines, billboards, yellow pages of any telephone directory, radio and/or television broadcasts, and any other advertising medium of communication used to induce the public to seek the services of the motor vehicle emission repair facility. The term “advertising” shall not include printed or published materials appearing in the white pages of any telephone directory.

“Applicant” means any person applying under the provisions of this subchapter for an initial registration to engage in the business of a motor vehicle emission repair facility or to renew an existing registration. In the case of a partnership or corporation applying for a registration, the term “applicant” shall respectively include all partners and/or officers and directors and/or persons having a controlling interest in a sole proprietorship or corporation.

“Controlling interest” means possession of the power to direct or cause the direction of the management and policies of a motor vehicle emission repair facility, whether through the ownership of voting securities or otherwise. The Director will presume that control in fact exists if any person or entity directly or indirectly owns, controls, holds the power to vote, or holds proxies representing 10 percent or more of the voting securities of any motor vehicle emission repair facility. This presumption may be rebutted by showing that control does not in fact exist. The Director may determine that control in fact exists, notwithstanding the presence or absence of a presumption to that effect.

“Customer” means the owner of record of a motor vehicle on file with the Division, or any family member, employee or any other person whose use of the motor vehicle is authorized by such owner of record.

“Department” means the Department of Environmental Protection in the State of New Jersey.

“Director” means the Director of the Division of Motor Vehicles in the Department of Transportation in the State of New Jersey.

“Division” means the Division of Motor Vehicles in the Department of Transportation in the State of New Jersey.

“Emission repair facility registration” means a registration issued to a motor vehicle emission repair facility which

evidences the Director’s authorization for the facility to engage in emission repairs on motor vehicles which have failed an emission inspection.

“Engaged in the business” means performing emission-related repair(s) for compensation and includes:

1. Any person performing emission repair(s) on motor vehicles that have failed an emission inspection required by the Director;
2. Any person who subcontracts or has any type of business arrangement with a motor vehicle emission repair facility or other person to perform emission repairs on motor vehicles that have failed an emission inspection required by the Director;
3. Any person who prepares an estimate to be used by a motor vehicle emission repair facility or other person to perform emission repairs on motor vehicles that have failed an emission inspection required by the Director; or
4. Any person who negotiates in any manner with any customer to perform emission repairs on motor vehicles that have failed an emission inspection required by the Director.

“Estimate” means any written determination prepared by a motor vehicle emission repair facility of the approximate cost of the parts and labor needed to perform the requested repair services.

“Federal Clean Air Act” means the federal “Clean Air Act,” 42 U.S.C. §7401 et seq., and any subsequent amendments or supplements to that act.

“Motor vehicle emission repair facility” means any person who for compensation engages in the business of repairing motor vehicles that have failed an emission inspection required by the Director. For the purpose of this subchapter, the following are not deemed to be a motor vehicle emission repair facility and are not required to be registered:

1. Any employee of a motor vehicle emission repair facility who engages in the business of repairing motor vehicles that have failed an emission inspection solely by reason of his or her employment;
2. Any person who is solely engaged in the business of repairing motor vehicles that have failed an emission inspection and who is employed by a single commercial or industrial establishment that is the owner or lessor of such vehicles; or
3. Any person whose activities consist solely of fueling, changing oil, water, batteries or tires, replacing fan belts, air filters or oil filters, installing windshield wiper blades, light bulbs, communication equipment, or such other repair and servicing functions that are not related to motor vehicle emission inspection failures.

"Person" means any natural person, business, company, firm, partnership, association, corporation or any other entity.

"Place of business" means the address or location where the services of a motor vehicle emission repair facility are offered or ordinarily performed.

"Suspension, revocation or refusal to renew" means administrative action by the Director, in accordance with the provisions of P.L. 1995, c.112 or this subchapter, to refuse to renew a motor vehicle emission repair facility registration or to suspend or revoke a registration.

13:20-45.4 Initial application for registration

(a) Any person seeking to engage in the business of a motor vehicle emission repair facility shall apply, in accordance with the provisions of this subchapter, to the Director for a registration authorizing him or her to engage in such business. An application for a motor vehicle emission repair facility registration may be obtained from the Motor Vehicle Emission Repair Facility Registration Unit of the Division. The address of the Motor Vehicle Emission Repair Facility Registration Unit is:

Division of Motor Vehicles
Business License Compliance
Motor Vehicle Emission Repair Facility Registration Unit
225 East State Street
CN 170
Trenton, New Jersey 08666-0170

(b) Each applicant for a motor vehicle emission repair facility registration shall file with the Director, in such form and detail as may be required by him or her, an application setting forth the following:

1. The name, place of business and telephone number of the motor vehicle emission repair facility;
2. The name, business and residence address(es), driver's license number, social security number and telephone number(s) of:
 - i. The owner and/or possessor of a controlling interest of the facility, in the case of a sole proprietorship;
 - ii. Each partner, in the case of a partnership; or
 - iii. Each officer, director and possessor of a controlling interest, in the case of a corporation;
3. Whether the applicant has ever been convicted of a crime;
4. Whether the applicant has ever been found to be in violation of the Federal Clean Air Act or the Consumer Fraud Act (N.J.S.A. 56:8-1 et seq.) or any regulations adopted thereunder or N.J.A.C. 7:27-15.7 pertaining to tampering with emission control apparatus;

5. Whether the applicant has ever been denied, or had suspended or revoked, a license or registration to engage in any business, profession or occupation licensed or registered under the laws of any state; and

6. Whether the applicant has any interest in any other motor vehicle emission repair facility or any motor vehicle related business.

(c) Each initial application for a motor vehicle emission repair facility registration shall include the following:

1. The New Jersey Sales Tax Identification Number;
2. The New Jersey Unemployment Registration Number;
3. The Federal Employer Identification Number; and
4. The corporation code, if one has been issued by the Division.

(d) Each initial application for a motor vehicle emission repair facility registration shall be accompanied by the applicable fee as specified in N.J.A.C. 13:20-45.6.

(e) If there are multiple locations for motor vehicle emission repair facilities owned by the same applicant, a separate application, accompanying documents, and registration fee as specified in N.J.A.C. 13:20-45.6 shall be submitted for each such place of business. A separate registration shall be issued for each such place of business.

(f) Upon preliminary approval of each initial registration application, a registration shall be issued to the motor vehicle emission repair facility. Each initial registration issued to a motor vehicle emission repair facility on or after June 29, 1995 shall be effective on the date of issuance and shall continue in force and effect until December 31, 1998, and shall, thereafter, be renewed on a biennial basis, unless such registration is suspended or revoked by the Director.

13:20-45.5 Applicant qualification

Each applicant shall be at least 18 years old, and must have the legal capacity to contract, to be sued and to be liable for all debts.

13:20-45.6 Registration fee

Each initial or renewal application for a motor vehicle emission repair facility registration shall be accompanied by a registration fee of \$50.00 payable to the Division. Such registration fee shall be returned to the applicant only in the event that the Director refuses to grant or renew a motor vehicle emission repair facility registration. Such registration fee, or any portion thereof, shall not be refunded to the registrant in the event that the motor vehicle emission repair facility registration is suspended or revoked pursuant to N.J.S.A. 39:8-1 et seq. or this subchapter, or if the registrant voluntarily surrenders the registration at any time during the registration period.

13:20-45.7 Registration renewals

(a) Each registrant shall, no later than 30 days before the expiration of the registration, submit to the Director an application to renew its current registration provided that such registrant is not prohibited from applying for a registration as specified in N.J.A.C. 13:20-45.22. An application to renew a motor vehicle emission repair facility registration may be obtained from the Motor Vehicle Emission Repair Facility Registration Unit of the Division at the address specified in N.J.A.C. 13:20-45.4(a).

(b) Each application to renew a motor vehicle emission repair facility registration shall be accompanied by the fee specified in N.J.A.C. 13:20-45.6.

(c) Upon approval of each renewal application, a registration shall be issued to the motor vehicle emission repair facility. Each renewal registration issued to a motor vehicle emission repair facility after December 31, 1998 shall continue in force and effect for a period of two years unless such registration is suspended or revoked by the Director.

13:20-45.8 Surrender of registration

(a) Each motor vehicle emission repair facility registration, although issued and delivered to a registrant, shall at all times be the property of the State of New Jersey.

(b) Upon any suspension, revocation, refusal to renew or other termination of a motor vehicle emission repair facility registration, the registration shall no longer be in force and effect and the registration shall be surrendered forthwith upon demand of a Division representative.

13:20-45.9 Responsibility of registrants

(a) In the case of a sole proprietorship, the owner and/or possessor of a controlling interest in the motor vehicle emission repair facility shall be responsible to the Director for the conduct of the business of the facility and for all actions performed by his or her employees in connection with the business of the facility concerning violations of P.L. 1995, c.112 or this subchapter.

(b) In the case of a partnership or corporation, each partner, or corporate officer and/or director, or any person or entity possessing a controlling interest, as the case may be, shall be held individually and jointly responsible to the Director for the conduct of the business of the facility and for all actions performed by its employees in connection with the business of the facility concerning violations of P.L. 1995, c.112 or this subchapter.

13:20-45.10 Deceptive practices concerning emission-related repairs

Motor vehicle emission repair facilities shall be subject to the provisions of N.J.A.C. 13:45A-7.

13:20-45.11 Notice and recordkeeping requirements

(a) Each registrant shall display an outdoor sign which shall read: "Registered: State of New Jersey Motor Vehicle Emission Repair Facility". The sign shall include the registration number of the motor vehicle emission repair facility. The sign must contain letters at least two inches high with a stroke of approximately one-half inch, be visible from the road and be located in a conspicuous location for the general public to see. If zoning ordinances prohibit the posting of such sign or such posting is otherwise impractical, the registrant shall prominently display such sign on the exterior of the motor vehicle emission repair facility.

(b) Every registration issued in accordance with this subchapter shall be prominently displayed in the office, waiting area or other conspicuous location which is accessible to the public at the motor vehicle emission repair facility.

(c) Every registered motor vehicle emission repair facility shall post in a conspicuous location accessible to the public a "Notice to Consumers" concerning violations of P.L. 1995, c.112 and the fact that customers have a right to inspect the repaired motor vehicle before paying for the repair work. The notice shall be prepared and furnished by the Division.

(d) Every registered motor vehicle emission repair facility shall post in a conspicuous location accessible to the public a notice stating that the names and qualifications of its certified emission repair technicians are available upon request.

(e) Every registered motor vehicle emission repair facility shall maintain copies of all motor vehicle inspection reports, estimates, work orders, invoices, parts purchase orders, appraisals and/or other documents prepared by that facility for repair work performed by that facility or by subcontractors.

1. Such copies shall be kept for at least four years and shall be available for inspection by the Director, the Commissioner of the Department of Environmental Protection, the Director of the Division of Consumer Affairs, or any person designated by them, during normal business hours.

2. Failure to permit such inspection shall subject the registrant to administrative action pursuant to this subchapter.

(f) Every motor vehicle emission repair facility shall, upon request of the Director or any person designated by him or her, provide the Director or his or her designee with a list of its employees in such form and detail as may be required by the Director or his or her designee. Failure to provide such list when requested shall subject the registrant to administrative action pursuant to this subchapter.

(g) The registrant shall notify the Director in writing within 10 days whenever any person acquires ownership or control of 10 percent or more of the stock of a motor vehicle emission repair facility, or whenever a person be-

comes a partner or limited partner in a motor vehicle repair facility.

(h) The registrant shall notify the Director in writing within 10 days of any change in address of the motor vehicle emission repair facility or of any change in address of persons or entities required to be listed on the application by N.J.A.C. 13:20-45.4.

(i) The registrant shall notify the Director in writing within 10 days whenever any person or entity required to be listed on the application by N.J.A.C. 13:20-45.4 is no longer associated with the motor vehicle emission repair facility.

(j) All written notifications required by this subchapter shall be made by either personal delivery or sent by certified mail to the Motor Vehicle Emission Repair Facility Registration Unit of the Division at the address specified in N.J.A.C. 13:20-45.4(a).

(k) An amended application shall be filed by the registrant with the Director when there is a substitution and/or addition of persons or entities required to be listed on the application by N.J.A.C. 13:20-45.4.

(l) Any process issued to a registrant pursuant to the statutory authority of the Director including, but not limited to, subpoenas, orders, and orders to show cause, may be served upon a registrant or counsel of record, by sending said process by certified or ordinary mail, to the business address of the motor vehicle emission repair facility or to counsel's address on record with the Division.

13:20-45.12 Advertising

(a) Any advertising used by the motor vehicle emission repair facility in any printed or published material shall contain and prominently display the registration number of the facility.

(b) Any advertising used by the motor vehicle emission repair facility in any radio broadcast shall disclose that the facility is registered by the State of New Jersey.

(c) Any advertising used by the motor vehicle emission repair facility in any television broadcast shall prominently display the registration number of the facility at the end of such broadcast.

13:20-45.13 Storage rates

Every motor vehicle emission repair facility which charges a per diem fee to store a motor vehicle on its premises shall disclose in writing, prior to initiating emission-related repair(s), the amount of such storage charge to the customer.

13:20-45.14 Additional violations

(a) In addition to any violation of N.J.S.A. 39:8-1 et seq., the Director may refuse to renew a registration or suspend or revoke the registration of any motor vehicle emission repair facility if he or she determines that the applicant or registrant:

1. Has made a false statement or concealed a fact in connection with the application for a registration or a renewal thereof; or

2. Is not the owner of, or possessor of a controlling interest in, the motor vehicle repair facility.

(b) In addition to any violation of N.J.S.A. 39:8-1 et seq., the Director may refuse to renew a registration or suspend or revoke the registration of any motor vehicle emission repair facility if he or she determines that the applicant or registrant at any time following submission of the application for initial registration:

1. Has been found to have violated or conducted fraudulent or deceptive practices concerning the repair of motor vehicles in violation of N.J.S.A. 56:8-1 et seq. or N.J.A.C. 13:45A-7 or this subchapter;

2. Has been found to have violated N.J.A.C. 7:27-15.7 pertaining to tampering with emission control apparatus;

3. Has a criminal record which is disqualifying. A disqualifying criminal record shall include a conviction of any offense in any jurisdiction which indicates that registration of the applicant or continued registration of the registrant would be inimical to the registration standards set forth in P.L. 1995, c.112 and this subchapter;

4. Demonstrates a pattern of conduct whereby emission repairs made by the motor vehicle emission repair facility were not made in a workmanlike manner;

5. Issues a check in payment of any fees required by this subchapter which is subsequently dishonored;

6. Has failed to comply with any of the provisions of this subchapter;

7. Fails to maintain an approved place of business in accordance with N.J.A.C. 13:20-45.4(b)(1);

8. Fails to pay any fee required by law or regulation;

9. Fails to notify the Director in writing as required by N.J.A.C. 13:20-45.11(f), (g) and (h);

10. Has in its possession any motor vehicle, major motor vehicle component part or component part as defined in N.J.S.A. 39:10B-1 or replacement parts on which the vehicle identification number or other identification affixed thereto in accordance with Federal theft prevention standards has been removed, altered, defaced, destroyed, or so covered as to be concealed;

11. Has been found to be in violation of the Federal Clean Air Act or the Consumer Fraud Act (N.J.S.A. 56:8-1 et seq.) or any regulations adopted thereunder;

12. Has failed to properly secure Pre-inspection Emission Repair Forms;

13. Has failed to properly account for lost or stolen Pre-inspection Emission Repair Forms. A registrant can "properly account" for such documents by demonstrating, to the satisfaction of Director, that they were lost or stolen under circumstances beyond the reasonable control of the registrant; or

14. For other good cause.

13:20-45.15 Mechanic qualifications

If the motor vehicle emission repair facility performs safety equipment repairs, the registrant or someone in his or her employment must meet the mechanic qualification standard as set forth in N.J.A.C. 13:20-44.19.

13:20-45.16 Repair technician; certification

(a) On or after July 1, 1998, the registrant or someone in his or her employment shall be certified as a repair technician.

(b) On or after July 1, 1998, no emission repairs may be performed for compensation of any kind by any person or facility unless the repairs are made by, or under the supervision of, a certified repair technician employed by the facility. For purposes of this subsection "employed by" shall be construed to include any business relationship between the certified repair technician and the facility including actual or equitable ownership, in whole or in part, of the individual facility by the technician or a partnership interest in the facility.

(c) Repair technician certification shall be predicated upon a person's satisfactory completion of an approved repair technician certification program of instruction in emission-related repairs on vehicles that fail an emission test.

(d) An approved repair technician program of instruction shall include:

1. Diagnosis and repair of malfunctions in computer controlled, close-loop vehicles;
2. The application of emission control theory and diagnostic data to the diagnosis and repair of failures on loaded-mode and idle tests and the evaporative system functional tests;
3. Utilization of diagnostic information on systematic or repeated failures observed in the loaded-mode and idle tests and the evaporative system functional tests; and
4. General training in the various subsystems related to engine emission control.

(e) Upon the satisfactory completion of a course of instruction, the provider of the repair technician program shall issue to each person a Certificate of Repair Technician Course Completion.

13:20-45.17 Additional penalties

Where, pursuant to N.J.S.A. 39:8-1 et seq., or any regulation adopted thereunder, the Director has the authority to suspend, revoke or refuse to renew the registration of a motor vehicle emission repair facility, the Director shall also have the authority to impose, as an alternative or in addition to such suspension, revocation or refusal to renew, an official warning.

13:20-45.18 Investigations

(a) The Director, or any person designated by him or her, shall have the power to investigate and gather evidence of violations of N.J.S.A. 39:8-1 et seq., or of any regulation adopted thereunder, by a motor vehicle emission repair facility.

(b) The Director, or any person designated by him or her, shall have the power to conduct investigations, administer oaths, interrogate registrants, issue subpoenas, summonses and/or complaints and compel witnesses to appear at any hearing.

(c) Except as set forth in N.J.A.C. 13:20-45.11(k), subpoenas shall be served in the same manner, and the witnesses shall be entitled to the same fees, as in the case of subpoenas issued out of the Superior Court of New Jersey.

(d) In the case of a failure of any person to comply with any subpoena issued under this subchapter or to testify with respect to any matter concerning which he or she may be lawfully interrogated, the Superior Court, on application of the Director, may be requested to issue an order requiring the attendance of such person and the giving of testimony or production of evidence. Any person failing to obey the order of the court may be punished by the court for contempt.

(e) In addition to the authority set forth in (a) above, New Jersey State Police officers, Department of Environmental Protection investigators and Division of Consumer Affairs investigators are hereby authorized to enforce the provisions of this subchapter.

13:20-45.19 Written notice of suspension or revocation or refusal to grant or renew registration

(a) The Director shall notify the applicant, in writing by certified mail, of any refusal to renew a motor vehicle emission repair facility registration and the grounds thereof. Written notice shall be mailed to the applicant at the address listed on the application or to the place of business on record with the Division.

(b) The Director shall notify the registrant, in writing by certified mail, of any proposed suspension or revocation of the motor vehicle emission repair facility registration and the grounds thereof. Written notice shall be mailed to the place of business on record with the Division. Unless the registrant files with the Director a written request for a

hearing in accordance with N.J.A.C. 13:20-45.20, the motor vehicle emission repair facility registration shall be suspended or revoked on the date specified in such notice.

13:20-45.20 Request for hearing

(a) If an applicant has been notified in accordance with N.J.A.C. 13:20-45.19(a) that the Director refuses to renew a motor vehicle emission repair facility registration, the applicant shall be entitled to an administrative hearing concerning such refusal provided that the applicant has filed and the Director has received a written request for a hearing within 15 days. The 15 day period shall commence on the date such notice was mailed to the applicant by the Division in accordance with N.J.A.C. 13:20-45.19(a).

(b) If a registrant has been notified in accordance with N.J.A.C. 13:20-45.19(b) of a proposed suspension or revocation of his or her motor vehicle emission repair facility registration, the registrant shall be entitled to an administrative hearing concerning such proposed suspension or revocation provided that the registrant has filed and the Director has received a written request for a hearing within 15 days. The 15 day period shall commence on the date such notice was mailed to the registrant by the Division in accordance with N.J.A.C. 13:20-45.19(b).

(c) Any written request for a hearing by an applicant or registrant shall be sent to the Motor Vehicle Emission Repair Facility Registration Unit of the Division at the address specified in N.J.A.C. 13:20-45.4(a). The hearing request shall contain the following information:

1. The name, registration number, place of business and telephone number of the motor vehicle emission repair facility;
2. A concise statement of facts constituting each ground of defense;
3. A specific admission, denial or explanation of each fact alleged by the Division in its notice or order to show cause, or if without knowledge thereof, a statement to that effect; any allegation in the Division's notice or order to show cause which is not answered in accordance with this paragraph shall be deemed to have been admitted; and
4. A statement requesting a hearing.

(d) If the applicant or registrant does not file a written request for a hearing in accordance with (a), (b), or (c) above, the suspension, revocation or refusal to renew the motor vehicle emission repair facility registration shall be effective on the date specified in such notice. The motor vehicle emission repair facility shall cease all activities of the business of a motor vehicle emission repair facility effective on the date specified in such notice.

13:20-45.21 Hearing procedures

Any hearing concerning the suspension, revocation or refusal to renew a motor vehicle emission repair facility registration shall be conducted in accordance with the Administrative Procedure Act, N.J.S.A. 52:14B-1 et seq., and the Uniform Administrative Procedure Rules, N.J.A.C. 1:1.

13:20-45.22 Limitations on issuance of registration after suspension, revocation or refusal to renew

(a) No person whose renewal application for a motor vehicle emission repair facility registration is refused shall be entitled to apply for a registration under this subchapter for a period of one year from the effective date of such refusal.

(b) No person whose registration is suspended or revoked shall be entitled to apply for a registration under this subchapter during the period of suspension or revocation.

13:20-45.23 Registration restoration

(a) A fee of \$50.00 shall be payable to the Division for the restoration of a motor vehicle emission repair facility registration which is suspended or revoked pursuant to N.J.S.A. 39:8-1 et seq. or this subchapter. Such registration restoration fee shall be paid to the Division before the registration may be restored.

(b) Each suspension or revocation of any motor vehicle emission repair facility registration, pursuant to N.J.S.A. 39:8-1 et seq. or any regulation adopted thereunder, shall continue in force and effect until such registration is restored by the Director.

(c) In the case of every suspension or revocation of a motor vehicle emission repair facility registration for a fixed period of time, the registrant, as a condition precedent to restoration, shall make application to the Director, in such form as the Director may determine, and pay the registration restoration fee specified in (a) above. The Director may, upon notice and an opportunity to be heard, deny any application for restoration of a motor vehicle emission repair facility registration for good cause.