

NEW JERSEY STATE LIBRARY

CHAPTER 9A

**STANDARDS FOR INDIVIDUAL SUBSURFACE
SEWAGE DISPOSAL SYSTEMS**

Authority

N.J.S.A. 58:11-23 et seq.; 58:10A-1 et seq., including 58:10A-16 et seq.; 13:1D-1 et seq.; and 26:3A-21 et seq.

Source and Effective Date

R.1994 d.469, effective August 18, 1994.
See: 26 N.J.R. 2715(a), 26 N.J.R. 3829(a).

Executive Order No. 66(1978) Expiration Date

Chapter 9A, Standards for Individual Subsurface Sewage Disposal Systems, expires on August 18, 1999.

Chapter Historical Note

Chapter 9A, Standards for Individual Subsurface Sewage Disposal Systems, was adopted as R.1989 d.450 and replaced N.J.A.C. 7:9-2 (Standards for Construction of Individual Subsurface Sewage Disposal Systems), effective August 21, 1989, but not operative until January 1, 1990. See: 20 N.J.R. 1790(a), 21 N.J.R. 2534(a). Notice of Receipt of Petition to amend the standards for individual subsurface sewage disposal systems. See: 23 N.J.R. 622(a).

Pursuant to Executive Order No. 66(1978), Chapter 9A was readopted as R.1994 d.469. See: Source and Effective Date. See, also, section annotations.

CHAPTER TABLE OF CONTENTS

SUBCHAPTER 1. GENERAL PROVISIONS

- 7:9A-1.1 Purpose
- 7:9A-1.2 Scope
- 7:9A-1.3 Construction of rules
- 7:9A-1.4 Practice where rules do not govern
- 7:9A-1.5 Severability
- 7:9A-1.6 General prohibitions
- 7:9A-1.7 Penalties
- 7:9A-1.8 Limitations

SUBCHAPTER 2. DEFINITIONS

- 7:9A-2.1 Definitions

SUBCHAPTER 3. ADMINISTRATION

- 7:9A-3.1 Ordinances
- 7:9A-3.2 New system design approvals
- 7:9A-3.3 Existing systems
- 7:9A-3.4 Malfunctioning systems
- 7:9A-3.5 Permit to construct or alter
- 7:9A-3.6 Witnessing of soil evaluation and testing
- 7:9A-3.7 Modification of plans
- 7:9A-3.8 Pinelands area approvals
- 7:9A-3.9 Treatment works approval
- 7:9A-3.10 NJPDES permits
- 7:9A-3.11 Experimental systems
- 7:9A-3.12 Holding tanks
- 7:9A-3.13 Certificate of compliance
- 7:9A-3.14 Notification of proper operation and maintenance practices
- 7:9A-3.15 Records
- 7:9A-3.16 Prior tests
- 7:9A-3.17 Registration of personnel

- 7:9A-3.18 Additional requirements for certification of sewerage facilities serving subdivisions involving more than 10 realty improvements
- 7:9A-3.19 Entry and inspection
- 7:9A-3.20 Hearing procedures

SUBCHAPTER 4. SITE EVALUATION AND SYSTEM LOCATION

- 7:9A-4.1 General provisions for site evaluation and system location
- 7:9A-4.2 Location generally
- 7:9A-4.3 Distances
- 7:9A-4.4 Slope
- 7:9A-4.5 Surface drainage
- 7:9A-4.6 Surface flooding
- 7:9A-4.7 Freshwater wetlands
- 7:9A-4.8 Area reserved for sewage disposal

SUBCHAPTER 5. DETERMINATION OF SOIL SUITABILITY

- 7:9A-5.1 General provisions for the determination of soil suitability
- 7:9A-5.2 Requirements for soil profile pits and borings
- 7:9A-5.3 Terminology required for soil logs
- 7:9A-5.4 Criteria for determination of soil suitability classes
- 7:9A-5.5 Rock substrata
- 7:9A-5.6 Excessively coarse horizons and substrata
- 7:9A-5.7 Hydraulically restrictive horizons and substrata
- 7:9A-5.8 Criteria for recognition of zones of saturation
- 7:9A-5.9 Hydraulic head test
- 7:9A-5.10 Disturbed ground

SUBCHAPTER 6. PERMEABILITY TESTING

- 7:9A-6.1 General provisions for permeability testing
- 7:9A-6.2 Tube permeameter test
- 7:9A-6.3 Soil permeability class rating
- 7:9A-6.4 Percolation test
- 7:9A-6.5 Pit bailing test
- 7:9A-6.6 Piezometer test
- 7:9A-6.7 Basin flooding test

SUBCHAPTER 7. GENERAL DESIGN AND CONSTRUCTION REQUIREMENTS

- 7:9A-7.1 Design requirements
- 7:9A-7.2 Construction
- 7:9A-7.3 Type of wastes
- 7:9A-7.4 Volume of sanitary sewage
- 7:9A-7.5 Separate disposal of greywater and blackwater
- 7:9A-7.6 Type of system
- 7:9A-7.7 Building sewer

SUBCHAPTER 8. PRETREATMENT UNITS

- 7:9A-8.1 Grease traps
- 7:9A-8.2 Septic tanks

SUBCHAPTER 9. EFFLUENT DISTRIBUTION NETWORKS

- 7:9A-9.1 General requirements for effluent distribution
- 7:9A-9.2 Dosing tanks
- 7:9A-9.3 Connecting pipes and delivery pipes
- 7:9A-9.4 Distribution boxes
- 7:9A-9.5 Laterals; gravity distribution
- 7:9A-9.6 Pressure dosing networks
- 7:9A-9.7 Design procedure for pressure dosing systems

SUBCHAPTER 10. DISPOSAL FIELDS

- 7:9A-10.1 General design requirements for disposal fields
- 7:9A-10.2 Disposal field sizing requirements
- 7:9A-10.3 Specific requirements for conventional disposal field installations
- 7:9A-10.4 Specific requirements for soil replacement disposal field installations
- 7:9A-10.5 Specific requirements for mounded disposal field installations
- 7:9A-10.6 Specific requirements for mounded soil replacement disposal field installations
- 7:9A-10.7 Interceptor drains

SUBCHAPTER 11. SEEPAGE PITS

- 7:9A-11.1 Site/soil requirements
- 7:9A-11.2 Design requirements
- 7:9A-11.3 Construction requirements

SUBCHAPTER 12. OPERATION AND MAINTENANCE

- 7:9A-12.1 System use
- 7:9A-12.2 through 7:9A-12.6 (Reserved)
- 7:9A-12.7 System testing
- 7:9A-12.8 Abandoned systems

APPENDIX A FIGURES 1 THROUGH 26**APPENDIX B STANDARD FORMS FOR SUBMISSION OF SOILS/ENGINEERING DATA****APPENDIX C UNIFORM PLACEMENT OF PERCOLATION TESTS****APPENDIX D SOIL SUITABILITY CLASSIFICATION OF NEW JERSEY SOILS****SUBCHAPTER 1. GENERAL PROVISIONS****7:9A-1.1 Purpose**

(a) The purpose of this chapter is to:

1. Prevent pollution of the waters of the State that results from improper location, design, construction, installation, alteration, operation or maintenance of individual subsurface sewage disposal systems;
2. Provide standards for the proper location, design, construction, installation, alteration, repair and operation of individual subsurface sewage disposal systems;
3. Protect the public health and safety and the environment;
4. Protect potable water supplies; and
5. Safeguard fish and aquatic life and ecological values.

Amended by R.1993 d.294, effective June 21, 1993.
See: 24 N.J.R. 1987(a), 25 N.J.R. 2704(b).

7:9A-1.2 Scope

(a) This chapter prescribes standards for the location, design, construction, installation, alteration, repair and operation of individual subsurface sewage disposal systems.

(b) Except as otherwise provided by N.J.S.A. 58:11-25, the following shall constitute the rules of the New Jersey Department of Environmental Protection and shall be regarded as uniform standards, in force throughout the State, governing individual subsurface sewage disposal systems.

Amended by R.1993 d.294, effective June 21, 1993.
See: 24 N.J.R. 1987(a), 25 N.J.R. 2704(b).

7:9A-1.3 Construction of rules

(a) This chapter shall be liberally construed to permit the Department to discharge its statutory functions.

(b) All appendices attached to this chapter are incorporated into this chapter and are made a part hereof.

7:9A-1.4 Practice where rules do not govern

The Commissioner, or any other appropriate management employee within the Department, shall exercise his or her discretion in respect to any matters not governed by this chapter.

Amended by R.1994 d.469, effective September 19, 1994.
See: 26 N.J.R. 2715(a), 26 N.J.R. 3829(a).

7:9A-1.5 Severability

If any provision of this chapter or the application thereof to any person or circumstance is held invalid, such invalidity shall not affect other provisions of this chapter, and to this end, the provisions of this chapter are declared to be severable.

7:9A-1.6 General prohibitions

(a) A person shall not install, construct, alter or repair an individual subsurface sewage disposal system without first obtaining the necessary permits, approvals or certifications as required by this chapter.

(b) An administrative authority shall not issue an approval, permit or certification for installation, construction, alteration, or repair of an individual subsurface sewage disposal system where such installation, construction, alteration or repair will violate or otherwise not be in compliance with the requirements of this chapter.

(c) The use of a subsurface sewage disposal system for more than one property, dwelling unit, commercial unit or other premises is prohibited unless a treatment works approval or a NJPDES permit has been issued by the Department.

(d) Individual subsurface sewage disposal systems shall not be located, designed, constructed, installed, altered, repaired or operated in a manner that will allow the discharge of an effluent onto the surface of the ground or into any water course.

(e) The administrative authority shall not approve the construction or alteration of individual subsurface sewage disposal systems or other means of private sewage disposal where a sanitary sewer line is available within 100 feet of the property to be served. For the purpose of this subsection, an existing sanitary sewer line shall be considered to be available when the following conditions are met:

1. Connection of the facility to the sanitary sewer line may be accomplished without installing a pump station, blasting bedrock, acquiring an easement or right-of-way to cross an adjoining property, or crossing a watercourse, railway, major highway or other significant obstacle; and
2. The property to be served is located within the designated sewerage service area of the sewage treatment plant to which the sanitary sewer line is connected.

(f) The discharge of sanitary sewage or the effluent from any individual subsurface sewage disposal system into any abandoned well or any well constructed for the purpose of sanitary sewage disposal is prohibited. The administrative authority shall not approve the discharge of sanitary sewage or septic tank effluent into an existing well or the construction of a new well for the purpose of waste disposal.

(g) The construction or installation of cesspools is prohibited. Alterations, repairs, and/or corrections to cesspools shall, at a minimum, include placement of a septic tank sized in conformance with N.J.A.C. 7:9A-8.2 before the point of discharge into the cesspool.

(h) The administrative authority shall not approve the construction or installation of seepage pits except as provided by N.J.A.C. 7:9A-7.6.

(i) The discharge of industrial wastes into an individual subsurface sewage disposal system is prohibited unless such discharge has been authorized by a treatment works approval or a NJPDES permit issued by the Department.

(j) The administrative authority shall not approve the construction, installation or alteration of any individual subsurface sewage disposal system used for the discharge of industrial wastes.

Amended by R.1993 d.294, effective June 21, 1993.
See: 24 N.J.R. 1987(a), 25 N.J.R. 2704(b).

7:9A-1.7 Penalties

Violation of any provision of this chapter shall be a violation of the New Jersey Water Pollution Control Act, N.J.S.A. 58:10A-1 et seq., and the violator shall be subject

to assessment of civil administrative penalties pursuant to the provisions of N.J.A.C. 7:14-8.

Amended by R.1993 d.294, effective June 21, 1993.
See: 24 N.J.R. 1987(a), 25 N.J.R. 2704(b).

7:9A-1.8 Limitations

(a) The administrative authority shall not approve the installation, construction or alteration of an individual subsurface sewage disposal system unless the proposed system falls within the limits defined as follows:

1. Systems serving one single family home on one individual property; or
2. Systems serving facilities other than single family homes where the total daily volume of sewage generated, calculated as prescribed in N.J.A.C. 7:9A-7.4, is no greater than 2,000 gallons per day, the type of waste discharged consists of sanitary sewage only, and the system is connected to a single building, commercial unit or other realty improvement on the same individual property.

(b) When an individual subsurface sewage disposal system exceeds the limitations in (a) above, a treatment works approval issued by the Department will be required, except under the circumstances specified in N.J.A.C. 7:9A-3.3(f), and a NJPDES permit may also be required.

(c) In cases where the actual volume of sanitary sewage discharged from a facility will be reduced by use of water-saving plumbing fixtures, recycling of renovated wastewater, incineration or composting of wastes, evaporation of sewage effluent or any other process, the requirement for obtaining a treatment works approval and a NJPDES permit shall be based upon the design volume of sanitary sewage, calculated as prescribed in N.J.A.C. 7:9A-7.4, rather than the actual discharge volume as modified by water conservation or special treatment processes.

Amended by R.1994 d.469, effective September 19, 1994.
See: 26 N.J.R. 2715(a), 26 N.J.R. 3829(a).

SUBCHAPTER 2. DEFINITIONS

7:9A-2.1 Definitions

The following words and terms, when used in this chapter, shall have the following meanings unless the context clearly indicates otherwise:

“A-horizon” means the uppermost mineral horizon in a normal soil profile. The upper part of the A-horizon is characterized by maximum accumulation of finely divided, dark colored organic residues, known as humus, which are intimately mixed with the mineral particles of the soil.

"Administrative authority" means the board of health having jurisdiction or its authorized agent acting on its behalf.

"Alteration" means any change in the physical configuration of an existing individual subsurface sewage disposal system or any of its component parts, including replacement, modification, addition or removal of system components such that there will be a change in the location, design, construction, installation, size, capacity, type or number of one or more components. The term "alter" shall be construed accordingly.

"Applicant" means the person who signs and submits an application to construct, install or alter an individual subsurface sewage disposal system.

"Approved" means accepted or acceptable under applicable specifications stated or cited in this chapter, or accepted as suitable for the proposed use under the procedures of this chapter. The word "approval" shall be construed accordingly.

"Approved engineering design" means the engineering plans and specifications for construction, installation or alteration of the individual subsurface sewage disposal system which have been reviewed and approved by the administrative authority.

"Artesian zone of saturation" means a zone of saturation which exists immediately below a hydraulically restrictive horizon, and which has an upper surface which is at a pressure greater than atmospheric, either seasonally or throughout the year.

"Authorized agent" means a licensed health officer, licensed professional engineer or first-grade sanitarian who is delegated to function within specified limits as the agent of the administrative authority.

"Bedrock" means any solid body of rock, with or without fractures, which is not underlain by soil or unconsolidated rock material.

"Bedroom" means any room within a dwelling unit, finished or unfinished, which may reasonably be expected to serve primarily as a bedroom or dormitory. The term bedroom shall be considered to include any room or rooms within an expansion attic.

"Blackwater" means any sanitary sewage generated within a residential, commercial or institutional facility which includes discharges from water closets, toilets, urinals or similar fixtures alone or in combination with other wastewater. Blackwater generally does not include laundry or kitchen wastewater.

"Building sewer" means the pipe extending from the outer wall of the building, or as defined in the State Uniform Construction Code, N.J.A.C. 5:23, to the septic tank or approved place of disposal other than a public sewer.

"Certificate of compliance" means a formal determination in writing by the administrative authority or its authorized agent that an individual subsurface sewage disposal system has been constructed, installed or altered in conformance with the requirements set forth in this chapter as well as any other applicable local ordinances.

"Cesspool" means a covered pit with open-jointed lining into which untreated sewage is discharged, the liquid portion of which is disposed of by leaching into the surrounding soil, the solids or sludge being retained within the pit.

"Chroma" means the relative purity or strength of a color, a quantity which decreases with increasing grayness. Chroma is one of the three variables of soil color as defined in the Munsell system of classification.

"Clay" means a particle size category consisting of mineral particles which are smaller than 0.002 millimeters in equivalent spherical diameter. Also, a soil textural class having more than 40 percent clay, less than 45 percent sand, and less than 40 percent silt, as shown in Figure 3 of Appendix A.

"Clay loam" means a soil textural class having 27 to 40 percent clay and 20 to 45 percent sand, as shown in Figure 3 of Appendix A.

"Commercial unit" means one or more buildings, or one or more rooms within a building, which will be occupied by a single individual, corporation, company, association, society, firm, partnership or joint stock company, and used for non-residential purposes. Within a commercial building, each room or suite of rooms having its own separate sanitary facilities as well as a separate entrance to the outside, or to a hallway, lobby, foyer or other common area, shall be considered to be a separate realty improvement, as defined in this section.

"Coarse fragment" means a rock fragment contained within the soil which is greater than two millimeters in equivalent spherical diameter or which is retained on a two millimeter sieve.

"Construct" means to build, install, fabricate or put together on-site one or more components of an individual subsurface sewage disposal system.

"Conventional disposal field installation" means a type of disposal field installation described in N.J.A.C. 7:9A-10.1(b)1.

“Cobble” means a coarse fragment which is rounded or subrounded in shape and which is between 76 millimeters (three inches) and 254 millimeters (10 inches) in diameter.

“County soil survey report” means a report prepared by the U.S. Department of Agriculture, Soil Conservation Service which includes maps showing the distribution of soil mapping units throughout a particular county together with narrative descriptions of the soil series shown and other information relating to the uses and properties of the various soil series.

“D-box” means a distribution box.

“Delineated stream” or “delineated floodplain” means a stream or flood plain for which the flood hazard areas have been officially specified by the State of New Jersey.

“Department” means the Department of Environmental Protection.

“Design permeability” means the permeability or percolation rate measured at the level of infiltration, as prescribed in N.J.A.C. 7:9A-6. For the purpose of this chapter, a percolation rate measured at the level of infiltration, though not a true measurement of permeability, may be considered to be a form of design permeability.

“Direct supervision” means control over and direction of work carried out by others with full knowledge of and responsibility for such work.

“Disposal bed” means an individual subsurface sewage disposal system component consisting of a closed excavation made within soil or fill material to contain filter material in which two or more distribution laterals have been placed for the disposal of septic tank effluent.

“Disposal field” means a disposal bed or a group of one or more disposal trenches. The perimeter of the disposal field corresponds to the perimeter of the disposal bed, or a line circumscribing the outermost edges of the outermost disposal trenches and including the area between the disposal trenches.

“Disposal trench” means an individual subsurface sewage disposal system component of a covered excavation made within soil or fill material to contain filter material in which a single distribution lateral has been placed for the disposal of septic tank effluent.

“Distribution box” means a water-tight structure which receives sanitary sewage effluent from a septic tank and distributes such sewage effluent in equal portions to two or more pipelines leading to the disposal field.

“Distribution lateral” means a perforated pipe or one of several perforated pipes used to carry and distribute septic tank effluent throughout the disposal field. The term “distribution line” is equivalent in meaning.

“Distribution network” means two or more inter-connected distribution laterals.

“Disturbed ground” means any site or portion of a site which has been modified in its suitability for absorption or disposal of septic tank effluent, or its ability to physically support the system components, as a result of activities carried out by man other than those specified in the approved engineering design. Except for artificial drainage, ground disturbed only for cultivation or related agricultural activities, shall not be considered disturbed ground. Disturbed ground includes those conditions set forth in N.J.A.C. 7:9A-5.10(b).

“Dosing tank” means a water-tight receptacle located between the septic tank and the disposal field, equipped with a siphon or pump, and designed to store and deliver doses of septic tank effluent to the disposal field.

“Dry well” means a covered pit with open-jointed lining through which drainage from roofs, basement floors or areaways may seep into the surrounding soil.

“Dwelling unit” means any building or portion of a building, permanent or temporary in nature, used or proposed to be used as a residence either seasonally or throughout the year.

“Encroachment line” means a line encompassing the channel of a natural stream and portions of the 100-year flood plain adjoining the channel which are reasonably required to carry and discharge the flood water or flood flow of any natural stream. It is approximately equal to the floodway line along delineated streams.

“Equivalent spherical diameter” of a particle means the diameter of a sphere which has a volume equal to the volume of the particle.

“Excessively coarse horizon” means a horizon of limited thickness within the soil profile which provides inadequate treatment of septic tank effluent due to a high coarse fragment content, excessively coarse texture and/or excessively rapid permeability.

“Excessively coarse substratum” means a substratum below the soil profile which extends beyond the depth of soil profile pits and borings and which provides inadequate treatment of septic tank effluent due to a high coarse fragment content, excessively coarse texture and/or excessively rapid permeability.

“Existing ground surface” means the natural surface of the ground at the site of a proposed individual subsurface sewage disposal system after the completion of re-grading in accordance with an approved engineering design.

“Expansion attic” means that part of a dwelling unit left unfinished but which is capable of being finished as a

bedroom or bedrooms and which is accessible by permanent stairways or designed so that stairways can be installed.

“Experimental system” means an individual subsurface sewage disposal system which does not conform in location, design, construction or installation to standard engineering practice as set forth in this chapter.

“Extremely firm consistence” means a type of soil consistence which is described in N.J.A.C. 7:9A-5.3(h).

“Fill material” means any soil, rock or other material which is placed within an excavation or over the pre-existing surface of the ground. The term “fill” is equivalent in meaning.

“Filter material” means washed gravel or crushed stone, free of fines such as dust, ashes or clay, and meeting the size requirements of N.J.A.C. 7:9A-10.3(e)2 or 10.7(f).

“Finished grade” means the surface of the ground after completion of final grading.

“Firm consistence” means a type of soil consistence which is described in N.J.A.C. 7:9A-5.3(h).

“Flood fringe” means that portion of the flood hazard area not designated as the floodway. See N.J.A.C. 7:13.

“Flood hazard area” means the floodway and the flood fringe area of a delineated stream. See also N.J.A.C. 7:13.

“Floodway” means the channel of a natural stream and portions of the flood hazard area adjoining the channel which are reasonably required to carry and discharge the flood water or flood flow of any natural stream. See also N.J.A.C. 7:13.

“Footing drain” means a subsurface drain installed below the foundation of a building to prevent the accumulation of surface and ground water below the foundation of the building.

“Fractured rock substratum” means a rock substratum which contains an adequate number of open and interconnected fractures to allow unimpeded absorption of applied wastewater and transmission of this wastewater away from the disposal area.

“Gal/day” or “gpd” means U.S. gallons per day, which is a measure of rate of flow or hydraulic loading.

“Gravel” means a rounded or subrounded coarse fragment which is between two millimeters (0.1 inches) and 76 millimeters (three inches) in diameter.

“Gravity dosing” means a type of effluent distribution which is defined in N.J.A.C. 7:9A-9.1(a)2.

“Gravity flow” means a type of effluent distribution which is defined in N.J.A.C. 7:9A-9.1(a)1.

“Grease trap” means a device in which the grease present in sanitary sewage is intercepted, congealed by cooling, accumulated and stored for pump-out and disposal.

“Greywater” means that portion of the sanitary sewage generated within a residential, commercial or institutional facility which does not include discharges from water closets or urinals.

“Ground water” means water below the land surface in a zone of saturation.

“Hard consistence” means a type of soil consistence which is described in N.J.A.C. 7:9A-5.3(h).

“Health Officer” means an individual licensed as such pursuant to N.J.S.A. 26:1A-41.

“Holding tank” means a closed water-tight structure designed and operated in such a manner as to receive and store sanitary sewage or septic tank effluent but not to discharge sanitary sewage or septic tank effluent to the surface or ground water or onto the surface of the land.

“Hue” means the dominant spectral color, one of the three variables of soil color defined within the Munsell system of classification.

“Hydraulically restrictive horizon” means a horizon within the soil profile which slows or prevents the downward or lateral movement of water and which is underlain by permeable soil horizons or substrata. Any soil horizon which has a saturated permeability less than 0.2 inch per hour or a percolation rate slower than 60 minutes per inch is hydraulically restrictive.

“Hydraulically restrictive substratum” means a substratum below the soil profile which slows or prevents the downward or lateral movement of water and which extends beyond the depth of profile pits or borings or to a massive substratum. A substratum which has a saturated permeability less than 0.2 inch per hour or a percolation rate slower than 60 minutes per inch is hydraulically restrictive.

“Individual subsurface sewage disposal system” means a system for disposal of sanitary sewage into the ground which is designed and constructed to treat sanitary sewage in a manner that will retain most of the settleable solids in a septic tank and to discharge the liquid effluent to a disposal field. The term “system” is equivalent in meaning.

“Industrial wastes” means solid or liquid wastes resulting from processes employed in industrial establishments or in any commercial establishment engaged in processes which use or generate any of the pollutants or any substance containing any of the pollutants regulated under section 307(a), (b), or (c) of the Federal Clean Water Act of 1977, 33 U.S.C. §§ 1251 et seq., and the regulations promulgated pursuant thereto and any amendments thereto.

“Infiltrative surface” means the interface or contact between the filter material and the soil or fill at the bottom and sidewalls of the disposal bed or each individual disposal trench.

“Install” means to assemble, put in place or connect components of an individual subsurface sewage disposal system in a manner that will permit their use by the occupants of the realty improvement served.

“Interceptor drain” means a subsurface drain designed and constructed to intercept laterally moving perched ground water.

“Invert” means the floor, bottom or lowest portion of the internal cross-section of a closed conduit, used with reference to pipes or fittings conveying sanitary sewage.

“Level of infiltration” means the elevation of the horizontal interface or contact between the filter material and the soil or fill material at the bottom of the filter material.

“Limiting zone” means any horizon or combination of horizons within the soil profile, or any substratum or combination of substrata below the soil profile, which limits the ability of the soil to provide treatment and/or disposal of septic tank effluent. Limiting zones include rock substrata, hydraulically restrictive horizons and substrata, excessively coarse horizons and substrata, perched and regional zones of saturation. Criteria for recognition of limiting zones are given in N.J.A.C. 7:9A-5.5 through 5.9.

“Loamy sand” means a soil textural class, as shown in Figure 3 of Appendix A, that has a maximum of 85 to 90 percent sand with a percentage of silt plus 1.5 times the percentage of clay not in excess of 15; or a minimum of 70 to 85 percent sand with a percentage of silt plus 1.5 times the percentage of clay not in excess of 30.

“Lower plastic limit” means the moisture content corresponding to the transition between the plastic and semi-solid states of soil consistency. This corresponds to the lowest soil moisture content at which the soil can be molded in the fingers to form a rod or wire, one-eighth of an inch in thickness, without crumbling.

“Malfunctioning system” means an individual sewage disposal system which pollutes ground or surface waters or which creates a nuisance or hazard to public health or safety or the environment and includes, but is not limited to, the situations described in N.J.A.C. 7:9A-3.4.

“Massive rock substratum” means a rock substratum which does not contain an adequate number of open and inter-connected fractures to allow unimpeded absorption of applied wastewater and transmission of this wastewater away from the disposal area.

“Massive structure” means one of the soil structural classes which is described in N.J.A.C. 7:9A-5.3(h).

“Mottling” means a color pattern observed in soil consisting of blotches or spots of contrasting color. The term “mottle” refers to an individual blotch or spot. Mottling is an indication of seasonal or periodic and recurrent saturation.

“Mounded disposal field installation” means a type of disposal field installation which is described at N.J.A.C. 7:9A-10.1(b)4.

“Mounded soil replacement disposal field installation” means a type of disposal field installation which is described at N.J.A.C. 7:9A-10.1(b)5.

“Munsell system” means a system of classifying soil color consisting of an alpha-numeric designation for hue, value and chroma, such as “7.5 YR 6/2”, together with a descriptive color name, such as “strong brown”.

“NJPDES permit” means a permit issued by the Department pursuant to the authority of the Water Pollution Control Act, N.J.S.A. 58:10A-1 et seq., and N.J.A.C. 7:14A for a discharge of pollutants.

“NJPDES” means the New Jersey Pollutant Discharge Elimination System as set forth in N.J.S.A. 58:10A-1 et seq. and in N.J.A.C. 7:14A.

“O-horizon” means a surface horizon, occurring above the A-horizon in some soils, which is composed primarily of undecomposed or partially decomposed plant remains which have not been incorporated into the mineral soil.

“One hundred year flood plain” means the area inundated by the 100-year flood. A 100-year flood is estimated to have a one percent chance, or one chance in 100, of being equalled or exceeded in any one year. See also N.J.A.C. 7:13.

“Operate” means to use or convey a building or facility served by an individual subsurface sewage disposal system or to own a building or facility where such use or occupation exists.

“Perched zone of saturation” means a zone of saturation which occurs immediately above a hydraulically restrictive horizon and which is underlain by permeable horizons or substrata which are not permanently or seasonally saturated.

“Percolation rate” means the rate of fall of water measured in a test hole as prescribed in N.J.A.C. 7:9A-6.4

“Permeability” means the rate at which water moves through a unit area of soil or rock material at hydraulic gradient of one, determined as prescribed in N.J.A.C. 7:9A-6.2, 6.3, 6.5 or 6.6.

“Permeable” means having a permeability of 0.2 inches per hour or faster or a percolation rate of 60 minutes per

inch or faster. The terms "permeable soil", "permeable rock" and "permeable fill" shall be construed accordingly.

"Permit" means a written approval issued by the administrative authority or the Department for the construction, installation, alteration or operation of an individual subsurface sewage disposal system.

"Person" means an individual, corporation, company, association, society, firm, partnership and joint stock company as well as the State and any political subdivision thereof.

"Piezometer" means a device consisting of a length of metal or plastic pipe, open at the bottom or perforated within a specified interval, and used for the determination of depth to water, permeability or hydraulic head within a specific soil horizon or substratum.

"Platy structure" means one of the soil structural classes described in N.J.A.C. 7:9A-5.3(g).

"Practice of engineering" means any professional service or creative work requiring engineering education, training, and experience and the application of special knowledge of the mathematical, physical and engineering sciences to such professional services or creative work as consultation, investigation, evaluation, planning, design or general supervision of construction or operation for the purpose of assuring compliance with plans, specification and design in connection with any public or private engineering or industrial project.

"Pre-existing natural ground surface" means the former level of the ground surface in an area of disturbed ground prior to the disturbance.

"Pressure dosing" means a type of effluent distribution which is described in N.J.A.C. 7:9A-9.1.

"Pre-treatment unit" means a septic tank or a grease trap.

"Professional engineer" means a person licensed to practice professional engineering in this State pursuant to N.J.S.A. 48:8-27 et seq.

"Realty improvement" means any proposed new residence, commercial building or other premises (including, but not limited to, condominiums, garden apartments, town houses, mobile homes, stores, office buildings, restaurants, hotels and so forth) not served by an approved water supply and approved sewerage system, the useful occupancy of which will require the installation or erection of a water supply system or sewerage facilities. Each dwelling unit in a proposed multiple-family dwelling or each commercial unit in a commercial building shall be construed to be a separate realty improvement.

"Regional zone of saturation" means a zone of saturation which extends vertically without interruption below the depth of soil borings and profile pits.

"Re-grading" means modification of a land slope by cutting and filling with the native soil or re-distribution of the native soil which is present at the site.

"Repair" means to fix, refurbish or replace one or more components of an individual subsurface sewage disposal system in a manner that will restore, preserve and not change the original location, design, construction and installation, size, capacity, type, or number of the components of the system.

"Replicate" means one of two or more soil samples or tests taken at the same location (within five feet of each other), and depth, within the same soil horizon or substratum. In the case of fill material, replicate tests are tests performed on sub-samples of the same bulk sample packed to the same bulk density.

"Reservoir" means a surface water body used to store a public drinking water supply or any portion of a tributary water course within one mile upstream of such a surface water body.

"Restricted chemical material" means any chemical material which contains concentrations in excess of one part per hundred, by weight of any halogenated hydrocarbon chemical, aliphatic or aromatic, including, but not limited to, trichloroethane, trichloroethylene, tetrachloroethylene, methylene chloride, halogenated benzenes and carbon tetrachloride; any aromatic hydrocarbon chemical, including, but not limited to, benzene, toluene and naphthalene; any phenol derivative in which a hydroxy group and two or more halogen atoms are bonded directly to a six-carbon aromatic ring, including, but not limited to, trichlorophenol or pentachlorophenol; or acrolein, acrylonitrile, or benzidine. Restricted chemical material does not, however, include any chemical material which is biodegradable and not a significant source of contamination of the ground waters of the State.

"Rock substratum" means a solid and continuous body of rock, with or without fractures, or a weathered or broken body of rock fragments overlying a solid body of rock, where more than 50 percent by volume of the rock fragments are greater than two millimeters in diameter or large enough to be retained on a two millimeter sieve.

"Sand" means a particle size category consisting of mineral particles which are between 0.05 and 2.0 millimeters in equivalent spherical diameter. Also, a soil textural class having 85 percent or more of sand and a content of silt and clay such that the percentage of silt plus 1.5 times the percentage of clay does not exceed 15, as shown in Figure 3 of Appendix A.

"Sandy clay" means a soil textural class having 35 percent or more of clay and 45 percent or more of sand, as shown in Figure 3 of Appendix A.

“Sanitarian First Grade” means an individual licensed as such pursuant to N.J.S.A. 26:1A-41.

“Sanitary sewage” means any liquid waste containing animal or vegetable matter in suspension or solution, or the water carried wastes resulting from the discharge of water closets, laundry tubs, washing machines, sinks, dishwashers, or any other source of water carried wastes of human origin or containing putrescible material. This term specifically excludes industrial, hazardous or toxic wastes and materials.

“Scum” means a mass of sewage solids floating at the surface of sewage and buoyed up by entrained gas, grease, or other substances. The term “scum layer” shall be construed accordingly.

“Seasonally high water table” means the upper limit of the shallowest zone of saturation which occurs in the soil, identified as prescribed in N.J.A.C. 7:9A-5.8.

“Seepage pit” means a covered pit with open-jointed lining through which septic tank effluent may seep into the surrounding soil.

“Septic tank” means a water-tight receptacle which receives the discharge of sanitary sewage from a building sewer or part thereof, and is designed and constructed so as to permit settling of settleable solids from the liquid, partial digestion of the organic matter, and discharge of the liquid portion into a disposal field or seepage pit.

“Septic tank effluent” means the primary treated wastewater or sewage discharged through the outlet of a septic tank. The term “effluent” is equivalent in meaning.

“Serial distribution” means a method of distributing septic tank effluent between a series of disposal trenches so that each successive trench receives effluent only after the preceding trenches have become full to overflowing.

“Sewage system cleaner” means any solid or liquid material intended or used primarily for the purpose of cleaning, treating, degreasing, unclogging, disinfecting or deodorizing any part of a sewage system but excluding those liquid or solid products intended or used primarily for manual cleaning, scouring, treating, deodorizing or disinfecting the surface of common plumbing fixtures.

“Sewage system” means any part of a wastewater disposal system, including but not limited to all toilets, piping, drains, sewers, septic tanks, grease traps, distribution boxes, dosing tanks, disposal tanks, disposal fields, seepage pits, cesspools or dry wells.

“Silt” means a particle size category consisting of mineral particles which are between 0.002 and 0.05 millimeters in equivalent spherical diameter. It also means a soil textural class having 80 percent or more of silt and 12 percent or less of clay, as shown in Figure 3 of Appendix A.

“Silty clay” means a soil textural class having 40 percent or more of clay and 40 percent or more of silt, as shown in Figure 3 of Appendix A.

“Silty clay loam” means a soil textural class having 27 to 40 percent of clay and less than 20 percent of sand, as shown in Figure 3 of Appendix A.

“Silt loam” means a soil textural class having 50 percent or more of silt and 12 to 27 percent of clay; or 50 to 80 percent of silt and less than 12 percent of clay, as shown in Figure 3 of Appendix A.

“Single grain structure” means one of the soil structural classes which are described in N.J.A.C. 7:9A-5.3(h).

“Sink hole” means a topographic depression the origin of which may be attributed to the dissolution and collapse of underlying limestone or dolomite bedrock.

“Sludge” means a relatively dense suspension of sewage solids which settle to the bottom of a septic tank, are relatively resistant to biological decomposition, and which collect in the septic tank over a period of time. The term “sludge layer” shall be construed accordingly.

“Soil” means any naturally occurring unconsolidated body of mineral and organic particles derived from the weathering in place of consolidated rock or unconsolidated mineral deposits and the decay of living organisms.

“Soil aggregate” means a naturally occurring unit of soil structure consisting of particles of sand, silt, clay, organic matter, and coarse fragments held together by the natural cohesion of the soil.

“Soil color” means the soil color name and Munsell color designation determined by comparison of the moist soil with color chips contained in a Munsell soil color book.

“Soil consistence” means the resistance of a soil aggregate or clod to being crushed between the fingers or broken by the hands. Terms for describing soil consistence described are in N.J.A.C. 7:9A-5.3(h).

“Soil horizon” means a layer within a soil profile differing from layers of soil above and below it in one or more of the soil morphological characteristics including color, texture, coarse fragment content, structure, consistence and mottling.

“Soil log” means a description of the soil profile which includes the depth, thickness, color, texture, coarse fragment content, mottling, structure and consistence of each soil horizon or substratum.

“Soil mapping unit” means an area outlined on a map in a County Soil Survey Report and marked with a letter symbol designating a soil phase, a complex of two or more

soil phases, or some other descriptive term where no soil type has been identified.

“Soil material” means soil as well as any naturally occurring unconsolidated mineral deposit which is not a rock substratum.

“Soil phase” means a specific type of soil which is mapped by the Soil Conservation Service and which belongs to a soil series described within the County Soil Survey Report.

“Soil profile” means a vertical cross-section of undisturbed soil showing the characteristic horizontal layers or horizons of the soil which have formed as a result of the combined effects of parent material, topography, climate, biological activity and time.

“Soil profile pit” means an excavation made for the purpose of exposing a soil profile which is to be described.

“Soil replacement disposal field installation” means a disposal field installed as prescribed in N.J.A.C. 7:9A-10.1(b)2 and 3.

“Soil series” means a grouping of soil types possessing a specific range of soil profile characteristics which are described within the County Soil Survey Report. Each soil series may consist of several “soil phases” which may differ in slope, texture of the surface horizon or stoniness.

“Soil structural class” means one of the shape classes of soil structure described in N.J.A.C. 7:9A-5.3(g).

“Soil structure” means the naturally occurring arrangement, within a soil horizon, of sand, silt and clay particles, coarse fragments and organic matter, which are held together in clusters or aggregates of similar shape and size.

“Soil texture” means the relative proportions of sand, silt and clay in that portion of the soil which passes through a sieve with two millimeter openings.

“Soil textural class” means one of the classes of soil texture defined within the USDA system of classification. (Soil Survey Manual, Agricultural Handbook No. 18, U.S.D.A. Soil Conservation Service 1962.)

“Soil suitability class” means one of the classes of soil suitability with regard to the installation of an individual subsurface sewage disposal system which are defined based upon the type and depth of limiting zones present, as prescribed in N.J.A.C. 7:9A-5.4.

“Special ordinance” means an ordinance which sets requirements for the location, design, construction, alteration or use of individual subsurface sewage disposal systems which differ from the requirements of this chapter.

“Static water level” means the depth below the ground surface or the elevation with respect to some reference level, of the water level observed within a soil profile pit or boring, or within a piezometer, after this level has stabilized or become relatively constant with the passage of time.

“Stone” means a coarse fragment which is rounded or subrounded in shape and greater than 254 millimeters (10 inches) in diameter.

“Subsurface drain” means any open pipe, layer of gravel, stone or coarse sand, or any combination of these elements placed below the surface of the ground and designed or constructed in such a manner as to allow movement of ground water into any surface water body, water course or onto the surface of the ground.

“Substratum” means a layer of soil or rock material present below the soil profile and extending beyond the depth of soil borings or profile pits.

“Suitable soil” means unsaturated soil, above the seasonally high water table, which contains less than 50 percent by volume of coarse fragments and which has a permeability between 0.2 and 20 inches per hour or a percolation rate between three and 60 minutes per inch.

“Suitable fill” means fill material which meets the requirements of N.J.A.C. 7:9A-10.1(f).

“Surface water” means any waters of the State which are not ground water.

“System” is an abbreviated designation for “individual subsurface sewage disposal system” and is equivalent in meaning.

“Test replicate” means one of two or more soil tests performed using the same procedure on each of several soil samples taken within the same soil horizon and at the same location within the proposed disposal field. The term “replicate sample” shall be construed accordingly.

“Textural analysis” means the determination of soil texture by means of a hydrometer analysis and a sieve analysis.

“Treatment works approval” means a permit issued by the Department pursuant to N.J.A.C. 7:14A-12.3 for a subsurface sewage disposal system which is beyond the scope or not in strict conformance with the requirements of this chapter.

“Undisturbed soil sample” means a soil sample in which the natural soil structure, porosity and cohesion are preserved intact, and in which the only cracks or planes of separation evident are those occurring naturally between soil aggregates.

“Value” means the relative lightness or intensity of a color, one of the three variables of soil color defined within the Munsell system of classification.

“Very firm consistence” means a type of soil consistence which is described in N.J.A.C. 7:9A-5.3(h).

“Very hard consistence” means a type of soil consistence which is described in N.J.A.C. 7:9A-5.3(h).

“Volume of sanitary sewage” means the maximum volume of sanitary sewage which may reasonably be expected to be discharged from a residential, commercial or institutional facility on any day of operation, determined as prescribed in N.J.A.C. 7:9A-7.4 and expressed in gallons per day. The volume of sanitary sewage shall not be considered as an average daily flow, but shall incorporate a factor of safety over and above the average daily flow which is adequate to accommodate peak sewage flows or facilities which discharge greater than the average volumes of sanitary sewage either occasionally or on a regular basis. The use of water saving devices shall not be used as a basis for reducing estimates of the volume of sanitary sewage.

“Water course” means any stream or surface water body, or any ditch or subsurface drain that will permit drainage into a surface water body. This term does not include swales or roadside ditches which convey only direct runoff from storms or snow melting, and storm sewers designed and constructed in a manner that will prevent infiltration of ground water into the pipe or lateral movement of ground water through the excavation in which the pipe has been laid.

“Waters of the State” means the ocean and its estuaries, all springs, streams and bodies of surface and ground water, whether natural or artificial, within the boundaries of this State or subject to its jurisdiction.

“Water table” means the upper surface of a zone of saturation.

“Well” means a bored, drilled or driven shaft, or a dug hole, which extends below the seasonally high water table and which has a depth which is greater than its largest surface dimension.

“Wetland” means any area inundated or saturated by surface or ground water at a frequency or duration sufficient to support, and which under normal circumstances does support, a prevalence of vegetation typically adapted for life in saturated soil conditions, commonly known as hydrophytic vegetation. Wetlands generally include swamps, marshes, bogs and similar areas.

“U.S.D.A. system of classification” means the system of classifying soil texture used by the United States Department of Agriculture which defines 12 soil textural classes based upon the weight percentages of sand, silt and clay in

that portion of the soil which passes through a sieve with two millimeter openings. The soil textural classes are shown graphically on the soil textural triangle, Figure 3 of Appendix A.

“Zone of disposal” means the permeable layers of soil or rock material below the zone of treatment which permit downward movement of the septic tank effluent and lateral movement of this effluent away from the area of the disposal field.

“Zone of treatment” means the upper four feet of suitable soil or fill material, below the level of infiltration, which remove pollutants from the septic tank effluent by processes which include physical filtration of bacteria, adsorption of viruses and bacteria by clay and organic matter, biological destruction of pathogens by soil microorganisms, chemical fixation or precipitation of phosphorous, bio-chemical transformations of nitrogen compounds and biological assimilation of phosphorous and nitrogen.

“Zone of saturation” means a layer within or below the soil profile which is saturated with ground water either seasonally or throughout the year.

Amended by R.1993 d.294, effective June 21, 1993.

See: 24 N.J.R. 1987(a), 25 N.J.R. 2704(b).

Amended by R.1994 d.469, effective September 19, 1994.

See: 26 N.J.R. 2715(a), 26 N.J.R. 3829(a).

SUBCHAPTER 3. ADMINISTRATION

7:9A-3.1 Ordinances

(a) The administrative authority may adopt this chapter by reference as allowed by N.J.S.A. 26:3-69 to 69.6.

(b) For the purpose of this chapter, the term “special ordinance” means any ordinance which differs in any detail from this chapter. Within 10 days after adoption of a special ordinance, the administrative authority shall forward to the Department a copy of the ordinance together with a written statement in which all provisions which differ from this chapter are identified, the reasons for the differences are explained and all supporting facts and data are provided. Where requirements differing from the requirements of this chapter are proposed in order to conform with the requirements of the Pinelands Comprehensive Management Plan, the appropriate section(s) of the Plan shall be cited.

(c) The administrative authority shall not adopt an ordinance which is less stringent than this chapter.

7:9A-3.2 New system design approvals

(a) All aspects of the location, design, construction, installation, operation, alteration and repair of individual sub-

surface sewage disposal systems approved after January 1, 1990 shall comply with the requirements of these standards.

(b) Designs for individual subsurface sewage disposal systems approved by the administrative authority prior to January 1, 1990 may be installed and certified pursuant to the rules in effect at the time of the approval. Such approvals may be valid for up to five years following January 1, 1990 provided that the following conditions are met:

1. That any modifications to the approved engineering design plans involving location, design, construction and installation of components specific to the individual subsurface sewage disposal system are limited to those which are necessary to address specific soil or site limitations encountered during construction but not previously identified in the approved engineering design plans; and

2. That the period for which such approvals are valid is not limited by any ordinances adopted by the administrative authority.

Amended by R.1992 d.187, effective April 20, 1992.

See: 24 N.J.R. 202(a), 24 N.J.R. 1491(a).

Outlined the circumstances under which septic system designs which the board of health having jurisdiction or its authorized agent (administrative authority) approved before January 1, 1990, in accordance with the rules which were repealed July 28, may be constructed, installed and certified.

7:9A-3.3 Existing systems

(a) The use of systems in existence prior to the effective date of this chapter may be continued without change provided that these systems were located, designed, constructed and installed in conformance with the standards in effect at the time when they were installed and provided that such systems are not malfunctioning.

(b) When an expansion or a change in use of a commercial building or facility served by an existing individual subsurface sewage disposal system is proposed and such expansion or change will result in an increase in the volume of sanitary sewage (determined as prescribed at N.J.A.C. 7:9A-7.4) or a change in the type of wastes discharged (see N.J.A.C. 7:9A-7.3), the administrative authority shall not approve such an expansion or change unless all of the following conditions are satisfied:

1. All aspects of the location, design, construction, installation and operation of the existing system are in conformance with the requirements of this chapter or are altered so that they will be in conformance with the requirements of this chapter;

2. The expansion or change of use of the building or facility served will not exceed the design capacity of the existing system; and

3. It is demonstrated to the satisfaction of the administrative authority that the existing system is not malfunctioning.

(c) When an expansion or a change in use of a residential dwelling served by an existing individual subsurface sewage disposal system is proposed and such an expansion or change will exceed 100 square feet of habitable living space (as defined in the New Jersey Uniform Construction Code, N.J.A.C. 5:23) and such expansion or change will result in an increase in the volume of sanitary sewage (determined as prescribed at N.J.A.C. 7:9A-7.4) or will result in a change in the type of wastes discharged (see N.J.A.C. 7:9A-7.3), the administrative authority shall not approve such an expansion or change unless all of the following conditions are satisfied:

1. All aspects of the location, design, construction, installation and operation of the existing system are in conformance with the requirements of this chapter or are altered so that they will be in conformance with the requirements of this chapter;

2. The expansion or change of use of the dwelling served does not increase the design flow of the dwelling beyond the design capacity of the existing system; and

3. It is demonstrated to the satisfaction of the administrative authority that the existing system is not malfunctioning.

(d) Alterations made to a system for reasons other than a change of use or expansion as described in (b) and (c) above may be approved by the administrative authority provided that both of the following conditions are met:

1. If the scope of the alteration is such that it constitutes the practice of professional engineering according to N.J.S.A. 45:8 and the rules adopted pursuant to same, then such alterations shall be made in conformance with plans and specifications signed and sealed by a licensed professional engineer; and

2. Alterations are made in such a way that those components of the system altered are in conformance with the requirements of this chapter or are closer to being in conformance with this chapter than the original components prior to the alteration.

(e) When alterations are made to correct a malfunctioning system, the alterations shall be made in conformance with (d) above and in a manner that will eliminate the cause of the malfunction and which, with proper operation and maintenance, will not result in future malfunctions.

(f) Alterations to an existing malfunctioning community onsite subsurface disposal system, as defined in N.J.A.C. 7:14A-1.9, may be approved by the administrative authority pursuant to the provisions of this chapter upon written authorization of such by the Department.

(g) Repairs may be made in the same manner as in the original system, with the exception of cesspools which shall be corrected as prescribed at N.J.A.C. 7:9A-1.6(g), provided that all repairs are approved by the administrative authority.

(h) A person who discharges industrial wastes by means of an existing subsurface sewage disposal system and who has not already applied to the Department for a NJPDES permit shall apply immediately.

(i) A person who discharges sanitary wastes by means of an existing community onsite subsurface disposal system, as defined in N.J.A.C. 7:14A-1.9, who did not apply to the Department for a NJPDES permit by August 21, 1991 is in violation of the Water Pollution Control Act, and shall apply for such a permit immediately.

Amended by R.1993 d.294, effective June 21, 1993.

See: 24 N.J.R. 1987(a), 25 N.J.R. 2704(b).

Amended by R.1994 d.469, effective September 19, 1994.

See: 26 N.J.R. 2715(a), 26 N.J.R. 3829(a).

7:9A-3.4 Malfunctioning systems

(a) Indications that an individual subsurface sewage disposal system is malfunctioning include but are not limited to the following:

1. Contamination of nearby wells or surface water bodies by sewage or effluent as indicated by the presence of fecal bacteria where the ratio of fecal coliform to fecal streptococci is four or greater;
2. Ponding or breakout of sewage or effluent onto the surface of the ground;
3. Seepage of sewage or effluent into portions of buildings below ground; or
4. Back-up of sewage into the building served which is not caused by a physical blockage of the internal plumbing.

(b) When an individual subsurface sewage disposal system has been determined to be malfunctioning, the owner shall take immediate steps to correct the malfunction. When it becomes necessary to repair or replace one or more system components or to make alterations to the system, all of the following requirements shall be met:

1. The owner or owner's agent shall notify the administrative authority or its authorized agent immediately upon detection of a malfunctioning system. The owner shall obtain prior approval from the administrative authority or its authorized agent for any repairs or alterations made.
2. Alterations made to correct a malfunctioning system shall meet the requirements of N.J.A.C. 7:9A-3.3(c). In cases where the alteration does not involve the practice of engineering as defined by N.J.S.A. 45:8-28(b), the administrative authority or its authorized agent may approve plans and specifications prepared by a septic system installer rather than a licensed professional engineer.
3. When the malfunction involves continuous discharge of sewage or septic tank effluent onto the surface of the ground or into a watercourse, the use of the system

shall cease until repairs or alterations have been completed in a manner which is satisfactory to the administrative authority. In such cases, the administrative authority may permit continued occupation of the building served provided that further surface discharge of sewage or septic tank effluent is prevented by installation of a holding tank or use of an existing septic system component as a holding tank. The latter may be accomplished by pumping-out the septic tank, dosing tank, seepage pit or other system component at an adequate frequency to prevent overflow.

(c) The administrative authority may, under certain circumstances, approve as a last resort, the permanent use of a holding tank to correct the problem of a malfunctioning system which cannot be repaired or altered in a satisfactory manner. Such approval may be granted by the administrative authority only if prior written approval has been granted by the Department and one of the following criteria is met:

1. The malfunctioning system serves a single family dwelling or other facility falling within the limitations set forth in N.J.A.C. 7:9A-1.8 and the system was constructed prior to the effective date of this chapter; or
2. The malfunctioning system serves a facility which exceeds the limitations set forth in N.J.A.C. 7:9A-1.8 but was constructed prior to March 6, 1981, the effective date of the NJPDES rules (N.J.A.C. 7:14A).

(d) The Department and the administrative authority may approve the permanent use of a holding tank to correct the problem of a malfunctioning system only when all of the following facts have been established to the satisfaction of the administrative authority and the Department:

1. The present malfunctioning system poses a threat or a potential threat to ground or surface water quality or public health or safety or the environment;
2. Due to site conditions, lot configuration, financial circumstances or other constraints, repair, or alteration of the system in a manner that will eliminate the cause of the malfunction is not feasible;
3. Public sewers are by practical means not available;
4. Reduction of disposal field hydraulic loading by means of water-saving plumbing fixtures will not correct the malfunction; and
5. Assurances are given that the holding tank will be emptied and the contents disposed of in a manner which complies with all applicable local, State and Federal ordinances, statutes and regulations. As a means of confirmation, the owner of the system shall install a water meter and shall submit to the administrative authority on a quarterly basis, evidence of dates and quantities of sewage removed, name of person(s) or firm(s) contracted to remove the sewage, the name of the facility(s) to which the sewage is taken, as well as any other evidence or information which is requested by the administrative authority.

Amended by R.1993 d.294, effective June 21, 1993.
See: 24 N.J.R. 1987(a), 25 N.J.R. 2704(b).

7:9A-3.5 Permit to construct or alter

(a) A person shall not construct, install or alter an individual subsurface sewage disposal system until the administrative authority or its authorized agent has issued a permit for such construction, installation or alteration.

(b) The administrative authority or its authorized agent shall not issue a permit to construct, install or alter an individual subsurface sewage disposal system until an application has been submitted as prescribed in (c) below and, based upon a review of the application submitted, the location and design of the proposed system are found by the administrative authority or its authorized agent to be in conformance with the requirements of this chapter.

(c) The applicant shall submit a complete, accurate and properly executed application to the administrative authority. All soil logs, soil testing data, design data and calculations, plans and specifications, and other information submitted in connection with the subsurface sewage disposal system design shall be signed and sealed by a licensed professional engineer except where N.J.A.C. 7:9A-3.3(d)1 allows otherwise. The application shall include the following information:

1. Key maps showing the approximate boundaries of the lot on a U.S. Geological Survey (U.S.G.S.) topographic quadrangle or other accurate map and on a U.S.D.A. soil survey map, which is available from the Soil Conservation Service ("SCS"). A good quality photo-copy reproduction of the U.S.G.S. quadrangle or U.S.D.A. soil survey map may be used for this purpose. The requirement for a soil survey map does not apply to Essex or Hudson counties, where no modern soil survey is currently available;

2. A site plan, prepared in accordance with N.J.A.C. 13:40-7 and drawn at a scale adequate to depict clearly the following features within a 150 foot radius around the proposed system:

i. Location of all components of the proposed system including, but not limited to, septic tanks, grease traps, dosing tanks, distribution boxes, distribution laterals, disposal fields, interceptor drains and seepage pits;

ii. Boundaries of lot;

iii. Locations of existing and proposed buildings, roadways, subsurface drains, wells and disposal areas on same lot and on adjacent lots;

iv. Existing and finished grade topography (two foot contour interval) using absolute elevations or relative elevations referenced to a permanent bench-mark;

v. Location of all surface water bodies, natural and artificial, and all springs or areas of ground water seepage;

vi. Location of existing and proposed surface water diversions;

vii. Location of all outcrops of bedrock;

viii. Conformance with setback requirements as required in N.J.A.C. 7:9A-4.3;

ix. Location of all soil profile pits, soil borings and permeability tests;

x. Location of stream encroachment boundaries for streams within the near vicinity of the site; and

xi. State approved boundaries of any wetland areas or transition areas within the boundaries of the property or within 150 feet of the area of the proposed system. Alternatively, the applicant may submit evidence of compliance with the requirements of N.J.A.C. 7:7A as provided pursuant to N.J.A.C. 7:9A-4.7(b) or (c).

3. Soil logs prepared as prescribed in N.J.A.C. 7:9A-5.3;

4. Soil suitability class(es) determined as prescribed in N.J.A.C. 7:9A-5.4;

5. Results of permeability tests performed as prescribed in N.J.A.C. 7:9A-6, including all test data and calculations;

6. Maximum expected daily volume of sanitary sewage and method of calculation;

7. Detailed engineering plans and specifications for all components of the systems; and

8. All data and calculations used in the design of the sewage system.

(d) Applications shall be made using standard forms provided in Appendix B of this chapter or forms provided by the administrative authority which contain all of the information required on the standard forms in Appendix B. The administrative authority or its authorized agent may require additional data or the completion by the applicant of additional application forms.

Amended by R.1993 d.294, effective June 21, 1993.

See: 24 N.J.R. 1987(a), 25 N.J.R. 2704(b).

Amended by R.1994 d.469, effective September 19, 1994.

See: 26 N.J.R. 2715(a), 26 N.J.R. 3829(a).

7:9A-3.6 Witnessing of soil evaluation and testing

(a) The administrative authority or its authorized agent shall witness the excavation of soil profile pits and borings, in-situ permeability testing or soil sample collection and any other site evaluation procedure relied upon in the design or location of the system. The administrative authority or its authorized agent may require a maximum of 15 business days prior to written notice for the purpose of witnessing of soil evaluation or testing procedures.

(b) The administrative authority may waive the requirements for witnessing of soil evaluation or testing procedures which are identified in (a) above. Failure of the administrative authority or its authorized agent to be present when 15 business days prior written notice has been given shall be construed to be a waiver of the witnessing requirements.

7:9A-3.7 Modification of plans

(a) Modification of plans or specifications for an individual subsurface sewage disposal system made subsequent to approval of the plans shall not be carried out unless the revisions are in conformance with the requirements of this chapter and noted on a revised set of plans which have been signed, sealed and dated by a licensed professional engineer and approved by the administrative authority or its authorized agent.

(b) Any modification to plans or specifications made without approval of the administrative authority shall render the original approval null and void and a new application shall be required.

(c) The administrative authority or its authorized agent may require the revision of plans or specifications as it deems necessary if conditions found prior to or during construction warrant such change in order to obtain conformance with the provisions of this chapter.

Amended by R.1993 d.294, effective June 21, 1993.
See: 24 N.J.R. 1987(a), 25 N.J.R. 2704(b).

7:9A-3.8 Pinelands area approvals

The administrative authority shall not approve an application to construct, install or alter an individual subsurface sewage disposal system within the Pinelands area (as defined in N.J.S.A. 13:18A-1 et seq.) until the Pinelands Commission has issued a Notice of Filing, Certificate of Compliance, Certificate of Filing, development approval, or a written statement that no approval from the Pinelands Commission is required. All approvals issued by the administrative authority shall be consistent with the requirements of N.J.A.C. 7:50-5 and 6, and shall be reported to the Pinelands Commission in accordance with N.J.A.C. 7:50-4.

7:9A-3.9 Treatment works approval

(a) A treatment works approval issued by the Department is required for any subsurface sewage disposal system other than a system serving a single dwelling unit, building, commercial unit or other realty improvement, located on a single property, generating less than 2000 gpd of sanitary sewage only, which is designed, constructed and operated in conformance with this chapter.

(b) Whenever a proposed subsurface sewage disposal system meets any of the following criteria, the administrative authority shall direct the applicant to apply to the Department for a treatment works approval.

1. The system will exceed any of the limitations set forth in N.J.A.C. 7:9A-1.8;

2. The design or construction of one or more components of the system will not be in conformance with this chapter;

3. The system utilizes unproven technology or is otherwise experimental in nature, so that adequate functioning of the system will depend upon the installation, operation or maintenance of components or treatment processes not provided for in this chapter;

4. The system is designed to provide wastewater treatment in order to meet effluent discharge limitations or ground and surface water quality standards as prescribed by applicable State or Federal regulations or statutes;

5. Sewage will not flow by gravity from the realty improvement served to the septic tank; or

6. The system will serve multiple units in a campground or mobile home park or a portion thereof.

(c) Applications for treatment works approval shall be made on forms available from the Department and shall be accompanied by the required application fee. Application forms and instructions regarding administrative and technical submission requirements may be obtained by contacting the Department at the following address:

Department of Environmental Protection
Division of Water Quality
Bureau of Operational Groundwater Permits
CN-209
Trenton, N.J. 08625

Amended by R.1993 d.294, effective June 21, 1993.
See: 24 N.J.R. 1987(a), 25 N.J.R. 2704(b).
Amended by R.1994 d.469, effective September 19, 1994.
See: 26 N.J.R. 2715(a), 26 N.J.R. 3829(a).

7:9A-3.10 NJPDES permits

(a) Individual subsurface sewage disposal systems which serve single family dwelling units and which are located, designed, constructed, installed, altered, repaired and operated in conformance with the requirements set forth in these standards are exempt from NJPDES permit requirements in accordance with N.J.A.C. 7:14A-5.1(b)2ii. *old site*

(b) Subsurface sewage disposal systems which serve facilities other than single family dwelling units and which are located, designed, constructed, installed, altered, repaired and operated in conformance with the requirements set forth in this chapter, and N.J.S.A. 58:11-43 et seq. where these restrictions are applicable, are authorized by rule.

(c) When the proposed system does not fall into either of the categories outlined in (a) or (b) above, the administrative authority shall direct the applicant to apply to the Department for a NJPDES permit.

Amended by R.1993 d.294, effective June 21, 1993.
See: 24 N.J.R. 1987(a), 25 N.J.R. 2704(b).

7:9A-3.11 Experimental systems

The Department encourages the development and use of new technologies which may improve the treatment of sanitary sewage prior to discharge or allow environmentally safe disposal of sanitary sewage in areas where standard sewage disposal systems might not function adequately. Where the design, location, construction or installation of the system or any of its components does not conform to this chapter, the administrative authority shall direct the applicant to apply to the Department for a treatment works approval. Depending upon the volume and quality of the wastewater discharged, a NJPDES permit may also be required.

7:9A-3.12 Holding tanks

(a) The administrative authority may approve the use of a sewage holding tank in lieu of an individual subsurface sewage disposal system, as a temporary means of waste disposal, for a period not to exceed 180 days, where alteration or repair of an existing system is being implemented as approved by the administrative authority.

(b) The administrative authority may approve permanent use of a holding tank in the case of a malfunctioning system, subject to approval by the Department, as allowed in N.J.A.C. 7:9A-3.4(c).

Amended by R.1993 d.294, effective June 21, 1993.
See: 24 N.J.R. 1987(a), 25 N.J.R. 2704(b).

7:9A-3.13 Certificate of compliance

(a) Prior to issuance of a certificate of compliance, the administrative authority or its authorized agent shall make sufficient inspections during the course of construction and installation or alteration of the individual subsurface sewage disposal system to determine that the system has been located, constructed and installed or altered in compliance with the requirements of this chapter and the approved engineering design. Alternatively, the administrative authority may issue a certificate of compliance if a licensed professional engineer submits to the administrative authority, a statement in writing, signed and sealed by him or her that the said system has been located, constructed, installed or altered in compliance with the requirements of these standards and the approved engineering design.

(b) The administrative authority or authorized agent may require additional permeability tests to be conducted, the disposal field excavation to be deepened, fill material to be added or other changes to be made in the installation of the system if, during the course of excavation, soil limitations not identified previously are discovered. Such changes shall be made as prescribed in N.J.A.C. 7:9A-3.7.

(c) A component of an individual subsurface sewage disposal system shall not be backfilled or otherwise concealed from view until a final inspection has been conducted by the administrative authority or its authorized agent, or a licensed professional engineer, and permission has been granted by the administrative authority to backfill the system. Any component of the system which has been covered without such permission shall be uncovered upon the order of the administrative authority or its authorized agent.

(d) A person shall not commence operation or use of an individual subsurface sewage disposal system until a certificate has been issued by the administrative authority or its authorized agent indicating that said system has been located, constructed, installed or altered in compliance with this chapter. The issuance of a certificate of compliance shall constitute only certification that the individual subsurface sewage disposal system has been constructed, located, installed or altered in conformance with this chapter. It shall not be construed as a guarantee that the system will function satisfactorily, nor shall it in any way restrict the powers or responsibilities of the administrative authority or the Department in the enforcement of any law or ordinance relating to public health and safety or environmental protection.

(e) The administrative authority or its authorized agent shall give to the building inspector or similar official of the municipality who is responsible for the issuance of occupancy permits a copy of the certificate of compliance.

7:9A-3.14 Notification of proper operation and maintenance practices

(a) The administrative authority shall notify each property owner issued approval for the design, construction, installation, alteration or repair of an individual subsurface sewage disposal system after January 1, 1990 of the proper operation and maintenance practices.

(b) Written notification of the proper operation and maintenance practices shall initially be issued to the applicant with the approval for the location, design, construction, installation, alteration or repair of the individual subsurface sewage disposal system and reissued on a triennial basis to the present property owner. For approvals issued before June 21, 1993, the notification shall be accomplished by December 21, 1993 and reissued on a triennial basis, thereafter.

(c) The written notification shall inform the present property owner how to properly operate and maintain an individual subsurface sewage disposal system. A mass mailing to all property owners who have individual subsurface sewage disposal systems is an acceptable method of notice. The notice shall include, at a minimum:

1. A general outline of how an individual subsurface sewage disposal system works and the potential impact of improper operation and maintenance on system performance, ground and surface water quality, and public health;
2. The recommended frequency of septic tank and grease trap pumping to prevent over-accumulation of solids, and methodology for inspection to determine whether pumping is necessary;
3. A list of materials containing toxic substances which are prohibited from being disposed of into an individual subsurface sewage disposal system;
4. A list of inert or non-biodegradable substances which should not be disposed of within an individual subsurface sewage disposal system;
5. Proper practices for maintaining the area reserved for sewage disposal;
6. Impacts upon system performance resulting from excessive water use; and
7. Warning signs of poor system performance or malfunction and recommended or required corrective measures.

(d) The written notification may be developed by the administrative authority, or the administrative authority may distribute copies of an operation and maintenance manual made available by the Department.

Repeal and New Rule: R.1993 d.294, effective June 21, 1993.
See: 24 N.J.R. 1987(a), 25 N.J.R. 2704(b).

7:9A-3.15 Records

(a) The administrative authority or its authorized agent shall maintain records and shall keep on file copies of the following documents:

1. Applications and plans and specifications for the construction, installation or alteration of individual subsurface sewage disposal systems, including all forms and data submitted by the applicant;
2. Permits issued for the construction, installation or alteration of individual subsurface sewage disposal systems;
3. Modifications to plans made subsequent to the issuance of a permit to construct, install or alter individual subsurface sewage disposal systems;
4. Reports of construction inspections made prior to issuance of a certificate of compliance for an individual subsurface sewage disposal system;
5. Certificates of compliance issued for individual subsurface sewage disposal systems;
6. Inspection reports, plans and specifications for repair or alteration of malfunctioning individual subsurface sewage disposal systems or components of malfunctioning systems.

(b) Files containing records or documents listed in (a) above shall be available upon request for inspection by personnel of the Department.

(c) The administrative authority or its administrative agent shall maintain records until such time as the realty improvement served by the proposed or existing subsurface sewage disposal system is removed or connected to a public sewer.

Amended by R.1993 d.294, effective June 21, 1993.
See: 24 N.J.R. 1987(a), 25 N.J.R. 2704(b).

7:9A-3.16 Prior tests

(a) Percolation test results, soil logs and determinations of seasonally high water table made prior to January 1, 1990 may be used as a basis for design and location of an individual subsurface sewage disposal system for five years following January 1, 1990 provided that the following conditions are met:

1. Such tests complied with the rules in effect at the time they were performed; and
2. All other aspects of the system proposed are in compliance with the requirements of this chapter.

Amended by R.1992 d.187, effective April 20, 1992.
See: 24 N.J.R. 202(a), 24 N.J.R. 1491(a).

Extended from two to five years the period of time for which field testing, conducted before January 1, 1990, may be incorporated into septic system designs.

7:9A-3.17 Registration of personnel

(a) The Department will establish a voluntary registration program for individuals involved in subsurface sewage disposal system site evaluation, design, construction, inspection and regulation. The purpose of the registration will be to provide a means for the Department to disseminate technical information and training to professional engineers, health officers, sanitarians, soil scientists, contractors, septic tank pumpers and other individuals involved in implementation of these standards.

(b) Individuals wishing to be registered shall contact the Department in writing and indicate the categories for which registration is sought. Registration categories shall be as follows:

1. The "septic system enforcement officer" category includes licensed professional engineers, licensed health officers or licensed sanitarians, acting as the authorized agent for the administrative authority, who approve, permit, certify or license the construction, installation, alteration, repair or operation of individual subsurface sewage disposal systems or who review engineering plans, witness site evaluation and testing, inspect construction or make any determinations relied upon for the granting of such approvals, permits, certifications or licenses.
2. The "site evaluator" category includes licensed professional engineers, licensed health officers, licensed sanitarians or soil scientists who perform site evaluation, soil evaluation or soil testing as prescribed in N.J.A.C. 7:9A-4, 5 and 6.

3. The "septic system designer" category includes licensed professional engineers who prepare engineering plans and specifications for the construction or alteration of individual subsurface sewage disposal systems.

4. The "septic system installer" category includes persons who construct, install or alter individual subsurface sewage disposal systems in accordance with approved engineering plans and specifications or who repair systems as allowed in N.J.A.C. 7:9A-3.3(d).

5. The "septic system inspector" category includes solid waste haulers registered with the Department in accordance with N.J.A.C. 7:26-3, licensed professional engineers, licensed health officers or licensed sanitarians who perform inspections of individual subsurface sewage disposal systems as required in N.J.A.C. 7:9A-12.2.

7:9A-3.18 Additional requirements for certification of sewerage facilities serving subdivisions involving more than 10 realty improvements

(a) Applications for certification by the administrative authority, pursuant to N.J.S.A. 58:11-25, of sewerage facilities serving subdivisions, regardless of the number of realty improvements involved, shall contain the basic information required in N.J.A.C. 7:9A-3.5(c) for each individual realty improvement contained in the subdivision. Where more than 10 realty improvements are involved, additional information is required as set forth in (c) below.

(b) Where 50 or more realty improvements are involved, two separate certifications are required. The first of these is a water quality standards related certification issued by the Department pursuant to N.J.S.A. 58:11-25.1, prior to planning board approval, as prescribed in (d) below. The second of these is a design and construction certification, issued by the administrative authority pursuant to N.J.S.A. 58:11-25, prior to issuance of building permits and reviewed by the Department and the administrative authority simultaneously, as prescribed in (f) below.

(c) For certifications pursuant to N.J.S.A. 58:11-25, of sewerage facilities proposed to serve subdivisions consisting of more than 10 realty improvements, the following information is required in addition to the information required by N.J.A.C. 7:9A-3.5(c). This additional information shall be provided on a general site plan of the subdivision, signed and sealed by a licensed land surveyor:

1. Lots with their dimensions and acreage;

2. Contours of existing topography (at an appropriate contour interval) using absolute elevations or relative elevations referenced to a permanent bench-mark;

3. Drainage right of way and any contemplated diversion thereof;

4. Location of all existing and proposed water supply wells within 500 feet from the boundaries of the subdivisions;

5. Streams and surface water bodies;

6. Existing and proposed storm sewers and subsurface drains;

7. Above and below ground power transmission lines, gas pipe lines and associated right-of-ways;

8. Location of all stream encroachment boundaries and 100-year flood plain boundaries which fall within the boundaries of the subdivision;

9. Location of all State approved wetlands or transition area delineation lines which fall within the boundaries of the subdivision;

10. Location of all profile pits, soil borings, permeability or percolation tests made within the area of the subdivision; and

11. Boundaries of all soil types or mapping units, obtained from detailed onsite soil investigations or transferred from USDA County Soil Survey Report.

(d) No subdivision approval shall be granted by any municipal or other authority in the State to cover 50 or more realty improvements, or less than 50 where the subdivision extends into an adjoining municipality or municipalities and will, in the aggregate, cover 50 or more realty improvements, until the Department has certified that the proposed sewerage facilities for realty improvements comply with applicable State standards.

(e) (Reserved)

(f) Copies of all applications and accompanying engineering data for certifications submitted under N.J.S.A. 58:11-25 to cover 50 or more realty improvements shall be filed with or mailed to the Department on the date the application is made to the administrative authority.

(g) Copies of all certifications issued by administrative authorities under N.J.S.A. 58:11-25 covering 50 or more realty improvements shall be mailed to the Department by the administrative authority issuing the same on the date of issue.

(h) In cases where preliminary determination by the administrative authority regarding the acceptability of the proposed sewage disposal systems may be required prior to the granting of subdivision approval by the planning board or other municipal agency, such determinations may be made based upon the type of disposal field installations proposed and the soil suitability classification determined by use of Soil Conservation Service soil survey maps in conjunction with Appendix D of this chapter. Alternatively, onsite soil evaluation consisting of soil logs and permeability tests may be required. Where onsite soil evaluation is required, a minimum of one soil log for every five acres or fraction thereof shall be sufficient provided that at least one soil log is provided for every soil series present within the area of the subdivision as shown on Soil Conservation Service soil survey maps. The number of permeability tests required shall be a minimum of one test for every five acres or fraction thereof.

7:9-3.19 Entry and inspection

The administrative authority and its agent and the Department shall have power to make, or cause to be made, such inspections and tests as may be necessary to enforce these standards and they and their authorized representatives shall at all times have the right to enter upon lands of realty improvements for these purposes. The system owner shall not refuse, prevent or otherwise prohibit such tests and inspections to determine compliance with this chapter.

7:9A-3.20 Hearing procedures

In case any certification is denied by the administrative authority, a hearing shall be held thereon before the administrative authority within 15 days after request therefor is made by the applicant. Upon such hearing, the administrative authority shall affirm, alter or rescind its previous determination and take action accordingly within 15 days after the date of such hearing.

SUBCHAPTER 4. SITE EVALUATION AND SYSTEM LOCATION

7:9A-4.1 General provisions for site evaluation and system location

(a) Selection of a location for each individual subsurface sewage disposal system shall be based upon evaluation of all site characteristics which may affect the functioning of the system. Site characteristics to be evaluated shall include, but may not be limited to, minimum required separation distances as prescribed in N.J.A.C. 7:9A-4.3, slope, surface drainage and flood potential.

(b) A site plan shall be required as part of each application and shall, as a minimum, provide the information outlined in N.J.A.C. 7:9A-3.5(c)2.

7:9A-4.2 Location generally

(a) The location and installation of each individual subsurface sewage disposal system and every part thereof shall be such that with reasonable maintenance, as required by N.J.A.C. 7:9A-12, it will function in a satisfactory manner and will not create a nuisance or source of foulness, pose a threat to public health or safety or the environment, or otherwise adversely affect the quality of surface water or groundwater.

(b) Individual subsurface sewage disposal systems shall not be located in such a manner that their functioning may be adversely affected by the following features unless the design adequately addresses the special limitations associated with these features and complies with all applicable local, State and Federal laws, regulations and ordinances.

1. Bedrock outcrops or areas with excessive stones;
2. Sink-holes;
3. Steep slopes showing signs of unstable soil such as landslide scars, slump blocks, fence posts or lower trunks of trees bending downslope;
4. Bare eroded ground, denuded of vegetation, or with deep wheel ruts;
5. Highly disturbed ground indicated by such features as remnants of foundations or pavements, buried building debris or buried plant remains;
6. Sand dunes;
7. Mine spoils, borrow pits, dumps or landfills;
8. Low-lying coastal areas exhibiting signs of tidal inundation or tidal marsh vegetation such as cordgrass (*Spartina alterniflora*), salt-meadow grass (*Spartina patens*) or spike grass (*Distichlis spicata*);
9. Low-lying inland areas showing signs of ponding or freshwater wetland vegetation such as skunk cabbage (*Symplocarpus foetidus*), tussock sedge (*Carex stricta*), cat-tails (*Typha* spp.), alders (*Alnus* spp.), or white cedar (*Chamaecyparis thyoides*); and
10. Flat low-lying areas adjoining streams.

7:9A-4.3 Distances

The minimum separation distance between the various components of the system and the other features listed shall conform with Table 4.3 below. The location of a new well must be in conformance with the requirements of N.J.A.C. 7:10-12.13.

Table 4.3 Minimum Required Separation Distances (feet)

Component	Reservoir, Well or Suction Line	Water Service Line, Pressure	Water-course ⁽¹⁾	Occupied Building	Property Line	Disposal Field	Existing Seepage Pit or Cesspool	In-ground Swimming Pool
Building Sewer	25 ⁽²⁾	5	—	—	—	—	—	—
Septic Tank	50 ⁽²⁾	10	25 ^(2,5)	10 ⁽⁶⁾	5	—	—	10
D-Box	50 ⁽²⁾	10	25 ^(2,5)	10	5	—	—	10
Disposal Field ⁽¹¹⁾	100 ^(2,4)	10	50 ^(2,3,5)	25 ⁽⁷⁾	10	50 ⁽⁸⁾	50	20
Seepage Pit ⁽⁹⁾	150 ⁽²⁾	25	100 ^(2,5)	50 ⁽⁷⁾	20	50	50 ⁽¹⁰⁾	30
Dry Well	—	—	—	—	—	50	50	—

(1) Includes subsurface drains with an above-ground or surface water outlet.

(2) Where excessively coarse soils or fractured rock substrata are encountered, these distances may be increased by the administrative authority.

(3) This distance may be decreased only in the case of an interceptor drain as allowed in N.J.A.C. 7:9A-10.7(d).

(4) This distance may be decreased by the administrative authority to a minimum of 50 feet only when the well is provided with a water-tight casing to a depth of 50 feet or more, and where the casing is sealed into an impervious stratum which separates the water-bearing stratum from the layer of soil used for sewage disposal. N.J.A.C. 7:10-12.13 shall govern whenever the well under consideration has been installed after July 13, 1979.

(5) These distances may be reduced by one-half if the water course is a footing drain with an invert elevation higher than the bottom of the disposal field or more than four feet above the level of the seasonally high water table.

(6) May be reduced to five feet with special approval of the administrative authority.

(7) May be reduced to 15 feet from disposal field and 30 feet from seepage pit for portions of the building constructed either on a slab foundation or over a continuous dust cap which is at or above natural or finished grade, whichever is higher only.

(8) This distance applies to disposal fields serving separate realty improvements but not to disposal fields which are part of a split system serving a single realty improvement.

(9) Applies only to seepage pits allowed as prescribed in N.J.A.C. 7:9A-7.6.

(10) In no case shall the distance be less than three times the pit diameter.

(11) These distances shall be measured from the margin of the filled area in the case of soil replacement and mounded soil replacement installations or the edge of the required lateral fill extension in the case of mounded installations.

7:9A-4.4 Slope

(a) The disposal field or seepage pit shall not be located in an area where the slope is greater than 25 percent.

(b) Where the slope is greater than 10 percent, no disposal field or seepage pit shall be placed less than 50 feet upslope of any bedrock outcrop where signs of ground water seepage can be detected.

(c) Modification of slopes by re-grading shall meet the requirements of N.J.A.C. 7:9A-10.3(b).

7:9A-4.5 Surface drainage

(a) No disposal area shall be placed within a topographical depression or in any area where surface runoff or ground water is likely to accumulate unless measures adequate to address these limitations are incorporated in the approved engineering design and implemented when the system is constructed.

(b) The use of swales to divert surface run-off away from the disposal field shall be carried out only as prescribed within the engineering design which has been approved by the administrative authority.

(d) When it is required, the hydraulic head test shall be conducted only during the months of January through April inclusive, and shall be witnessed by the administrative authority or its authorized agent in accordance with N.J.A.C. 7:9A-3.6. Whenever the Department determines that there has been a significant departure from normal climatic conditions, the Department may, with prior written notice to the administrative authority, lengthen or shorten the period allowed for use of this test during any given year.

(e) When piezometers are installed for the purpose of conducting this test, the piezometers shall be removed or filled with cement grout after completion of the test except in those cases where the piezometers will be utilized for monitoring ground water levels or for ground water sampling as required by the administrative authority or by the Department. Piezometers used for monitoring ground water levels over extended periods of time, or for ground water sampling in connection with water quality monitoring, may be considered to be monitoring wells requiring installation by a licensed well driller and a permit issued by the Department pursuant to State law (N.J.S.A. 58:4-1 et seq.). The applicant shall contact the Department for a determination of whether or not a permit is required.

7:9A-5.10 Disturbed ground

(a) When placement of a disposal field is proposed in an area of disturbed ground, the type and depth of soil limiting zones as well as a variety of additional factors must be considered in determination of soil suitability, depending on the nature of the soil disturbance, as outlined in (b) below. Types of soil disturbance which shall be addressed within the soil evaluation and engineering design include but are not limited to filled areas, excavated areas, re-graded areas, artificially drained areas and pre-existing wastewater disposal areas.

(b) A site shall be considered disturbed ground when any of the following conditions are present:

1. Displaced or man-made objects such as tree stumps, branches, plant stems, leaves, building debris or trash of man-made origin, are observed below the ground surface in profile pits or soil borings;
2. Soil profile pits or borings reveal A-horizons or O-horizons which are buried by layers of soil or other material;
3. Soil horizons are absent or mixed in a manner which cannot be explained as a result of natural processes;
4. Mounded areas or depressions in the land surface are observed which do not conform with surrounding topography and which show signs of recent disturbance such as lack of vegetation, weedy vegetation, severe erosion, wheel ruts, etc.;

5. Remnants of building foundations, pavement or other man-made structures are observed at the surface or uncovered in profile pits or soil borings;

6. Subsurface drains or their remnants are observed in profile pits or borings or the outlets of drains are observed at the surface; or

7. Components of an existing wastewater disposal system, or remnants of an abandoned sewage disposal system are present below the site of a proposed new system.

(c) When evidence is found that the surface of the ground may have been modified by a disturbance such as addition of fill material, removal of soil horizons or re-grading, the pre-existing natural ground surface shall be identified based upon the following criteria:

1. When a buried A- or O-horizon is present, the pre-existing natural ground surface shall be taken as the top of the A-horizon or the bottom of the O-horizon.

2. When a buried A- or O-horizon is not present, the level of the pre-existing natural ground surface shall be determined by extrapolation from adjacent areas beyond the limit of soil disturbance. When this method is relied upon, the nature of the pre-existing topography as well as the nature of the ground disturbance shall be described, using topographic contour maps and profiles where appropriate, to the satisfaction of the administrative authority.

(d) In cases where disturbed soil or other fill material are present at the site, the suitability of this material shall be evaluated based upon its composition and its physical stability as follows:

1. Fill materials containing more than trace amounts of the following types of materials, or any other materials which are subject to disintegration or change in volume, shall be considered unsuitable:

- i. Tree stumps, plant stems, leaves, food or animal remains or wastes, wood chips, saw dust, or any organic materials which may be subject to decay;
- ii. Trash, discarded furniture, building or demolition debris or any bulky objects containing large voids or subject to collapse or re-orientation; or
- iii. Cans, bottles, drums or any containers which are empty or filled with liquids.

2. Layers of fill material which do not contain materials as described in (d)1 above but which do contain coarse fragments in excess of 50 percent by volume shall be considered excessively coarse horizons or substrata. In the case of disturbed ground, coarse fragments may include man-made or artificial materials as well as rock fragments which are larger than two millimeters in diameter, provided that the man-made materials are limited only to physically and chemically inert materials without large voids, such as brick, concrete or glass fragments.

3. When construction of a wastewater disposal field is proposed within disturbed ground, an acceptable state of compaction of the soil or fill material shall be verified by laboratory tests of samples taken from within the area of the proposed disposal field. Based upon the results of these tests, the design engineer shall certify to the administrative authority that the in-place dry density of the soil or fill material above which the proposed system will be located is a minimum of 90 percent of the Standard Procter Density determined by laboratory analysis.

(e) In cases where the surface of the ground has been raised by the addition of fill material or lowered by the removal of pre-existing soil horizons, soil suitability shall be determined based upon the depth to limiting zones measured from the pre-existing natural ground surface determined as prescribed in (c) above, or the existing ground surface, whichever is lowest.

(f) Ground containing subsurface drainage systems or remnants of abandoned subsurface drainage systems shall be considered unsuitable for the installation of a disposal field unless the drains will be removed or the outlets of the drainage system permanently sealed. Any subsurface drain which has a surface outlet shall be considered as a water-course and is subject to minimum horizontal setback distances from waste disposal system components as set forth in N.J.A.C. 7:9A-4.3.

(g) Ground containing existing wastewater disposal systems or remnants of abandoned systems shall be considered unsuitable for the installation of a disposal field unless the pre-existing system will be removed prior to installation of the proposed new system.

(b) The administrative authority may require additional tests at depths other than the depth of infiltration when doubt exists regarding the presence or the type of a limiting zone.

(c) The type of tests which may be used shall be determined based upon the purpose of the test and the soil conditions at the depth of the test as shown in Table 6.1 below.

Table 6.1 Type of Test

Test Options: 1—Tube Permeameter Test 2—Soil Permeability Class Rating Test [†] 3—Percolation Test 4—Basin Flooding Test 5—Pit-bailing Test 6—Piezometer Test	Acceptable Test Options
Purpose of Test and Soil Conditions at Depth of Test	
I. Determination of Design Permeability at Level of Infiltration, Identification of Hydraulically Restrictive or Excessively Coarse Horizons or Substrata Above the Water Table	
A. Sands and loamy sands with single grain structure	1, 2 or 3
B. Other soil textures	
1. Undisturbed sample can be taken	1, 2 or 3
2. Undisturbed sample cannot be taken	2 or 3
II. Identification of Massive Rock Substrata Above the Water Table	
	4
III. Identification of Hydraulically Restrictive Horizons or Substrata and Massive Rock Substrata Below the Water Table	
	5 or 6
IV. Design of Seepage Pits	
	3

[†]This test shall not be used in soil horizons or substrata containing coarse fragments in excess of 50 percent by volume or 75 percent by weight.

(d) The number and location of permeability tests required shall be as follows:

1. When the tube permeameter test or the soil permeability class rating test are used to determine the design permeability at the level of infiltration, a minimum of one test shall be conducted within each disposal field and each test shall consist of a minimum of two test replicates. The administrative authority shall require additional tests or more than two replicates per test where the variability of test results exceeds the limits allowed in N.J.A.C. 7:9A-6.2(i)2, or where the results of soil profile pits or borings, made as prescribed in N.J.A.C. 7:9A-5.2, indicate the presence of more than one soil type within the area of the disposal field. When soil tests taken in different parts of the disposal field yield different results, the system shall be designed based upon the most restrictive conditions found within the area of the disposal field.

2. When the basin flooding test, the pit-bailing test or the piezometer test are required for identification of limiting zones, a minimum of one test shall be required within or no further than 15 feet beyond the boundaries of each disposal field. The administrative authority may require more than one test where conditions vary from one part of the disposal field to another.

SUBCHAPTER 6. PERMEABILITY TESTING

7:9A-6.1 General provisions for permeability testing

(a) The design permeability is the basis for determining the minimum required area of the disposal field. Tests shall be required at the site of each disposal field, at the level of infiltration, for determination of the design permeability. Where a conventional disposal field will be installed, tests shall be conducted at a depth of one to three feet below the ground surface, within the soil horizon in which the bottom of the disposal field will be placed. When a soil replacement, mound, or mounded soil replacement installation is proposed, a percolation test shall be conducted within the fill material after it has been emplaced and compacted, or a tube permeameter test shall be conducted using samples of the fill material which have been compacted to a bulk density equivalent to that achieved in the construction of the disposal field. In lieu of this, the permeability class rating method may be used to determine whether the fill material used meets the requirements of N.J.A.C. 7:9A-10.1(f)4.

3. Step Three: Stretch a piece of muslin cloth over the bottom of the sampling tubes and place the tubes on a flat surface. Slowly pour the soil into each sampling tube while gently tapping the side of the tube with a hard instrument. Fill the tubes to a depth of three to four inches. Check the bulk density of the sample by dividing the weight of the sample (weight of sample tube containing sample minus the weight of empty sample tube) by the volume of the sample (length of sample multiplied by $3.14 r^2$, where r is the internal radius of the sample tube). The minimum acceptable bulk density for disturbed samples is 1.2 grams per cubic centimeter.

(f) The following procedure shall be used for pre-soaking undisturbed or disturbed core samples for the tube permeameter test:

1. Step One: Place the soil core in the pre-soak basin and fill the basin with water to a point just below the top of the soil core. Never fill the basin to a level which is higher than the top of the soil core. Never use water directly from the tap to soak cores. Use only de-aired water as prescribed in (a)13 above. Allow the sample to soak until the top surface of the core is saturated with water. This may require only a few minutes of soaking for sandy textured soils or several days for clay textured soils. Failure to soak the sample for sufficient time may result in greatly reduced permeability measurements due to entrapped air.

2. Step Two: When the sample has soaked for sufficient time, place a one inch layer of fine gravel (from two to 10 millimeters in diameter) on top of the soil core in the sampling tube. Slowly fill the tube with de-aired water taking care not to disturb the surface of the core. A small spatula or similar implement may be used to break the fall of the water as it is poured into the tube.

3. Step Three: Immediately transfer the soil core to the test basin in which a layer of gravel has been placed and gently press the soil core into the gravel so that it stands vertically with its base positioned at the desired depth below the rim of the test basin.

(g) The following procedure shall be used to conduct the tube permeameter test:

1. Step One: When the soil core has been positioned at the desired height within the test basin (see Figure 5 of Appendix A), fill the test basin to overflowing with de-aired water. (Note: The hydraulic head used in the test depends upon the height of the top of the sample tube or standpipe above the rim of the test basin as shown in Figure 5. In general, a higher hydraulic head should be used for heavy textured soils to expedite the test and a lower head should be used for sandy textured soils to prevent an excessively fast flow rate).

2. Step Two: Fill the tube to overflowing with de-aired water and record the time, in minutes, required for the water level in the tube to drop a standard distance

such as one-half inch, one inch, or two inches. Repeat this step until the rate of fall becomes constant or the difference between the highest and lowest of three successive readings is less than five percent. When the readings are less than 20 minutes in length the time should be reported to the nearest second.

3. Alternate Step Two: When the rate of fall observed in "Step Two" ((g)2 above) is slow, the flow rate may be increased by use of a standpipe as shown in Figure 5. Carefully insert the standpipe into the top of the sample tube and fill with de-aired water. The apparatus should be checked for leaks where the standpipe fits into the sample tube. Silicon jelly, petroleum jelly or a similar material may be used to prevent leakage. Measure the rate of fall of the water level in the standpipe as in Step Two.

(h) The permeability of each replicate sample tested shall be calculated using the following formula:

$$1. K (\text{in/hr}) = 60 \text{ min/hr} \times L(\text{in})/T(\text{min}) \times r^2/R^2 \times 1n(H_1/H_2)$$

Where:

K is the permeability of the soil sample;

L is the length of the soil core, in inches;

T is the time, in minutes, required for the water level to drop from H_1 to H_2 during the final test interval;

r is the radius of the standpipe, in centimeters or inches;

R is the radius of the soil core, in the same units as "r";

1n is the natural logarithm

H_1 is the height of the water level above the rim of the test basin at the beginning of each test interval, in inches; and

H_2 is the height of the water level above the rim of the test basin at the end of each test interval, in inches.

Note: When the standpipe is not used, the term r^2/R^2 is omitted from the equation.

(i) Variability of test results shall be evaluated as follows:

Measured Permeability Greater than	Soil Permeability Class
20 inches per hour ("in/hr")	K5
6-20 in/hr	K4
2-6 in/hr	K3
0.6-2 in/hr	K2
0.2-0.6 in/hr	K1
Less than 0.2 in/hr	K0

2. The variability of soil permeability test results shall be considered acceptable only where the results of all

replicate tests fall within one soil permeability class or two adjacent permeability classes.

3. Where the results of replicate tests differ by more than one soil permeability class, the samples shall be examined for the following defects:

i. Cracks, worm channels, large root channels or poor soil tube contact within the sample yielding the highest permeability value(s);

ii. Large pieces of gravel, roots or unsaturated soil within the interior of the sample yielding the slowest permeability value(s); or

iii. Smearing or compaction of the upper or lower surface of the sample yielding the lowest permeability value(s).

4. If any of the defects described in (i)3 above are found, the defective core(s) shall be discarded and the test repeated using a new replicate sample for each defective replicate sample.

(j) When test results have been obtained with an acceptable range of variability as defined in (i) above, the results shall be interpreted as follows:

1. When the purpose of the test is to determine the design permeability at the level of infiltration, the slowest of the test replicate results shall be used for design purposes.

2. When the purpose of the test is to identify a hydraulically restrictive horizon or substratum above the water table, the horizon or substratum in question shall be considered hydraulically restrictive if the average permeability of the replicate samples tested falls within soil permeability class KO as defined in (i)1 above.

3. When the purpose of the test is to identify an excessively coarse horizon or substratum above the water table, the horizon or substratum in question shall be considered excessively coarse if the average permeability of the replicate samples tested falls within permeability class K5 as defined in (i)1 above.

(k) Where results of replicate tests exceed the limits of variability allowed in (i)2 above, the results shall be interpreted as follows:

1. When the purpose of the test is to determine the design permeability at the depth of infiltration, the slowest of the test replicate results shall be used for design purposes.

2. When the purpose of the test is to identify a hydraulically restrictive horizon or substratum above the water table, the horizon or substratum in question shall be considered hydraulically restrictive if the slowest permeability of the replicate samples tested falls within soil permeability class KO as defined in (i)1 above.

3. When the purpose of the test is to identify an excessively coarse horizon or substratum above the water table, the horizon or substratum in question shall be considered excessively coarse if the fastest permeability of the replicate samples tested falls within permeability class K5 as defined in (i)1 above.

7:9A-6.3 Soil permeability class rating

(a) Determination of permeability by the soil permeability class rating technique is based upon a hydrometer analysis performed as prescribed in (f) below, and a sieve analysis performed as prescribed in (g) below, together with evaluation of soil morphological properties as prescribed in N.J.A.C. 7:9A-5.2 and 5.3. As an alternate to the hydrometer analysis procedure prescribed in (f) below, the hydrometer analysis procedure given in ASTM STANDARD D 422, published by the American Society for Testing and Materials, may be used to determine the percent by weight of sand and the percent by weight of clay in the sample.

(b) The following equipment is required:

1. A two-millimeter sieve, with an eight inch or larger diameter frame;

2. A set of two sieves, with five inch or larger diameter frames, with covers and pans. The sieves shall meet the following specifications:

i. The first sieve shall be 0.25 millimeter, 60-mesh, Bureau of Standards, phosphor bronze wire cloth; and

ii. The second sieve shall be 0.047 millimeter, 300-mesh, Bureau of Standards, phosphor bronze wire cloth (0.0015wire);

3. A wooden rolling pan or mortar with rubber-tipped pestle;

4. An oven;

5. A scale (0.1 gram accuracy);

6. Distilled water;

7. A sodium hexametaphosphate solution of 50 grams of the salt dissolved in one liter of distilled water;

8. The electric mixer (see section 2.1.1 of ASTM Standard D 422) or mechanical shaker;

9. A 1000 milliliter graduated cylinder with rubber stopper;

10. A soil hydrometer calibrated to read in grams per liter at 68 degrees Fahrenheit (ASTM # 152H);

11. A thermometer;

12. A clock with second hand; and

13. A sieve shaker

(c) A loose sample of soil, 200 grams or more, shall be collected from the soil horizon or substratum to be tested.

(d) The soil sample shall be prepared as follows:

1. Pass the soil sample to be tested, which has been allowed to air dry, through a two millimeter sieve to remove coarse fragments. Use moderate pressure with a wooden rolling pin or mortar with rubber-tipped pestle to break soil aggregates (but not soft rock fragments) which are larger than two millimeters.

2. Weigh both the material retained and the material which passes through the sieve. This method shall not be used where the weight of coarse fragments retained on the sieve exceeds 75 percent of the total sample weight.

3. Discard the coarse fragments.

(e) Dispersion of the soil sample shall be accomplished using a motor-mixed or a reciprocating shaker as prescribed below. This procedure shall be followed for each replicate sample tested.

1. Step One: Place 40 grams of air dry soil which has been passed through a two millimeter sieve into a mixing cup or one liter shaker bottle together with 100 milliliters of sodium hexametaphosphate solution and 400 milliliters of distilled water. Weigh out an additional 40 gram sample for determination of oven dry weight. Re-weigh the latter sample after keeping it in an oven at 105 degrees Centigrade for 24 hours. (Only one sample is required for determination of oven-dry weight regardless of the number of replicate samples used for the hydrometer analysis).

2. Step Two: If a motor mixer is used, allow the soil to soak in the cup for 10 minutes, place the cup on the mixer and mix the sample for five minutes. Next, transfer the suspension completely to the cylinder. Rinse the mixing cup with distilled water and pour the rinse water into the cylinder so that none of the suspension is left in the mixing cup. Bring the volume of the suspension in the cylinder up to the 1000 milliliter mark with distilled water. Allow the suspension to reach room temperature.

3. Alternate Step Two: If a reciprocating shaker is used in lieu of the mixer, shake the sample for 12 hours, at a rate of approximately 120 strokes per minute, and transfer to the cylinder rinsing the shaking bottle's with distilled water. Bring the volume of the suspension in the cylinder to the 1000 milliliter mark with distilled water. Allow the suspension to reach room temperature.

(f) The following procedure shall be used for the hydrometer analysis:

1. Step One: Calibrate the hydrometer as follows: Add 100 milliliters of sodium hexametaphosphate solution to a 1000 milliliter cylinder and fill to the 1000 milliliter mark with distilled water. Place the stopper in the cylinder and shake vigorously in a back and forth motion. Place the cylinder on the table and lower the hydrometer into the solution. Determine the scale reading at the upper edge of the meniscus surrounding the hydrometer

stem. This is the hydrometer calibration, Rc. Record the temperature in degrees Fahrenheit (°F).

2. Step Two: Place a stopper in the cylinder containing the dispersed soil sample, shake the cylinder using a back and forth motion (avoid causing circular currents in the cylinder) and place the cylinder on the table. Record the time immediately. After 20 seconds carefully lower the hydrometer into the cylinder and, after exactly 40 seconds, read the hydrometer. Repeat this step until two successive readings are obtained which agree within 0.5 gram per liter.

3. Step Three: Determine the temperature of the suspension and correct the hydrometer reading as follows:

i. Subtract the reading obtained in Step One, Rc, from the hydrometer reading.

ii. For each degree Fahrenheit above 68 add 0.2 gram to the reading or for each degree Fahrenheit below 68 subtract 0.2 gram.

4. Step Four: Remove the hydrometer, stopper the cylinder, and shake the hydrometer as in Step Two. Remove the stopper and immediately place the cylinder on a table where it will not be disturbed. Take a hydrometer reading after exactly two hours and correct the hydrometer reading as in Step Three.

5. Step Five: Using test data reporting forms provided in Appendix B, record, the following data:

i. Oven dry weight of soil, Wt (from Step One of (e) above);

ii. Hydrometer calibration, Rc (Step One);

iii. Hydrometer reading at 40 seconds, R1 (Step Two);

iv. Temperature of suspension (Step Three);

v. Corrected hydrometer reading, R1' (Step Three);

vi. Hydrometer reading at two hours, R2' (Step Four); and

vii. Corrected hydrometer reading, R2' (Step Four);

6. Step Six: Calculate the percent of sand and percent of clay as follows:

i. Percent of sand = $(Wt.-R')/Wt. \times 100$

ii. Percent of clay = $R2'/Wt. \times 100$

NOTE: The hydrometer analysis may not be carried out in a room where the temperature varies more than two degrees during the time required to perform the test.

(g) A sieve analysis shall be performed as prescribed below for each replicate sample used in the hydrometer analysis except when the content of sand determined as prescribed in Step Six of (f) above is less than 25 percent.

1. Step One: After the completion of Step Four in (f) above, pour the suspension from the sedimentation cylinder into a 0.047 millimeter sieve and wash the fine material through the sieve using running water.

2. Step Two: Dry the sieve and its contents in an oven. Cool the sieve and transfer the sand to a pre-weighed evaporating dish (or similar heat resistant vessel) carefully, using a soft brush.

3. Step Three: Place the dish and its contents in an oven at 105 degrees Centigrade, for two hours, to dry. Cool the dish and its contents and weigh to the nearest 0.01 gram. Determine the weight of the sand by subtracting the weight of the dish.

4. Step Four: Assemble a stack of sieves as specified in (a)2 above, consisting of the pan, the 0.047 millimeter sieve and the 0.25 millimeter sieve, from bottom to top, respectively. Inspect sieves carefully before using to make sure that they are clean and undamaged. Transfer the sand from the evaporating dish to the top sieve using a soft brush to complete the transfer.

5. Step Five: Put the cover on the top sieve, firmly fasten the sieves to the sieve shaker and shake for three minutes. Disassemble the stack of sieves, transfer the contents of each sieve to a weighing dish separately. Weigh the contents of each sieve to the nearest 0.01 gram. Record the following data:

- i. Total weight of sand fraction, from Step Three;
- ii. Weight of sand passing the 0.25 millimeter sieve (retained in the 0.047 millimeter sieve);
- iii. Percent fine plus very fine sand: Divide weight of sand passing 0.25 millimeter sieve by total weight of sand fraction and multiply this value by 100.

(h) The following procedure shall be used to determine the soil permeability class:

1. Step One: Using the soil permeability/textural triangle, Figure 6 of Appendix A, determine the soil permeability class of the soil horizon being tested, based upon the average percentage of sand and the average percentage of clay in the replicate samples tested as prescribed in (f) above.

2. Step Two: If the average percentage of fine plus very fine sand in the replicate samples tested, determined as prescribed in Step Five of section (g) above, is 50 percent or greater, adjust the permeability class determined in Step One of this subsection to the next slowest class.

3. Step Three: If the soil horizon being tested is found to have a massive or platy structure or a hard, very hard, firm, very firm or extremely firm consistence, determined as prescribed in N.J.A.C. 7:9A-5.3, adjust the permeability class determined in Step One of this subsection to the next slowest class.

7:9A-6.4 Percolation test

(a) The following equipment is required for the percolation test:

1. A soil auger, post-hole digger or other means of preparing a test hole as prescribed in (b) below;
2. A knife or trowel for removing smeared or compacted surfaces from the walls of the test hole;
3. Fine (from two to 10 millimeter in diameter) gravel (optional);
4. A water supply (50 gallons is generally adequate);
5. A straight board (to serve as fixed reference point for water level measurements);
6. A clock and a ruler (12 inches or longer, engineering scale);
7. An automatic siphon or float valve (optional); and
8. A hole liner consisting of a 14 inch section of slotted pipe or well screen, or a 14 inch length of one-quarter inch hardware cloth or other similar material rolled into a tube (optional). The hole liner shall be no smaller than two inches in diameter less than the test hole.

(b) Percolation tests shall not be conducted in frozen ground or in holes which have been allowed to remain open to the atmosphere for periods greater than three days. The required configuration of the test hole is illustrated in Figure 7 of Appendix A. The following procedure shall be used in preparation of the test hole.

1. Step One: Excavate a test hole having horizontal dimensions of eight to 12 inches at a depth such that the lower six inches of the test hole are contained entirely within the soil horizon or layer of fill material being tested. In order to facilitate access to the lower portion of the hole, the test hole may be excavated from the bottom of a shallow pit provided that the vertical axis of the test hole is a minimum of 14 inches measured from the bottom of the pit to the bottom of the test hole.

2. Step Two: In soil textures other than sands or loamy sands, remove smeared or compacted soil from the sides and bottom of the test hole by inserting the tip of a knife or trowel into the soil surface and gently prying upward and outward. Remove loose soil from the test hole.

3. Step Three: At this point, a one-half inch layer of fine gravel may be placed in the bottom of the hole to protect the soil surface from disturbance or siltation when water is added to the hole. If additional protection is desired, a hole liner as described in (a)8 above may be placed in the hole and the space between the liner and the sides of the hole may be filled with fine gravel.

4. Step Four: Place and secure a straight board horizontally across the top of the test hole, as shown in Figure 7 of Appendix A, to serve as a fixed point for depth of water measurements to be made at appointed time intervals throughout the test.

(c) All soils, except for sandy textured soils which meet the requirements of (d) below, shall be pre-soaked using the following procedure. Any soil which exhibits cracks or fissures between soil aggregates shall be pre-soaked regardless of the texture. Pre-soak as follows:

1. Fill the test hole with water and maintain a minimum depth of 12 inches for a period of four hours by refilling as necessary or by means of an automatic siphon or float valve.

2. At the end of four hours, cease adding water to the hole and allow the hole to drain for a period of from 16 to 24 hours.

(d) In sandy textured soils, including sands, loamy sands and sandy loams, where a rapid percolation rate is anticipated, fill the test hole to a depth of 12 inches and allow to drain completely. Refill the hole to a depth of 12 inches and record the time required for the hole to drain completely. If this time is less than 60 minutes, the test procedure may begin as prescribed in (e) below without further pre-soaking. If water remains in the test hole after 60 minutes, the hole must be pre-soaked as prescribed in (c) above before proceeding with the test.

(e) Immediately following the pre-soak procedure (no more than 28 hours after the start of the pre-soak procedure), the percolation rate shall be determined using the following procedure:

1. Step One: If water remains in the test hole after the completion of the pre-soak period, the test shall be terminated and the percolation rate shall be reported as greater than 60 minutes per inch. If no water remains in the test hole, fill to a depth of seven inches. At a five to 30 minute time interval, depending upon the rate of fall, record the drop in water level to the nearest one-tenth of an inch. Refill the hole at the end of each time interval and repeat this procedure using the same time interval until a constant rate of fall is attained. A constant rate of fall is attained when the difference between the highest and lowest of three consecutive measurements is no greater than two-tenths of an inch.

2. Step Two: Immediately after the completion of Step One, refill the test hole to a depth of seven inches and record the time required for exactly six inches of water to seep away. This time divided by six will be the percolation rate in minutes per inch.

(f) The results of the percolation test shall be interpreted as follows:

1. When the purpose of the test is to determine the design permeability at the level of infiltration, the slowest percolation rate determined within the proposed disposal field shall be used for design purposes. If any of the measured percolation rates are slower than 60 minutes per inch or faster than three minutes per inch the application shall not be approved. A percolation rate may be the result of a single percolation test or the average of several replicate tests, as allowed in N.J.A.C. 7:9A-6.1(e)2.

2. When the result of the test(s) is an average percolation rate slower than 60 minutes per inch, the horizon or substratum in question shall be considered hydraulically restrictive.

3. When the result of the test(s) is an average percolation rate faster than three minutes per inch, the horizon or substratum in question shall be considered excessively coarse.

4. When a seepage pit is proposed, the design percolation rate shall be calculated by adding the products of the percolation rate and the thickness of each individual horizon tested and dividing the result by the total thickness of all the horizons tested. Any horizon with a percolation rate slower than 40 minutes per inch shall be excluded from this computation.

7:9A-6.5 Pit-bailing test

(a) The following equipment is required for performing a pit-bailing test (see Figure 8 in Appendix A):

1. A back-hoe;
2. Wooden or metal stakes, string and a hanging level;
3. A steel measuring tape;
4. A pump (optional);
5. A stop-watch; and
6. A perforated pipe, with a three inch diameter or greater.

(b) The following procedure shall be used for preparation of the test pit:

1. Step One: Excavate a test pit extending into but not below the soil horizon or layer to be tested. The bottom of the pit should be a minimum of 1.5 feet below the observed water level and a minimum of six feet below the proposed level of infiltration. The bottom of the pit should be relatively flat and level. The shape of the pit within the depth interval tested should be approximately square or round. A rectangular or elliptical pit may be used provided that, within the depth interval tested, the length of the long dimension is no more than twice the length of the short dimension. The excavation made for a soil profile pit as prescribed in N.J.A.C. 7:9A-5.2 may be used provided that all the above requirements are met.

2. Step Two: Allow the water level to rise in the pit for a minimum of two hours and until the sides have stabilized. If large volumes of soil have slumped into the pit, this soil must be removed before proceeding with the test. If the sides of the pit continue to slump and cannot be stabilized, the test shall be abandoned. If water is observed seeping into the pit from soil horizons above the zone of saturation in which the test is being conducted, adequate means shall be taken to intercept and divert this water away from the test pit, otherwise the pit-bailing test shall not be used. If, during the excavation of the pit, the water level in the pit rises suddenly after a hydraulically restrictive horizon is penetrated, and continues to rise above the bottom of the hydraulically restrictive horizon, the pit-bailing test shall not be used.

(c) The following procedure shall be used for performance of the pit-bailing test and the calculation of test results:

1. Step One: Establish a fixed reference point for depth to water level measurements which will not be disturbed during removal of water from the pit or which can be temporarily removed and later re-positioned in exactly the same place. One way to establish a removable reference level mark is as follows:

i. Drive stakes firmly into the ground on opposite sides of the test pit, several feet beyond the edge, where they will not be disturbed.

ii. Next, stretch a string with hanging level from stake to stake, over the pit, and adjust the string to make it level.

iii. Finally, secure the string to the stakes and mark or notch the positions on the stakes where the string is attached so that the string may be removed temporarily and later repositioned exactly in its place.

2. Step Two: Measure the distance from the reference level to the bottom of the pit and to the observed water level.

3. Step Three: Lower the water in the pit by at least one foot, by pumping or bailing. If the back-hoe bucket is used to remove water from the pit, it may be necessary to remove the reference level marker prior to bailing and re-position it in its original position prior to beginning step four.

4. Step Four: Choose a time interval, based upon the observed rate of water level rise. At the end of each time interval, measure and record the information indicated in (c)4 i through iii below and repeat these measurements until the water level in the pit has risen a total of one foot or more.

i. Time, in minutes (the time interval, in minutes, between measurements should be chosen to allow the water level to rise by several inches);

ii. Depth of water level below the reference string at the end of each time interval, to the nearest eighth of an inch or one-hundredth of a foot; and

iii. Area of water surface, in square feet. Measure appropriate dimensions of the water surface, depending on the shape of the pit, to permit calculation of the area of the water surface at the time of each water level depth measurement. Entering a soil pit excavated below the water table can be extremely dangerous and should be avoided unless the pit is relatively shallow and the sides of the pit have been stepped and sloped as prescribed in N.J.A.C. 7:9A-5.2(e)3 to eliminate the likelihood of sudden and severe cave-in of the pit. The distance between two opposite edges of the water surface can be measured accurately, without entering the pit, as follows. Place a board on the ground, perpendicular to the side of the pit and extending out over the edge. Using a plumb-bob, position this board so that its end is directly over the edge of the water surface in the pit, below. Position a second board, in the same manner, on the opposite side of the pit. Measure the distance between the ends of the boards to determine the length of the water surface below.

5. Step Five: Determine whether an adequately consistent set of data has been obtained in accordance with (e)5i and ii below.

i. Calculate the permeability for each time interval using the following equation:

$$K_a = (h_{\text{rise}}/t) \times [A_{\text{av}}/2.27 (H^2 - h^2)] \times 60 \text{ min/hr}$$

where:

K_a = permeability, in inches per hour;

h_{rise} = difference in depth to water level at the beginning and end of the time interval, in inches;

t = length of time interval, minutes;

A_{av} = average of water surface area at the beginning of time interval (end of previous time interval) and at the end of the time interval, in square feet;

H = difference between depth to assumed static water level and actual or assumed depth to impermeable stratum, in feet (Depth to impermeable stratum, if unknown, is assumed to be one and one-half times the depth of the pit.); and

h = difference between average depth of water levels at beginning and end of time interval and actual or assumed depth to the impermeable stratum, in feet.

ii. If the calculated values of K_a for successive time intervals show either an increasing or a decreasing trend, repeat Steps Three and Four until consecutive values of K_a are approximately equal.

6. Step Six: Remove as much water as possible from the pit. Continue excavating the pit until an impermeable stratum is encountered or as deep as possible considering the limitations of the excavating equipment used and the nature of the soil conditions encountered. Where no impermeable stratum is encountered, the impermeable stratum shall be assumed to be at the bottom of the excavation.

7. Step Seven: Immediately place upright in the pit a piezometer consisting of a perforated pipe, three inches in diameter or larger, of sufficient length to extend from the bottom of the pit to above the ground surface. Cap and hold the piezometer vertical while backfilling the pit. When the pit is almost completely filled and the piezometer is secure in its position, record the height of the piezometer above the reference level. Finish backfilling the pit and mound soil around the piezometer and over the pit to divert surface water.

8. Step Eight: Return 24 hours or more later and record the depth from the top of the piezometer to the static water level. Correct this depth by subtracting from it the height of the piezometer above the reference level measured in Step Seven.

9. Step Nine: Re-calculate the permeability, K , using the following formula:

$$K = (h_{\text{rise}}/t) \times [A_{\text{av}}/2.27 (H^2-h^2)] \times 60 \text{ min/hr}$$

where:

K = permeability, inches per hour;

The values of h_{rise} , t , and A_{av} are the values recorded for these parameters in the last time interval of Step Four of this subsection;

H = difference between depth to actual corrected static water level and actual or assumed depth to impermeable stratum, recorded in Steps Six and Eight, in feet; and

h = difference between the average depth of water levels at the beginning and end of the last time interval recorded in Step Four and the actual or assumed depth to the impermeable stratum recorded in Step Six, in feet.

(d) When the permeability calculated in Step Eight of (c) above is slower than 0.2 inch per hour, the horizon(s) being tested shall be considered a hydraulically restrictive horizon and shall not be considered an acceptable zone of wastewater disposal.

(e) When piezometers are used for conducting this test, they shall be installed and removed in accordance with the Department's procedures pursuant to N.J.S.A. 58:4A-4.1 et seq.

7:9A-6.6 Piezometer test

(a) The following equipment is required for the piezometer test:

1. A screw type soil auger, minimum of one inch in diameter, with extensions;
2. A piezometer tube consisting of a metal pipe beveled on the outside lower edge, with an inside diameter about one-sixteenth of an inch larger than the diameter of the soil auger;
3. A maul or hammer, to drive pipe into the ground;
4. A pump with tubing, to evacuate water from piezometer tube;
5. A stop watch;
6. A means for accurately measuring the water level within the piezometer tube as a function of time, which may consist of one of the following:
 - i. A light-weight rod with measuring scale mounted on a cylindrical float with a diameter one-quarter inch or more smaller than the inside diameter of the piezometer tube;
 - ii. An electric probe consisting of a thin wire embedded in and protruding from the tapered end of a wooden rod, graduated in inches, and connected in series to a limiting resistor, a millimeter and a 33-volt hearing-aid battery, the opposite terminal of which is connected to the piezometer tube; or
 - iii. For depths greater than six feet, an electric sounder or the "wetted tape" method should be used.

(b) The following procedure shall be used for the piezometer test:

1. Step One: Remove any sod, vegetation or leaf litter from the ground surface where the test hole will be excavated. The test hole may be excavated from the existing ground surface or from the bottom of a larger excavation or soil profile pit.
2. Install the piezometer in accordance with Step Two A and Two B outlined in (b)2i and ii below or Alternate Step Two outlined in (b)2iii below.
 - i. Step Two A: Using the soil auger, drill the test hole down to a depth of six inches. Remove the auger and drive the piezometer tube into the hole to a depth of five inches. Re-insert the soil auger through the piezometer tube and into the test hole and drill down six inches further. Remove the soil auger, drive the piezometer tube six inches deeper, re-insert the auger and drill six inches deeper, repeating this procedure until the test hole reaches the top of the soil horizon or zone within a soil horizon to be tested.
 - ii. Step Two B: Using the soil auger, extend the test hole exactly four inches below the bottom of the

piezometer tube (see Figure 9 of Appendix A). In coarse-textured soils lacking cohesion, where the unlined cavity at the bottom of the test hole may be unstable, use a piezometer tube with closely spaced perforations in the lower four inches of its length and drive the tube down to the bottom of the test hole.

iii. Alternate Step Two: Power equipment may be used in lieu of the hand auger to drill the test hole and install the piezometer casing provided that the casing fits tightly into the hole or the installation is sealed with bentonite so that leakage does not occur around the outside of the casing and provided that a suitable unlined cavity is provided at the bottom of the bore hole as required in Step Two B above.

3. Step Three: Allow the lower portion of the test hole to fill with ground water and pump the water out one or more times to minimize the effect of soil puddling and to flush the soil pores in the unlined portion of the test hole.

4. Step Four: Allow the water level to rise within the piezometer until the water level becomes relatively stable. Note the approximate rate of rise and record the static water level using the top of the piezometer tube as a reference point.

5. Step Five: Pump most of the water out of the piezometer tube. Record the time and the depth of the water level below the top of the tube. After an appropriate interval of time, record the new depth of the water level. Choose the length of the time interval based upon the rate of rise observed in Step Four so that the difference in water levels at the beginning and end of the time interval will be large enough to permit an accurate measurement, but do not allow the water level to rise to within eight inches of the static level determined in Step Four.

6. Step Six: Repeat Step Five of this subsection, lowering the water level to approximately the same depth and using the same time interval, until consistent results are obtained.

7. Step Seven: Allow the water level in the piezometer tube to rise and, a minimum of 24 hours later, record the depth of the water table for use in the calculation of permeability.

(c) The permeability of the soil horizon tested shall be determined as follows:

1. Step One: Determine the value of the A-parameter from Figure 10 of Appendix A based upon D, the diameter of the soil auger (or drill bit).

2. Step Two: Calculate the permeability, K, in inches per hour, using the following formula:

$K = 60 \text{ min/hr} \times (3.14R^2)/At \times \ln(d_1 - D_{\text{stat}}/d_2 - D_{\text{stat}})$ where:

K = the permeability of the soil horizon tested, in inches per hour;

R = the inside radius of the piezometer tube, in inches;

\ln = the natural logarithm;

D_{stat} = the depth of the static water level below the top of the piezometer tube determined in Step Seven, in inches;

d_1 = depth of the water level below the top of the piezometer tube at the beginning of the last time interval, in inches;

d_2 = depth of the water level below the top of the piezometer tube at the end of the last time interval, in inches;

t = length of time interval, in minutes; and

A = value determined in Step One above, in inches.

(d) When the permeability calculated in (c)2 above is less than 0.2 inch per hour, the horizon or substratum in question shall be considered hydraulically restrictive and shall not be considered an acceptable zone of wastewater disposal.

(e) When piezometers are used for conducting this test, they shall be installed and removed in accordance with the Department's procedures pursuant to N.J.S.A. 58:4A-4.1 et seq.

7:9A-6.7 Basin flooding test

(a) The following equipment is required for basin flooding test:

1. Excavating equipment capable of producing a test basin as prescribed in (b) below;

2. A water supply (minimum of 375 gallons per basin filling); and

3. A means for accurately measuring the water level within the basin as required in (c) below.

(b) A test basin meeting the following requirements shall be excavated within or immediately adjacent to the proposed disposal field.

1. The bottom of the test basin shall be at a depth between six and eight feet below the bottom of the proposed level of infiltration.

2. The bottom area of the basin shall be a minimum of 50 square feet.

3. A soil profile pit excavated as prescribed in N.J.A.C. 7:9A-5.2 may be utilized for this test provided that the requirements of (b)1 and 2 above are satisfied.

4. The bottom of the basin should be made as level as possible so that high areas of rock do not project above the water level when the basin is flooded as prescribed in (c) below.

5. If ground water is observed within the test basin, the basin flooding test shall not be used.

(c) The following test procedure shall be used for the basin flooding test:

1. Step One: Fill the test basin with exactly 12 inches of water and record the time. Allow the basin to drain completely. If the time required for the basin to drain completely is greater than 24 hours, the test shall be terminated and the limiting zone in question shall be considered to be a massive rock substratum.

2. Step Two: If the basin drains completely within 24 hours after the first flooding, immediately refill the basin to a depth of 12 inches and record the time. If the basin drains completely within 24 hours of the second filling, the limiting zone in question shall be considered to be fractured rock substratum. If water remains in the basin after 24 hours the limiting zone in question shall be considered to be a massive rock substratum.

(d) Due to the potential safety hazards which are posed by the excavation of a large test basin such as that required for this test, adequate safety measures shall be taken including the use of stepped and sloped sidewalls as shown in Figure 2 of Appendix A to permit safe access to the test basin during the test procedure as well as the use of warning signs or a fence to limit access to the basin by the public during periods when the basin is left unattended, or both.

(e) The basin flooding test shall not be conducted in rock strata which have been blasted with explosives.

SUBCHAPTER 7. GENERAL DESIGN AND CONSTRUCTION REQUIREMENTS

7:9A-7.1 Design requirements

(a) A professional engineer who is licensed in the State of New Jersey shall design all individual subsurface sewage disposal systems.

(b) The engineer shall take into consideration slope, surface drainage, soil characteristics, the presence and depth of limiting zones within the soil, soil permeability, type of wastes and the expected volume of sanitary sewage in the design of all individual subsurface sewage disposal systems.

(c) Individual subsurface sewage disposal systems shall not be designed in a manner that will permit a direct discharge of sanitary sewage or septic tank effluent onto the surface of the ground, into a subsurface drain, or into any water course.

7:9A-7.2 Construction

(a) The system and all its component parts shall be constructed and installed to conform in all details to the requirements set forth in this chapter and to the engineering design which has been approved by the administrative au-

thority. Departures from the approved design which become necessary due to circumstances which arise during construction and installation shall be approved by the design engineer and the administrative authority in accordance with N.J.A.C. 7:9A-3.7 and shall meet or exceed the requirements of this chapter.

(b) Construction and installation shall be performed in such a manner that the capacity of the soil or fill material to adequately absorb or purify the septic tank effluent is not adversely affected.

7:9A-7.3 Type of wastes

(a) The system(s) shall be designed to receive all sanitary sewage from the building served except in the following cases:

1. Separate systems may be designed to receive only greywater, or only blackwater, as allowed in N.J.A.C. 7:9A-7.5.

2. Laundry wastes may be discharged into a seepage pit when approved by the administrative authority as a means of reducing hydraulic loading on an existing disposal field which has been malfunctioning. (b) Drainage from basement floors, footings or roofs shall not enter the individual subsurface sewage disposal system and shall be diverted away from the area of the disposal field. Backwash from water softeners shall not be disposed of within the subsurface sewage disposal system.

(c) Discharge of industrial wastes onto the land, into the soil, or into the ground water is prohibited. The administrative authority shall not approve any system serving any establishment engaged in activities such as photo-processing, dry-cleaning, printing, furniture stripping and refinishing, manufacturing, automobile painting, or any other process or activity which may result in discharge of industrial wastes into the system, without prior approval from the Department. Where doubt exists as to whether or not a waste generated by a particular facility may be considered as an industrial waste, the administrative authority shall instruct the applicant to contact the Department for a determination of whether or not a NJPDES permit will be required.

(d) The administrative authority shall report to the Department any discharge of industrial wastes into an individual subsurface sewage disposal system. Use of sewage system cleaners which contain restricted chemical materials shall be considered to be a discharge of industrial wastes and is prohibited.

7:9A-7.4 Volume of sanitary sewage

(a) Each component of the individual subsurface sewage disposal system shall be designed and constructed to adequately treat and dispose of the expected volume of sanitary sewage to be discharged from the premises to be served. The expected volume of sanitary sewage from private residential sources shall be determined based on the criteria set forth in (b) below. The expected volume of sanitary sewage from commercial or institutional establishments shall be determined based on the criteria set forth in (c) below.

(b) The criteria for estimating the volume of sanitary sewage from private residential sources shall be as follows:

Volume, first bedroom	200 gallons per day ("gal/day")
Volume, each additional bedroom	150 gal/day
Minimum volume per dwelling unit	350 gal/day
Minimum volume per apartment	350 gal/day

2. The minimum volume for a dwelling unit shall be reduced to 200 gallons per day in the case of deed restricted senior citizen communities or mobile home parks with dwelling units less than 500 square feet in size.

(c) The volume of sanitary sewage from commercial or institutional establishments shall be based upon the type and size of the facility and the maximum expected number of persons that may be served during any single day of operation. The volume shall be estimated as follows:

1. Depending upon the method of estimation selected from (d) below, multiply the number of gallons per person (user) by the maximum expected number of persons per day, or multiply the number of gallons per facility (unit) per day by the number of facilities (units) present or proposed.

2. Estimate the maximum number of employees which may be present during a single day of operation and add an additional 15 gallons per employee per each additional eight hour shift, except in the case of (d)24, (d)32, (d)38 and (d)40 below.

(d) The criteria listed below are minimum standards for average facilities of the categories listed. In cases where a facility does not fall within any of the categories, the administrative authority may approve the use of other documented criteria, such as actual water data for the facility or other similar facilities, provided that the value used for design is at least 50 percent greater than the average daily volume of sewage.

Type of Establishment	Method of Estimation (gallon per user or gallon per unit per day)
1. Airport	5 gal/passenger
2. Assembly Hall	3 gal/seat/day
3. Auto Service Station	10 gal/car served
4. Bar	5 gal/patron
5. Bathroom with shower without shower	25 gal/person 10 gal/person
6. Beach Club	25 gal/person
7. Beauty parlors and salons	120 gal/day/sink
8. Boarding House, Meals	75 gal/guest ² 15 gal/non-resident boarder
9. Bowling Alley, no food with food, add	125 gal/lane/day 5 gal/patron
10. Bus Stop Rest Area	5 gal/passenger
11. Cafeteria	5 gal/customer
12. Camp, Cottage (barracks type)	65 gal/person
13. Camp, Day, no meals	20 gal/person
14. Camp, Resort	100 gal/site/day ²
15. Camp, Trailer with toilets, add	100 gal/site/day ² 10 gal/person/day
16. Church, with or without kitchen	3 gal/seat/day
17. Cocktail Lounge	5 gal/customer
18. Coffee Shop	5 gal/customer
19. Comfort Station/Picnic Grounds, with toilets	10 gal/person

Type of Establishment	Method of Estimation (gallon per user or gallon per unit per day)
with toilets and showers	15 gal/person
20. Cottages	100 gal/person ² minimum 350 gal/dwelling unit/day
21. Country Club	60 gal/member/day 25 gal/non-member
22. Dining Hall	5 gal/customer
23. Dormitory, Bunkhouse	40 gal/bed/day
24. Factory/Industrial Building with showers, add	15 gal/employee per eight hour shift 15 gal/employee per eight hour shift
25. Hospital, Medical	250 gal/bed/day
26. Hospital, Mental	150 gal/bed/day
27. Hotels	130 gal/room/day
28. Institution, Other than hospi- tal	150 gal/bed/day
29. Laundry, Self-service	50 gal/wash
30. Motel	130 gal/room/day
31. Nursing/Rest Home	150 gal/bed/day
32. Office Buildings	15 gal/employee per eight hour shift or 0.125 gal/ft ² , which- ever is greatest
33. Prison	150 gal/inmate/day
34. Restaurant sanitary wastes only kitchen wastes, add	5 gal/patron 5 gal/patron
35. Rooming House, no meals	65 gal/bed/day
36. School, Boarding	100 gal/student/day
37. School, Day No cafeteria or showers Cafeteria only Cafeteria and showers Cafeteria, showers and labo- ratories	10 gal/student/day 15 gal/student/day 20 gal/student/day 25 gal/student/day
38. Shopping Center	0.125 gal/square ft./day ¹
39. Stadium	3 gal/seat/day
40. Store	0.125 gal/square ft./day ¹
41. Swimming Pool	10 gal/person
42. Theater, Indoor	3 gal/seat/day
43. Theater, Outdoor	10 gal/parking space
44. Visitor Center	5 gal/visitor

¹ Volume of sanitary sewage for employees included within method of estimation indicated.

² If laundry wastes are anticipated, increase the estimated flow by 50 percent.

Amended by R.1994 d.469, effective September 19, 1994.

See: 26 N.J.R. 2715(a), 26 N.J.R. 3829(a).

7:9A-7.5 Separate disposal of greywater and blackwater

A greywater system may be approved by the administrative authority provided that all of the requirements of these standards are satisfied and provided that an acceptable means for disposal of the blackwater from the building served is indicated in the system design. When the blackwater from the building served by a greywater system is to be disposed of into a waterless toilet, a variance from the Uniform Construction Code, Plumbing sub-code, N.J.A.C. 5:23-3.5, must be obtained by the applicant prior to approval of the greywater system by the administrative authority and the volume of sanitary sewage to be used in the design of the greywater system shall be determined as prescribed in N.J.A.C. 7:9A-7.4. When the blackwater from the building served by a greywater system is to be disposed of into a separate subsurface sewage disposal system, the blackwater system shall meet all the requirements of this chapter and the volume of sanitary sewage used in the design of both the greywater system and the blackwater system shall be a minimum of 75 percent of the volume of sanitary sewage determined as prescribed in N.J.A.C. 7:9A-7.4.

7:9A-7.6 Type of system

Each system approved by the administrative authority pursuant to this chapter shall consist of a septic tank which discharges effluent through a gravity flow, gravity dosing or pressure dosing network to a disposal field as hereafter described. Seepage pits shall not be approved for new installations except in the case of a greywater system as provided by in N.J.A.C. 7:9A-7.5. Installation of a seepage pit may be approved as an alteration for an existing system subject to the requirements of N.J.A.C. 7:9A-3.3.

7:9A-7.7 Building sewer

The building sewer shall be designed and constructed in accordance with the provisions of the State Uniform Construction Code, N.J.A.C. 5:23, adopted pursuant to the Uniform Construction Code Act, N.J.S.A. 52:27D-119 et seq.

SUBCHAPTER 8. PRETREATMENT UNITS
7:9A-8.1 Grease traps

(a) Restaurants, cafeterias, institutional kitchens and other installations discharging large quantities of grease shall use a grease trap. A garbage grinder shall not be used when a grease trap is required.

(b) The grease trap shall be installed in a separate line serving that part of the plumbing system into which the grease will be discharged. The grease trap shall be located close to the source of the wastewater, where the wastewater is still hot, to facilitate separation. Grease traps shall be located, designed and constructed in a manner that will permit easy access and cleaning.

(c) The following equation shall be used to determine the minimum size required for grease traps serving restaurants:

$$Q = (D) \times (HR/2) \times (12.5) \times (LF), \text{ where:}$$

Q = size of grease trap in gallons;

D = number of seats in dining area;

HR = number of hours open per day; and

LF = loading factor depending on restaurant location:

1.25 for interstate freeways;

1.0 for other freeways;

1.0 for recreation areas;

0.8 for main highways;

0.5 for other highways.

(d) The following equation shall be used to determine the minimum size required for grease traps serving cafeterias and institutional kitchens:

$$Q = (M) \times (11.25) \times (LF), \text{ where:}$$

Q = size of grease trap, gallons;

M = total number of meals served per day; and

LF = loading factor depending on type of facilities present:

1.0 with dishwashing;

0.5 without dishwashing.

(e) In no case shall a grease trap serving a restaurant, cafeteria or institutional kitchen be smaller than 750 gallons in capacity.

(f) The minimum requirements for construction, materials and foundations of grease traps shall be the same as those required for septic tanks, as prescribed in N.J.A.C. 7:9A-8.2.

(g) The inlet and outlet of the grease trap shall be provided with "T" baffles extending to a depth of 12 inches above the tank floor and well above the liquid level.

(h) To facilitate maintenance, manholes extending to finished grade shall be provided. Covers shall be of gas-tight construction and shall be designed to withstand expected loads and prevent access by children.

7:9A-8.2 Septic tanks

(a) The use of a septic tank shall be required for all subsurface wastewater disposal systems. Use of an aerobic treatment unit or any other device in lieu of a septic tank shall not be approved by the administrative authority without prior approval by the Department. An aerobic treatment unit may precede the septic tank if the septic tank and all other components of the subsurface wastewater disposal system are sized in strict conformance with this chapter and:

1. For batch processing aerobic treatment units the septic tank precedes in series the aerobic treatment unit; or,

2. For gravity flow aerobic treatment units the septic tank follows in series the aerobic treatment unit.

(b) The minimum capacity of the septic tank shall be determined in accordance with the following criteria:

1. When serving single family dwelling units, septic tanks shall have the minimum capacity of 250 gallons per bedroom. Expansion attics shall be considered additional bedrooms. In no case shall the capacity be less than 1000 gallons.

2. When serving installations other than single family dwelling units, the minimum capacity shall be 1.5 times (150 percent) the volume of sanitary sewage, Q, when Q, determined as prescribed in N.J.A.C. 7:9A-7.4, is less than 1,500 gallons per day. When Q is greater than 1,500 gallons per day, the minimum capacity in gallons shall be 1,125 plus 0.75Q. In no case shall the capacity be less than 1000 gallons.

3. Two or more septic tanks may be connected in series in order to obtain the minimum required liquid capacity providing that each tank is at least as large as the succeeding tank. When a multiple compartment tank is used, the requirements of (d)3 below shall be satisfied.

(c) When domestic garbage grinder units are installed or proposed, a multiple compartment septic tank is required and the liquid capacity of the septic tank(s), exclusive of air space, shall be at least 50 percent greater than the minimum capacity required in (b)1 above.

(d) Multiple compartment septic tanks shall be required for institutional and commercial installations where the daily volume of sewage determined as prescribed in N.J.A.C. 7:9A-7.4 is greater than 1000 gallons. When multiple compartment tanks are used the following shall be required:

1. The total capacity of multiple compartment tanks shall not be less than 1000 gallons. The first compartment shall have a liquid capacity of two-thirds the total required liquid capacity determined as prescribed in (b) above.

2. Not more than two compartments shall be provided in tanks having liquid capacities of less than 1250 gallons. Tanks having liquid capacities of over 1250 gallons may be provided with more than two compartments.

3. Multiple compartments may be provided by partitions within a single tank as shown in Figure 11 of Appendix A, or by connecting individual tanks in series. When a single partitioned tank is used, vent holes shall be provided near the top of each partition to allow free exchange of evolved gases between compartments and the two compartments shall be connected by means of a pipe tee, baffle or septic solids retainer, as shown in Figure 11.

(e) Septic tanks shall be designed and constructed according to the following requirements:

1. Septic tanks shall be water-tight and constructed of sound and durable materials which are resistant to corrosion, decay, frost damage or to cracking or buckling due to settlement or backfilling. All joints below the liquid level of the tank or below the seasonally high water table shall be provided with a permanent water-tight seal.

2. Covers shall be designed and constructed so as not to be damaged by any load which is likely to be placed on them. Precast slabs used as covers shall be water-tight, a minimum of three inches in thickness and adequately reinforced.

3. The walls and base of poured-in-place concrete tanks shall not be less than six inches in thickness. The sides and bottom of precast concrete tanks shall be a minimum of three inches in thickness and shall be adequately reinforced.

4. Concrete used in the construction of septic tanks shall conform to the American Concrete Institute (ACI) standards for frost resistance (ACI 318-16-4.5.1) and water-tightness (ACI 318-16-4.5.2). In the case of built-in-place tanks, certification that these standards have been met shall be provided by the design engineer and the certification shall be signed, sealed and attached to the approved engineering design. In the case of precast tanks, certification shall be provided by the manufacturer and the certification displayed on the tank.

5. All inside concrete surfaces shall be sealed with two coatings of an appropriate inert coating to minimize corrosion. Coating of pre-cast tanks shall be applied by the manufacturer prior to delivery to the job site.

6. The base of poured-in-place tanks shall be cast in one piece and shall extend beyond the side and end walls of the tank. Such tanks shall not be emplaced until 48 hours after the base has been poured.

7. Pre-fabricated polyethylene septic tanks shall conform with the standards for materials, wall thickness, fastening of fittings and maximum deformation under load as prescribed by the Canadian Standards Association in CSA Standard CAN3-B66-M79.

8. Pre-fabricated fiberglass septic tanks shall conform to ASTM Standard D4021.

(f) A pre-fabricated septic tank constructed of any material which may be floated or shifted by water or ground cave-in shall be filled with water immediately after it is set in its proper position. When a septic tank is installed below or partially below the level of the seasonally high water table, the design engineer shall show by means of appropriate calculations that the tank is of sufficient weight or will be otherwise secured or anchored so that it will not shift or float if emptied during the time of seasonally high groundwater. Perforating or otherwise damaging the water-tight integrity of a septic tank for the purpose of installation below the water table is prohibited.

(g) Septic tanks shall be placed upon a firm and stable foundation so that the potential for uneven settlement or shifting is minimized. Tanks shall be constructed or installed directly on undisturbed natural soil. If the excavation is dug too deep, it shall be backfilled to the proper elevation with sand. When the tank must be constructed or installed on a layer of fill material greater than one foot in thickness, the fill shall be properly emplaced and compacted as prescribed in N.J.A.C. 7:9A-10.4(f)3.

(h) Metal septic tanks are prohibited. Septic tanks may be constructed of the following materials:

1. Poured-in-place concrete;
2. Precast reinforced concrete;
3. Fiberglass;
4. Polyethylene; or
5. Other materials as approved by the Department.

(i) Septic tanks shall conform to the following specifications:

1. The depth below the liquid level of the tank shall not be less than 36 inches or more than 72 inches.

2. Inlets and outlets shall be arranged so that all flow is directed along the longest horizontal dimension of the tank.

3. Tanks which are rectangular in cross-section shall have an inside length at least twice the inside width. The inside length, measured from the inlet side to the outlet side, shall not be less than 72 inches. The inside width of the tank shall not be less than 36 inches.

4. Upright cylindrical tanks shall have a minimum diameter of 52 inches. Horizontal cylindrical tanks shall have a minimum length of 72 inches and a minimum width at the liquid level of 36 inches.

(j) Inlets and outlets of septic tanks shall conform to the following specifications:

1. Inlet and outlet connections of each tank or compartment shall be arranged so as to obtain effective retention of scum and sludge and shall be fastened with and constructed of, or coated with, materials which are resistant to corrosion by sulfuric acid. Where pipe tees are used, the tees shall be sanitary tees and shall be installed in a manner that will provide a lasting watertight seal between the tee and the wall of the tank. For this purpose, a manufactured water-proof pipe coupling which is incorporated into the wall of the tank may be used, or an expanding grout which will adhere both to the tee and to the body of the tank where the tee is installed.

2. A baffle or a pipe tee, not less than four inches in diameter, is required at the inlet of the tank. The bottom of the baffle or the bottom of the vertical leg of the tee shall extend below the liquid level a distance equal to 25 to 33 percent of the liquid depth. The invert elevation of the inlet shall not be less than two inches higher than the invert elevation of the tank outlet or the outlet of the first compartment. The inverts of the inlets of subsequent compartments shall be a minimum of one inch higher than their outlets.

3. Outlet connections of the tank or each compartment thereof shall be provided with a tee not less than four inches in diameter or a durable baffle equivalent in size. They shall be permanently fastened in place with the bottom opening extending below the liquid level by a distance equal to 25 to 40 percent of the total liquid depth. Outlet baffles or tees shall be provided with a gas deflection baffle installed as shown in Figure 12 of Appendix A. In lieu of a baffle or tee connection, an alternative device such as a septic solids retainer may be used provided that this device bears the seal of the National Sanitation Foundation ("NSF") certifying that the device has been approved by NSF for the specific use proposed and provided that the installation conforms to the manufacturer's recommendations. Where a septic solids retainer is used, a gas deflection baffle is not required.

(k) The space between the liquid surface and the top of the outlet tee or baffle shall not be less than 15 percent of the total liquid depth.

(l) Access openings for septic tanks shall meet the following requirements:

1. Each septic tank or each compartment of a multiple compartment tank shall be provided with at least one access opening which shall be a manhole a minimum of 24 inches square or 24 inches in diameter.

2. All manholes at a minimum shall be extended to within six inches of finished grade by means of a riser fitted with a removable watertight cover. Where manholes are extended flush with finished grade, covers shall be bolted or locked to prevent access by children and shall be of cast iron when a concrete riser is used. When manholes are not extended to finished grade, covers shall be constructed of precast reinforced concrete, fiberglass, polyethylene or other materials as specified by a licensed professional engineer and approved by the administrative authority. The location of the manhole shall be marked on the ground surface by means of a permanent, non-corrosive marker a minimum of three inches in diameter.

3. An inspection port extending to finished grade shall be provided over each tank or compartment inlet and outlet which is not directly below a manhole except for those outlets where a septic solids retainer is used. Inspection ports shall extend to finished grade, shall be constructed of four inch cast iron or Polyvinyl Chloride (PVC), and shall have a locked or bolted cap.

4. Manhole risers and inspection ports on fiberglass or polyethylene tanks shall be constructed of the same material as the tank.

(m) Backfill around septic tanks shall be free of large stones, roots or foreign objects, shall be placed in thin layers, not to exceed eight inches, and shall be thoroughly tamped in a manner that will not produce undue strain on the tank. In the case of pre-fabricated plastic or fiberglass tanks, backfill shall be no thicker than the maximum depth recommended by the manufacturer.

Amended by R.1993 d.294, effective June 21, 1993.
See: 24 N.J.R. 1987(a), 25 N.J.R. 2704(b).

SUBCHAPTER 9. EFFLUENT DISTRIBUTION NETWORKS

7:9A-9.1 General requirements for effluent distribution

(a) Discharge of effluent from the septic tank or grease trap to the disposal field and distribution of effluent within the disposal field shall be accomplished by one of the following methods:

1. The gravity flow method whereby the pretreatment unit discharges directly to a single distribution lateral, an inter-connected network of distribution laterals or to a distribution box discharging to two or more individual distribution laterals;

2. The gravity dosing method whereby the pretreatment unit discharges to a dosing tank with a pump or siphon which in turn discharges to a single distribution lateral, an inter-connected network of distribution laterals or to a distribution box discharging to two or more individual distribution laterals; or

3. The pressure dosing method whereby the pretreatment unit discharges to a dosing tank with a pump or siphon which in turn discharges to an inter-connected network of distribution laterals designed to discharge effluent under pressure.

(b) Each lateral in the distribution network shall receive an equal hydraulic loading. The use of serial distribution is prohibited.

(c) The use of gravity flow is restricted to those cases where less than 600 linear feet of distribution laterals are used and where the relative locations and elevations of the system components will allow gravity flow from the building sewer to the pretreatment unit and on through the distribution network.

(d) Alternating siphons or pumps may be used to alternately dose and rest two or more disposal fields provided that no field or portion of a field receives more than the maximum daily hydraulic loading rate allowed in N.J.A.C. 7:9A-10.2. Soils with a permeability faster than six inches per hour or a percolation rate faster than 15 minutes per inch shall not be rested for periods longer than one day unless pressure distribution is used and shall not receive more than 25 percent of the maximum allowed daily hydraulic loading in a single dose.

7:9A-9.2 Dosing tanks

(a) A dosing tank using a siphon or pump is required for systems using gravity or pressure dosing and shall meet the requirements of (b) through (f) below.

(b) The minimum capacity of dosing tanks using pumps shall be determined as follows:

1. Dosing tanks using pumps shall have sufficient capacity to distribute septic tank effluent equally to all parts of the disposal field during each dosing cycle and to provide adequate reserve storage capacity in the event of a pump malfunction. The total liquid capacity shall be great enough to accommodate the minimum required dose volume determined as prescribed in (b)2 below, plus the minimum required reserve storage capacity determined as prescribed in (b)3 below. Additional volume must be provided above the pumping level to accommodate the volume of water displaced by the pump and controls as well as any quantity of effluent which will drain back into the dosing tank when the pump shuts off at the end of a dosing cycle. Additional volume must be provided below the pumping level so that the pump may be placed on a pedestal, above the dosing tank bottom, to prevent the pump from drawing in air or whatever solids may accumulate in the bottom of the dosing tank.

2. The dose volume shall be determined based upon the soil permeability or percolation rate, daily volume of sewage (Q) and the total internal volume of the distribution network (V), as shown below. In the case of pressure dosing systems, the volume of the distribution network, V, shall include the volume of the delivery pipe, the manifold and the laterals.

Soil Permeability (in/hr)	Percolation Rate (min/in)	Required Dose Volume Gravity Dosing	Required Dose Volume Pressure Dosing
6-20	3-15	minimum of 75 percent V, ¹ maximum of 25 percent Q	minimum of 10V ² maximum of 25 percent Q
0.2-6	15-60	minimum of 75 percent V maximum of 100 percent Q	minimum of 10V maximum of 100 percent Q

¹ In cases where 75 percent V is larger than 25 percent Q, the 25 percent Q maximum rather than the 75 percent minimum shall be observed.

² In cases where 10V is larger than 25 percent Q, the 25 percent Q maximum rather than the 10V minimum shall be observed.

3. Reserve capacity is the inside volume of the dosing tank which lies between the level at which the high-water alarm switch is set and the invert elevation of the tank inlet, as shown in Figure 13 of Appendix A. A minimum reserve capacity equal to the daily volume of sewage shall be required except where a stand-by pump is provided which is equivalent in performance capacity to the primary pump and which will switch on automatically in the event that the primary pump malfunctions.

(c) The capacity of dosing tanks using siphons shall be adequate to provide the required dose volume determined as prescribed in (b)2 above. No reserve capacity is required when a siphon is used.

(d) All dosing tanks shall meet the following requirements regardless of whether a pump or siphon is used.

1. The requirements for the construction of dosing tanks shall be the same as those prescribed for septic tanks in N.J.A.C. 7:9A-8.2(e). Dosing tanks may be constructed as a separate unit or may share a common wall with the pretreatment unit.

2. Materials used for the construction of dosing tanks shall be the same as those allowed for septic tanks as prescribed in N.J.A.C. 7:9A-8.2(h).

3. Dosing tanks shall be constructed in a manner that will permit venting of the disposal area.

4. Installation requirements for pre-fabricated dosing tanks shall be the same as those for septic tanks, as prescribed in N.J.A.C. 7:9A-8.2(f).

5. Dosing tanks shall be placed on a firm and stable foundation so that the potential for differential settling or shifting is minimized.

6. Inlets shall be above the highest water level attained when the entire reserve capacity is full. Outlets for dosing tanks using siphons shall conform with the manufacturer's recommendations.

7. Dosing tanks shall be readily accessible for service and repair. A removable watertight cover or a manhole with a removable watertight cover shall be provided. Manholes shall be a minimum of 24 inches in diameter or 24 inches square and shall be located directly over the pump or siphon. The top of the tank or manhole riser, at a minimum, shall be extended to within six inches of finished grade and be equipped with a watertight cover. Where manholes are extended flush with finished grade, the cover shall be bolted or locked to prevent access by children and shall be of cast iron when a concrete riser is used. When the top of the tank or manhole is not extended to finished grade, covers shall be constructed of precast reinforced concrete, fiberglass, polyethylene or other materials as specified by a licensed professional engineer and approved by the administrative authority. The location of the manhole shall be marked on the ground surface by means of a permanent, non-corrosive marker a minimum of three inches in diameter.

8. Requirements for backfilling around dosing tanks shall be the same as for septic tanks, as prescribed in N.J.A.C. 7:9A-8.2(m).

(e) Dosing may be accomplished by means of an automatic siphon when the low water level in the dosing tank is at a higher elevation than the invert of the highest distribution lateral. When a siphon is used the following requirements shall be met:

1. Siphons shall be constructed of durable materials not subject to corrosion by acid or alkali.

2. Extreme care shall be utilized in the installation of siphons. The installation shall conform exactly and in all details to the manufacturer's recommendations and specifications.

3. The horizontal dimensions of the dosing tank shall be adjusted so that the volume obtained by multiplying the manufacturer's rated siphon drawing depth by the internal horizontal area of the tank will be equal to the required dose volume determined as prescribed in (b)2 above.

4. When installation is complete, the siphon shall be primed by filling it with water at which time the siphon shall be checked for leaks as evidenced by air bubbles rising from the bell casing or piping. Any leaks shall be repaired before final approval is given.

5. In gravity dosing systems, when the delivery pipe between the dosing tank and the distribution box or distribution network is long, the siphon invert shall be set at an elevation sufficiently higher than the invert of the highest distribution lateral to compensate for any head losses due to friction in the connecting pipe. Friction head shall be determined using Figure 16 of Appendix A.

6. In pressure dosing systems, the invert of the siphon shall be set higher than the invert of the distribution laterals by a distance equal to the total operating head determined as prescribed in N.J.A.C. 7:9A-9.7(a)ii.

7. For facilities from which large quantities of septic tank effluent may be discharged at one time, the design engineer shall make certain that the siphon discharge rate will not be exceeded by the maximum expected rate of inflow at time of peak flow.

8. Each dosing tank shall be equipped with a cycle counter activated by a weighted float or mercury switch to facilitate monitoring of siphon performance.

9. Dosing tanks using siphons shall be equipped with an overflow to the distribution box or distribution network and a high-water alarm meeting the requirements of (f)7iii below. The invert of the overflow shall be just above the level of the high-water alarm switch which shall be several inches above the normal high-water level of the dosing tank.

(f) Dosing may be accomplished by means of a pump when either gravity dosing or pressure dosing is used. Duplicate pumps may be required by the administrative authority. The following requirements shall be met:

1. The pump must be rated by the manufacturer to handle septic tank effluent and all equipment must be listed and identified for the intended use as determined by the design.

2. Pumps used for gravity dosing systems must be rated by the manufacturer, as indicated by the manufacturer's pump performance curve, to be capable of delivering the total required dose volume within a period of 15 minutes or less when working against a total dynamic head equal to the total design operating head. For the purpose of making this determination, the total design operating head shall be considered as the sum of the

elevation head and the friction head calculated as prescribed in N.J.A.C. 7:9A-9.7(a)7.

3. Selection of an adequate pump for pressure dosing is part of the design procedure for pressure dosing systems and shall be performed in conformance with N.J.A.C. 7:9A-9.7(a).

4. Pumps shall be set on a pedestal so that the intake is elevated several inches above the bottom of the dosing tank.

5. Easy or "quick-disconnect" couplings shall be used to facilitate removal of the pump for servicing.

6. For facilities from which large quantities of septic tank effluent may be discharged at one time, the design engineer shall make certain that the pump discharge rate will not be exceeded by the maximum expected rate of inflow at times of peak flow.

7. The operation of the pump shall be controlled by means of automatic switches which are activated by the rising and falling level of effluent in the dosing tank. Such switches shall meet the following requirements:

i. Switches shall be able to withstand the humid and corrosive atmosphere in the dosing tank. Mercury or weighted float type switches are suitable for this purpose. Pressure-diaphragm type switches are prohibited.

ii. The pump-on and pump-off switches shall be set at appropriate levels to provide a dose volume as required in N.J.A.C. 7:9A-9.2(a)2. The pump-off switch shall be set six inches above the pump intake. The pump-on switch shall be set at a distance, d , above the pump-off switch, which is calculated by means of the following formula:

$d, \text{ in} = (V_d + V_{cp} + V_{pd}) \times (1 \text{ ft}^3/7.48 \text{ gal}) \times (12 \text{ in}/1 \text{ ft})/(A)$, where:

V_d is the required dose volume, in gallons, determined as prescribed in N.J.A.C. 7:9A-9.2(a)2;

V_{cp} is the internal volume of all pipes which will drain back into the dosing tank at the end of a dosing cycle, in gallons;

V_{pd} is the volume displacement, in gallons, of the pump and controls; and

A is the internal horizontal area of the dosing tank, in square feet.

iii. A high-water alarm switch shall be set four inches above the pump-on switch and shall activate visible and audible alarms which can be readily seen and heard by occupants within the building served. The high-water alarm switch shall meet the same requirements prescribed for pump-control switches in (f)7i above. The alarm and its switch shall not be on the same electrical circuit as the pump and its switches.

iv. All electrical contacts and relays shall be located outside of the dosing tank and a gas-tight seal shall be provided where electrical conduits enter the tank.

v. All electrical service lines from the home or facility to the pump control panel shall be protected by electrical conduit.

Amended by R.1993 d.294, effective June 21, 1993.
See: 24 N.J.R. 1987(a), 25 N.J.R. 2704(b).

7:9A-9.3 Connecting and delivery pipes

(a) Connecting pipes between pretreatment units and dosing tanks, distribution boxes or distribution networks, and delivery pipes discharging effluent from dosing tanks shall be of such size as to serve the connected fixtures but in no case less than one and one half inches in diameter. Delivery pipes from dosing tanks using siphons shall be one nominal size larger than the siphon to facilitate venting.

(b) Delivery pipes for pressure dosing networks shall be constructed of Polyvinyl Chloride (PVC) plastic (ASTM D 2665), schedule 40, SDR-21 or SDR-26; or Acrylonitrile-Butadiene-Styrene (ABS) plastic (ASTM 2661). Connecting pipes may be constructed of any of the following materials:

1. Plastic meeting the following criteria:

i. PVC (ASTM D 2665)—schedule 40, SDR-21 or SDR-26; or

ii. ABS (ASTM 2661).

2. Cast-iron; or

3. Other material acceptable to the administrative authority.

(c) All pipe joints in connecting pipes and delivery pipes shall be made water-tight and protected against damage by roots.

(d) Connecting pipes and delivery pipes shall be laid on a firm foundation satisfactory to the administrative authority.

(e) The alignment and grade of connecting pipes shall meet the following requirements:

i. Connecting pipes shall have a minimum grade of one-quarter inch per foot unless otherwise authorized by the administrative authority.

ii. Connecting pipes shall be laid in a continuous grade and, as nearly as possible, in a straight line. Drop manholes may be installed if found necessary. Horizontal bends, where required, shall not be sharper than 45 degrees. The inside angle between adjacent sections of pipe shall be no less than 135 degrees.

(f) In cases where the delivery pipe from the dosing tank will be installed higher than the maximum expected depth of frost penetration, measures shall be taken, as outlined in this subsection, to insure that the delivery pipe will drain at the end of each dosing cycle.

1. In the case of dosing tanks using pumps, when the low-water level in the tank is lower than the invert of the distribution box or distribution network, the delivery pipe shall be sloped back towards the dosing tank and there shall be no check-valve at the pump so that the delivery pipe will drain back into the dosing tank at the end of each dosing cycle. Also, a one-eighth inch weep hole shall be provided, at the invert of the pump discharge pipe, at a point which is above the high water level in the dosing tank.

2. In the case of dosing tanks using siphons, or when a pump is used and the elevation of the low-water level in the dosing tank is higher than the invert of the distribution box or distribution network, the distribution network must be designed so that the delivery pipe (as well as the manifold pipe, in pressure distribution systems) will drain out through the distribution laterals at the end of each dosing cycle. In the latter case, where a pump is used, a one-eighth inch weep hole shall be drilled in the delivery pipe, at its highest point within the dosing tank, to prevent effluent from siphoning out of the tank between dosing cycles.

Amended by R.1993 d.294, effective June 21, 1993.
See: 24 N.J.R. 1987(a), 25 N.J.R. 2704(b).

7:9A-9.4 Distribution boxes

(a) A distribution box shall be required for all gravity flow systems and all gravity dosing systems where the effluent shall be distributed between two or more distribution laterals which are not inter-connected. The following requirements shall be met:

1. Distribution boxes shall be water-tight and constructed of sound and durable materials which will resist decay or corrosion by sulphuric acid, frost damage, cracking or buckling due to backfilling or other anticipated stresses.

2. The distribution box shall be set perfectly level and shall be installed as follows:

i. In the case of disposal beds, the distribution box shall be installed directly on the filter material within the disposal bed.

ii. In the case of disposal trenches, the distribution box shall be set on a layer of gravel or a concrete footing extending downward below the maximum expected depth of frost penetration. Where gravel is used, the gravel shall extend laterally a minimum of six inches beyond the sides of the distribution box.

3. A separate outlet shall be provided for each distribution lateral. The inverts of all outlets shall be rigidly

set at the same level which shall be a minimum of two inches above the bottom of the box. When installation is complete the distribution box shall be filled with water at which time the installation shall be checked to make sure that it is level. Adjustments shall be made as necessary so that all outlets are permanently and securely fixed at exactly the same elevation prior to backfilling.

4. The invert of the inlet shall be at least one inch above the invert of the outlets. Where dosing is employed, or where the connecting pipe from the pre-treatment unit has a steep slope, measures shall be taken to prevent direct flow of effluent across the distribution box resulting in unequal distribution of effluent among the distribution box outlets. This may be accomplished by installation of a baffle or elbow within the distribution box or by use of two distribution boxes connected in series. In the latter case, all outlets of the first distribution box shall be sealed off except for the outlet which discharges to the second distribution box.

5. Distribution boxes shall be provided with a means of access which may be a removable lid in the case of smaller boxes. Access to larger boxes may be provided by means of manholes and inspection ports with removable water-tight covers. In any case, the following requirements shall be met:

i. Access openings must be adequate in size and located to facilitate removal of accumulated solids and inspection of the inlet and all outlets.

ii. All access openings shall be extended to within 12 to 18 inches of the finished grade surface.

iii. Access openings shall be constructed in such a manner as to prevent the entrance of surface water.

7:9A-9.5 Laterals; gravity distribution

(a) Gravity flow networks and gravity dosing networks may consist of a single distribution lateral, two or more laterals connected by means of elbows or tees, or two or more separate distribution laterals connected independently to a distribution box. Distribution laterals shall meet all the following requirements:

1. Distribution laterals shall be a minimum of three inches in diameter.

2. Distribution laterals shall consist of lengths of rigid perforated pipe connected with tight joints.

3. Spacing and arrangement of distribution laterals shall conform with N.J.A.C. 7:9A-10.3(d).

4. Perforations shall be evenly spaced along two rows running the length of the pipe, on each side, midway between the invert and the center-line which separates the upper and lower halves of the pipe. Perforations shall be no smaller than three-eighth inch and no longer than three-quarter inch in diameter.

5. Each individual distribution line shall be approximately level and shall be capped at the end, except where the laterals are connected together by loops. In no case shall the slope of the distribution lines be greater than two inches per 100 feet.

6. An inspection port shall be provided in each corner of the disposal bed or at each end of a disposal trench. Inspection ports shall consist of a perforated pipe with a removable cap, extending from the level of infiltration to finished grade.

(b) The following materials are acceptable for distribution laterals:

1. Clay pipe, standard and extra strength perforated (ASTM C-211); or
2. Plastic:
 - i. Acrylonitrile-Butadiene-Styrene (ABS) (ASTM D-2751);
 - ii. Polyvinyl Chloride (PVC) (ASTM D-2729, D-3033, D-3034);
 - iii. Styrene-Rubber (ASTM D-2852, D-3298); or
 - iv. Polyethylene, straight wall (ASTM D-1248).

Amended by R.1993 d.294, effective June 21, 1993.
See: 24 N.J.R. 1987(a), 25 N.J.R. 2704(b).

7:9A-9.6 Pressure dosing networks

(a) Pipe networks for pressure dosing systems shall consist of two or more distribution laterals connected to a central or end manifold. The following requirements shall be met:

1. The size of laterals shall be no less than one but no greater than three inches in diameter and shall be chosen in conformance with N.J.A.C. 7:9A-9.7(a)3. The size of the manifold pipe shall be chosen in conformance with N.J.A.C. 7:9A-9.7(a)5.
2. Spacing and arrangement of laterals shall conform with the requirements of N.J.A.C. 7:9A-10.3(d).
3. All joints and connections shall be water-tight. Solvent-weld joints shall be used.
4. Holes shall be spaced evenly, in a straight line along the invert of each lateral. Hole diameter and spacing may vary from one-quarter to one-half inch and from 30 to 60 inches, respectively, and shall be chosen in conformance with N.J.A.C. 7:9A-9.7(a)2. In bed systems, holes in adjacent laterals shall be off-set by one-half the hole spacing so that the distance between holes in adjacent laterals is maximized. All holes shall be deburred.
5. The ends of the laterals shall be capped. A small hole shall be drilled horizontally in the end-cap of each lateral, near the crown, to facilitate venting at the beginning of each dosing cycle.

6. Each individual distribution line shall be approximately level. In no case shall the slope of the distribution lines be greater than two inches per 100 feet.

7. An inspection port shall be provided in each corner of a disposal bed or at each end of a disposal trench. Inspection ports shall consist of a perforated pipe with a removable cap, extending from the level of infiltration to finished grade.

8. Pressure dosing networks shall be constructed of PVC plastic (ASTM D-2662), schedule 40, SDR-21 or SDR-26, or ABS plastic (ASTM 2661) pipe.

Amended by R.1993 d.294, effective June 21, 1993.
See: 24 N.J.R. 1987(a), 25 N.J.R. 2704(b).

7:9A-9.7 Design procedure for pressure dosing systems

(a) The following procedure shall be used for disposal fields consisting of a disposal bed or disposal trenches which are at equal elevations.

1. Step One: Determine the length, number and spacing of distribution laterals based upon the required size of the disposal field, determined as prescribed in N.J.A.C. 7:9A-10.2, and the requirements for spacing of disposal trenches or the requirements for spacing of distribution laterals within disposal beds as prescribed in N.J.A.C. 7:9A-10.3(d). The number of distribution laterals will also depend upon whether a central or end manifold arrangement is used.
2. Step Two: Select the hole diameter and spacing. The hole diameter shall be a minimum of one-quarter inch but no larger than one-half inch. The minimum allowed hole spacing shall be 30 inches. The maximum allowed hole spacing shall be 60 inches, except in the case of systems installed in soils or fill material with a permeability faster than six inches per hour or a percolation rate faster than 15 minutes per inch, in which case the maximum allowed hole spacing shall be 36 inches.
3. Step Three: Based upon the hole diameter and the hole spacing selected and the length of the laterals, determine the required diameter of laterals using Figure 14 of Appendix A. If the disposal field configuration is such that it is beyond the applicable limits of Figure 14, other methods of hydraulically evaluating adequate lateral diameter may be used subject to prior approval by the administrative authority.
4. Step Four: Pressure distribution systems shall be designed so that a minimum pressure head of 2.5 feet shall be maintained at the supply end of the laterals. Based upon the hole diameter and the design pressure head at the supply end of the laterals, determine the hole discharge rate from the table below. Determine the lateral discharge rate by multiplying the hole discharge rate by the number of holes per lateral.

Pressure Head (ft.)	Discharge Rate (gallons per minute) based on Hole Diameter (inches)				
	$\frac{1}{4}$	$\frac{3}{8}$	$\frac{1}{2}$	$\frac{5}{8}$	$\frac{3}{4}$
2.5	1.18	1.85	2.66	3.63	4.73
3.0	1.28	1.99	2.87	3.91	5.10
3.5	1.40	2.19	3.15	4.29	5.60
4.0	1.47	2.30	3.31	4.51	5.89
4.5	1.59	2.48	3.57	4.86	6.35
5.0	1.65	2.57	3.71	5.04	6.59

5. Step Five: Based upon the number of laterals and the lateral spacing, determine the manifold length. Based upon the manifold length, the lateral discharge rate and the number of laterals, using Figure 15 of Appendix A, determine the required manifold diameter. If the disposal field configuration is such that it is beyond the applicable limits of Figure 15, other methods of hydraulically evaluating proper manifold diameter may be used subject to approval by the administrative authority.

6. Step Six: Determine the necessary system discharge rate by multiplying the lateral discharge rate by the number of laterals; and

7. Step Seven: For pump systems, select the proper pump as follows:

i. Using Figure 16 of Appendix A, determine the friction head based upon the system discharge rate and the diameter and length of the delivery pipe. If the system discharge rate is such that it is beyond the applicable limits of Figure 16, then other methods of determining friction head in the delivery pipe may be used subject to approval by the administrative authority.

ii. Calculate the total operating head, H_t , using the following formula:

$$H_t, \text{ ft} = H_f + H_e + H_p$$

where:

H_f is the friction head, in feet, determined in (a)7i above;

H_e is the elevation head, in feet, calculated by subtracting the dosing tank low water elevation from the elevation of the invert of the distribution laterals; and

H_p is the design pressure head to be maintained at the supply end of the laterals, in feet.

iii. Choose a pump which is rated by the manufacturer to deliver a flow rate equal to or greater than the system discharge rate calculated in Step Six when working against a total dynamic head equal to the total operating head calculated in (a)7ii above.

8. Alternate Step Seven: For systems using syphons, determine the syphon elevation as follows:

i. Determine the friction head in the delivery pipe as in (a)7i above.

ii. Calculate the velocity head using the following formula:

$$H_v, \text{ ft} = (D/A)^2/2g$$

where:

D = System Discharge Rate, ft^3/sec .

= (System Discharge Rate, gpm) (1 $\text{ft}^3/7.48$ gal) (1 min/60 sec)

A = pipe area, ft^2

= [(internal pipe diameter, in/2) (1 ft/12 in)]² (3.14)

g = 32.2 ft/sec^2

iii. Calculate the total operating head, H_t , by the following equation:

$$H_t, \text{ ft} = H_f + H_v + H_p$$

where:

H_f is the friction head, in feet, determined from Figure 16 of Appendix A.

H_v is the velocity head, in feet, determined in (a)8ii above.

H_p is the design pressure head to be maintained at the supply end of the laterals, in feet.

iv. Choose a syphon rated to discharge at a flow rate equal to or greater than the system discharge rate. Install the syphon at an elevation such that the syphon invert is higher than the invert of the distribution laterals by a distance equal to the total operating head calculated in (a)7iii above.

(b) If a trench system is proposed where the elevation of the infiltrative surface will not be the same in all trenches, the design engineer must demonstrate by means of appropriate calculations to the satisfaction of the administrative authority, that all portions of all trenches will receive equal hydraulic loading in conformance with the requirements of N.J.A.C. 7:9A-10.2. One way of accomplishing this would be to divide the disposal field into sections consisting of individual trenches or groups of trenches which are at the same elevation and which are dosed individually in conformance with the requirements of this section.

Amended by R.1993 d.294, effective June 21, 1993.
Sec: 24 N.J.R. 1987(a), 25 N.J.R. 2704(b).

SUBCHAPTER 10. DISPOSAL FIELDS

7:9A-10.1 General design requirements for disposal fields

(a) A disposal field shall be required for all new systems except as allowed in N.J.A.C. 7:9A-7.6, in which case a seepage pit may be approved in lieu of a disposal field. The disposal field shall consist of one or more disposal trenches

or a disposal bed designed, constructed and installed as hereafter prescribed.

(b) The disposal field installation shall be such that the disposal field is underlain by a suitable zone of treatment as prescribed in (d) below and a suitable zone of disposal as prescribed in (e) below. Acceptable options for disposal field installation are as follows:

1. Conventional installation: The disposal field shall be installed directly within the native soil and the level of infiltration shall be from one to three feet below the existing ground surface, as shown in Figure 17 of Appendix A.

2. Soil replacement, bottom-lined installation: The excavation for the disposal bed or each individual trench shall be extended below the level of infiltration and back-filled up to the level of infiltration with suitable fill. The disposal bed or trenches shall be installed on top of the fill with the level of infiltration one to three feet below the existing ground surface, as shown in Figure 18 of Appendix A.

3. Soil replacement, fill-enclosed installation: An excavation shall be made below the level of infiltration and extending laterally a minimum of two feet beyond the perimeter of the disposal field on all sides. This excavation shall be back-filled with suitable fill, the disposal bed or trenches installed within the fill, and the level of infiltration shall be one to three feet below the existing ground surface, as shown in Figure 19 of Appendix A.

4. Mounded installation: Fill material shall be placed above the ground surface; the disposal field shall be installed within the fill; and the level of infiltration shall be one to four feet above the existing ground surface (measured on the upslope side of the disposal bed or each individual disposal trench), as shown in Figure 20 of Appendix A.

5. Mounded soil replacement installation: An excavation shall be made below the ground surface; fill material shall be placed within this excavation and mounded up above the existing ground surface; the disposal field shall be installed within the fill; and the level of infiltration shall be between one foot and four feet above the ground surface (measured on the upslope side of the disposal bed or each individual disposal trench), as shown in Figure 21 of Appendix A.

(c) The type of disposal field installation permitted shall be determined based upon the soil suitability class as outlined in Table 10.1, below.

TABLE 10.1 TYPE OF DISPOSAL FIELD INSTALLATION

C = Conventional Installation
 SRB = Soil Replacement, Bottom-lined Installation
 SRE = Soil Replacement, Fill-enclosed Installation
 M = Mound Installation
 MSR = Mounded Soil Replacement Installation¹

Type of Limiting Zone	Depth ² , Ft.	Suitability Class	Type of Installation Permitted ³
Fractured Rock or Excessively Coarse Substratum	>5	I	C, (SRB,SRE,M,MSR)
Massive Rock	0-5	IISc	SRE, M, (MSR)
Hydraulically Restrictive Substratum	>9	I	C, (SRB,SRE,M,MSR)
Hydraulically Restrictive Substratum	4-9	IIISr	M, (MSR)
Hydraulically Restrictive Horizon,	<4	IIISr	UNSUITABLE
Permeable Substratum	>9	I	C, (SRB,SRE,M,MSR)
Excessively Coarse Horizon	4-9	IIHr	SRB, SRE, M, (MSR)
Zone of Saturation, Regional	<4	IIHr	SRB, SRE, (MSR)
Zone of Saturation, Perched	>5	I	C, (SRB,SRE,M,MSR)
	2-5	IIWr	M, (MSR)
	<2	IIWr	UNSUITABLE
	>5	I	C, (SRB, SRE,M,MSR)
	2-5	IIWp	C ⁴ , (SRB ⁴ , SRE,M,MSR)
	<2	IIWp	C ⁴ , (SRB ⁴ , SRE,M,MSR)

¹ Mounded soil replacement systems are generally required only in cases where several limiting zones are present as, for example, in compound soil suitability classes such as IIScWr, IIHr (IISr) or IIHr (IIWr).

² Depth is measured from the existing ground surface to the top of the limiting zone. In the case of disturbed ground, the depth to the limiting zone shall be measured from the preexisting natural ground surface, identified as prescribed in N.J.A.C. 7:9A-5.10(c), or the existing ground surface, whichever is lowest.

³ Installations shown in parentheses are allowed but are generally not the most cost-effective type of installation for the soil suitability class unless other soil limitations are present.

⁴ An interceptor drain or other means of removing the perched zone of saturation is required.

Note: In soils with a compound soil suitability class, where more than one limiting zone is present in the soil, a disposal field installation shall not be approved unless the type of installation proposed is listed in Table 10.1 as an acceptable option for each of the soil suitability classes which apply.

(d) A zone of treatment (see Figures 22, 23 and 24 in Appendix A), a minimum of four feet in thickness, shall be present below the disposal field and shall meet all of the following requirements:

1. The zone of treatment shall be composed of suitable soil which meets all of the criteria listed in (d)2 below, suitable fill material which satisfies the requirements of (f) below, or a combination of suitable soil and suitable fill.

2. Suitable soil within the zone of treatment shall meet the following criteria:

i. Coarse fragment content less than 50 percent by volume;

ii. Permeability less than 20 inches per hour and greater than 0.2 inches per hour, or a percolation rate slower than three minutes per inch and faster than 60 minutes per inch.

3. The zone of treatment shall not contain or be interrupted by fractured or massive rock substrata, hydraulically restrictive horizons or substrata, perched zones of saturation or regional zones of saturation. When excessively coarse horizons or substrata are present above, within or below the zone of treatment, these horizons shall not be considered part of the zone of treatment.

4. For design purposes, the top of the zone of treatment shall be considered to be the bottom of the disposal field or the bottom of an excessively coarse horizon when such a horizon is present immediately below the bottom of the disposal field. The bottom of the zone of treatment shall be considered to be whichever of the features listed below occurs at a shallower depth below the disposal field, except that in no case shall the bottom of the zone of treatment extend to a depth greater than eight feet below finished grade.

- i. An imaginary horizontal surface at a depth of four feet below the top of the zone of treatment, excluding the thickness of any intervening excessively coarse horizons;
- ii. The top of the shallowest limiting zone which is present in the soil below the disposal field; or
- iii. The bottom of the shallowest soil profile pit or boring made within the area of the disposal field.

(e) A zone of disposal (see Figures 22, 23 and 24 in Appendix A), a minimum of four feet in thickness, shall be present below the zone of treatment and shall meet all of the following requirements:

1. The zone of disposal shall be composed of native soil or rock material which has a permeability more rapid than 0.2 inch per hour or a percolation rate more rapid than 60 minutes per inch;
2. When the permeability in the zone of disposal has been determined, as prescribed in N.J.A.C. 7:9A-6, to be two inches per hour or faster, the minimum required thickness of the zone of disposal may be reduced to two feet. This determination shall not be made using the percolation test or basin flooding test;
3. The zone of disposal shall not contain or be interrupted by any hydraulically restrictive horizon unless the entire thickness of this horizon has been removed throughout the entire area of the disposal field and has been replaced with fill material meeting the requirements of (f)5 below. The thickness of any restrictive horizon which has been removed shall not be counted as part of the zone of disposal; and

4. For design purposes, the top of the zone of disposal shall be taken as the bottom of the zone of treatment. The bottom of the zone of disposal shall be considered to be whichever of the following features is present at a shallower depth below the disposal field:

- i. The top of any massive rock or hydraulically restrictive substratum;
- ii. The top of the shallowest hydraulically restrictive horizon which occurs below the bottom of the disposal field, except when the hydraulically restrictive horizon is to be removed and replaced with suitable fill materials; or

iii. The bottom of the shallowest soil profile pit or boring made below the disposal field.

(f) When fill material is used in disposal field construction, the following requirements shall be met:

1. When a soil replacement installation is proposed, the zone of treatment may consist partly or entirely of fill material provided that the requirements of N.J.A.C. 7:9A-10.4 are satisfied and the fill material used meets the requirements of (f)4 below. The zone of disposal may contain a layer of fill provided that the fill material used within the zone of disposal meets the requirements of (f)5 below.

2. When a mound installation is proposed, the zone of treatment may consist partly or entirely of fill material provided that the requirements of N.J.A.C. 7:9A-10.5 are satisfied and the fill material used meets the requirements of (f)4 below.

3. When a mounded soil replacement installation is proposed, the zone of treatment may consist partly or entirely of fill material provided that the requirements of N.J.A.C. 7:9A-10.6 are satisfied and the fill material used meets the requirements of (f)4 below. The zone of disposal may contain a layer of fill provided that the fill material used within the zone of disposal meets the requirements of (f)5 below.

4. When fill material is utilized within the zone of treatment, the fill shall meet the following requirements:

- i. Coarse fragment content less than 15 percent by volume or less than 25 percent by weight;
- ii. Textural analysis (composition, by weight, of size fraction passing the two millimeter sieve): from 85 to 95 percent sand, from five to 15 percent silt plus clay, minimum two percent clay; and
- iii. Permeability from two to 20 inches per hour; or percolation rate from three to 30 minutes per inch.

5. When fill material is placed within the zone of disposal, the fill material shall meet the following requirements:

- i. Textural analysis (composition, by weight, of size fraction passing the two millimeter sieve): 85 percent or more sand; and
- ii. Permeability greater than two inches per hour; or percolation rate faster than 30 minutes per inch.

(g) The following requirements shall be met when installing a disposal field in sloping ground:

1. The interface between filter material and the underlying soil or fill material at the bottom of each individual trench or bed shall be level;

2. On strongly sloping sites the shape of the disposal field shall be elongated with the long axis parallel to the topographic contour;

3. When the slope is greater than 10 percent, trenches shall be used rather than beds;

4. Mound or mounded soil replacement installations shall be restricted to slopes less than 10 percent; and

5. When disposal trenches are installed at different elevations and gravity flow or gravity dosing are used, the distribution of effluent between trenches shall be accomplished by means of a distribution box.

(h) When a conventional or soil replacement installation is proposed, the bottom of the disposal field shall be at a depth of from one to three feet below the existing ground surface. When a mound or mounded soil replacement installation is proposed, the level of infiltration shall be at an elevation no higher than four feet above the existing ground surface, measured on the upslope side of the disposal bed or each individual disposal trench. In no case shall the level of infiltration be greater than three feet below the finished grade.

7:9A-10.2 Disposal field sizing requirements

(a) The minimum required disposal field size or the maximum allowable hydraulic loading rate shall be determined, using sizing criteria as prescribed below, based upon the volume of sanitary sewage, determined as prescribed in N.J.A.C. 7:9A-7.4, and the results of permeability tests or percolation tests performed as prescribed in N.J.A.C. 7:9A-6.

1. The disposal field sizing criteria to be used shall be determined based upon the type of disposal field, disposal field installation and the method of effluent distribution used, as follows:

TABLE 10.2(a) APPLICABLE DISPOSAL FIELD SIZING CRITERIA

Type of Disposal Field Installation	Type of Disposal Field	Method of Distribution	Applicable Sizing Criteria
Conventional	Trench	Gravity	N.J.A.C. 7:9A-10.2(b)
		Pressure	N.J.A.C. 7:9A-10.2(b)
	Bed	Gravity	N.J.A.C. 7:9A-10.2(c)
		Pressure	N.J.A.C. 7:9A-10.2(c)
Soil Replacement, Bottom-lined	Trench	Gravity	N.J.A.C. 7:9A-10.2(c)
		Pressure	N.J.A.C. 7:9A-10.2(d)
	Bed	Gravity	N.J.A.C. 7:9A-10.2(c)
		Pressure	N.J.A.C. 7:9A-10.2(d)
Soil Replacement, Fill-enclosed	Trench	Gravity	N.J.A.C. 7:9A-10.2(b)
		Pressure	N.J.A.C. 7:9A-10.2(b)
	Bed	Gravity	N.J.A.C. 7:9A-10.2(c)
		Pressure	N.J.A.C. 7:9A-10.2(d)
Mound, Mounded Soil Replacement	Trench	Gravity	N.J.A.C. 7:9A-10.2(b)
		Pressure	N.J.A.C. 7:9A-10.2(b)
	Bed	Gravity	N.J.A.C. 7:9A-10.2(c)
		Pressure	N.J.A.C. 7:9A-10.2(d)

(b) All disposal fields using trenches, except for bottom-lined soil replacement installations, shall meet the following size requirements:

1. The minimum required length of trenches per gallon of daily sewage volume, L/Q, shall be determined from Table 10.2(b) below, based upon the trench width selected and the results of permeability tests or percolation tests, performed as prescribed in N.J.A.C. 7:9A-6.

2. The minimum required length of trenches, L, shall then be determined by multiplying the value of L/Q obtained from the table by the daily volume of sewage, Q, determined as prescribed in N.J.A.C. 7:9A-7.4.

(c) All disposal beds using gravity flow or gravity dosing, all conventionally installed disposal beds using pressure dosing and all bottom-lined soil replacement trench installations using gravity flow or gravity dosing shall meet the following size requirements.

1. The minimum required bottom area of disposal field per gallon of daily sewage volume, A/Q, shall be determined from Table 10.2(c) below, based upon the results of permeability tests or percolation tests performed as prescribed in N.J.A.C. 7:9A-6.

2. The minimum required bottom area shall then be determined by multiplying the value of A/Q obtained from the table by the daily volume of sewage, Q, in gallons, determined as prescribed in N.J.A.C. 7:9A-7.4.

(d) All disposal beds using pressure dosing except for conventional installations and all bottom-lined soil replacement trench installations using pressure dosing shall have a minimum size of 1.33 square feet of bottom area per gallon of daily sewage volume.

TABLE 10.2(b) MINIMUM REQUIRED DISPOSAL TRENCH LENGTH PER GALLON OF DAILY SEWAGE VOLUME, L/Q (ft/gal per day)

Permeability (in/hr)	Percolation Rate (min/in)	Trench Width (ft):	L/Q (ft/gal per day) ⁽¹⁾			
			1.5	2.0	2.5	3.0
6-20	3-15		0.65	0.54	0.46	0.40
2-6	16-30		0.83	0.69	0.59	0.52
0.6-2	31-45		1.03	0.85	0.73	0.64
0.2-0.6	46-60		1.18	0.98	0.84	0.74

TABLE 10.2(c) MINIMUM REQUIRED DISPOSAL FIELD BOTTOM AREA PER GALLON OF DAILY SEWAGE VOLUME, A/Q¹ (ft²/gal per day)

Permeability (in/hr)	Percolation Rate (min/in)	A/Q ⁽¹⁾ (ft ² /gal per day)	
		1.5	2.0
6-20	3-15	1.61	2.08
2-6	16-30	2.56	2.94
0.6-2	31-45		
0.2-0.6	46-60		

¹ Additional Requirements:

a. Where garbage disposal units are installed or proposed, the value obtained from this table shall be increased by a factor of 25 percent for use in disposal field sizing.

Amended by R.1993 d.294, effective June 21, 1993.

See: 24 N.J.R. 1987(a), 25 N.J.R. 2704(b).

7:9A-10.3 Specific requirements for conventional disposal field installations

(a) A conventional installation shall be made by placing the disposal bed or each individual disposal trench in an excavation made directly within the natural soil or, in the case of disturbed ground, within pre-existing fill material.

(b) All rough-grading shall be in accordance with the following requirements:

1. Sites which have been re-graded prior to site evaluation, soil evaluation or permeability testing shall be considered to be disturbed ground and all requirements relating to disturbed ground shall be met.

2. When a site is re-graded after site evaluation, soil evaluation or permeability testing, this re-grading shall be carried out in conformance with an engineering design which has been approved by the administrative authority.

3. On a re-graded site, the disposal field shall be placed only in those areas which have been lowered by cutting and no portion of the disposal field shall be placed within those areas which have been raised by filling.

(c) Excavation for the disposal field shall be in accordance with the following procedures:

1. Adequate measures shall be used to insure that the bottom of the disposal bed or each individual disposal trench is level.

2. In soil textures other than sands or loamy sands, excavation which exposes the infiltrative surface of the disposal field shall not be carried out when the soil moisture content is above the lower plastic limit. This means that when a small lump of soil, taken from the depth of the proposed excavation, can be rolled out with the fingers to form a wire or rod, one-eighth of an inch in thickness, and does not crumble when handled, the soil is too wet to proceed with the excavation.

3. Excavation shall be carried out in a manner that will avoid unnecessary compaction of the disposal field bottom and sidewalls. Heavy equipment such as bulldozers or front-end loaders shall not be driven over the exposed infiltrative surface of the disposal field. Excavation should be carried out with a backhoe operating from between disposal trenches or from outside the perimeter of previously excavated portions of the disposal bed. If it becomes necessary to walk on the disposal field bottom, a suitable board shall be laid over the soil to avoid trampling.

4. Any smeared or compacted soil surfaces which have been produced on the bottom or sidewalls of the excavation shall be removed to expose a fresh soil surface which is rough and uneven.

5. Work should be scheduled so that the bottom and sidewalls of the excavation will not be exposed to rainfall or wind-blown silt between the time of excavation and the time of final inspection and backfilling. Any loose soil or debris which is washed into or otherwise deposited within the excavation as a result of the excavation remaining open to the elements shall be carefully removed prior to backfilling.

(d) The construction of the distribution network shall be in accordance with N.J.A.C. 7:9A-9.5, when gravity flow or gravity dosing is used, or N.J.A.C. 7:9A-9.6, when pressure dosing is used. Additional requirements for disposal trenches or beds are given in (d)1, and 2 below, respectively.

1. Disposal trenches shall be constructed in accordance with the following requirements:

i. The minimum spacing between trenches (sidewall to sidewall) shall be six feet.

ii. The minimum width of trenches shall be 1.5 feet.

iii. The maximum width of trenches shall be three feet.

iv. There shall be one distribution line per trench.

2. Disposal beds shall be constructed in conformance with the following requirements:

i. There shall be a minimum of two distribution lines per bed.

ii. The maximum distance from edge of bed to nearest distribution line shall be three feet.

iii. The minimum distance from edge of bed to nearest distribution line shall be one foot.

iv. The maximum spacing between distribution lines for gravity distribution shall be three feet.

v. The required spacing between distribution lines for pressure distribution shall be from $3/4$ to $5/4$ of the hole spacing;

vi. The spacing between all distribution lines shall be equal and uniform; and

vii. Holes in pressure distribution lines shall be aligned so that holes in adjacent laterals shall be off-set by one-half the hole spacing.

(e) Filter material shall meet the following requirements:

1. Filter material shall cover the distribution lines and extend the full width of the trench or bed, shall extend between 12 and 18 inches deep beneath the bottom of the distribution lines and shall extend at least two inches above the top of the lines.

2. The filter material shall be washed gravel or crushed stone, free of fines, dust, ashes or clay. Refer to the New Jersey Department of Transportation standard sizes for coarse aggregates as shown in Figure 26 of Appendix A. The filter material shall conform in size and gradation to size number 24, size number three or size number four.

3. The filter material shall be covered with drainage fabric, untreated building paper or a four to eight inch thickness of salt-hay or straw, as the laying of the distribution lines progresses. When drainage fabric or untreated

building paper is used, the following requirements shall be met:

i. Edges of adjacent sheets shall be overlapped by a minimum of six inches.

ii. Drainage fabric shall be specified in the engineering design and shall have adequate tensile strength to prevent ripping during installation and backfilling, adequate air permeability to allow free passage of gases, and adequate particle retention to prevent downward migration of soil particles into the filter material.

iii. Use of water-proof paper is prohibited.

4. The filter material may be laid into the excavation using a backhoe, front-end loader or dump truck provided that this operation is carried out from sides of the system rather than by driving out onto the exposed disposal field infiltrative surface. In the case of large beds, tracked equipment may be operated within the disposal bed provided that the equipment does not exert a ground pressure in excess of eight pounds per square inch and provided that the filter material is pushed out in front of the vehicle while maintaining a minimum thickness of one foot of filter material below the vehicle tracks at all times.

(f) Backfill and final grading shall be carried out in accordance with the following requirements:

1. A minimum of nine inches and no more than 18 inches of backfill shall be placed over the top of the disposal field filter material.

2. Backfill material shall be of earth similar to that found at the site and free of large stones, tree stumps, broken masonry or other waste construction material.

3. In no case shall the backfill material be more permeable than the surrounding soil.

4. Backfill shall completely cover the entire disposal bed or each of the disposal trenches and shall be graded smoothly into the surrounding topography on all sides.

5. The following practices shall be followed:

i. Heavy machinery, rubber-tired vehicles or other vehicles exerting a ground pressure in excess of eight pounds per square inch shall not be permitted to pass over the disposal field after the filter material and distribution network have been installed.

ii. Tracked equipment may be used for the purpose of backfilling and final grading provided that this equipment does not exert a pressure on the underlying soil in excess of eight pounds per square inch.

iii. Final grading shall be completed in accordance with the approved engineering design and in such a manner that surface water will not collect over the disposal field.

iv. After completion of backfilling and final grading, the backfilled area over the disposal field shall be seeded or sodded to establish a vegetative cover or otherwise stabilized against erosion in a manner acceptable to the administrative authority.

7:9A-10.4 Specific requirements for soil replacement disposal field installations

(a) A soil replacement disposal field installation shall be made by installing the disposal bed or each individual disposal trench on top of or within suitable fill material which has been placed in an excavation made below the existing ground surface. In a bottom-lined installation, the fill material shall be placed below the disposal field only, as prescribed in (b) below. In a fill-enclosed installation, the fill shall be placed around the sides as well as below the disposal field, as prescribed in (c) below. The type of soil replacement disposal field installation required depends upon the soil limitations present and the slope across the disposal area as follows:

1. A fill-enclosed installation shall be required when:

i. The limiting zone is a perched zone of saturation underlain by a hydraulically restrictive horizon and the slope across the disposal field is less than five percent;

ii. The limiting zone is an excessively coarse horizon or substratum; or

iii. The limiting zone is a fractured rock substratum.

2. A bottom-lined installation may be permitted where:

i. The limiting zone is a hydraulically restrictive horizon and no perched zone of saturation is present; or

ii. The limiting zone is a perched zone of saturation underlain by a hydraulically restrictive horizon and the slope across the disposal field is five percent or greater.

(b) Bottom-lined soil replacement disposal field installations shall be constructed as follows:

1. An excavation shall be made within the area occupied by the disposal bed or by each individual disposal trench and, where the limiting zone is a hydraulically restrictive horizon, the excavation(s) shall extend a minimum of two feet below the bottom of the hydraulically restrictive horizon.

2. The excavation shall be backfilled to the level of infiltration with suitable fill material.

3. The disposal field shall be constructed on top of the fill material within the excavation(s).

4. An interceptor drain designed and constructed as prescribed in N.J.A.C. 7:9A-10.7 shall be provided to divert away from the disposal field laterally moving ground water which may be perched above any hydraulically restrictive horizon penetrated by the excavation.

(c) Fill-enclosed soil replacement disposal field installations shall be constructed as follows:

1. An excavation shall be made to the required depth extending throughout the entire area to be occupied by the disposal field and beyond the perimeter of the disposal field a minimum of two feet in all directions. In cases where the limiting zone is a fractured rock substratum and a pit-bailing or basin flooding test has been used to establish adequate permeability, the depth of the disposal field excavation shall be no less than the depth of the test pit.

2. The excavation shall be backfilled with suitable fill material.

3. The disposal field shall be constructed within the fill material so that the entire disposal bed or each individual trench is surrounded by a minimum of two feet of fill material on all sides.

(d) Requirements and restrictions relating to site regrading shall be the same as those prescribed for conventional installations in N.J.A.C. 7:9A-10.3(b).

(e) Excavation prior to the placement of fill material shall be carried out in accordance with the requirements of N.J.A.C. 7:9A-10.3(c)2 through 5.

(f) Fill material used in soil replacement disposal field installations shall meet the following requirements:

1. The fill material used below the disposal field shall meet the requirements for texture and permeability which are prescribed in N.J.A.C. 7:9A-10.1(f).

2. The minimum depth of fill below the disposal field shall be one foot.

3. Compaction of fill material shall be required whenever fill material is used below the disposal field and shall be carried out in accordance with the following requirements:

i. Compaction of fill shall be carried out as directed by a professional engineer and as indicated on the approved engineering design.

ii. Based upon a final inspection, a professional engineer shall certify by signature and seal that compaction of the fill has been performed adequately to prevent failure of any component of the system due to excessive settlement or differential settlement.

iii. Fill material shall be spread and compacted in layers one foot or less in thickness.

iv. Compaction may be accomplished manually or mechanically, by tamping or rolling, or by driving over the filled area in a controlled pattern using tracked or rubber-tired vehicles. Compaction may also be accomplished by puddling.

v. When heavy excavating equipment is operated within the excavation for the purpose of placement of compaction of the fill material, this equipment shall not be driven directly on the exposed bottom of the excavation. A minimum of one foot of fill material shall be maintained below the vehicle tracks or wheels at all times.

(g) Construction of the disposal field and distribution network shall be as prescribed for conventional installations in N.J.A.C. 7:9A-10.3(d).

(h) Filter material shall be as prescribed for conventional installations, in N.J.A.C. 7:9A-10.3(e).

(i) Backfill and final grading shall be as required in N.J.A.C. 7:9A-10.3(f) and shall extend a minimum of five feet, in all directions, beyond the perimeter of the filled area.

7:9A-10.5 Specific requirements for mounded disposal field installations

(a) A mounded disposal field installation shall be made by installing the disposal field as prescribed below, within suitable fill which has been placed above the existing ground surface.

(b) Requirements and restrictions relating to site regrading shall be the same as those prescribed for conventional installations in N.J.A.C. 7:9A-10.3(b).

(c) On sloping sites, the disposal field shall be elongated in shape with the long axis parallel to the topographic contour.

(d) Prior to placement of fill material, the ground surface shall be prepared as follows:

1. Excessive vegetation shall be cut and removed. Large trees including the stumps shall be removed. If large holes are left as a result of stump removal these shall be filled with fill material meeting the requirements of N.J.A.C. 7:9A-10.1(f)4.

2. The delivery pipe from the dosing tank shall be installed and the excavation backfilled and compacted prior to preparation of the ground surface for fill placement.

3. The area within the perimeter of the mound shall be plowed or disked to produce a thoroughly roughened surface. Plowing shall be done using a two bottom or larger moldboard plow or chisel plow and shall be parallel to the topographic contour in such a direction that each plow furrow will be thrown upslope. The soil should be

broken-up to a depth of six to eight inches. Alternatively, a roto-tiller may be used provided that the surface soil is of sand or loamy sand texture.

(e) A mound shall be constructed by placing a layer of fill material over the ground within and adjacent to the area of the disposal field. The method of emplacement and lateral extent of the fill material shall be as follows:

1. The area of the fill layer shall include the area of the disposal field plus a lateral extension of fill material surrounding the disposal field on all sides.

2. The minimum required width of the lateral fill extension shall be 20 feet where gravity distribution is to be used and five feet where pressure distribution is to be used.

3. Within the area of the lateral fill extension, the top surface of the fill material shall be kept level with or higher than the invert of the distribution laterals.

4. On sloping sites, the width of the lateral fill extension may be reduced on the upslope side of the disposal field provided that the top surface of the fill material is kept level with or higher than the invert of the distribution laterals up until the point where the top surface of the fill material intersects with the existing slope.

5. At the outside edge of the lateral fill extension, the mound shall be terminated by sloping the top surface of the fill layer downward at a slope of three to one or less. Alternatively, lateral support for the fill layer may be provided by a retaining wall or a berm of soil material meeting the requirements of N.J.A.C. 7:9A-10.3(f)2 and sloped at a grade of three to one or less.

6. Fill material below the disposal field and within the area of the lateral fill extensions shall be suitable fill material meeting the requirements of N.J.A.C. 7:9A-10.1(f)4.

7. Compaction of fill shall be carried out as prescribed in N.J.A.C. 7:9A-10.4(f).

(f) Construction and installation of the disposal field and distribution network shall be as prescribed for conventional installations in N.J.A.C. 7:9A-10.3(d).

(g) Filter material shall be as prescribed for conventional installations in N.J.A.C. 7:9A-10.3(e).

(h) Backfill and final grading over the mound shall be completed as follows:

1. Immediately above the disposal field filter material which has been covered with a suitable barrier material, as prescribed in N.J.A.C. 7:9A-10.3(e)3, a layer of topsoil, suitable for establishment of a good vegetative cover, 12 to 18 inches in thickness at the center of the mound and six to 12 inches in thickness at the edges, shall be placed over the entire mound, covering the top and side slopes. The topsoil shall be build up thicker along the long axis of the mound so that a convex profile is produced parallel to the direction of the slope. The topsoil shall be lightly compacted by tamping or rolling to prevent settlement.

2. Immediately after completion of final grading, the mound surface shall be mulched and seeded, or sodded, to establish a good vegetative cover and to prevent erosion.

7:9A-10.6 Specific requirements for mounded soil replacement disposal field installations

(a) Mounded soil replacement disposal fields shall be constructed as follows:

1. An excavation shall be made to the required depth throughout the entire area of the disposal field and extended laterally in all directions a minimum of two feet beyond the perimeter of the disposal field.

2. This excavation shall be backfilled with suitable fill material and the fill material mounded up over the excavation to produce a mound of the desired height in which to install the disposal field.

3. The sides of the mound shall be constructed with slopes of three to one or less.

(b) Requirements and restrictions relating to site regrading shall be the same as those prescribed for conventional installations in N.J.A.C. 7:9A-10.3(b).

(c) Excavation prior to placement of fill material shall be carried out as specified in N.J.A.C. 7:9A-10.3(c)2 through 5.

(d) Fill material shall meet the requirements of N.J.A.C. 7:9A-10.4(d).

(e) Construction of the disposal field and distribution network shall be as prescribed for conventional installations in N.J.A.C. 7:9A-10.3(d).

(f) Filter material shall be as prescribed for conventional installations, in N.J.A.C. 7:9A-10.3(e).

(g) Backfill and final grading shall be as prescribed for mounded installations, in N.J.A.C. 7:9A-10.5(h).

7:9A-10.7 Interceptor drains

(a) Interceptor drains may be used on sloping sites to improve site suitability by intercepting laterally moving ground water which is perched above a hydraulically restrictive horizon provided that the requirements of (b) through (k) below are met.

(b) Interceptor drains shall be oriented parallel to the length and width of the disposal field and shall be installed on all sides except for the downslope side, as shown in Figure 25 of Appendix A.

(c) Interceptor drains designed to intercept ground water which is perched above a hydraulically restrictive horizon shall extend to the top but not through the entire thickness of the hydraulically restrictive horizon.

(d) The minimum distance between the disposal field and an interceptor drain shall be as prescribed in (d)1 and 2 below. The only exceptions to these requirements shall be where the bottom of the drain is at an elevation which is higher than the bottom of the disposal field or where the drain is set at the top of a restrictive horizon which is penetrated by the excavation for a soil replacement or mounded soil replacement installation, in which cases the minimum setback distance between the disposal field and the drain shall be 20 feet.

1. The minimum distance between a disposal field and any portion of an interceptor drain which is downslope of the disposal field shall be 50 feet.

2. The minimum distance between a disposal field and those portions of the interceptor drain which are upslope of the disposal field's downslope side shall be 50 feet unless a shorter distance is calculated using the formula given in (d)3 below. In no case shall this distance be less than 10 feet.

3. Calculate the minimum required horizontal separation distance, D , using the equation, $D = Q/(LKI^2)$, where:

Q is the volume of sanitary sewage, determined as prescribed in N.J.A.C. 7:9A-7.4, in gallons per day, multiplied by a unit conversion factor of $1 \text{ ft}^3/7.48$ gallons.

L is the total length of the disposal field, in feet, measured parallel to the topographic contour.

K is the horizontal saturated permeability above the restrictive horizon, in inches per hour, determined as prescribed in N.J.A.C. 7:9A-6.5 or 6.6, multiplied by unit conversion factors of (1 foot/12 inches) and (24 hours/1 day).

I is the slope, in feet/foot, measured perpendicular to the topographic contour and described based on appropriately located subsurface explorations.

(e) Excavation shall be carried out as follows:

1. The excavation for the interceptor drain shall be made to the exact depth required in (c) above, a minimum two feet wide, and shall extend for the entire length of the drain, around the upslope side of the disposal field and down both ends of the field to the downslope side, as shown in Figure 25 of Appendix A.

2. To accommodate the drain discharge pipes, the excavation shall extend, on each end of the disposal field, beyond the extent of the drain, from the downslope side of the disposal field to free-flowing outlet meeting the requirements of (f) below.

3. The part of the excavation in which the drain discharge pipe will be laid shall have a slope which is steep enough to carry away the intercepted ground water.

(f) That portion of the excavation which will accommodate the drain shall be filled with filter material to a depth which is a minimum of one foot higher than the top of the perched zone of saturation which is to be drained. Filter material used for this purpose shall be washed gravel or crushed stone, free of fines, dust, ashes or clay, and shall conform in size and gradation with one of the following New Jersey Department of Transportation standard sizes for coarse aggregate as shown in Figure 26 of Appendix A: size number four, size number five, size number 56 or size number six.

(g) Barrier material shall consist of continuous layers of drainage fabric and shall be placed throughout the entire length of the drain, above, below and along the sides of the filter material. The following requirements shall be met:

1. The edges of adjacent sheets shall be overlapped by a minimum of six inches.

2. The type of drainage fabric used shall be specified in the engineering design and shall have adequate tensile strength to prevent ripping during installation and back-filling, adequate permeability to allow unimpeded passage of water, and adequate particle retention to prevent migration of soil particles into the filter material.

(h) Drainage pipe shall be laid throughout the entire length of the excavation and shall be placed immediately above the barrier material at the bottom of the excavation and midway between the sides. The type of drainage pipe used shall be as follows:

1. Upslope of the downslope side of the disposal field, where the excavation is filled with filter material, the pipe shall be perforated or laid with open joints.

2. Downslope of the downslope edge of the disposal field, and beyond the extent of the filter material, the pipe shall be non-perforated and laid with tight joints.

3. The size of the pipe shall be large enough to handle the expected amount of flow and in no case shall the pipe diameter be less than four inches.

4. Materials used for drainage pipe shall be as allowed in N.J.A.C. 7:9A-9.5(b).

(i) Free-flowing outlets shall be provided downslope of the drain, on each end of the disposal field. Outlets shall meet the following requirements:

1. Outlets may empty into a surface water body, a drainage swale discharging to a surface water body, a storm sewer, a groundwater recharge basin or a gravel bed.

2. Outlets shall be designed, constructed, located and maintained in a manner which does not cause soil erosion, surface flooding or damage to adjacent properties, does not create a public nuisance, and does not violate any applicable Federal, State or local laws or regulations.

3. Adequate measures shall be taken to protect each outlet from entry of rodents or other small animals.

(j) Backfill over the drain and the drain discharge pipes shall be of earth similar to that found at the site and free of large stones, broken masonry, stumps or other waste construction material.

(k) Where an interceptor drain is proposed to divert laterally moving perched ground water away from the area of the disposal field, the drain shall be installed and its satisfactory performance confirmed prior to granting of final approval, as follows.

1. After installation of the drain has been completed, borings or pits shall be excavated to the top of (but not penetrating) the hydraulically restrictive horizon, hydraulically restrictive substratum or massive rock substratum above which the perched zone of saturation is located. This shall be done on the upslope and downslope sides of the drain and during a time of year when the presence of the perched zone of saturation is anticipated. Piezometers may also be used for this purpose provided that they do not penetrate through the hydraulically restrictive horizon and provided that the requirements of N.J.A.C. 7:9A-5.9(e) are met.

2. The drain shall be considered to be performing adequately if no perched zone of saturation is observed on the downslope side of the drain at the same time that a perched zone of saturation is observed on the upslope side of the drain. This test shall be witnessed by the administrative authority or its authorized agent.

SUBCHAPTER 11. SEEPAGE PITS

7:9A-11.1 Site/soil requirements

(a) Seepage pits shall not be approved except as specified in N.J.A.C. 7:9A-7.6. When a seepage pit is approved, the following site/soil requirements shall be met:

1. The bottom of any seepage pit shall be a minimum of eight feet above any hydraulically restrictive horizon or substratum not fully penetrated or any massive rock substratum.
2. The bottom of any seepage pit shall be a minimum of four feet above any fractured rock substratum.
3. The bottom of any seepage pit shall be a minimum of four feet above the level of the seasonally high water table.

7:9A-11.2 Design requirements

(a) The percolating area shall be considered to be the total outside surface of the seepage pit lining below the inlet and exclusive of any soil horizons with a percolation rate slower than 40 minutes per inch. The bottom of the seepage pit shall not be counted as part of the percolating area.

(b) The minimum required percolating area for dwelling units shall be determined from the following table, based upon a weighted average, of the percolation rates of all the soil layers exposed in the sidewalls, determined as prescribed in N.J.A.C. 7:9A-6.4(f)4. In no case, however, shall the percolating area be less than 110 square feet per dwelling unit.

Average Percolation Rate (Min/inch)	Minimum Area Per Bedroom Per Day (Square feet)
10 or less	72
11 to 20	108
21 to 30	144
31 to 40	180
over 40	not acceptable

(c) The minimum percolating area for facilities other than individual dwellings shall be determined from the following table based upon the volume of sanitary sewage, determined as prescribed in N.J.A.C. 7:9A-7.4, and a weighted average of the percolation rates of all soil layers exposed in the sidewalls, determined as prescribed in N.J.A.C. 7:9A-6.4(f)4. In no case, however, shall the percolating area be less than 110 square feet.

Average Percolation Rate (Min/inch)	Minimum Area Per Gallon Per Day (Square feet)
10 or less	0.48
11 to 20	0.72
21 to 30	0.96
31 to 40	1.20
over 40	not acceptable

7:9A-11.3 Construction requirements

(a) Seepage pits shall be constructed within an excavation affording adequate working space and shall be constructed of stone, brick, cinder, precast concrete or concrete block, or similar material laid dry with open joints where permeable strata has been penetrated, except that if the seepage pit is not of circular construction or if the surrounding ground is subject to cave-in, all horizontal joints shall be mortared in such a manner as to prevent structural failure. The following requirements shall be met:

1. All joints above the inlet, in all cases, shall be made water-tight.
2. Before placement of backfill, all sidewall areas shall be scarified.
3. The bottom of the seepage pit shall be filled with coarse gravel to a depth of one foot unless the bottom is in a sand or gravel formation.

(b) Seepage pits shall be backfilled according to the following procedure:

1. The space between the excavation and the seepage pit wall shall be backfilled with at least three inches of coarse gravel or filter material meeting the requirements of N.J.A.C. 7:9A-10.3(e)2.

2. Where cinder or concrete blocks are laid with core openings exposed, the space between the excavation and seepage pit wall shall be backfilled with at least six inches of two and one-half inch crushed stone or gravel.

3. Backfill above the inlet shall be as required for disposal fields in N.J.A.C. 7:9A-10.3(f)2 and shall be thoroughly compacted by hand or mechanical tamping methods. The use of heavy machinery for this purpose is prohibited.

(c) Covers shall be constructed of reinforced concrete, shall be a minimum of three inches in thickness, water-tight, and shall be designed and constructed so as not to be damaged by any load which is likely to be placed upon them.

(d) At least one access opening with a removable water-tight cover and a minimum dimension of 24 inches shall be provided. Access openings shall meet the following requirements:

1. Access shall be adequate to permit pumping out of the pit as well as inspection and maintenance of the inlet.

2. When the cover of the seepage pit is deeper than 12 inches below finished grade, the access opening shall be extended to within 12 inches of finished grade by means of a concrete riser with a cast-iron manhole cover.

3. When the access opening is below finished grade, a permanent marker at finished grade shall be provided to indicate its location.

4. When the access opening is at or above finished grade, the cover shall be bolted, locked or otherwise secured to prevent access by children.

(c) As set forth in N.J.S.A. 58:10A-17, no person shall use or introduce or cause any other person to use or introduce into any individual subsurface sewage disposal system any sewage system cleaner containing any restricted chemical material.

(d) Disposal of materials containing toxic substances into an individual subsurface sewage disposal system is prohibited. Material containing toxic substances include, but are not limited to, waste oil (other than cooking oil), oil-based or acrylic paints, varnishes, photographic solutions, pesticides, insecticides, paint thinners, organic solvents or degreasers and drain-openers.

(e) Inert or non-biodegradable substances shall not be disposed of in the individual subsurface sewage disposal system. Such substances include, but are not limited to, disposable diapers containing plastic, cat box litter, coffee grounds, cigarette filters, sanitary napkins, facial tissues and wet-strength paper towels.

(f) Large quantities of cooking greases or fats shall not be discharged into systems not equipped with a grease trap designed and constructed as prescribed in N.J.A.C. 7:9A-8.1.

(g) Major plumbing leaks shall be repaired promptly to prevent hydraulic overloading of the system.

7:9A-12.2 (Reserved)

Repealed by R.1993 d.294, effective June 21, 1993.
See: 24 N.J.R. 1987(a), 25 N.J.R. 2704(b).

7:9A-12.3 (Reserved)

Repealed by R.1993 d.294, effective June 21, 1993.
See: 24 N.J.R. 1987(a), 25 N.J.R. 2704(b).

7:9A-12.4 (Reserved)

Repealed by R.1993 d.294, effective June 21, 1993.
See: 24 N.J.R. 1987(a), 25 N.J.R. 2704(b).

7:9A-12.5 (Reserved)

Repealed by R.1993 d.294, effective June 21, 1993.
See: 24 N.J.R. 1987(a), 25 N.J.R. 2704(b).

7:9A-12.6 (Reserved)

Repealed by R.1993 d.294, effective June 21, 1993.
See: 24 N.J.R. 1987(a), 25 N.J.R. 2704(b).

7:9A-12.7 System testing

No person shall test an individual subsurface sewage disposal system in a manner that will adversely affect the functioning of the system. Hydraulic loading shall not be applied in excess of the design flow capacity of the septic tank and/or grease trap unless all solids have been removed from the septic tank and/or grease trap prior to testing or unless the hydraulic loading is applied at a point that will bypass the septic tank and/or grease trap. All testing of operating systems which requires a hydraulic loading which is in excess of the design flow shall be performed under the supervision of a licensed professional engineer.

SUBCHAPTER 12. OPERATION AND MAINTENANCE

7:9A-12.1 System use

(a) The individual subsurface sewage disposal system shall be used only for the disposal of wastes of the type and origin provided for in the approved engineering design. No permanent or temporary connection shall be made to any source of wastes, wastewater or clean water other than those plumbing fixtures which are normally present within the type of facility indicated in the approved engineering design.

(b) Drainage from basement floors, footings or roofs shall not enter the individual subsurface sewage disposal system and shall be diverted away from the area of the disposal field. Backwash from water softeners shall not be disposed of within the individual sewage disposal system but may be discharged into a drywell located away from the area of the disposal field.

7:9A-12.8 Abandoned systems

(a) When it is necessary to abandon a system or components of a system in place for any reason other than connection to a sanitary sewer line, all septic tanks, dosing tanks, seepage pits, dry wells and cesspools which are to be abandoned shall be emptied of wastes and removed or filled completely with gravel, stones or soil material in a manner which is acceptable to the administrative authority. In cases where the individual subsurface sewage disposal system, or components thereof, is being abandoned due to the connection of the facility to a sanitary sewer line, the local plumbing inspector shall ensure the system is abandoned in accordance with the requirements of this section.

(b) When components or residuals, such as gravel filter material, fill material or soil from an abandoned individual subsurface sewage disposal system are removed from the ground, such components or residuals shall be managed as follows:

1. Off-site disposal of components and residuals from an abandoned system shall be managed in accordance with the State Solid Waste Management Act, N.J.S.A. 13:1E-1 et seq., and the rules promulgated pursuant thereto; or

2. On-site management of excavated components and residuals from abandoned systems shall be in accordance with the State Solid Waste Management Act, N.J.S.A. 13:1E-1 et seq., and the rules promulgated pursuant thereto, and in a manner which is acceptable to the administrative authority.

Amended by R.1994 d.469, effective September 19, 1994.
See: 26 N.J.R. 2715(a), 26 N.J.R. 3829(a).

APPENDIX A

FIGURES 1 THROUGH 26

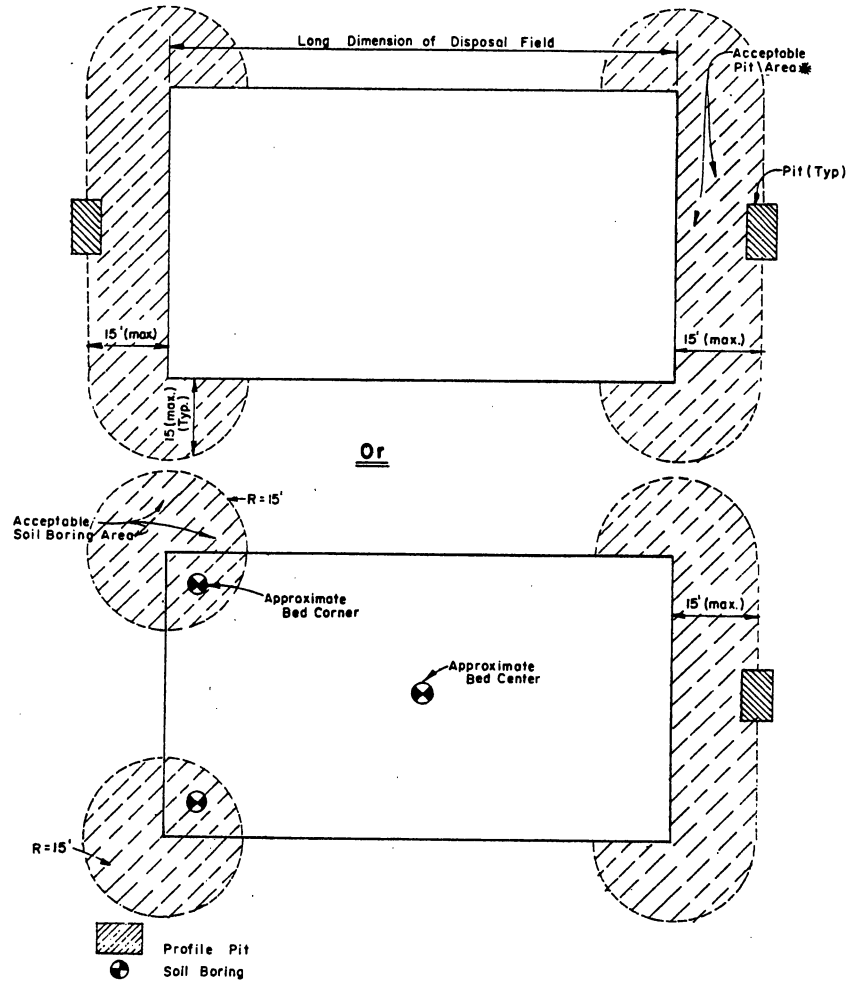

*Profile pits may be located within the boundaries of the disposal field also, provided that they are backfilled after use as prescribed in N.J.A.C. 7:9A-5.2(c).

Figure 1. Location of Soil Profile Pits and Borings

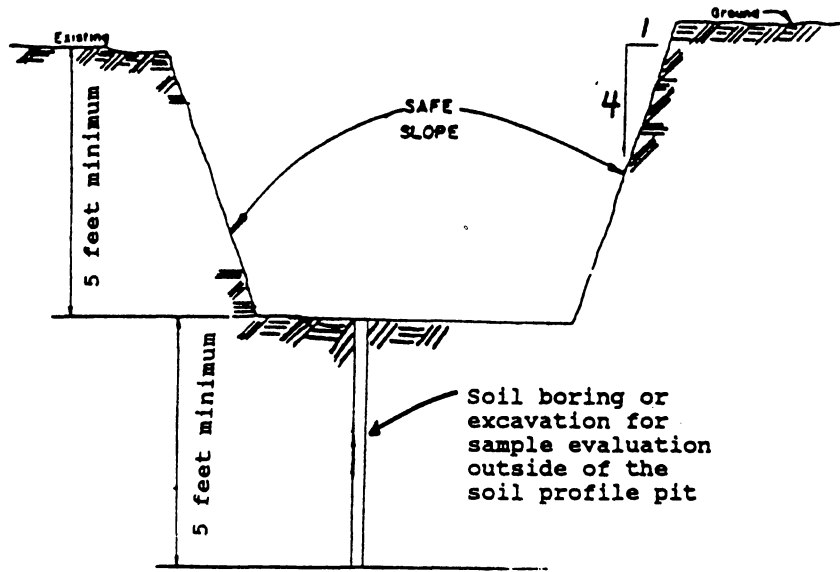
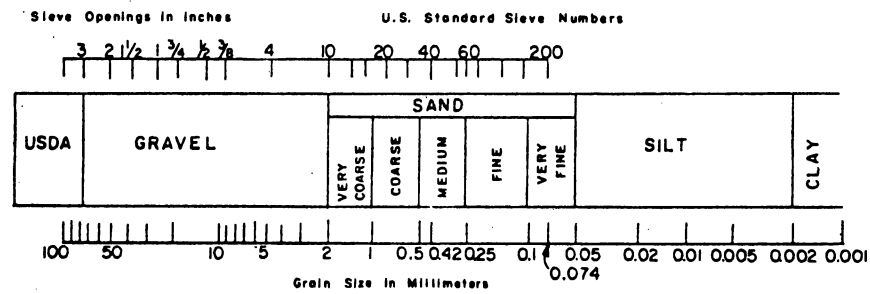
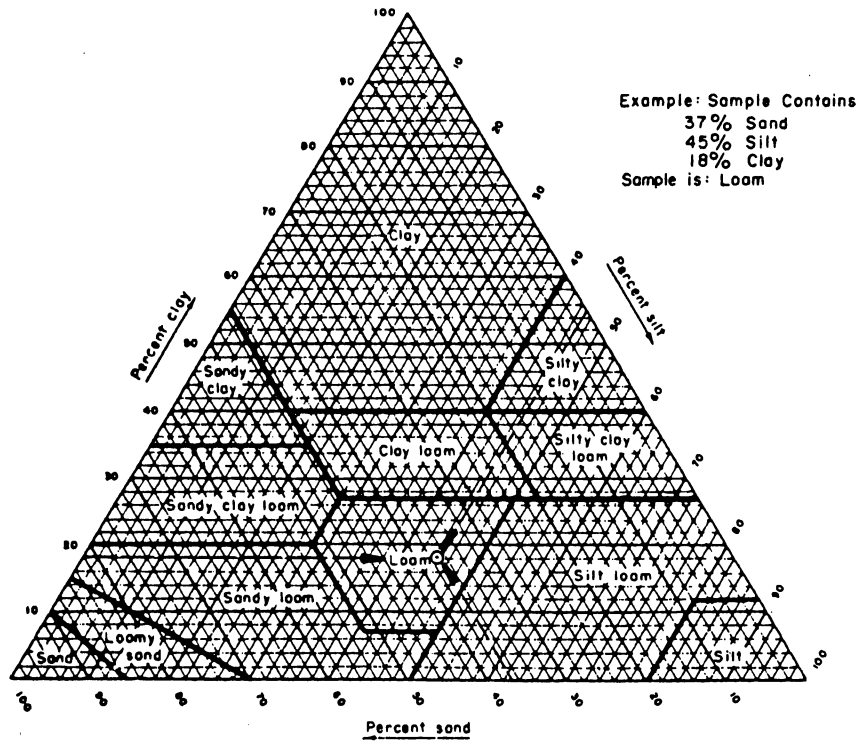
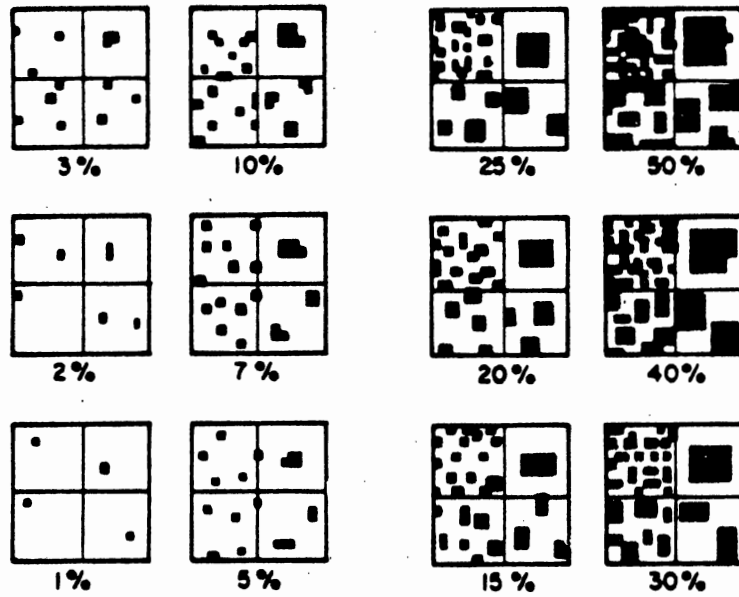

Figure 2. Recommended Cross-section of Soil Profile Pit.



Adapted from U.S. Dept. of the Interior, Water & Power Research Service (1974) *Earth Manual*, 2nd Edition, pg. 82

Figure 3. U.S.D.A. System of Soil Textural Classification



Charts for estimating proportions of Mottles and Coarse Fragments. Each fourth of any one square has the same amount of black.

Adapted from *Technical Manual for Sewage Enforcement Officers* Commonwealth of Pennsylvania, Dept. of Environmental Resources, Div. of Local Environmental Services, Bureau of Water Quality Management

Figure 4. Charts for Visual Estimation of Volume Percentage

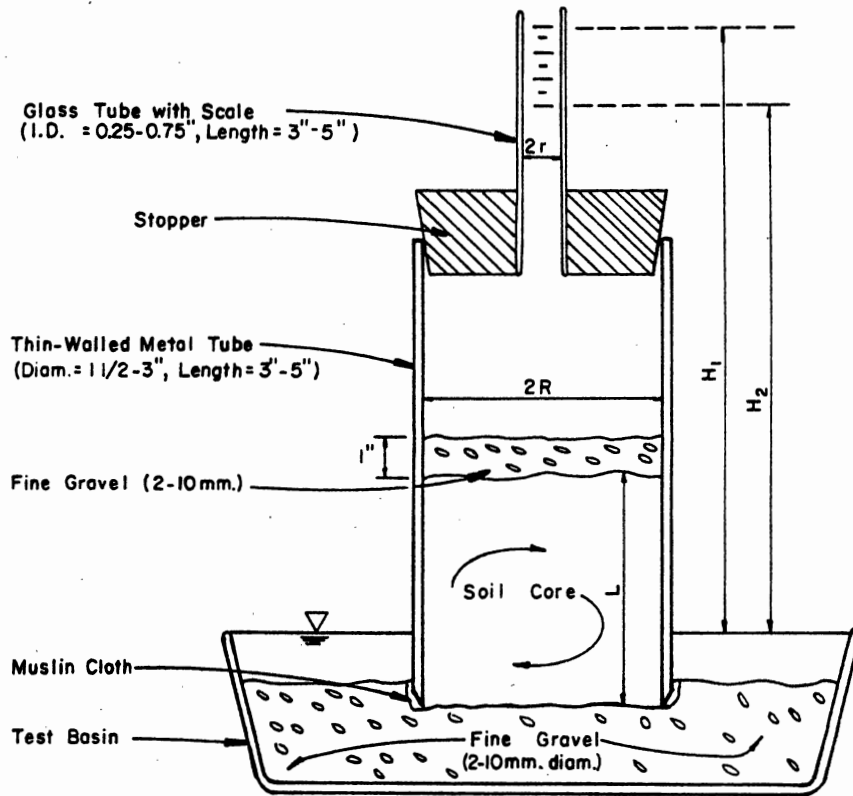

$$K(\text{in./hr.}) = 60(\text{min./hr.}) \times r^2/R^2 \times L(\text{in.})/T(\text{min.}) \times \ln(H_1/H_2)$$

Figure 5. Tube Permeameter (with standpipe)

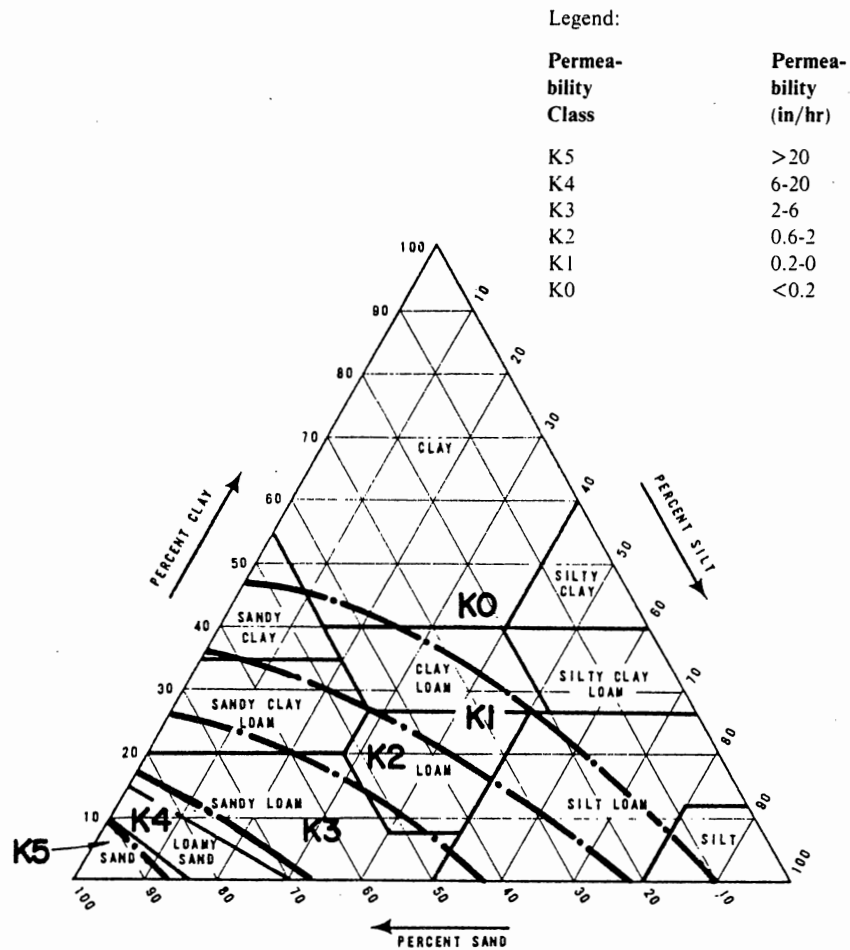

Adapted from N.N. Hantzche et al. (1982) Soil Textural Analysis for Onsite Sewage Disposal Evaluation, Proc. 3rd Nat. Symposium on Individual and Small Community Sewage Treatment, Am. Soc. Agric. Eng., St. Joseph, Michigan

Figure 6. Soil Permeability/Textural Triangle

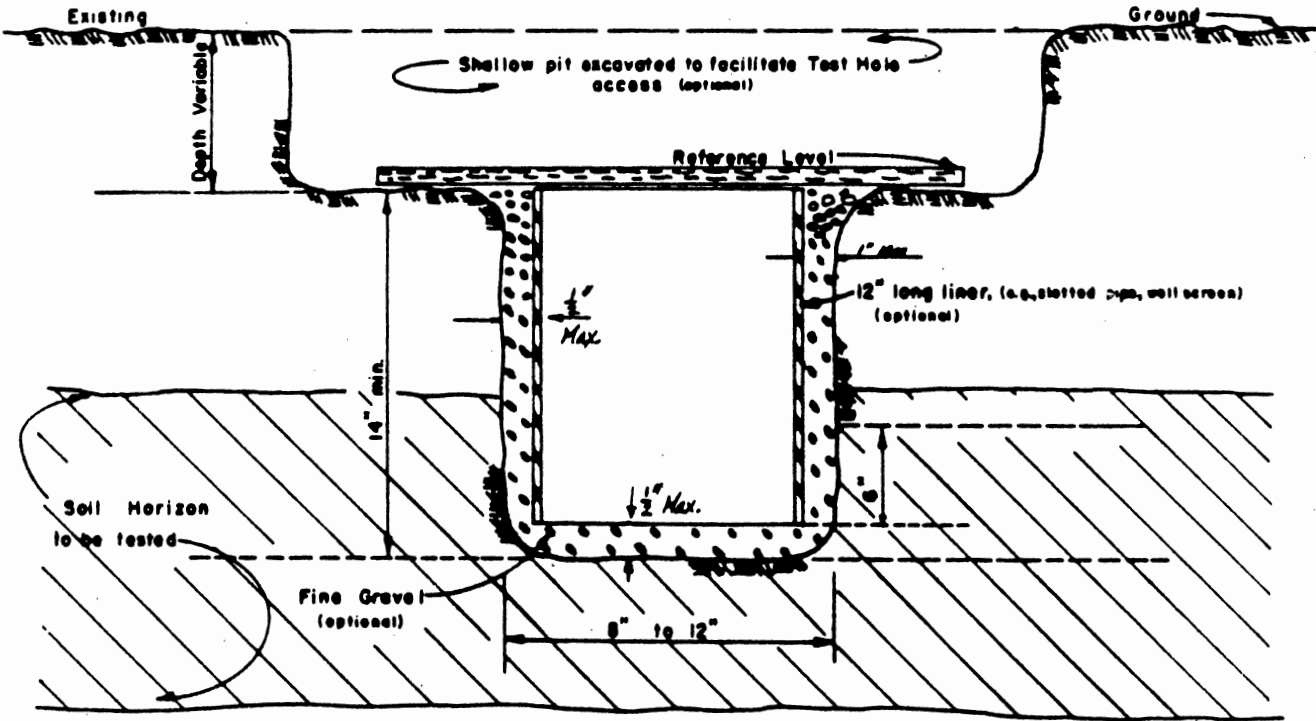
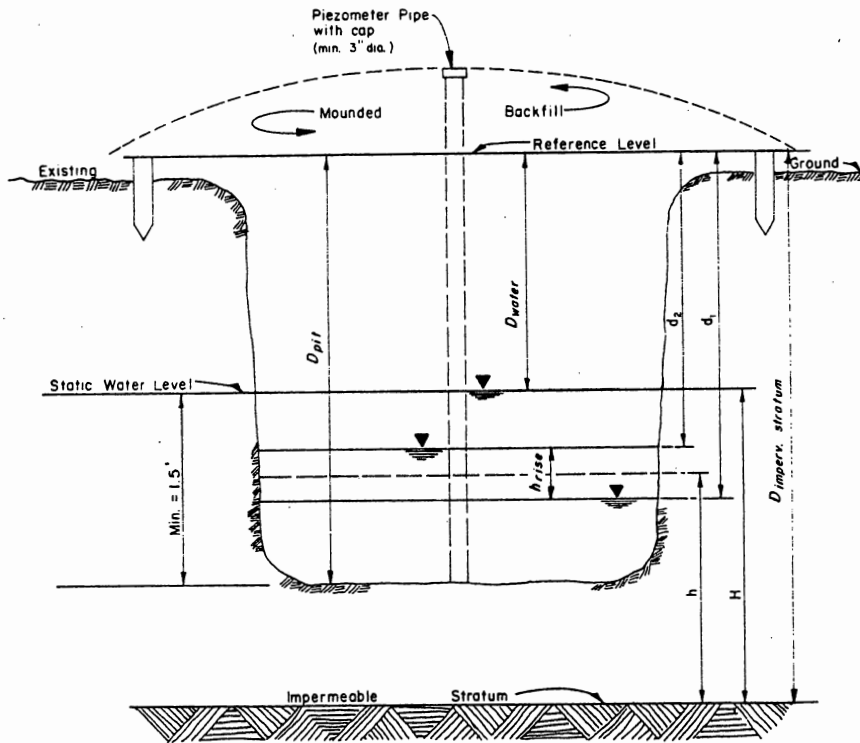
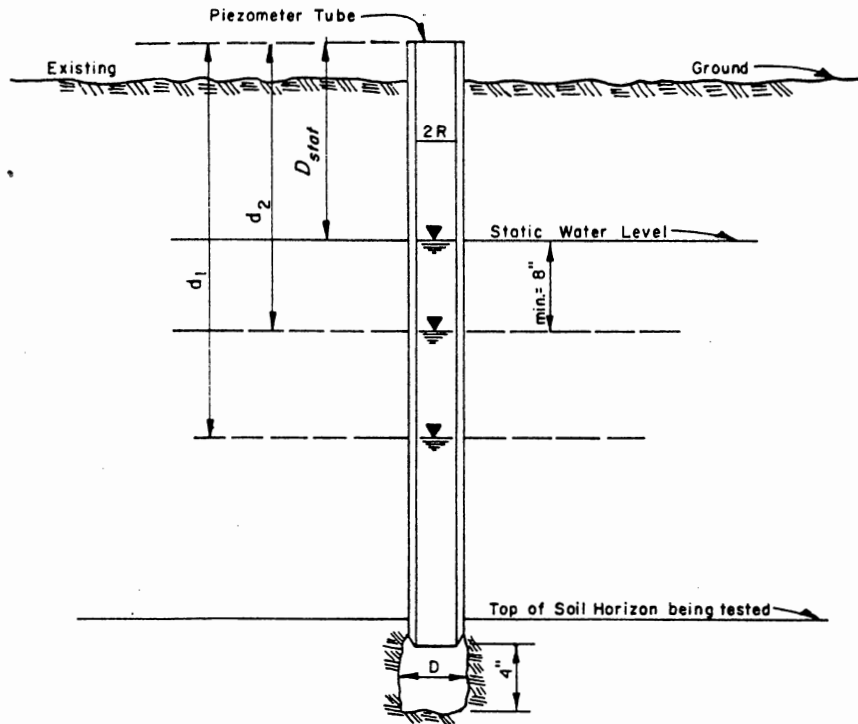

Figure 7. Percolation Test



$$K (\text{in./hr.}) = \left[\frac{(h \text{ rise})}{t} \right] \times \left[\frac{A_{\text{pit}}}{2.27 (H^2 - h^2)} \right] \times 60 \text{ min./hr.}$$

Figure 8. Pit-bailing Test.



$$K = 60 \text{ min/hr.} \times (3.14 R^2 / At) \times \ln [(d_1 - D_{stat}) / (d_2 - D_{stat})]$$

Figure 9. Piezometer Test.

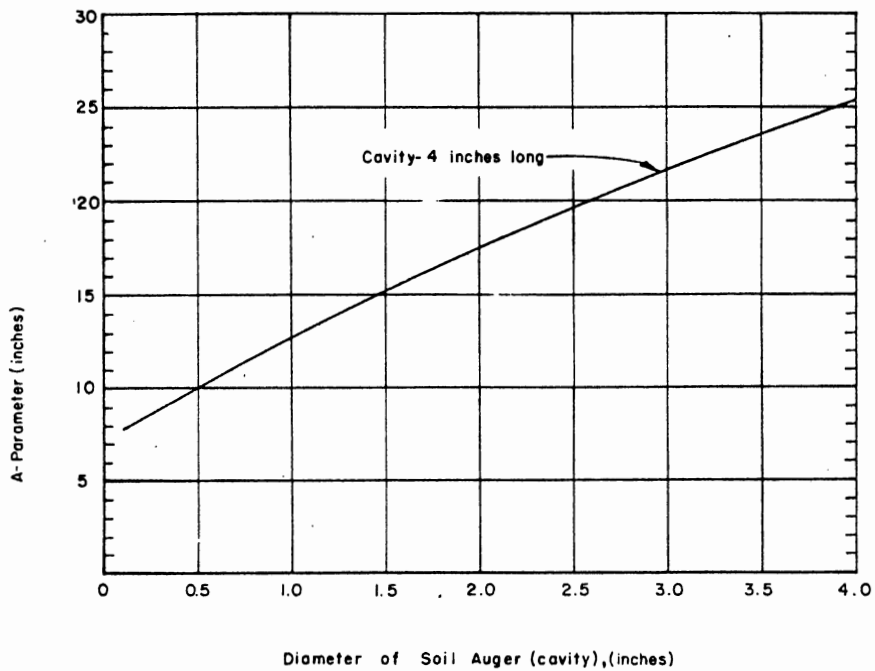
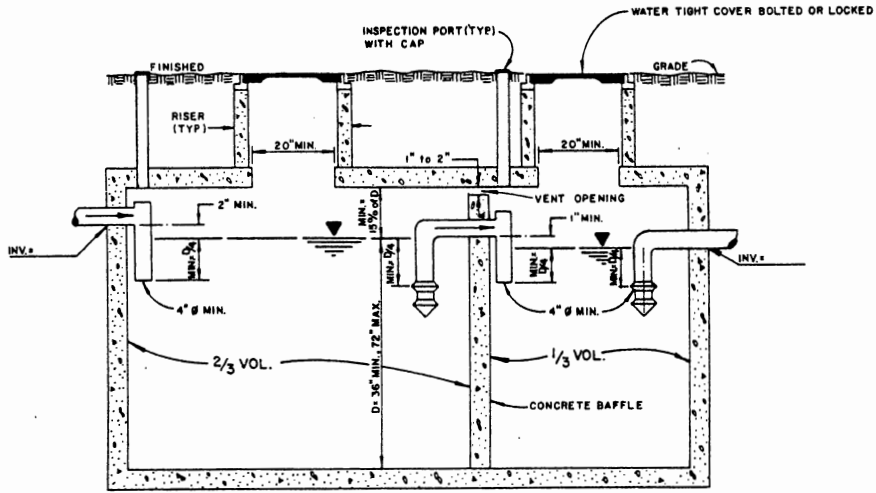
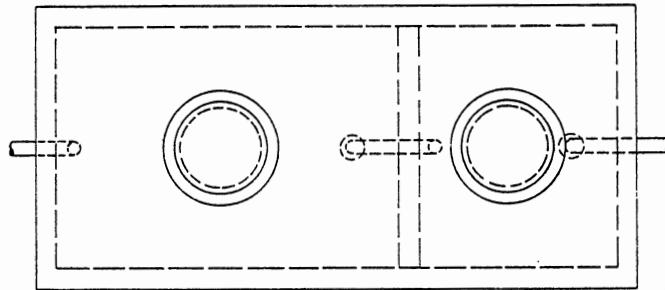

Figure 10. "A" Parameter for Piezometer Test.



ELEVATION

VOL. = TOTAL LIQUID CAPACITY



PLAN

Figure 11. Multiple Compartment Septic Tank with Septic Solids Retainer

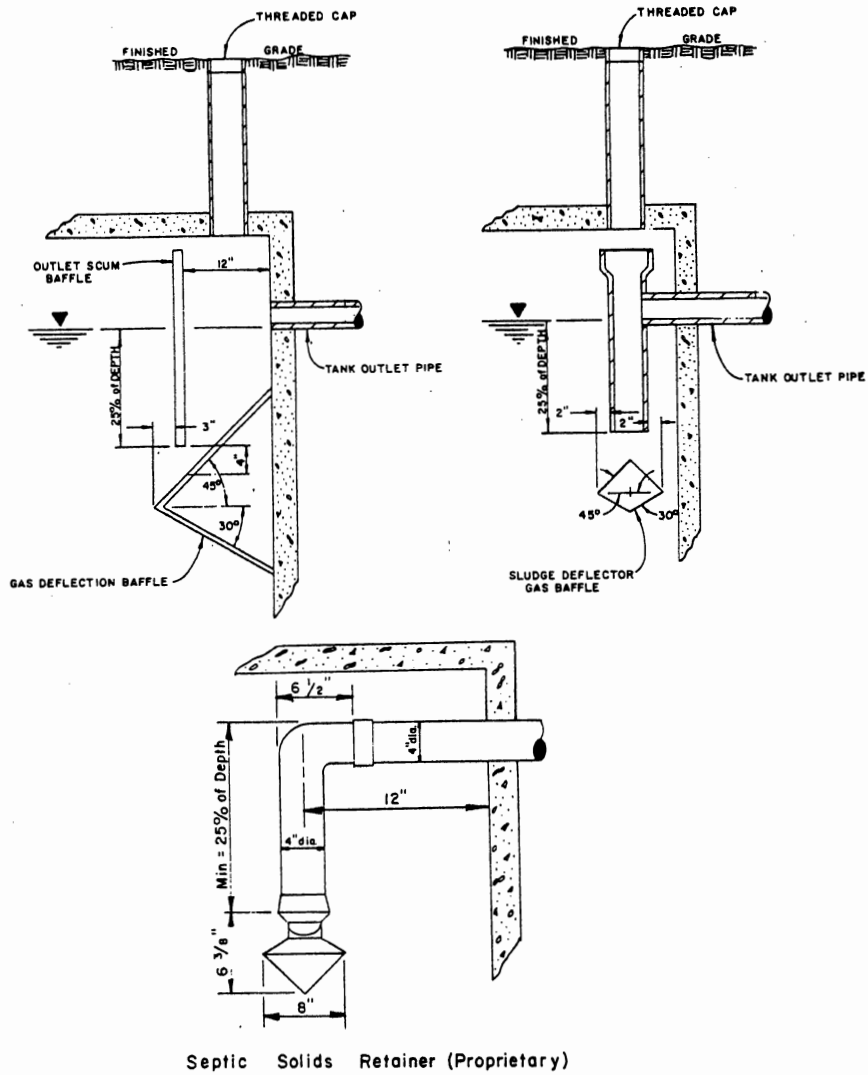
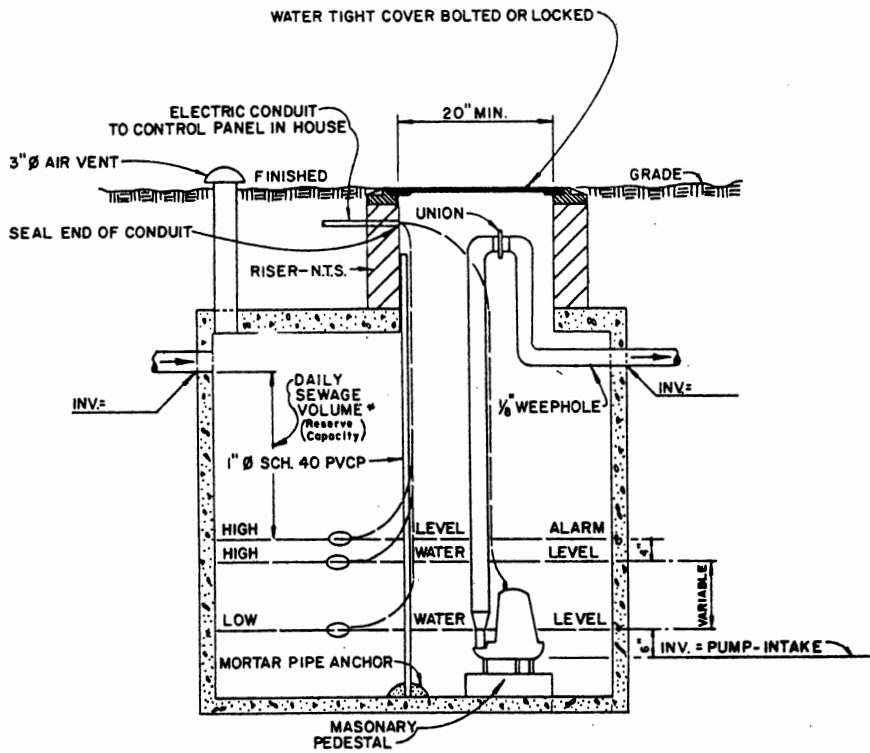

Figure 12. Gas Deflection Baffles



* Except where dual pumps used.

Figure 13. Dosing Tank with Pump.

LATERAL LENGTH (FT)	PIPES WITH 1/4 INCH HOLES				PIPES WITH 5/16 INCH HOLES				PIPES WITH 3/8 INCH HOLES			
	HOLE SPACING (FT)				HOLE SPACING (FT)				HOLE SPACING (FT)			
	2	3	4	5	2	3	4	5	2	3	4	5
10												
15							1				1	
20			1				1				1	
25									3/2	5/4		
30					3/2							
35							5/4					
40	3/2		5/4				3/2			2	3/2	
45					2							
50	2	3/2			3			3/2	3			

LATERAL LENGTH (FT)	PIPES WITH 7/16				PIPES WITH 1/2			
	HOLE SPACING (FT)				HOLE SPACING (FT)			
	2	3	4	5	2	3	4	5
10								
15				1				1
20	3/2		5/4			3/2	5/4	
25		3/2					3/2	
30			3/2					3/2
35				3/2			2	
40		2						
45					3			
50	3							

Computed for plastic pipe. The Hazen-Williams equation was used to compute head-losses through each pipe segment. (Hazen-Williams C = 150). The orifice equation for sharp-edged orifices (discharge coefficient = 0.6) was used to compute discharge rates through each orifice. The maximum lateral length for a given hole and spacing was defined as that length at which the difference between the rates of discharge from the distal end and the supply end orifices reached 10% of the distal orifice rate.

Figure 14. Required Lateral Diameters, in Inches, For Various Hole Diameters, Hole Spacings and Lateral Lengths

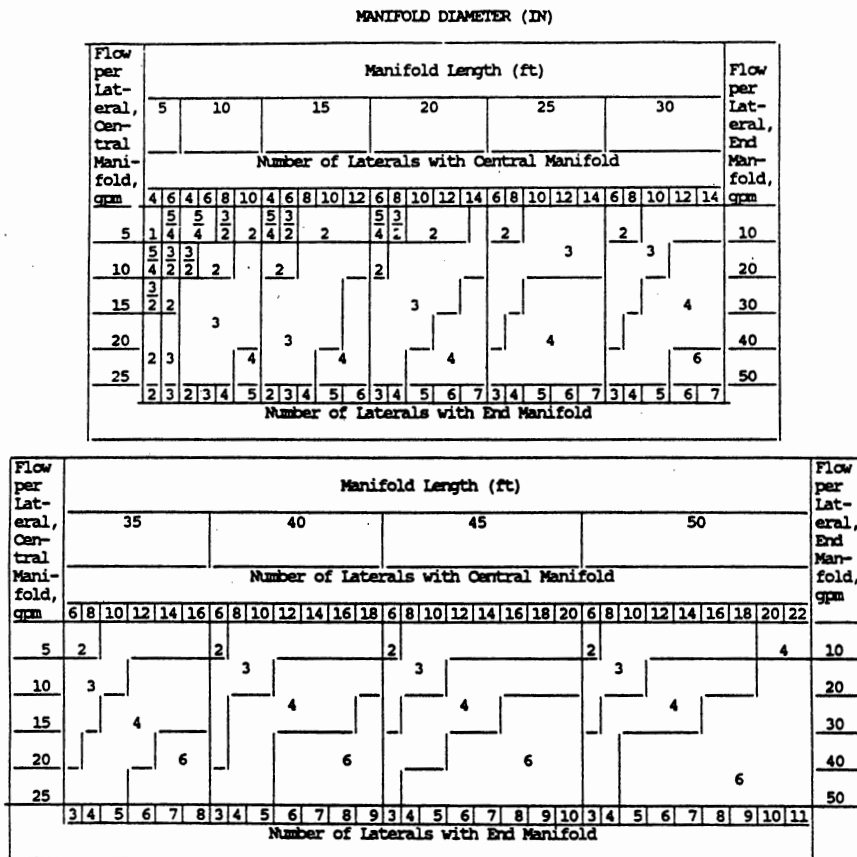

Figure 15. Required Manifold Diameters For Various Manifold Lengths, Number of Laterals and Lateral Discharge Rates

Computed for plastic pipe only. The Hazen-Williams equation was used to compute headlosses through each segment (Hazen-Williams C = 150). The maximum manifold length for given lateral discharge rate and spacing was defined as that length at which the difference between the heads at the distal and supply ends of the manifold reached 10 percent of the head at the distal end.

Figure 16 (Agency Note: Current Figure 16 in the New Jersey Administrative Code is proposed for deletion and replacement with proposed Figure 16 as shown below)

FRICTION LOSS IN SCHEDULE 40 PLASTIC PIPE, C = 150
(ft/100 ft)

Flow (gpm)	Pipe Diameter (in)									
	1	1¼	1½	2	2½	3	4	6	8	10
2
4	1.01
6	2.14	0.55
8	3.63	0.97	0.46
10	5.50	1.46	0.70	0.21
12	5.64	2.09	1.01	0.30	0.12
15	11.75	3.06	1.45	0.44	0.18	0.07
18	4.37	2.07	0.62	0.25	0.10
20	5.23	2.46	0.73	0.31	0.12
25	7.89	3.72	1.10	0.46	0.16
30	11.10	5.22	1.55	0.65	0.23
35	6.95	2.06	0.87	0.30	0.07
40	8.90	2.62	1.11	0.39	0.09
45	11.06	3.29	1.38	0.48	0.12
50	13.45	3.98	1.68	0.58	0.16
55	16.04	4.75	2.00	0.70	0.18
60	18.85	5.58	2.35	0.81	0.21
65	21.86	6.47	2.72	0.95	0.25
70	7.43	3.13	1.08	0.28
75	8.44	3.55	1.12	0.33
80	9.51	4.00	1.38	0.37
85	10.64	4.49	1.55	0.41
90	11.83	4.98	1.73	0.46
95	5.50	1.91	0.49
100	6.05	2.09	0.55	0.07
110	7.22	2.51	0.67	0.09
120	8.48	2.94	0.78	0.11
130	3.42	0.91	0.12
140	3.92	1.04	0.14
150	4.45	1.17	0.16
200	2.02	0.28	0.07
250	3.05	0.41	0.11
300	0.58	0.16
350	0.78	0.20	0.07
400	0.99	0.26	0.09
450	1.22	0.32	0.11
500	0.38	0.14
600	0.54	0.18
700	0.72	0.24
800	0.32
900	0.38
1000	0.46

Figure 16. Friction Loss in Schedule 40 Pipe

Amended by R.1993 d.294, effective June 21, 1993.
See: 24 N.J.R. 1987(a), 25 N.J.R. 2704(b).

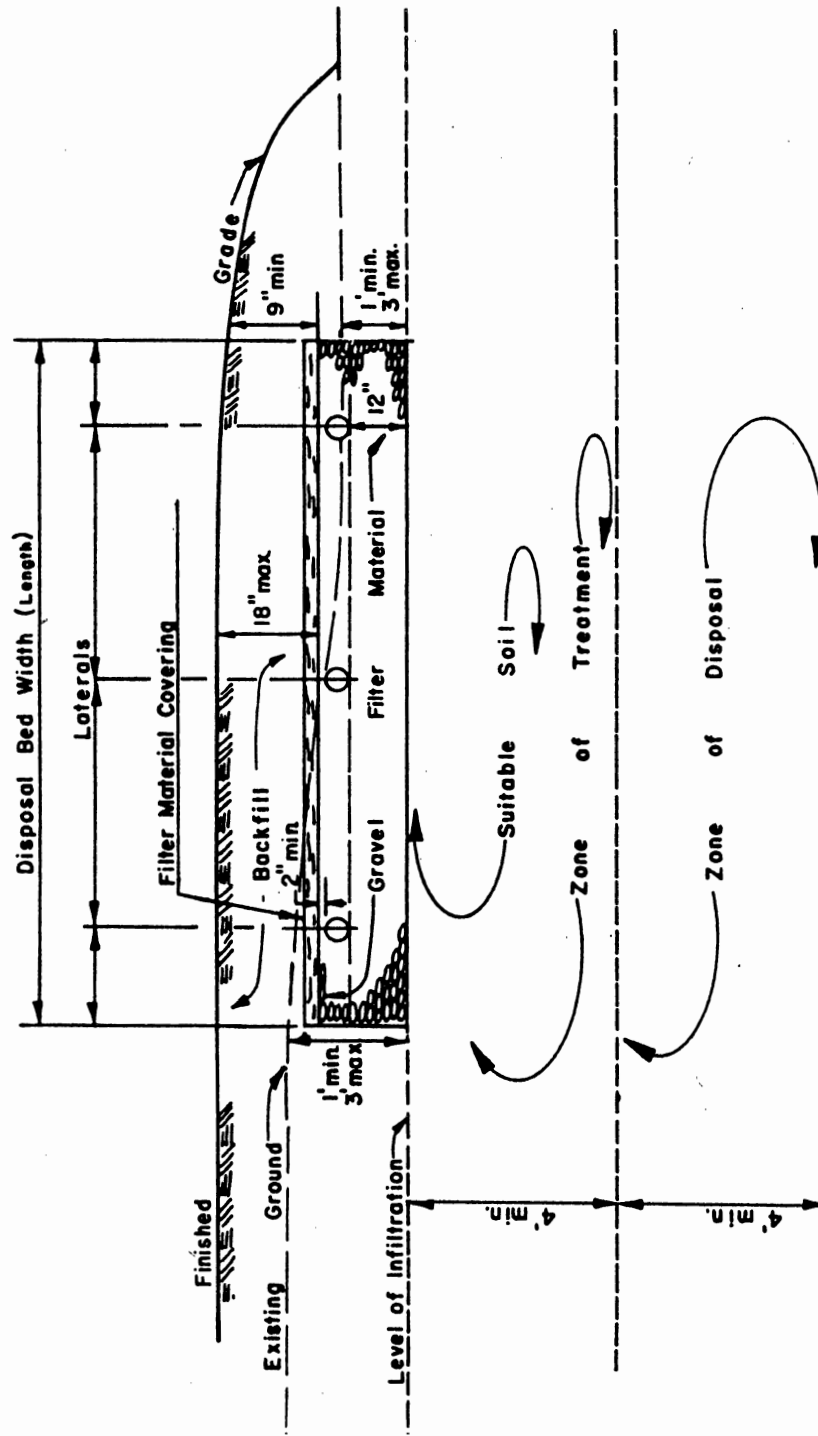

Figure 17. Conventional Disposal Field Installation.

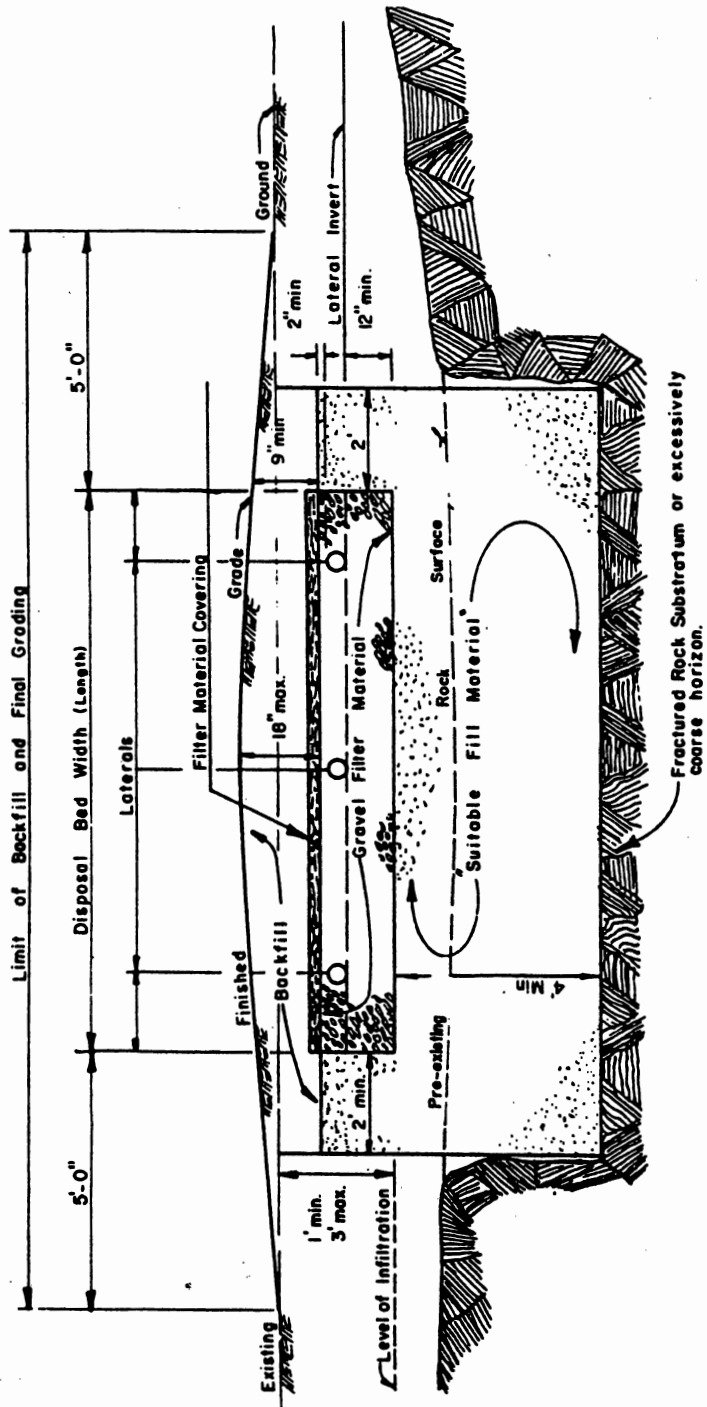

Figure 19. Soil Replacement, Fill-enclosed Disposal Field Installation.

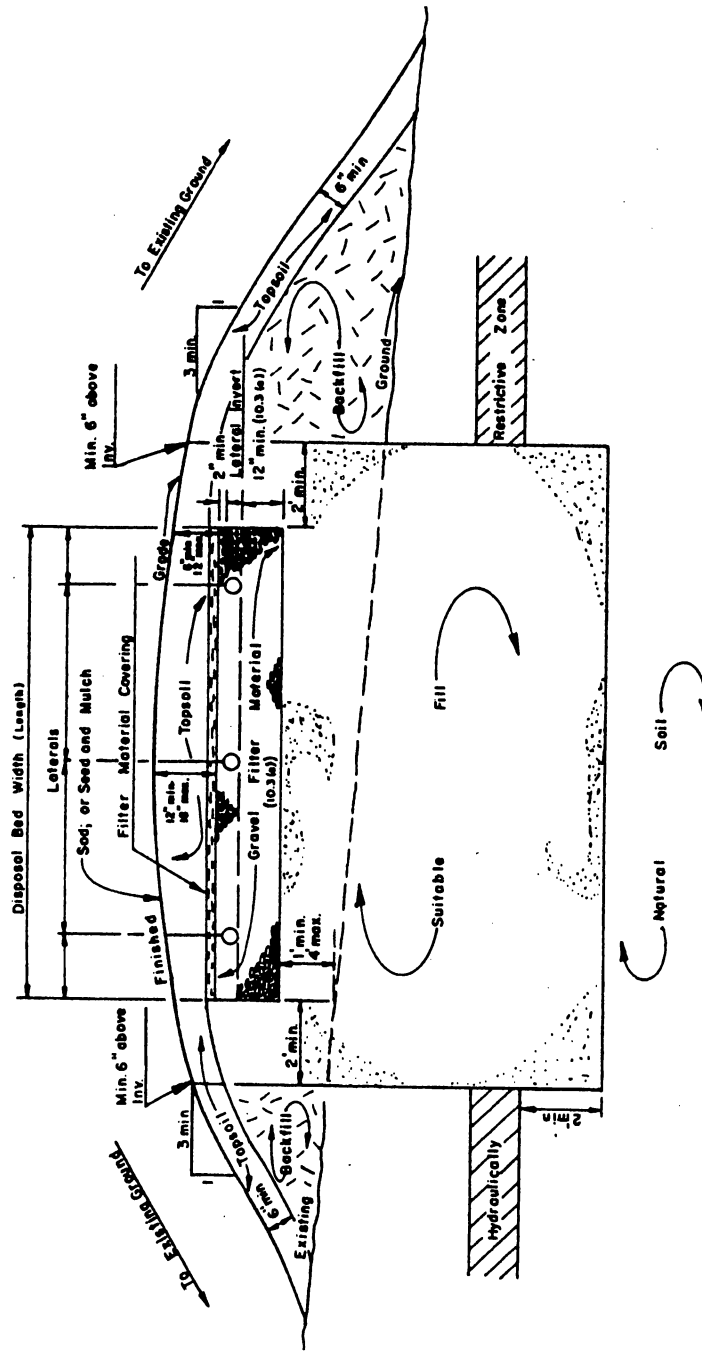

Figure 21. Mounded Soil Replacement Disposal Field Installation.

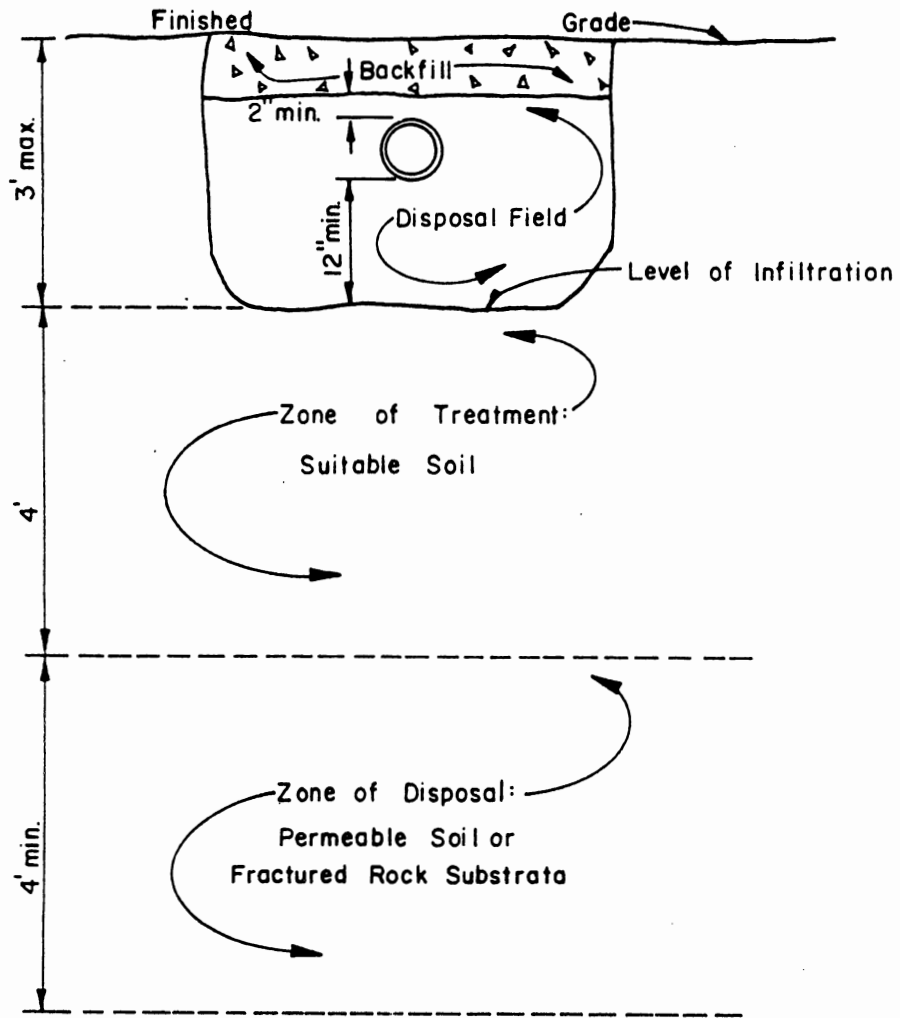

Figure 22. Zone of Treatment and zone of Disposal, Conventional Installations.

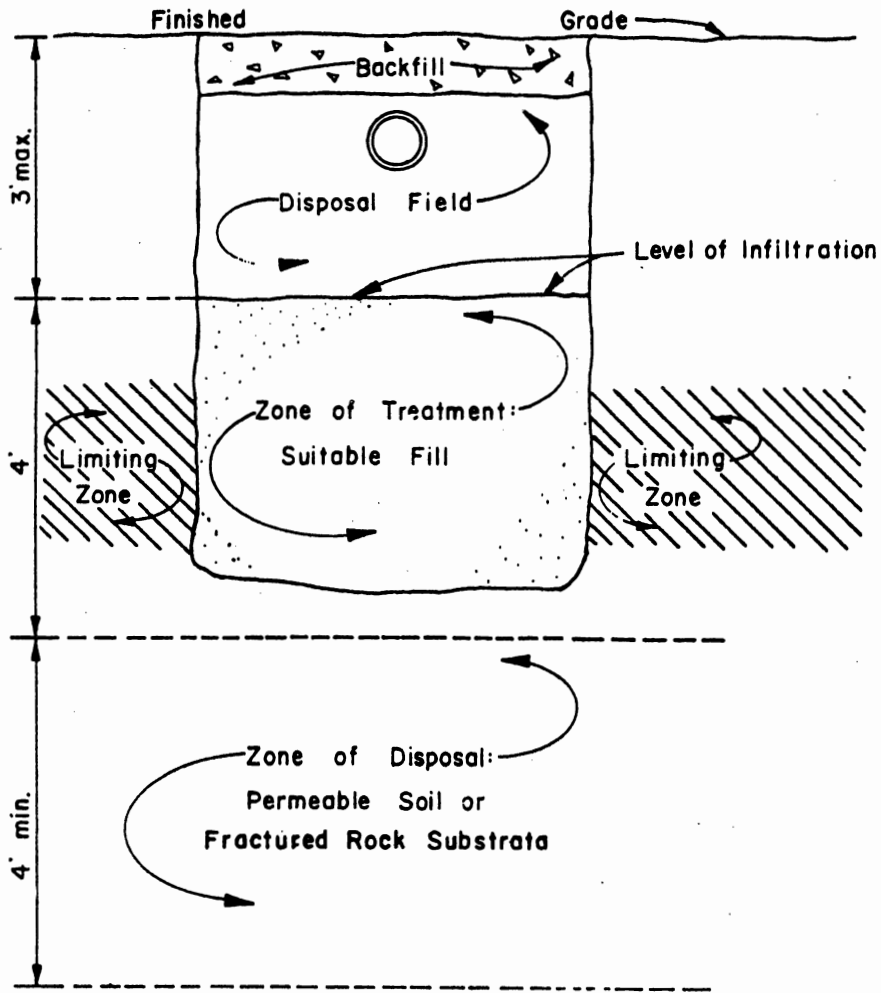

Figure 23. Placement of Fill Material Within Zone of Treatment.

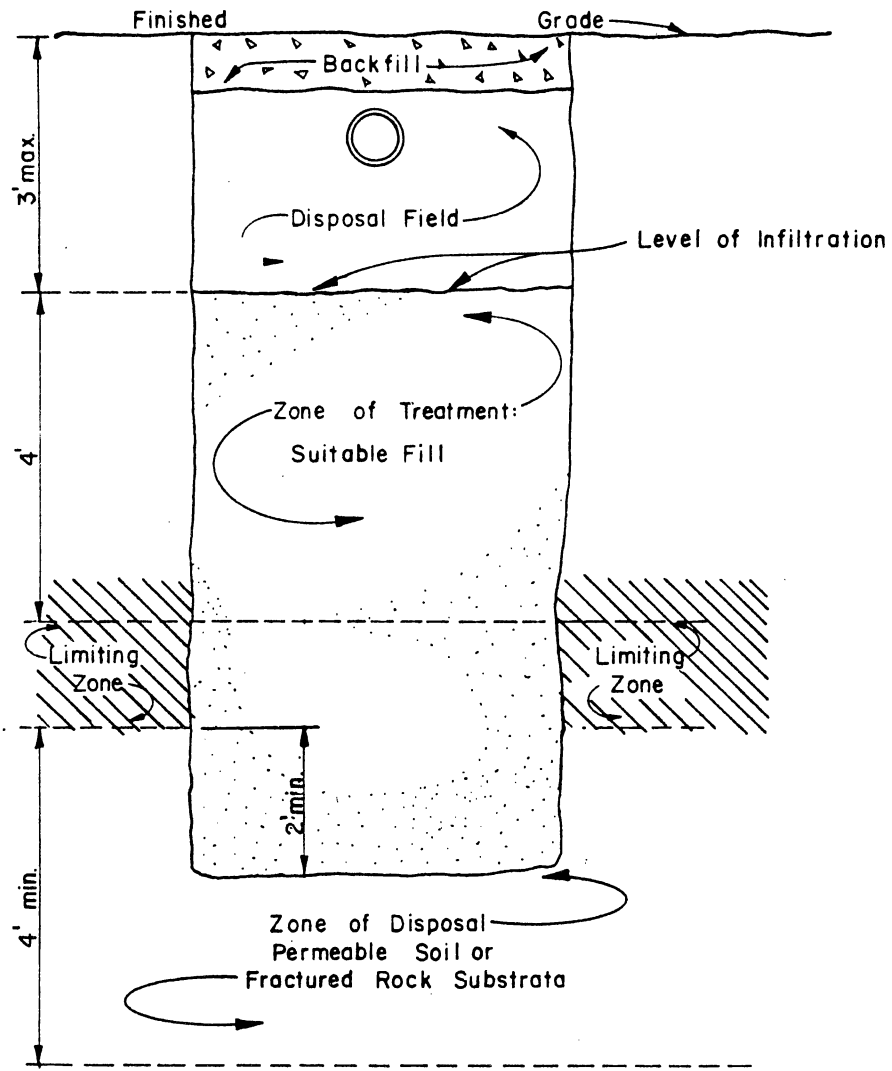

Figure 24. Placement of Fill Material Within Zone of Disposal.

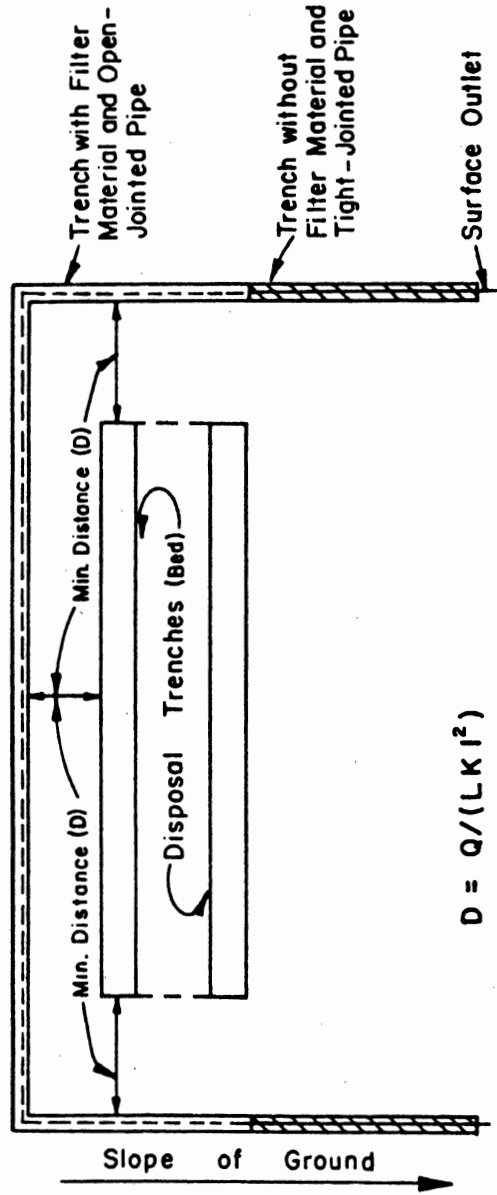

Figure 25. Disposal Field with Interceptor Drain.

Size Number	Nominal Size Square Openings (I)	Amounts finer than each laboratory sieve (square openings), percentage by weight															
		4	3½	3	2½	2	1½	1	¾	½	¼	No. 4	No. 8	No. 16	No. 50	No. 100	
1	3½ to 1½	100	90-100		25-60		0-15		0-5								
2	2½ to 1½			100	90-100	35-70	0-15		0-5								
24	2½ to ¾			100	90-100	25-60	0-10		0-5								
3	2 to 1				90-100	35-70	0-15		0-5								
357	2 to No. 4				100	95-100	35-70		10-30		0-5						
4	1½ to ¾					90-100	20-55		0-15		0-5						
467	1½ to No. 4					95-100	35-70		10-30		0-5						
5	1 to ½					90-100	20-55		0-10		0-5						
56	1 to ¾					90-100	40-75		15-35		0-5						
57	1 to No. 4					95-100	25-60		10-30		0-5		0-5				
6	¾ to ½					90-100	20-55		0-15		0-5						
67	¾ to No. 4					90-100	20-55		0-10		0-5		0-5				
68	¾ to No. 8					90-100	30-65		10-25		0-5		0-10				
7	½ to No. 4					90-100	40-75		15-35		0-5		0-10				
78	½ to No. 8					90-100	40-75		15-35		0-5		0-10				
8	½ to No. 8					90-100	40-75		15-35		0-5		0-10				
89	½ to No. 16					90-100	30-65		10-25		0-5		0-10		0-5		
9	No. 4 to No. 16					90-100	55-100		10-30		0-5		0-10		0-5		
10	No. 4 to 0'					90-100	85-100		10-40		0-5		0-10		0-5		10-30

*In inches, except where otherwise indicated. Numbered sieves are those of the United States Sieve Series.
 *Screenings.

Figure 26. N.J. Department of Transportation Standard Sizes for Coarse Aggregate

APPENDIX B

STANDARD FORMS FOR
 SUBMISSION OF SOILS/ENGINEERING DATA
 COUNTY/MUNICIPALITY _____

APPLICATION FOR PERMIT TO CONSTRUCT/ALTER/REPAIR
 AN INDIVIDUAL SUBSURFACE SEWAGE DISPOSAL SYSTEM

Form 1—General Information

- Type of Permit Needed (Check applicable categories):
 New Construction Alteration/No Expansion or Change of Use
 Alteration/Expansion or Change in Use
 Alteration/Malfunctioning System
 Deviation from Standards Repairs to Existing System
- Location of Project:
 Municipality _____ Block No. _____ Lot No. _____
 Street Address _____ Zip _____
- Name of Applicant (print): _____
- Applicant's Present Address: _____
- Applicant's Phone Number: _____
- Type Of Facility:
 Residential
 Commercial/Institutional
 Specify Type of Establishment: _____
- Type of Wastes to be Discharged:
 Sanitary Sewage
 Industrial Wastes
 Other—Specify Type _____
- Other Approvals/Certification/Waivers/Exemptions (Attach to Application):
 Pinelands Commission
 U.S. Army Corps of Engineers
 NJDEP—Bureau of Flood Plain Management
 Other—Specify: _____
- I hereby certify that the information furnished on Form 1 of this application is true. I am aware that false swearing is a crime in this State and subject to prosecution.
 Signature of Applicant _____ Date _____

FOR AGENCY USE ONLY

Application Denied—Reason for Denial/Citation of Rules Violated: _____

Application Approved
 Application Approved Subject to Approval by NJDEP
 Date of Action _____ Signature of Authorized Agent _____
 Name and Title _____
 COUNTY/MUNICIPALITY _____

APPLICATION FOR PERMIT TO CONSTRUCT/ALTER/REPAIR
 AN INDIVIDUAL SUBSURFACE SEWAGE DISPOSAL SYSTEM

- Form 2a—General Site Evaluation Data Lot _____ Block _____
- Name of Site Evaluator (print): _____
 - Business Address of Site Evaluator: _____
 - Business Phone Number of Site Evaluator: _____
 - Special Site Limitations Identified (Check appropriate Categories):
 Flood Plains Bedrock Outcrops Wetlands
 Excessively Stony Disturbed Ground Sink Holes
 Sand Dunes Steep Slopes
 Other—Specify _____
 - Soil Logs—Enter on Form 2b—Use one sheet for each soil log.
 - Considerations Relating to Disturbed Ground:
 a) Type of Disturbance (Check appropriate categories):
 Filled Area Excavated Area Re-graded Area
 Subsurface Drains Other—Specify _____
 b) Pre-existing Natural Ground Surface
 Elevation Relative to Existing Ground Surface _____
 Method of Identification _____
 c) Suitability of Disturbed Ground
 Unsuitable: Objects Subject to Disintegration or Change in Volume
 Excessively Coarse
 Proctor Test performed—% Standard Proctor Density = _____
 - Hydraulic Head Test:
 a) Hydraulically Restrictive Horizon: Depth Top to Bottom _____
 b) Piezometer A: Depth to Bottom _____ Depth of Water Level (24 hrs) _____
 c) Piezometer B: Depth to Bottom _____ Depth of Water Level (24 hrs) _____
 d) Witnessed by _____ Signature _____ Date _____
 - Attachments (Check items included):
 Site Plan
 Key Map Showing Location of Site On U.S.G.S. Quadrangle or Other Accurate Map
 Key Map Showing Location of Site on U.S.D.A. Soil Survey Map
 Other—Specify _____

9. I hereby certify that the information furnished on Form 2a of this application (and the attachments thereto) is true and accurate. I am aware that falsification of data is a violation of the Water Pollution Control Act (N.J.S.A. 58:10A-1 et seq.) and is subject to penalties as prescribed in N.J.A.C. 7:14-8.

Signature of Soil Evaluator _____ Date _____
Signature of Professional Engineer _____ License # _____
COUNTY/MUNICIPALITY _____

APPLICATION FOR PERMIT TO CONSTRUCT/ALTER/REPAIR AN INDIVIDUAL SUBSURFACE SEWAGE DISPOSAL SYSTEM

Form 2b—Soil Log and Interpretation Lot _____ Block _____
1. Log Number _____ Method (Check One): _____ Profile Pit _____ Boring
2. Soil Log
Depth _____ Munsel Color Name and Symbol; Estimated Textural Class:
(inches) Estimated Volume % Coarse Fragment, If Present; Structure;
Top-Bottom Moist or Dry Consistence; Mottling—Abundance, Size and Contrast, If Present

- 3. Ground Water Observations:
Seepage—Indicate Depth _____
Pit/Boring Flooded—Depth after _____ Hours _____
4. Soil Limiting Zones (Check Appropriate Categories):
Fractured Rock Substratum—Depth to Top _____
Massive Rock Substratum—Depth to Top _____
Excessively Coarse Horizon—Depth Top to Bottom _____
Excessively Coarse Substratum—Depth to Top _____
Hydraulically Restrictive Horizon—Depth Top to Bottom _____
Hydraulically Restrictive Substratum—Depth to Top _____
Perched Zone of Saturation—Depth Top to Bottom _____
Regional Zone of Saturation—Depth to Top _____
5. Soil Suitability Classification:
6. I hereby certify that the information furnished on Form 2b of this application is true and accurate. I am aware that falsification of data is a violation of the Water Pollution Control Act (N.J.S.A. 58:10A-1 et seq.) and is subject to penalties as prescribed in N.J.A.C. 7:14-8.

Signature of Site Evaluator _____ Date _____
Signature of Professional Engineer _____ License # _____
COUNTY/MUNICIPALITY _____

APPLICATION FOR PERMIT TO CONSTRUCT/ALTER/REPAIR AN INDIVIDUAL SUBSURFACE SEWAGE DISPOSAL SYSTEM

Form 3a. Soil Permeability Data Lot _____ Block _____
Assign a number for each test and a letter for each test replicate. Show test data and calculations on Form 3b, 3c, 3d, 3e, 3f or 3g. Use one sheet for each separate test or test replicate.

1. Summary of Data—Enter data for each test replicate on a separate line.

Table with 5 columns: Type of Test, Test (number), Replicate (letter), Depth (inches), Result*. Multiple rows for data entry.

* For tube permeameter, pit-bailing and piezometer tests report results in inches per hour. For Soil permeability class rating give soil permeability class number. For percolation test report result in minutes per inch. For basin flooding test report result as positive if basin drains completely within 24 hours after second filling, negative otherwise.

2. Design Permeability/Percolation Rate: Specify Test Number _____
Average of Test Replicates _____ Single Replicate _____
Slowest of Replicates _____

3. Type of Limiting Zone Identified _____ Test Number _____

- 4. Attachments (Check items included):
Form 3b—Tube Permeameter Test Data—Number of Sheets _____
Form 3c—Soil Permeability Class Rating Test Data—Number of Sheets _____
Form 3d—Percolation Test Data—Number of Sheets _____
Form 3e—Pit-Bailing Test Data—Number of Sheets _____
Form 3f—Piezometer Test Data—Number of Sheets _____
Form 3g—Basin Flooding Test Data—Number of Sheets _____

5. I hereby certify that the information furnished on Form 3a of this application (and the attachments thereto) is true and accurate. I am aware that falsification of data is a violation of the Water Pollution Control Act (N.J.S.A. 58:10A-1 et seq.) and is subject to penalties as prescribed in N.J.A.C. 7:14-8.

Signature of Soil Evaluator _____ Date _____
Signature of Professional Engineer _____ License # _____

Form 3b. Tube Permeameter Test Data

- 1. Test Number _____ Replicate (Letter) _____ Date Collected _____
2. Material Tested: _____ Fill _____ Test in Native Soil—Indicate Depth _____
3. Type of Sample: _____ Undisturbed _____ Disturbed _____
4. Sample Dimensions: Inside Radius of Sample Tube, R, in cm. _____
Length of Sample, L, in inches _____
5. Bulk Density Determination (Disturbed Samples Only):
Sample Weight (Wt. Tube Containing Sample—Wt. of Empty Tube), grams _____

Sample Volume (L x 2.54cm./inch x 3.14R^2), cc. _____
Bulk Density (Sample Wt./Sample Volume), grams/cc. _____

- 6. Standpipe Used: _____ No _____ Yes
—Indicate Internal Radius, cm. _____
7. Height of Water Level Above Rim of Test Basin, in inches:
At the Beginning of Each Test Interval, H1 _____
At the End of Each Test Interval, H2 _____
8. Rate of Water Level Drop (Add additional lines if needed):

Table with 3 columns: Time, Start of Test Interval, T1; Time, End of Test Interval, T2; Length of Test Interval, T, minutes. Multiple rows for data entry.

- 9. Calculation of Permeability:
K, (in/hr) = 60 min/hr x r^2/R^2 x L(in)/T(min) x ln (H1/H2)
= 60 min/hr x _____ / _____ x _____ / _____
x ln (_____ / _____) = _____
10. Defects in the Sample (Check appropriate items):
None _____ Cracks _____ Worm Channels _____
Root Channels _____ Soil/Tube Contact _____
Large Gravel _____ Large Roots _____
Dry Soil _____ Smearing _____ Compaction _____
Other—Specify _____
11. I hereby certify that the information furnished on Form 3b of this application is true and accurate. I am aware that falsification of data is a violation of the Water Pollution Control Act (N.J.S.A. 58:10A-1 et seq.) and is subject to penalties as prescribed in N.J.A.C. 7:14-8.

Signature of Site Evaluator _____ Date _____
Signature of Professional Engineer _____ License # _____

Form 3c. Soil Permeability Class Rating Data

- 1. Test Number _____ Replicate (Letter) _____
2. Sample Depth _____ Soil Pit/Boring Number _____ Date Collected _____
3. Coarse Fragment Content:
Total Weight of Sample, W.T., grams _____
Weight of Material Retained on 2mm sieve, W.C.F., grams _____
Wt. % Coarse Fragment (W.C.F./W.T. x 100): _____
4. Oven Dry Weight (24 hrs., 105°C) of 40 Gram Air Dry Sample, grams, Wt _____

- 5. Hydrometer Calibration, Rc _____
6. Hydrometer Reading—40 seconds, grams, R1 _____
Temperature of Suspension, °F _____
7. Corrected Hydrometer Reading, grams, R1' _____
8. Hydrometer Reading—2 hours, grams, R2 _____
Temperature of Suspension, °F _____
9. Corrected Hydrometer Reading, grams, R2' _____
10. % sand = (Wt. - R1')/Wt. x 100 = (_____ - _____) / _____ x 100 = _____
11. % clay = R2'/Wt. x 100 = _____ / _____ x 100 = _____
12. Sieve Analysis:

- a. Oven Dry Wt. (2 hrs., 105°C) Total Sand Fraction (Soil Retained in 0.075 mm Sieve), grams _____
b. Wt. of Fine Plus Very Fine Sand Fraction (Sand Passing 0.25 mm Sieve), grams _____
c. % Fine Plus Very Fine Sand (b/a) _____

- 13. Soil Morphology (Natural Soil Samples Only):
Structure of Soil Horizon Tested _____
Consistence of Soil Horizon Tested: Dry _____ Moist _____
14. Soil Permeability Class Rating (Based upon average textural analysis of this replicate and other replicate samples) _____
15. I hereby certify that the information furnished on Form 3c of this application is true and accurate. I am aware that falsification of data is a violation of the Water Pollution Control Act (N.J.S.A. 58:10A-1 et seq.) and is subject to penalties as prescribed in N.J.A.C. 7:14-8.

Signature of Site Evaluator _____ Date _____

Signature of Professional Engineer _____ License # _____

Form 3d. Percolation Test Data

1. Test Number _____ Replicate (Letter) _____ Date Tested _____
2. Depth _____
3. Pre-soak:
 - Sandy Textured Soil Only, Shortened Pre-soak—Indicate Time Required for 12 Inches of Water to Drain After Second Filling, Minutes _____
 - Four Hour Pre-soak Completed—Indicate Result:
 - _____ Test Hole Drained Within 16 to 24 Hours After Pre-soak
 - _____ Test Hole Did Not Drain Within 24 Hours After Pre-soak

4. Rate of Fall Data:
 - a. Time Interval Selected, Minutes _____
 - b. Record the Drop in Water Level During Each Time Interval to the Nearest 1/10th-Inch On the Lines Below:

Depth of Water, Start of Interval (inches)	Depth of Water, End of Interval (inches)	Drop in Water Level (inches)
_____	_____	_____
_____	_____	_____
_____	_____	_____
_____	_____	_____
_____	_____	_____
_____	_____	_____
_____	_____	_____
_____	_____	_____
_____	_____	_____
_____	_____	_____

5. Percolation Rate:
 - a. Time, minutes, Required for a Six-inch Drop in Water Level _____
 - b. Percolation Rate = $a/6 = \frac{\quad}{6} = \quad$ min/in
6. I hereby certify that the information furnished on Form 3d of this application is true and accurate. I am aware that falsification of data is a violation of the Water Pollution Control Act (N.J.S.A. 58:10A-1 et seq.) and is subject to penalties as prescribed in N.J.A.C. 7:14-8.

Signature of Site Evaluator _____ Date _____

Signature of Professional Engineer _____ License # _____

Form 3e. Piezometer Test Data

1. Test Number _____ Reference Soil Log _____ Date Tested _____
2. Diameter of Soil Auger, in. _____ Depth of Test Hole, in. _____ Inside Radius of Pipe, R, in. _____
3. Depth to Apparent Static Water Level, in. _____
4. Measure and Record:

Water Depth, Start of Interval inches, d ₁	Time at Start of Interval	Water Depth, End of Interval inches, d ₂	Time at End of Interval	Length of Interval, min, t
_____	_____	_____	_____	_____
_____	_____	_____	_____	_____
_____	_____	_____	_____	_____
_____	_____	_____	_____	_____
_____	_____	_____	_____	_____
_____	_____	_____	_____	_____
_____	_____	_____	_____	_____
_____	_____	_____	_____	_____
_____	_____	_____	_____	_____
_____	_____	_____	_____	_____

5. Depth to Water Level After 24 Hour Stabilization Period, D_{static} in. _____
6. Value of A-parameter _____
7. Calculation of Permeability:

$$K, \text{ in/hr} = \left[\frac{(3.14R^2)}{(A \times t)} \right] \times \left[\frac{\ln(d_1 - D_{stat}/d_2 - D_{stat})}{\ln(d_1 - D_{stat}/d_2 - D_{stat})} \right] \times 60 \text{ min/hr} = \left[\frac{(3.14 \quad)}{(\quad \times \quad)} \right] \times \left[\frac{\ln(\quad - \quad / \quad - \quad)}{\ln(\quad - \quad / \quad - \quad)} \right] \times 60 \text{ min/hr} = \quad$$
8. I hereby certify that the information furnished on Form 3e of this application is true and accurate. I am aware that falsification of data is a violation of the Water Pollution Control Act (N.J.S.A. 58:10A-1 et seq.) and is subject to penalties as prescribed in N.J.A.C. 7:14-8.

Signature of Site Evaluator _____ Date _____

Signature of Professional Engineer _____ License # _____

Form 3f. Pit-Bailing Test Data

1. Test Number _____ Reference Soil Log _____ Date Tested _____
2. Using the reference level established, measure and record the following:
 - Depth to Bottom of Pit, ft, D_{pit} _____
 - Depth to Water Level after 2 hr. Stabilization Period, ft, D_{water} _____
 - Depth to Impermeable Stratum, ft, D_{stratum} _____ (If depth is unknown assume it to be 1.5 times the depth of the pit.)
 - Height of Water Level Above Impermeable Stratum, ft, H _____ (H = D_{stratum} - D_{water})
 - Length of Time Interval, T, in minutes _____
3. At the interval chosen, record the following data in the table below:
 - Time of Measurement, t_n, minutes _____
 - Depth of Water Level Below Reference Level, d_n, inches _____
 - Water Surface Dimensions, ft, l,w _____
4. Calculate the following values and enter in the table below:
 - Water Surface Area, ft², A_n _____
 - Water level Rise m_{rise} (Subtract current value of d_n from previous value)

- Ave. Water Surface Area, ft², A_{av} (Take average of A_n and previous A_n)
- Ave. Height of Water Level Above Impermeable Stratum, ft, h (Take avg. of d_n and previous value of d_n, convert to ft., and subtract from D_{stratum})
- Permeability, in/hr, K_a (Calculate using formula): $K_a = \left[\frac{h_{rise}/T}{2.27 (H^2 - h^2)} \right] \times 60 \text{ min/hr}$

t _n	d _n (in.)	l,w (ft.)	A _n (ft ²)	h _{rise} (in.)	A _{av} (ft ²)	h (ft)	K _a
t ₀	_____	_____	_____	XXXX	XXXX	XXXX	XXXX
t ₁	_____	_____	_____	_____	_____	_____	_____
t ₂	_____	_____	_____	_____	_____	_____	_____
t ₃	_____	_____	_____	_____	_____	_____	_____
t ₄	_____	_____	_____	_____	_____	_____	_____
t ₀	_____	_____	_____	XXXX	XXXX	XXXX	XXXX
t ₁	_____	_____	_____	_____	_____	_____	_____
t ₂	_____	_____	_____	_____	_____	_____	_____
t ₃	_____	_____	_____	_____	_____	_____	_____
t ₄	_____	_____	_____	_____	_____	_____	_____

5. Record the Following Data:
 - Final Depth of Pit, D_{pit}, ft _____
 - Depth to Impermeable Stratum, ft, D_{stratum} _____ (If no impermeable stratum is encountered assume D_{stratum} = D_{pit})
 - Height of Standpipe Above Reference Level, ft, h_{pipe} _____
 - Depth to Water Level after 24 hr. Stabilization Period, ft, D_{water} _____ (Take measurement from top of standpipe. Subtract h_{pipe})
 - Height of Static Water Level Above Impermeable Stratum, ft, H _____ (H = D_{stratum} - D_{water})
 - Average Height of Water Level Above Impermeable Stratum, ft, h _____ (Take average of d_n from beginning and end of last time interval recorded in section 4, convert this to ft., subtract from D_{stratum})

6. Re-calculation of K using data from section 5 above and from final time interval of section 4:

$$K = \left[\frac{h_{rise}/t}{2.27 (H^2 - h^2)} \right] \times 60 \text{ min/hr} = \left[\frac{\quad}{\quad} \right] \times \left[\frac{\quad}{2.27} \right] (\quad - \quad) \times 60 \text{ min/hr} = \quad$$

7. I hereby certify that the information furnished on Form 3f of this application is true and accurate. I am aware that falsification of data is a violation of the Water Pollution Control Act (N.J.S.A. 58:10A-1 et seq.) and is subject to penalties as prescribed in N.J.A.C. 7:14-8.

Signature of Site Evaluator _____ Date _____

Signature of Professional Engineer _____ License # _____

Form 3g. Basin Flooding Test Data

1. Test Number _____ Reference Soil Log _____ Date Tested _____
2. Depth of Pit, ft _____
3. Area of Pit, ft² _____
4. Description of Rock Substratum Within Test Zone:
 - Type of Rock _____
 - Name of Formation _____
 - Average Fracture Spacing _____
 - Type of Fractures (Check Appropriate Category):
 - _____ Open (Wide), Clean—Width of Openings, mm _____
 - _____ Open (Wide), Infilled with Fines—Width of Openings, mm _____
 - _____ Tight (Closed)
 - Orientation of Fractures:
 - _____ Horizontal (Parallel to Pit Bottom) Or Nearly So
 - _____ Inclined
 - _____ Vertical (Parallel to Sides of Pit) Or Nearly So
 - Hardness of Rock:
 - _____ Rippable with Hand Tools
 - _____ Not Rippable with Hand Tools, Rippable by Machine
 - _____ Not Rippable by Machine, Explosives Used

5. Time of First Basin Flooding _____

Volume of Water Added, Gal. _____

6. Result of First Basin Flooding:
 - _____ Basin Drained within 24 Hrs.—Indicate Time _____
 - _____ Basin Not Drained within 24 Hrs.

7. Time of Second Basin Flooding _____

Volume of Water Added, Gal. _____

8. Result of Second Basin Flooding:
 - _____ Basin Drained within 24 Hrs.—Indicate Time _____
 - _____ Basin Not Drained within 24 Hrs.

9. I hereby certify that the information furnished on Form 3g of this application is true and accurate. I am aware that falsification of data is a violation of the Water Pollution Control Act (N.J.S.A. 58:10A-1 et seq.) and is subject to penalties as prescribed in N.J.A.C. 7:14-8.

Signature of Site Evaluator _____ Date _____

Signature of Professional Engineer _____ License # _____

Form 4. General Design Data

1. Volume of Sanitary Sewage, gal. _____
 - _____ Residential: No. of Dwelling Units _____ Total No. of Bedrooms _____

- ___ Commercial/Institutional—Indicate type of establishment and show method of calculation. If estimate is based on water meter data, indicate source of data, frequency of readings, average daily flow, and maximum recorded daily reading ___
- 2. Alterations or Repairs
 - a) Reason for Alteration or Repair (Check appropriate categories):
 - ___ Expansion or Change in Use ___ Upgrade Existing Facilities
 - ___ Correct Malfunctioning System ___ Other—Specify ___
 - b) Describe Nature of Alteration or Repairs: ___
- 3. System Components:
 - a) Grease Trap Capacity, gals ___
Show Calculation Used: ___
 - b) Septic Tank Capacities, gals: ___ First (Single) Compartment ___
___ Second Compartment ___ ___ Third Compartment ___
 - c) Effluent Distribution
Method: ___ Gravity Flow ___ Gravity Dosing
___ Pressure Dosing
Dosing Device: ___ Pump ___ Siphon
 - d) Dosing Tank Capacities, gals: Total Capacity ___ Dose Volume ___
Reserve Capacity ___
 - e) Laterals: Number ___ Total Length ___ Pipe Size ___ Spacing ___
 - f) Connecting Pipe: Size ___ Length ___
 - g) Manifold: Size ___ Length ___
 - h) Disposal Field: Type of Installation ___
Design Permeability (Percolation Rate) ___
Trenches: Width ___ Total Length ___ Bed: Area ___
 - i) Seepage Pits: Design Percolation Rate ___
Number of Pits ___ Total Percolating Area Provided ___
- 4. Attachments (Check items included):
 - ___ General Plan of System Showing Location of All System Components
 - ___ X-Sections of Each System Component Including Grease Trap, Septic Tank, Dosing Tank, Disposal Field, Seepage Pits and Interceptor Drains
 - ___ Pump Performance Curve
 - ___ Other—Specify ___
- 5. I hereby certify that the information furnished on Form 4 of this application (and attachments thereto) is true and accurate. I am aware that falsification of data is a violation of the Water Pollution Control Act (N.J.S.A. 58:10A-1 et seq.) and is subject to penalties as prescribed in N.J.A.C. 7:14-8.

Signature of Professional Engineer _____ Date _____

Form 5. Design of Pressure Dosing System

- 1. Configuration of Distribution Network:
 - Type of Manifold: ___ End ___ Central
 - Distribution Laterals: Number ___ Length, ft ___ Spacing, ft ___
 - Hole Diameter, ins ___ Hole Spacing, ins ___
 - Diameter of Laterals, ins ___
- 2. Lateral Discharge Rate:
 - Design Pressure Head at Supply End of Laterals, H_p , ft ___
 - Hole Discharge Rate, Q , gpm ___
 - Number of Holes per Lateral, n ___
 - Lateral Discharge Rate, $(Q \times n)$ gpm ___
- 3. Manifold Length, ft ___ Manifold Diameter, ins ___
- 4. System Discharge Rate, gpm ___
- 5a. Pump Selection:
 - Diameter of Delivery Pipe ___ Length of Delivery Pipe ___
 - Friction Loss in Delivery Pipe, H_f , ft ___
 - Elevation of Dosing Tank Low Water Level ___
 - Elevation of Lateral Invert ___
 - Elevation Head, H_e , ft ___
 - Total Operating Head, H_t ($H_p + H_f + H_e$), ft ___
 - Pump Model ___ Rated Horsepower ___
 - Pump Discharge Rate at Total Operating Head, gpm ___
- 5b. Siphon Elevation:
 - Diameter of Delivery Pipe ___ Length of Delivery Pipe ___
 - Friction Loss in Delivery Pipe, H_f , ft ___
 - Velocity Head, H_v , ft ___
 - Total Operating Head, H_t ($H_p + H_f + H_v$), ft ___
 - Elevation of Lateral Invert ___
 - Elevation of Siphon Invert ___
- 6. Dose Volume:
 - Design Volume of Sewage, gal/day ___
 - Design Permeability, in/hr ___ or Percolation Rate, min/in ___
 - Internal Volume of Distribution Network ___
 - Dose Volume ___
- 7. I hereby certify that the information furnished on Form 4 of this application (and attachments thereto) is true and accurate. I am aware that falsification of data is a violation of the Water Pollution Control Act (N.J.S.A. 58:10A-1 et seq.) and is subject to penalties as prescribed in N.J.A.C. 7:14-8.

Signature of Professional Engineer _____ Date _____

STANDARD FORMS FOR

CERTIFICATE OF COMPLIANCE

County/Municipality of _____

INSTRUCTIONS: Part A is to be completely filled in for all Certifications. Only Part B or Part C will be completed. Part B will be completed if the administrative authority relies upon the certification signed and sealed by a New Jersey licensed professional engineer that the system has been located, constructed, installed or altered in compliance with the requirements of N.J.A.C. 7:9A-1 and the Application to Construct/Alter/Repair an Individual Subsurface Sewage Disposal System which was approved by the administrative authority. Part C will be completed if the administrative authority performs the certification.

Part A—General Information

- 1. Permitted Activities (Check applicable categories):
 - Permit Number _____
 - ___ New Construction
 - ___ Alteration/No Expansion or Change of Use
 - ___ Alteration/Expansion or Change in Use
 - ___ Alteration/Malfunctioning System
 - ___ Deviation from Standards
 - ___ Repairs to Existing System
- 2. Location of Project:
 - Municipality _____ Lot _____ Block _____
 - Street Address _____
- 3. Name and Present Address of Applicant:
 - Applicant's Phone Number _____

Part B—Professional Engineers Certification

I certify under penalty of law that the subsurface sewage disposal system identified in Part A has been located, constructed, installed or altered in compliance with the requirements of N.J.A.C. 7:9A-1 and the Application to Construct/Alter/Repair an Individual Subsurface Sewage Disposal System which was approved by the administrative authority. I am aware that there are significant penalties for submitting false information, including the possibility of fine and imprisonment.

(Signature)

SEAL

Name (Type or Print), License #

Date: _____

Part C—Certification by Administrative Authority

I certify under penalty of law that the subsurface sewage disposal system identified in Part A has been located, constructed, installed or altered in compliance with the requirements of N.J.A.C. 7:9A-1 and the Application to Construct/Alter/Repair an Individual Subsurface Sewage Disposal System which was approved by the administrative authority. I am aware that there are significant penalties for submitting false information, including the possibility of fine and imprisonment.

Authorized Signature

Type of License Held

Name (Typed or Printed)

License Number

Date: _____

For Agency Use Only

Date Received: _____
Form Determined To Be: ___ Complete ___ Incomplete
Date Returned _____
Date Received _____

Date Certification Approved: _____
Authorized Signature: _____

Amended by R.1993 d.294, effective June 21, 1993.
See: 24 N.J.R. 1987(a), 25 N.J.R. 2704(b).

APPENDIX C

UNIFORM PLACEMENT OF PERCOLATION TESTS

Uniform Placement of Percolation Tests